



# Stainless Steel Air Cylinders

Series SA

aerospace  
climate control  
electromechanical  
filtration  
fluid & gas handling  
hydraulics  
**pneumatics**  
process control  
sealing & shielding



ENGINEERING YOUR SUCCESS.

In line with our policy of continuing product improvement, specifications and information contained in this catalog are subject to change.

Copyright ©2010 by Parker Hannifin Corporation.  
All rights reserved.

PRINTED IN THE U.S.A.

 **Warning**

FAILURE OR IMPROPER SELECTION OR IMPROPER USE OF THE PRODUCTS AND/OR SYSTEMS DESCRIBED HEREIN OR RELATED ITEMS CAN CAUSE DEATH, PERSONAL INJURY AND PROPERTY DAMAGE.

This document and other information from Parker Hannifin Corporation, its subsidiaries and authorized distributors provide product and/or system options for further investigation by users having technical expertise. It is important that you analyze all aspects of your application, including consequences of any failure and review the information concerning the product or system in the current product catalog. Due to the variety of operating conditions and applications for these products or systems, the user, through its own analysis and testing, is solely responsible for making the final selection of the products and systems and assuring that all performance, safety and warning requirements of the application are met.

The product described herein, including without limitation, product features, specifications, designs, availability and pricing, are subject to change by Parker Hannifin Corporation and its subsidiaries at any time without notice.

**Offer of Sale**

The items described in this document are hereby offered for sale by Parker Hannifin Corporation, its subsidiaries or its authorized distributors. This offer and its acceptance are governed by provisions stated on a separate page of the document entitled 'Offer of Sale'.

**Table of Contents**

<b>Table of Contents</b>	<b>Page No.</b>
Cylinder Weights .....	3
Breakaway Pressure .....	3
Cylinder Force and Volume Charts .....	3
Design Features and Materials .....	4
Standard Specification .....	5
Mounting Style Index .....	5
Dimensions:        1 1/2" - 8" Bore .....	6-10
1 1/8" Bore .....	13-17
Double Rod Models: 1 1/2" - 8" Bore .....	11
1 1/8" Bore .....	16
Accessories:        1 1/2" - 8" Bore .....	12
1 1/8" Bore .....	18
Piston Rod Selection .....	19
Switches .....	20-21
How-to-Order .....	22-23
Optional Piston Bumper Seals .....	23
Cylinder Safety Guide .....	26-27
Offer of Sale .....	29

## Cylinders for your unique need –

The Atlas Series SA stainless steel cylinder combines corrosion resistance with proven reliability. It is specifically designed to meet today's demand for cylinders in harsh chemical washdown environments.

Series SA premium quality air cylinders have many different options to meet your every need. With eight mounting styles, optional cushions, piston bumper seals, or magnetic piston, you can order exactly what you need. The Series SA cylinder is rated for Non-Lube service to keep the cylinder as low maintenance as possible. It is made completely of 303 and 304 stainless steel material with the exception of the aluminum piston, which resists many corrosive elements. This cylinder is also popular in the food processing industry when cleanliness and a bacteria free environment is of most importance.

Series SA non-lube premium quality air cylinders are available for quick delivery to minimize your downtime. The SA cylinder should be your next choice when specifying stainless steel cylinders.

Parker Cylinder Division and over 130 distributors provide the local personalized service customers demand. The Parker team ensures the right solution and product is in place to meet customer needs.

For further information on our cylinder products and capabilities, contact your local Atlas Cylinders distributor or visit us on the web at [www.atlascylinders.com](http://www.atlascylinders.com).



Cylinder Weights In pounds (kilograms)

Bore	Rod	Mounting Code				Add Per Inch of Stroke
		T, F, C, JB, HB, & TE	J & H	'BB & BE	D & DB	
1 1/8" (28.58)	3/8" (9.53)	1.1 (.49)	1.5 (.68)	1.3 (.58)	- -	.13 (.05)
	1/2" (12.70)	1.2 (.54)	1.6 (.72)	1.4 (.63)	- -	.15 (.06)
1 1/2" (38.10)	5/8" (15.88)	3.3 (1.49)	4.0 (1.81)	3.8 (1.72)	3.8 (1.72)	.3 (.13)
	1" (25.40)	4.1 (1.85)	4.8 (2.17)	4.6 (2.08)	4.6 (2.08)	.4 (.18)
2" (50.80)	5/8" (15.88)	5.9 (2.67)	7.0 (3.17)	6.4 (2.90)	6.4 (2.90)	.5 (.22)
	1" (25.40)	6.3 (2.85)	7.4 (3.35)	6.8 (2.94)	6.8 (3.08)	.6 (.27)
2 1/2" (63.50)	5/8" (15.88)	8.0 (3.62)	9.5 (4.30)	8.7 (3.94)	8.5 (3.85)	.6 (.27)
	1" (25.40)	8.5 (3.85)	10.0 (4.53)	9.2 (4.17)	9.0 (4.08)	.7 (.31)
3 1/4" (82.55)	1" (25.40)	15.0 (6.80)	18.7 (8.48)	16.0 (7.25)	15.5 (7.03)	.8 (.36)
	1 3/8" (34.93)	15.5 (7.03)	19.2 (8.70)	16.5 (7.48)	16.0 (7.25)	1.0 (.45)
4" (101.60)	1" (25.40)	23.0 (10.43)	28.0 (12.70)	27.0 (12.24)	23.5 (10.65)	1.0 (.45)
	1 3/8" (34.93)	23.5 (10.65)	28.5 (12.92)	27.5 (12.47)	24.0 (10.88)	1.2 (.54)
5" (127.00)	1" (25.40)	34.5 (15.64)	42.0 (19.05)	41.0 (18.59)	35.0 (15.87)	1.1 (.49)
	1 3/8" (34.93)	35.0 (15.87)	42.5 (19.27)	41.5 (18.82)	35.5 (16.10)	1.3 (.58)
6" (152.40)	1 3/8" (34.93)	60.0 (27.21)	71.9 (32.61)	69.0 (31.29)	61.2 (27.76)	1.5 (.68)
	1 3/4" (44.45)	62.0 (28.12)	73.9 (33.52)	71.0 (32.20)	63.2 (28.66)	1.7 (.77)
8" (203.20)	1 3/8" (34.93)	79.0 (35.83)	- -	88.0 (39.91)	80.2 (36.37)	2.0 (.90)
	1 3/4" (44.45)	82.0 (37.19)	- -	91.0 (41.27)	83.2 (37.73)	2.3 (1.04)

<sup>1</sup> Weight includes pivot pin

Breakaway Pressure In PSI

Bore	SA Series	
	Extend	Retract
1 1/8"	6	7
1 1/2", 2", 2 1/2"	5	6
3 1/4", 4"	4	5
5", 6", 8"	3	4

Listed are the average breakaway pressures in PSI for all Series SA cylinder bore sizes.

Note: Breakaway pressures were established with the cylinders mounted horizontally and no load on the piston rod.

Cylinder Force and Volume Charts Extended Forces in pounds (newtons)

Bore	Piston Area in <sup>2</sup> (cm <sup>2</sup> )	PSI (bar)						Volume Cu Ft (cm <sup>3</sup> ) Displacement Per Inch
		40 (3)	60 (4)	80 (6)	100 (7)	150 (10)	200 (14)	
1 1/8"	.99 (6.41)	40 (177)	60 (265)	80 (354)	99 (442)	149 (664)	200 (890)	.00057 (16)
1 1/2"	1.77 (11.40)	71 (315)	106 (472)	142 (629)	177 (786)	266 (1179)	353 (1570)	.00102 (29)
2"	3.14 (20.27)	126 (559)	189 (839)	251 (1119)	314 (1398)	471 (2097)	628 (2793)	.00182 (52)
2 1/2"	4.91 (31.67)	196 (874)	295 (1311)	393 (1748)	491 (2185)	737 (3277)	982 (4368)	.00284 (80)
3 1/4"	8.30 (53.32)	332 (1477)	498 (2215)	664 (2953)	830 (3692)	1245 (5538)	1659 (7379)	.00480 (136)
4"	12.57 (81.07)	503 (2237)	754 (3355)	1005 (4473)	1257 (5592)	1886 (8388)	2513 (11178)	.00727 (206)
5"	19.64 (126.71)	785 (3491)	1178 (5240)	1571 (6988)	1964 (8736)	2946 (13104)	3928 (17472)	.01137 (322)
6"	28.27 (182.39)	1130 (5026)	1696 (7544)	2262 (10061)	2827 (12574)	4240 (18860)	5654 (25149)	.01837 (520)
8"	50.26 (324.26)	2010 (8940)	3015 (13411)	4020 (17881)	5026 (22356)	7539 (33533)	10052 (44711)	.02227 (631)

Deduct these Forces for Retract Strokes in Pounds (newtons)

Rod	Rod Area in <sup>2</sup> (cm <sup>2</sup> )	PSI (bar)						Volume Cu Ft (cm <sup>3</sup> ) Displacement Per Inch
		40 (3)	60 (4)	80 (6)	100 (7)	150 (10)	200 (14)	
3/8"	.112 (.72)	5 (20)	7 (30)	9 (40)	11 (50)	17 (75)	22 (100)	.00007 (2)
1/2"	.196 (1.26)	8 (35)	12 (52)	16 (70)	20 (87)	30 (131)	39 (174)	.00011 (3)
5/8"	.307 (1.98)	12 (53)	18 (80)	25 (111)	31 (138)	46 (205)	61 (271)	.00018 (5)
1"	.785 (5.06)	31 (138)	47 (209)	63 (280)	70 (351)	118 (525)	157 (698)	.00045 (13)
1 3/8"	1.485 (9.58)	59 (262)	89 (396)	119 (529)	149 (663)	222 (997)	297 (1321)	.00086 (24)
1 3/4"	2.404 (15.51)	95 (423)	144 (641)	192 (854)	240 (1068)	360 (1601)	480 (2135)	.00139 (39)

## Features

**1 Piston Seals:** Nitrile lipseals are pressure energized and wear compensating. Their excellent lubrication retention characteristics lower seal friction and ensure long life.

**2 Piston:** Solid aluminum alloy, light-weight for low inertia, yet strong.

**3 Head/Cap:** Precision machined from solid corrosion-resistant 304 stainless steel bar.

**4 Rod Wiper:** Urethane lipseals aggressively wipe foreign material from piston rod and enhance rod seal life.

**5 Rod Seals:** Rounded urethane lipseals are pressure energized and wear compensating.

**6 Piston Rod:** 303 stainless steel, 40,000 PSI minimum yield, hard chrome plated, ground and polished.

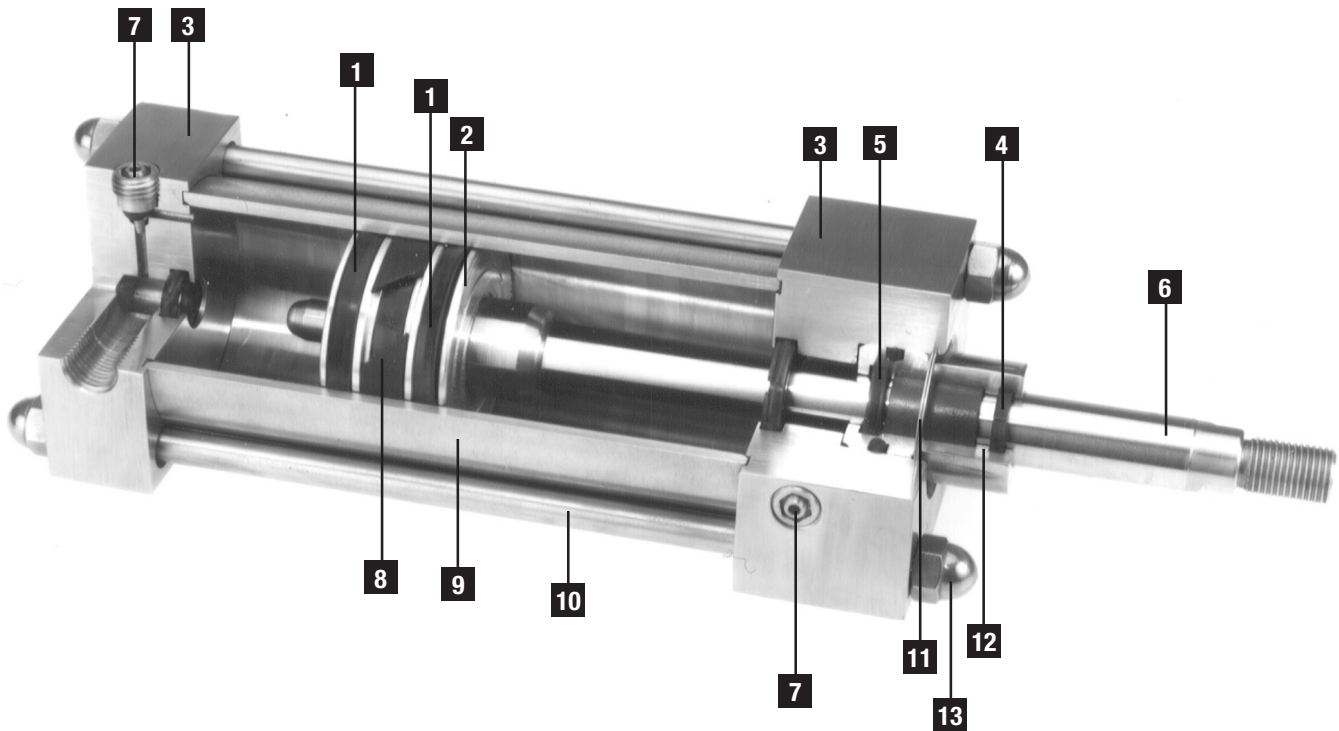

**7 Adjustable Captive Cushion Needle:** Allows for safe and precise adjustment under pressure.

**8 Wear Strip:** PTFE and graphite composition for minimum friction, maximum wear and side load resistance. (Magnetic band under wear strip optional.)

**9 Tube:** Corrosion-resistant 304 stainless steel.

**10 Tie Rods:** High-strength 303 stainless steel maintains compression on tube end seals.

**11 Retainer:** Stainless steel snap ring securely retains bushing in head.

**12 Rod Bearings:** Machined from 304 stainless steel, with a PTFE composite wear band insert that eliminates metal-to-metal contact.

**13 Acorn Nut:** Tie rod threads are covered by stainless steel acorn nuts which eliminates a bacteria hiding place.

**Operating Temperatures:**

Standard Seals                    -40°F to 200°F  
     (-40°C to 93°C)  
 Fluorocarbon Seals         -20°F to 400°F  
     (-29°C to 204°C)

**Operating Pressure:**

250 PSIG Air (17.2 Bar)  
 Bore Sizes: 1-1/8", 1-1/2", 2", 2-1/2", 3-1/4",  
 4", 5", 6", 8"

**Supply:**

Filtered compressed air to 250 PSI  
 Petroleum based hydraulic fluid to 400 PSI,  
 1-1/2"-8" bore only

**Lubrication:**

None required  
 Series SA Cylinders are rated for "no lube added" service. All internal components are lubricated at time of assembly with a PTFE based grease.

**Materials:**

Head and End Caps: 304 stainless steel  
 Tube: 304 stainless steel  
 Piston Rod: hard chrome plated 303 stainless steel  
 Piston: 2011-T451 aluminum with PTFE composite wearband  
 Rod Bearings: 304 stainless steel with PTFE composite wearband  
 Seals: urethane rod seal and wiper, nitrile piston seals  
 Tie Rods: 303 stainless steel

**Available Mounting Styles 1 1/2" to 8" Bores**

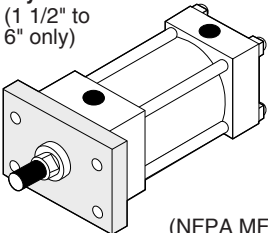
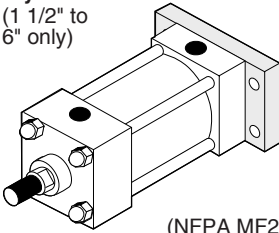
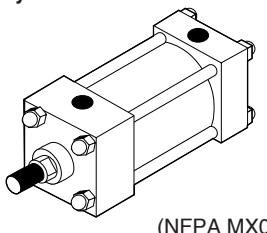
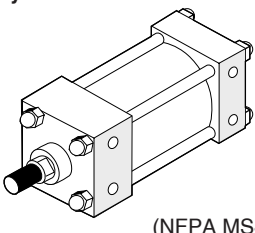
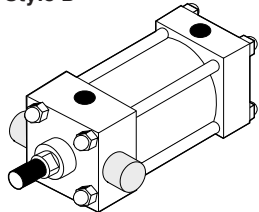
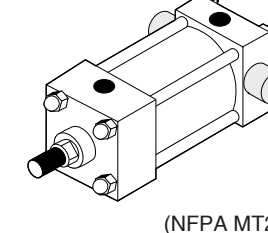
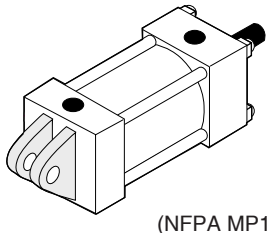
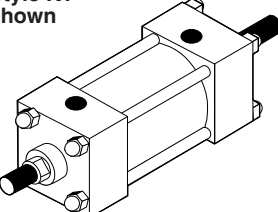
<p>Head Rectangular Flange</p> <p><b>Style J</b> (1 1/2" to 6" only)</p>  <p>(NFPA MF1)</p>	<p>Cap Rectangular Flange</p> <p><b>Style H</b> (1 1/2" to 6" only)</p>  <p>(NFPA MF2)</p>	<p>No Mount (Basic)</p> <p><b>Style T</b></p>  <p>(NFPA MX0)</p>	<p>Side Tap</p> <p><b>Style F</b></p>  <p>(NFPA MS4)</p>
<p>Head Trunnion</p> <p><b>Style D</b></p>  <p>(NFPA MT1)</p>	<p>Cap Trunnion</p> <p><b>Style DB</b></p>  <p>(NFPA MT2)</p>	<p>Cap Fixed Clevis</p> <p><b>Style BB</b></p>  <p>(NFPA MP1)</p>	<p>Double Rod End</p> <p><b>Style KT shown</b></p> 

**No Mount Basic (1 1/2" to 8" Bores)**

Style T  
(NFPA MX0)

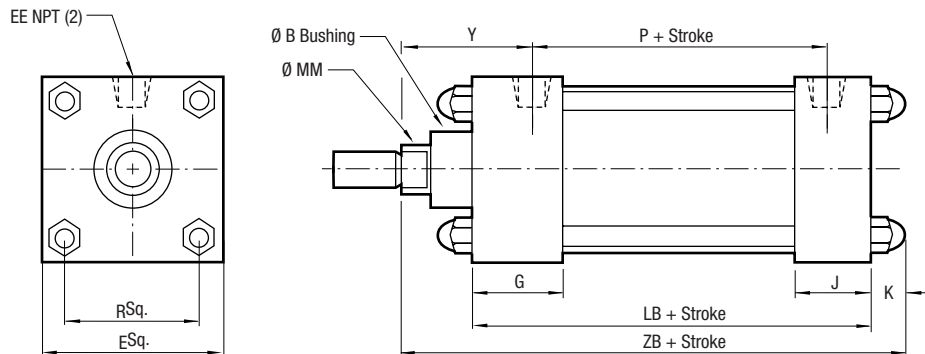

**Head Rectangular Flange (1 1/2" to 6" Bores)**

Style J  
(NFPA MF1)

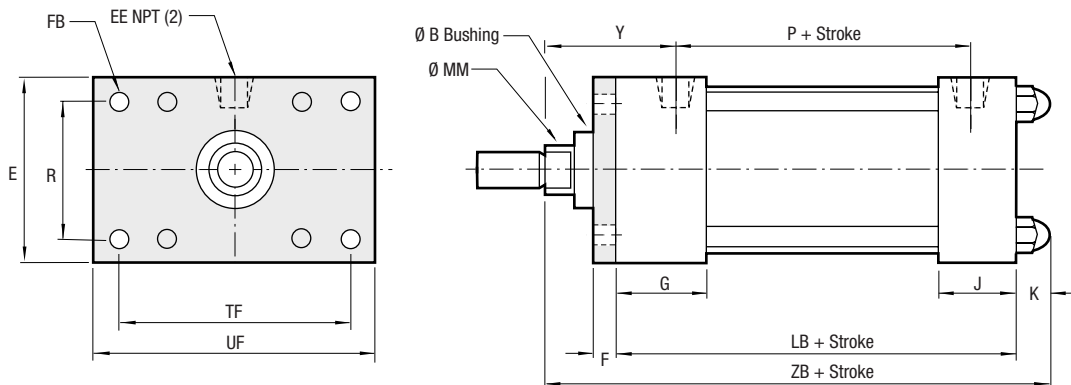

**Cap Rectangular Flange (1 1/2" to 6" Bores)**

Style H  
(NFPA MF2)

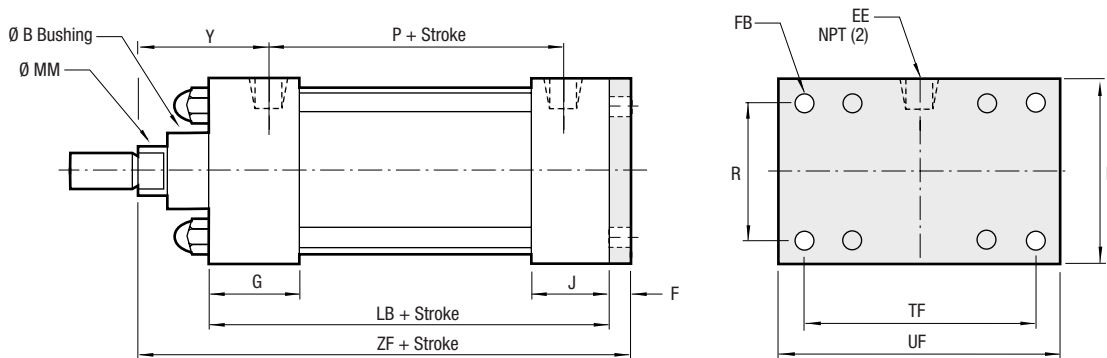



Rod End Dimensions – Basic Cylinder

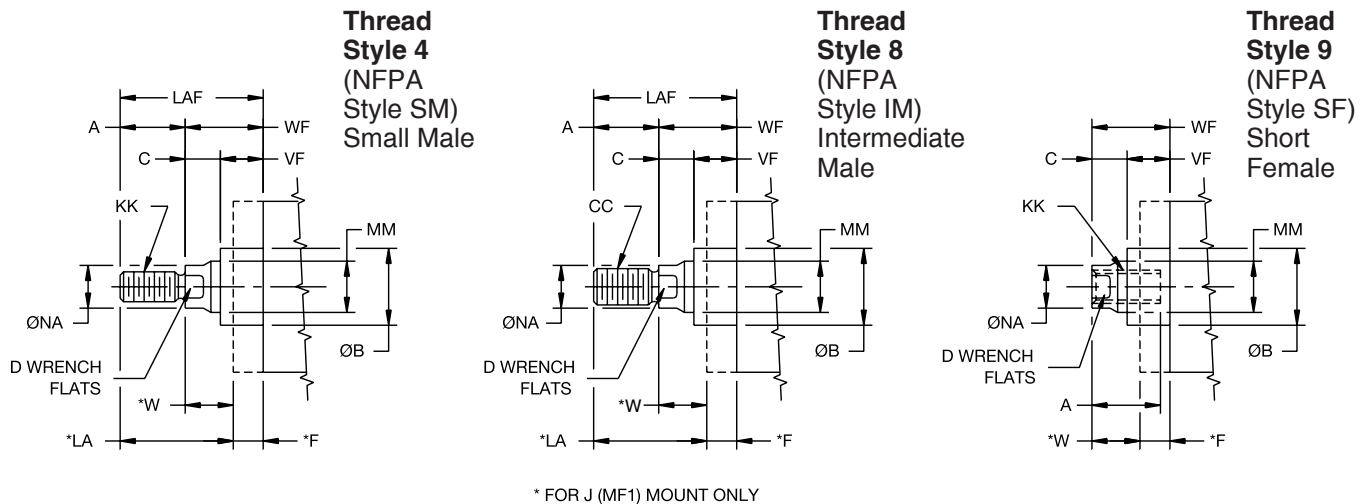

“Special Thread” Style 3

To order specify “Style 3” and give desired dimensions for CC or KK, A and W or WF. If otherwise special, furnish dimensioned sketch.

Table 1 – Envelope & Mounting Dimensions

Bore Size	E	EE	F	FB	G	J	K	R	TF	UF	Add Stroke	
											LB	P
1 1/2	2	3/8 <sup>1</sup>	3/8	5/16	1 1/2	1	15/32	1.43	2 3/4	3 3/8	3 5/8	2 1/8
2	2 1/2	3/8	3/8	3/8	1 1/2	1	17/32	1.84	3 3/8	4 1/8	3 5/8	2 1/8
2 1/2	3	3/8	3/8	3/8	1 1/2	1	17/32	2.19	3 7/8	4 5/8	3 3/4	2 1/4
3 1/4	3 3/4	1/2	5/8	7/16	1 3/4	1 1/4	5/8	2.76	4 11/16	5 1/2	4 1/4	2 5/8
4	4 1/2	1/2	5/8	7/16	1 3/4	1 1/4	5/8	3.32	5 7/16	6 1/4	4 1/4	2 5/8
5	5 1/2	1/2	5/8	9/16	1 3/4	1 1/2	27/32	4.10	6 5/8	7 5/8	4 1/2	2 7/8
6	6 1/2	3/4	3/4	9/16	2	1 1/2	27/32	4.88	7 5/8	8 5/8	5	3
8	8 1/2	3/4	-	-	2	1 1/2	1	6.44	-	-	5 1/8	3 1/8

<sup>1</sup> On 1 1/2" bore with code 2 rod head end port is 1/4" NPT.

Table 3 – Envelope and Mounting Dimensions

Table 2 – Rod Dimensions

Bore Size	Rod No.	Rod		Thread		A	B	C	D	LA	LAF	VF	W	WF	Y	Add Stroke	
		Dia. MM	Style 8 CC	Style 4,9 KK	ZB											ZF	
1 1/2	1	5/8	1/2-20	7/16-20	3/4	1.125	3/8	1/2	1 3/8	1 3/4	5/8	5/8	1	2	5 3/32	5	
	2	1	7/8-14	3/4-16	1 1/8	1.500	1/2	13/16	2 1/8	2 1/2	7/8	1	1 3/8	2 3/8	5 15/32	5 3/8	
2	1	5/8	1/2-20	7/16-20	3/4	1.125	3/8	1/2	1 3/8	1 3/4	5/8	5/8	1	2	5 5/32	5	
	3	1	7/8-14	3/4-16	1 1/8	1.500	1/2	13/16	2 1/8	2 1/2	7/8	1	1 3/8	2 3/8	5 17/32	5 3/8	
2 1/2	1	5/8	1/2-20	7/16-20	3/4	1.125	3/8	1/2	1 3/8	1 3/4	5/8	5/8	1	2	5 9/32	5 1/8	
	3	1	7/8-14	3/4-16	1 1/8	1.500	1/2	13/16	2 1/8	2 1/2	7/8	1	1 3/8	2 3/8	5 21/32	5 1/2	
3 1/4	1	1	7/8-14	3/4-16	1 1/8	1.500	1/2	13/16	1 7/8	2 1/2	7/8	3/4	1 3/8	2 7/16	6 1/4	6 1/4	
	3	1 3/8	1 1/4-12	1-14	1 5/8	2.000	5/8	1 1/8	2 5/8	3 1/4	1	1	1 5/8	2 11/16	6 1/2	6 1/2	
4	1	1	7/8-14	3/4-16	1 1/8	1.500	1/2	13/16	1 7/8	2 1/2	7/8	3/4	1 3/8	2 7/16	6 1/4	6 1/4	
	3	1 3/8	1 1/4-12	1-14	1 5/8	2.000	5/8	1 1/8	2 5/8	3 1/4	1	1	1 5/8	2 11/16	6 1/2	6 1/2	
5	1	1	7/8-14	3/4-16	1 1/8	1.500	1/2	13/16	1 7/8	2 1/2	7/8	3/4	1 3/8	2 7/16	6 23/32	6 1/2	
	3	1 3/8	1 1/4-12	1-14	1 5/8	2.000	5/8	1 1/8	2 5/8	3 1/4	1	1	1 5/8	2 11/16	6 31/32	6 3/4	
6	1	1 3/8	1 1/4-12	1-14	1 5/8	2.000	5/8	1 1/8	2 1/2	3 1/4	1	7/8	1 5/8	2 7/8	7 15/32	7 3/8	
	3	1 3/4	1 1/2-12	1 1/4-12	2	2.375	3/4	1 1/2	3 1/8	3 7/8	1 1/8	1 1/8	1 7/8	3 1/8	7 23/32	7 5/8	
8	1	1 3/8	1 1/4-12	1-14	1 5/8	2.000	5/8	1 1/8	-	3 1/4	1	-	1 5/8	2 7/8	7 3/4	-	
	3	1 3/4	1 1/2-12	1 1/4-12	2	2.375	3/4	1 1/2	-	3 7/8	1 1/8	-	1 7/8	3 1/8	8	-	

**Side Tap Mount  
Style F  
(NFPA MS4)**

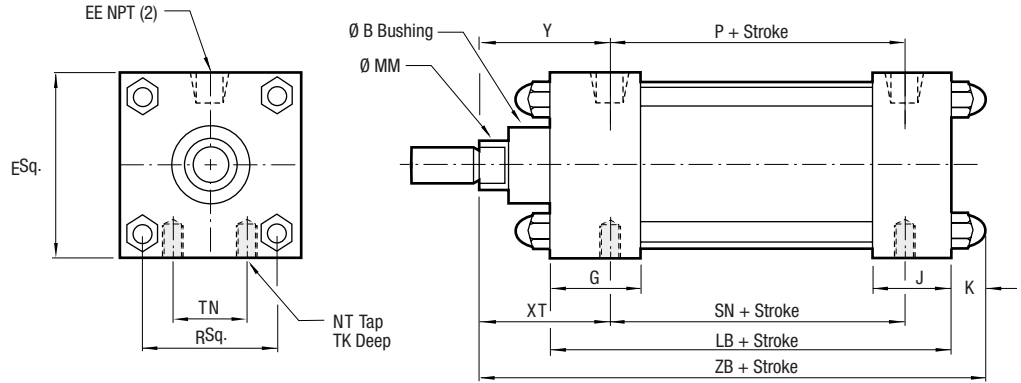

**Cap Fixed  
Clevis Mount  
Style BB  
(NFPA MP1)**

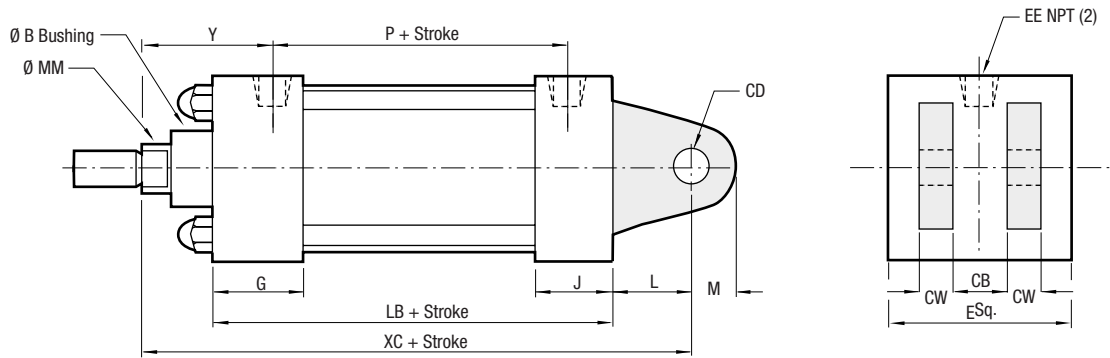

**Head Trunnion Mount  
Style D  
(NFPA MT1)**

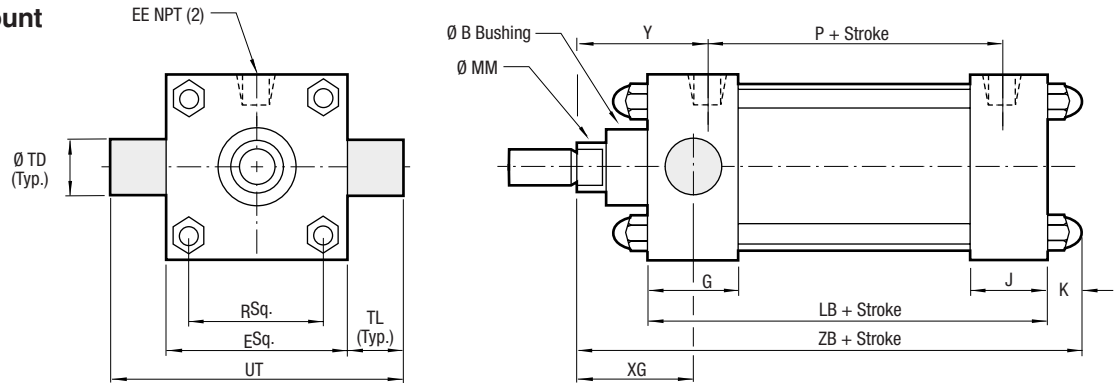

**Cap Trunnion Mount  
Style DB  
(NFPA MT2)**

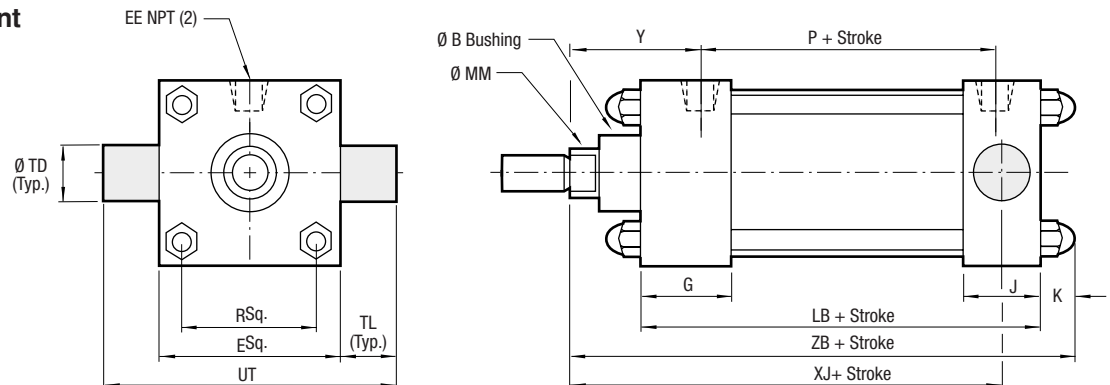

Rod End Dimensions – Basic Cylinder

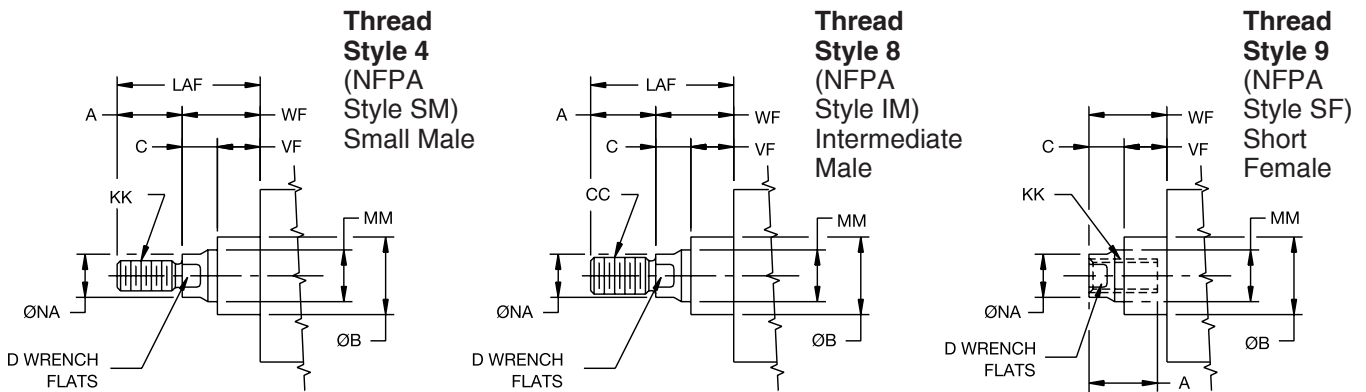

“Special Thread” Style 3

To order specify “Style 3” and give desired dimensions for CC or KK, A and W or WF. If otherwise special, furnish dimensioned sketch.

Table 1 – Envelope & Mounting Dimensions

Bore Size	CB	CD	CW	E	EE	G	J	K	L	M	NT	R	TD	TK	TL	TN	UT	Add Stroke		
																		LB	P	SN
1 1/2	3/4	0.500	1/2	2	3/8 <sup>1</sup>	1 1/2	1	15/32	3/4	5/8	1/4-20	1.43	1.000	3/8	1	5/8	4	3 5/8	2 1/8	2 1/4
2	3/4	0.500	1/2	2 1/2	3/8	1 1/2	1	17/32	3/4	5/8	5/16-18	1.84	1.000	1/2	1	7/8	4 1/2	3 5/8	2 1/8	2 1/4
2 1/2	3/4	0.500	1/2	3	3/8	1 1/2	1	17/32	3/4	5/8	3/8-16	2.19	1.000	5/8	1	1 1/4	5	3 3/4	2 1/4	2 3/8
3 1/4	1 1/4	0.750	5/8	3 3/4	1/2	1 3/4	1 1/4	5/8	1 1/4	7/8	1/2-13	2.76	1.000	3/4	1	1 1/2	5 3/4	4 1/4	2 5/8	2 5/8
4	1 1/4	0.750	5/8	4 1/2	1/2	1 3/4	1 1/4	5/8	1 1/4	7/8	1/2-13	3.32	1.000	3/4	1	2 1/16	6 1/2	4 1/4	2 5/8	2 5/8
5	1 1/4	0.750	5/8	5 1/2	1/2	1 3/4	1 1/2	27/32	1 1/4	7/8	5/8-11	4.10	1.000	1	1	2 11/16	7 1/2	4 1/2	2 7/8	2 7/8
6	1 1/2	1.000	3/4	6 1/2	3/4	2	1 1/2	27/32	1 1/2	1	3/4-10	4.88	1.375	1 1/8	1 3/8	3 1/4	9 1/4	5	3	3 1/8
8	1 1/2	1.000	3/4	8 1/2	3/4	2	1 1/2	1	1 1/2	1	3/4-10	6.44	1.375	1 1/8	1 3/8	4 1/2	11 1/4	5 1/8	3 1/8	3 1/4

<sup>1</sup> On 1 1/2" bore with code 2 rod head end port is 1/4" NPT.

Table 2 – Rod Dimensions

Bore Size	Rod No.	Rod		Thread		A	B	C	D	LAF	VF	WF	XG	XT	Y	Add Stroke		
		Dia. MM	Style 8 CC	Style 4, 9 KK	XC											XJ	ZB	
1 1/2	1	5/8	1/2-20	7/16-20	3/4	1.125	3/8	1/2	1 3/4	5/8	1	1 3/4	1 15/16	2	5 3/8	4 1/8	5 3/32	
	2	1	7/8-14	3/4-16	1 1/8	1.500	1/2	13/16	2 1/2	7/8	1 3/8	2 1/8	2 5/16	2 3/8	5 3/4	4 1/2	5 15/32	
2	1	5/8	1/2-20	7/16-20	3/4	1.125	3/8	1/2	1 3/4	5/8	1	1 3/4	1 15/16	2	5 3/8	4 1/8	5 5/32	
	3	1	7/8-14	3/4-16	1 1/8	1.500	1/2	13/16	2 1/2	7/8	1 3/8	2 1/8	2 5/16	2 3/8	5 3/4	4 1/2	5 17/32	
2 1/2	1	5/8	1/2-20	7/16-20	3/4	1.125	3/8	1/2	1 3/4	5/8	1	1 3/4	1 15/16	2	5 1/2	4 1/4	5 9/32	
	3	1	7/8-14	3/4-16	1 1/8	1.500	1/2	13/16	2 1/2	7/8	1 3/8	2 1/8	2 5/16	2 3/8	5 7/8	4 5/8	5 21/32	
3 1/4	1	1	7/8-14	3/4-16	1 1/8	1.500	1/2	13/16	2 1/2	7/8	1 3/8	2 1/4	2 7/16	2 7/16	6 7/8	5	6 1/4	
	3	1 3/8	1 1/4-12	1-14	1 5/8	2.000	5/8	1 1/8	3 1/4	1	1 5/8	2 1/2	2 11/16	2 11/16	7 1/8	5 1/4	6 1/2	
4	1	1	7/8-14	3/4-16	1 1/8	1.500	1/2	13/16	2 1/2	7/8	1 3/8	2 1/4	2 7/16	2 7/16	6 7/8	5	6 1/4	
	3	1 3/8	1 1/4-12	1-14	1 5/8	2.000	5/8	1 1/8	3 1/4	1	1 5/8	2 1/2	2 11/16	2 11/16	7 1/8	5 1/4	6 1/2	
5	1	1	7/8-14	3/4-16	1 1/8	1.500	1/2	13/16	2 1/2	7/8	1 3/8	2 1/4	2 7/16	2 7/16	7 1/8	5 1/4	6 23/32	
	3	1 3/8	1 1/4-12	1-14	1 5/8	2.000	5/8	1 1/8	3 1/4	1	1 5/8	2 1/2	2 11/16	2 11/16	7 3/8	5 1/2	6 31/32	
6	1	1 3/8	1 1/4-12	1-14	1 5/8	2.000	5/8	1 1/8	3 1/4	1	1 5/8	2 5/8	2 13/16	2 7/8	8 1/8	5 7/8	7 15/32	
	3	1 3/4	1 1/2-12	1 1/4-12	2	2.375	3/4	1 1/2	3 7/8	1 1/8	1 7/8	2 7/8	3 1/16	3 1/8	8 3/8	6 1/8	7 23/32	
8	1	1 3/8	1 1/4-12	1-14	1 5/8	2.000	5/8	1 1/8	3 1/4	1	1 5/8	2 5/8	2 13/16	2 7/8	8 1/4	6	7 3/4	
	3	1 3/4	1 1/2-12	1 1/4-12	2	2.375	3/4	1 1/2	3 7/8	1 1/8	1 7/8	2 7/8	3 1/16	3 1/8	8 1/2	6 1/4	8	

Table 3 – Envelope and Mounting Dimensions

**Head Square  
 Style JB  
 (NFPA ME3)  
 8" Bore only**

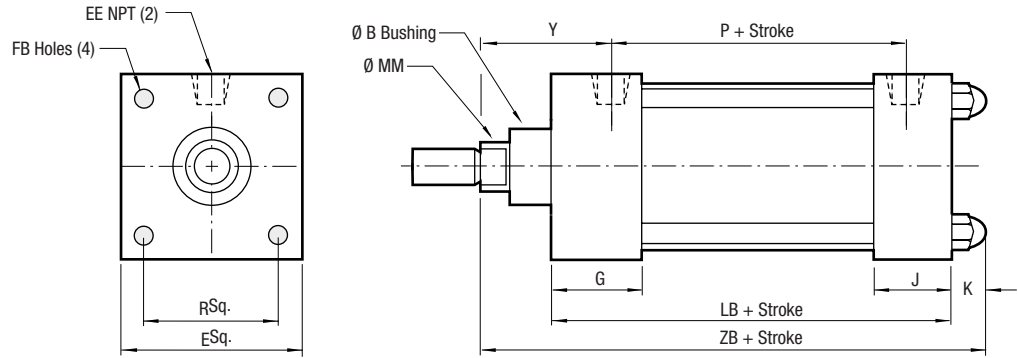

**Cap Square  
 Style HB  
 (NFPA ME4)  
 8" Bore only**

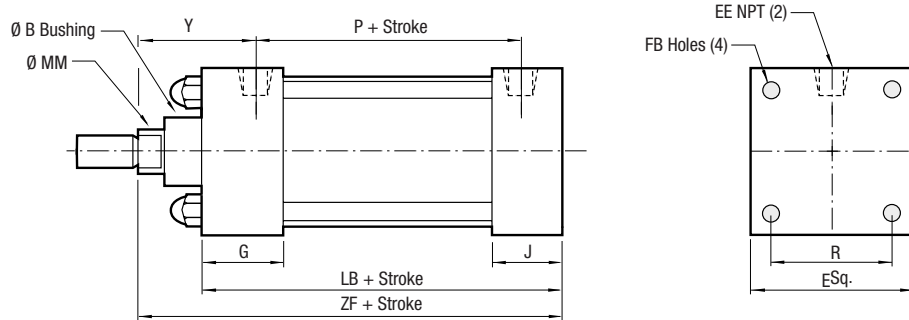

**Standard & Optional Rod Ends**

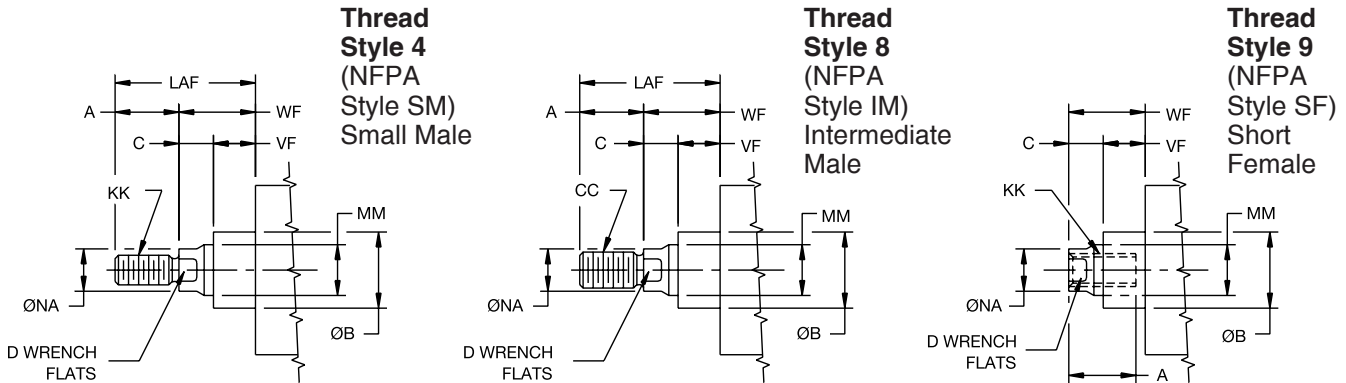

**Table 1 – Envelope & Mounting Dimensions**

	E	EE	FB	G	J	K	R	Add Stroke	
								LB	P
JB (ME3)	8 1/2	3/4	11/16	2	1 1/2	1	7.57	5 1/8	3 1/8
HB (ME4)	8 1/2	3/4	11/16	2	1 1/2	1	7.57	5 1/8	3 1/8

**Table 2 – Rod Dimensions**

	Rod Code	Rod	Thread		A	B	C	D	LAF	VF	WF	Y	Add Stroke	
		Dia.	Style 8 CC	Style 4, 9 KK									ZB	ZF
JB (ME3)	1	1 3/8	1-1/4-12	1-14	1 5/8	2.000	5/8	1 1/8	3 1/4	1	1 5/8	2 7/8	7 3/4	-
	3	1 3/4	1-1/2-12	1-1/4-12	2	2.375	3/4	1 1/2	3 7/8	1 1/8	1 7/8	3 1/8	8	-
HB (ME4)	1	1 3/8	1-1/4-12	1-14	1 5/8	2.000	5/8	1 1/8	3 1/4	1	1 5/8	2 7/8	-	6 3/4
	3	1 3/4	1-1/2-12	1-1/4-12	2	2.375	3/4	1 1/2	3 7/8	1 1/8	1 7/8	3 1/8	-	7

**Table 3 – Envelope and Mounting Dimensions**

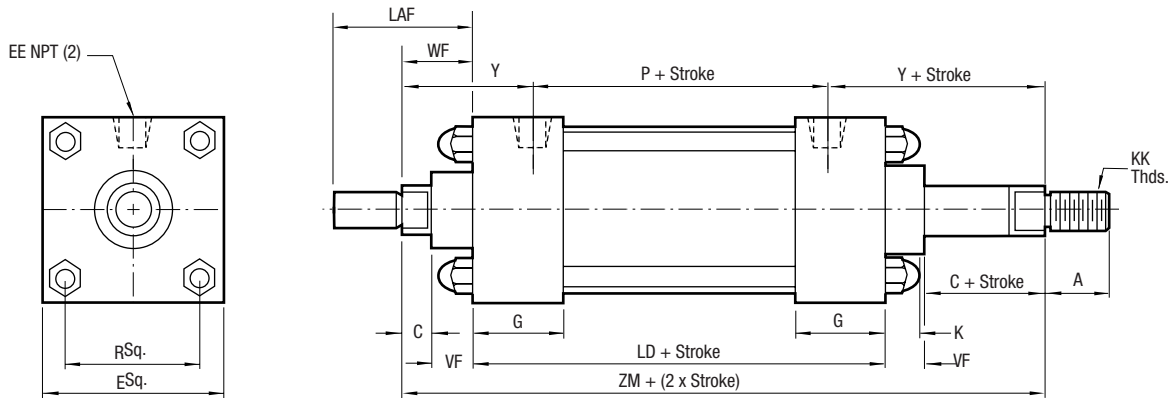

Table 1 – Envelope & Mounting Dimensions

Bore Size	E	EE	G	K	R	Add Stroke	
						LD	P
1 1/2	2	3/8 <sup>1</sup>	1 1/2	15/32	1.43	4 1/8	2 1/8
2	2 1/2	3/8	1 1/2	17/32	1.84	4 1/8	2 1/8
2 1/2	3	3/8	1 1/2	17/32	2.19	4 1/4	2 1/4
3 1/4	3 3/4	1/2	1 3/4	5/8	2.76	4 3/4	2 5/8
4	4 1/2	1/2	1 3/4	5/8	3.32	4 3/4	2 5/8
5	5 1/2	1/2	1 3/4	27/32	4.10	5	2 7/8
6	6 1/2	3/4	2	27/32	4.88	5 1/2	3
8	8 1/2	3/4	2	1	6.44	5 1/2	3 1/8

<sup>1</sup>On 1 1/2" bore with code 2 rod head end port is 1/4" NPT.

Table 2 – Rod Dimensions

Bore Size	Rod No.	Rod Dia. MM	Thread		A	B	C	D	LAF	VF	WF	Y	Add 2x Stroke ZM
			Style 8 CC	Style 4, 9 KK									
1 1/2	1	5/8	1/2-20	7/16-20	3/4	1.125	3/8	1/2	1 3/4	5/8	1	2	6 1/8
	2	1	7/8-14	3/4-16	1 1/8	1.500	1/2	13/16	2 1/2	7/8	1 3/8	2 3/8	6 7/8
2	1	5/8	1/2-20	7/16-20	3/4	1.125	3/8	1/2	1 3/4	5/8	1	2	6 1/8
	3	1	7/8-14	3/4-16	1 1/8	1.500	1/2	13/16	2 1/2	7/8	1 3/8	2 3/8	6 7/8
2 1/2	1	5/8	1/2-20	7/16-20	3/4	1.125	3/8	1/2	1 3/4	5/8	1	2	6 1/4
	3	1	7/8-14	3/4-16	1 1/8	1.500	1/2	13/16	2 1/2	7/8	1 3/8	2 3/8	7
3 1/4	1	1	7/8-14	3/4-16	1 1/8	1.500	1/2	13/16	2 1/2	7/8	1 3/8	2 7/16	7 1/2
	3	1 3/8	1 1/4-12	1-14	1 5/8	2.000	5/8	1 1/8	3 1/4	1	1 5/8	2 11/16	8
4	1	1	7/8-14	3/4-16	1 1/8	1.500	1/2	13/16	2 1/2	7/8	1 3/8	2 7/16	7 1/2
	3	1 3/8	1 1/4-12	1-14	1 5/8	2.000	5/8	1 1/8	3 1/4	1	1 5/8	2 11/16	8
5	1	1	7/8-14	3/4-16	1 1/8	1.500	1/2	13/16	2 1/2	7/8	1 3/8	2 7/16	7 3/4
	3	1 3/8	1 1/4-12	1-14	1 5/8	2.000	5/8	1 1/8	3 1/4	21	1 5/8	2 11/16	8 1/4
6	1	1 3/8	1 1/4-12	1-14	1 5/8	2.000	5/8	1 1/8	3 1/4	1	1 5/8	2 7/8	8 3/4
	3	1 3/4	1 1/2-12	1 1/4-12	2	2.375	3/4	1 1/2	3 7/8	1 1/8	1 7/8	3 1/8	9 1/4
8	1	1 3/8	1 1/4-12	1-14	1 5/8	2.000	5/8	1 1/8	3 1/4	1	1 5/8	2 7/8	8 3/4
	3	1 3/4	1 1/2-12	1 1/4-12	2	2.375	3/4	1 1/2	3 7/8	1 1/8	1 7/8	3 1/8	9 1/4

Table 3 – Envelope and Mounting Dimensions

**Rod Clevis**

303 Stainless Steel

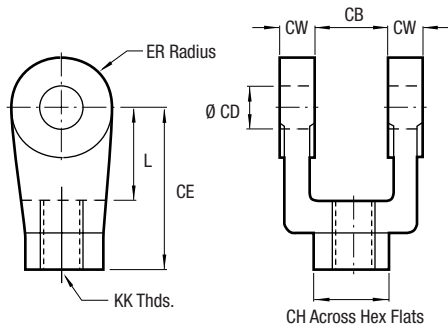

	1492220100	1492220200	1492220300	1492220400
CB	3/4	1 1/4	1 1/2	2
CD	0.500	0.750	1.000	1.375
CE	1 1/2	2 3/8	3 1/8	4 1/8
CH	1	1 1/4	1 1/2	2
CW	1/2	5/8	3/4	1
ER	1/2	3/4	1	1 3/8
KK	1/2-20	3/4-16	1-14	1 1/4-12
L	3/4	1 1/4	1 1/2	2 1/8

**Eye Bracket**

304 Stainless Steel

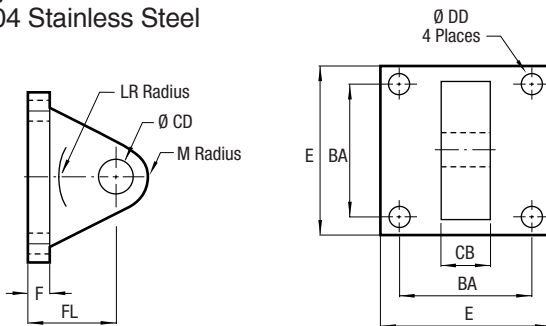

	1492230100	1492230200	1492230300
BA	1 5/8	2 9/16	3 1/4
CB	3/4	1 1/4	1 1/2
CD	0.500	0.750	1.000
DD	13/32	17/32	21/32
E	2 1/2	3 1/2	4 1/2
F	3/8	5/8	3/4
FL	1 1/8	1 7/8	2 1/4
LR	3/4	1 1/4	1 1/2
M	1/2	3/4	1

**Pin**

303 Stainless Steel

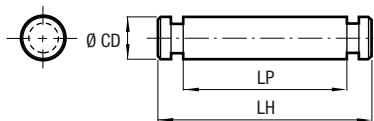

	0875600100	0875600200	0875600300	0875600400
CD	0.500	0.750	1.000	1.375
LH	2 7/32	3 1/8	3 3/4	5 5/8
LP	1 7/8	2 3/4	3 1/4	4 3/8

**Rod Alignment Coupler**

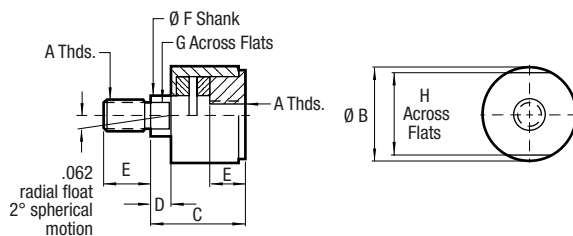

	1492240100	1492240200	1492240300
A	1/2-20	3/4-16	1-14
B	1 1/4	1 3/4	2 1/2
C	2	2 5/16	2 15/16
D	1/2	1/2	1/2
E	3/4	1 1/8	1 5/8
F	5/8	31/32	1 3/8
G	1/2	13/16	1 5/32
H	1 1/8	1 1/2	2 1/4
Maximum Pull (lbs.)	3,150	7,750	12,250

Made of 303 Stainless Steel, the Rod Alignment Coupler allows 1/16" of radial float and 2° of spherical movement. This prevents cylinder binding due to misalignment thus extending bearing and seal life, and permits greater tolerance between the center line of the cylinder and mating part for simplified installation.

## Excellent operating performance in a 1 1/8" bore size

**1 Piston Seals:** Nitrile lipseals are pressure energized and wear compensating. Their excellent lubrication retention characteristics lower seal friction and ensure long life.

**2 Piston:** Solid aluminum alloy, light-weight for low inertia, yet strong.

**4 Piston Rods:** 303 stainless steel, 40,000 PSI minimum yield, hard chrome plated, ground and polished.

**3 Head/Cap:** Precision machined from solid corrosion-resistant 304 stainless steel bar.

**5 Bearing Seal:** PTFE rod wiper provides positive wiping action and low friction. Nitrile lipseals are pressure energized and wear compensating for long life.

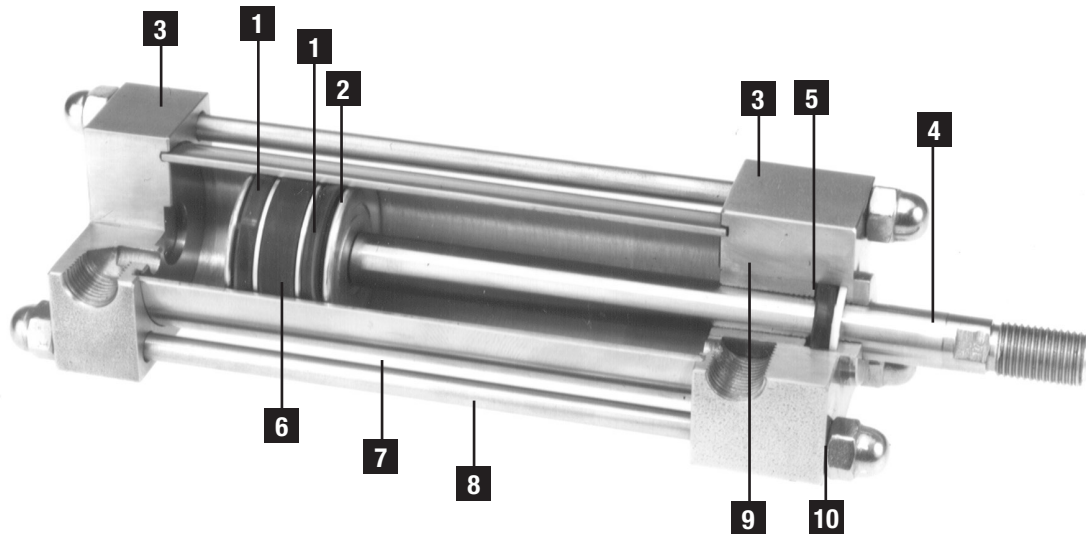

**6 Wear Strip:** PTFE and graphite composition for minimum friction, maximum wear and side load resistance. (Magnetic band under wear strip optional.)

**8 Tie Rods:** High-strength 303 stainless steel maintains compression on tube end seals.

**7 Tube:** Corrosion-resistant 304 stainless steel.

**9 Rod Bearing:** Incorporates a sintered bronze rod bearing which is pressed into the cylinder head.

**10 Acorn Nut:** Tie rod threads are covered by stainless steel acorn nuts which eliminates a bacteria hiding place.

## Optional Features

Cushions and bumpers are features also available on our 1 1/8" bore.

Cushions permit the trapping of cylinder exhaust volume prior to the completion of full rod extension or retraction. This volume is then metered through a finely tapered needle to deliver smooth, adjustable deceleration of the cylinder load.

**Note: Cushion block increases stroke related dimensions by .500 per end.**

**Cushions are not available on 1 1/8" bore with 1/2" diameter rod.**

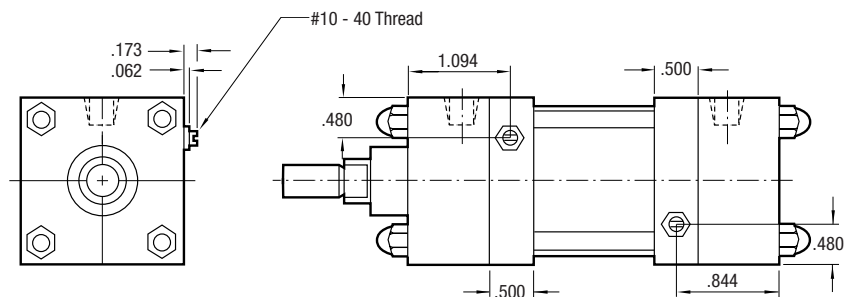

**No Mount Basic  
 Style T  
 (NFPA MX0)**

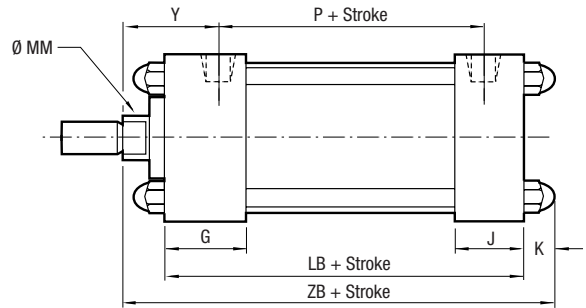
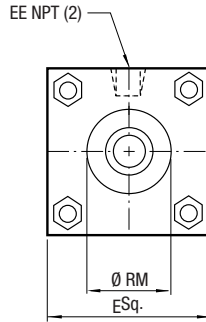
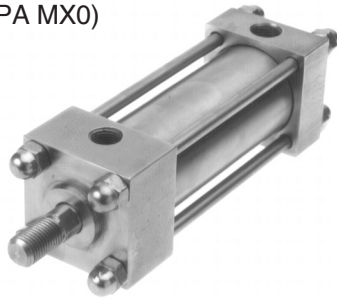

**Bolt Through Mount  
 Style C  
 (NFPA MS8)**

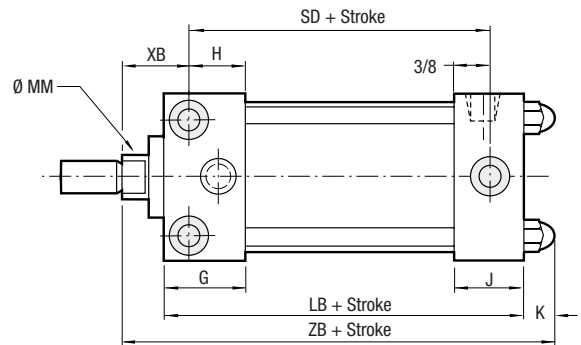
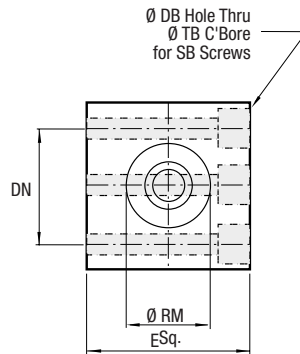

**Head Rectangular Flange Mount  
 Style J  
 (NFPA MF7)**

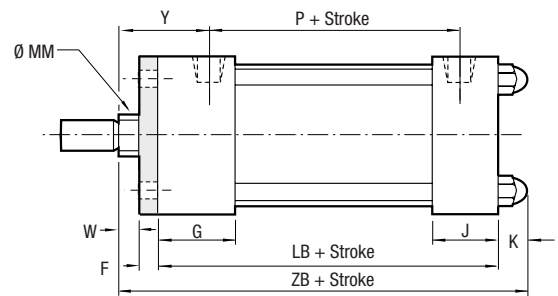
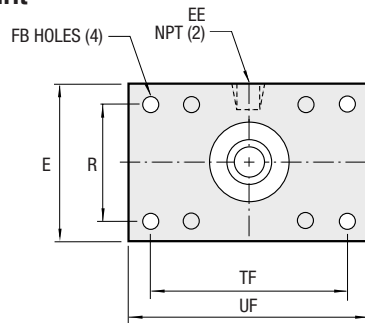

**Cap Rectangular Flange Mount  
 Style H  
 (NFPA MF2)**

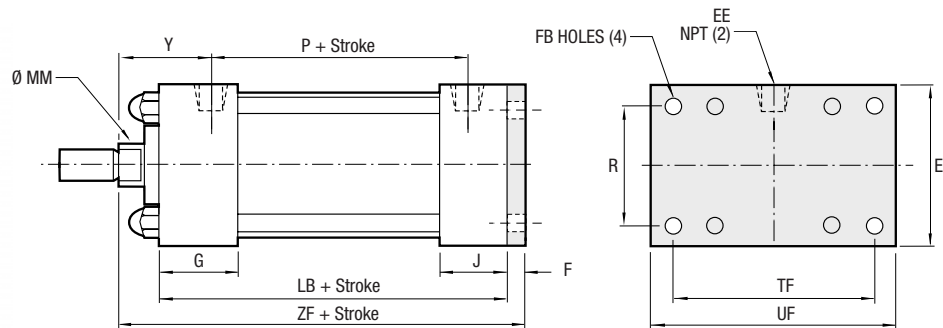
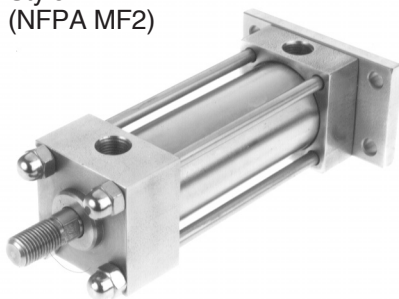



**Rod End Dimensions**

**Thread Style 6**  
 (NFPA Style FM)  
 Full Male

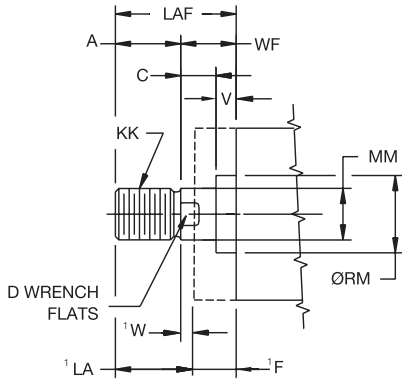

<sup>1</sup> FOR J (MF7) MOUNT ONLY

**Thread Style 8**  
 (NFPA Style IM)  
 Intermediate Male

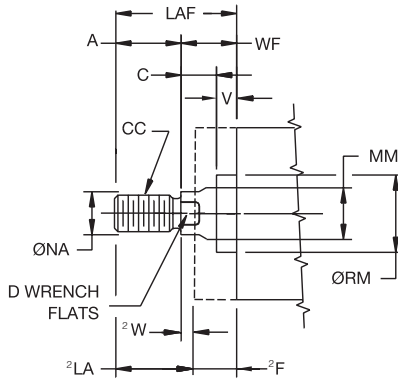

<sup>2</sup> FOR J (MF7) MOUNT ONLY

**Thread Style 9**  
 (NFPA Style SF)  
 Short Female

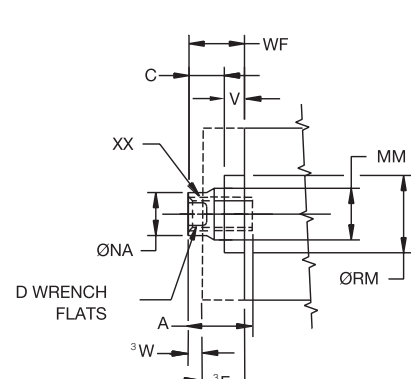

<sup>3</sup> FOR J (MF7) MOUNT ONLY

**“Special Thread” Style 3**

To order specify “Style 3” and give desired dimensions for CC or KK, A and W or WF. If otherwise special, furnish dimensioned sketch.

**Table 1 – Envelope & Mounting Dimensions**

Bore	C	DB	DN	E	EE	FB	G	H	J
1 1/8	1/4	13/64	1	1 1/2	1/8	7/32	7/8	5/8	5/8

Bore	K	R	TB	TF	UF	V	XB	Add Stroke		
								SD	ZB	ZF
1 1/8	13/32	1	21/64	2	2 1/2	1/8	5/8	1 3/4	2 5/8	2 7/8

**Table 2 – Rod Dimensions**

Bore Size	Rod No.	Rod Dia. MM	Thread			A	D	LAF	RM	SB	WF	Y	Add Stroke	
			Style 6 KK	Style 8 CC	Style 9 XX								LB	P
1 1/8	1	3/8	3/8-24	5/16-24	1/4-28	5/8	5/16	1	.750	#10	3/8	15/16	2 1/4	1 3/8
	3	1/2	1/2-20	7/16-20	3/8-24	3/4	7/16	1 1/8	1.000	#10	3/8	15/16	2 1/4	1 3/8

**Table 3 – Envelope and Mounting Dimensions**

**For J (MF7) Mount Only**

Bore Size	Rod No.	Rod Dia. MM	F	W	LA
1 1/8	1	3/8	1/4	1/8	3/4
	3	1/2	1/4	1/8	7/8

**Fixed Eye Mount**  
**Style BE**  
**(NFPA MP3)**

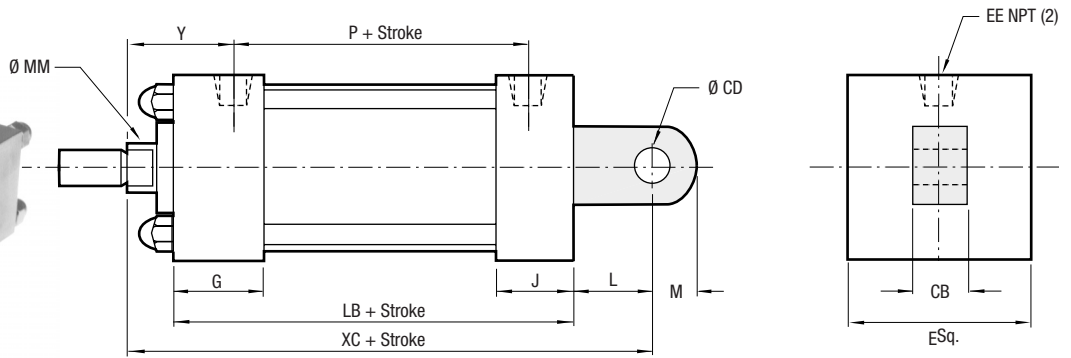
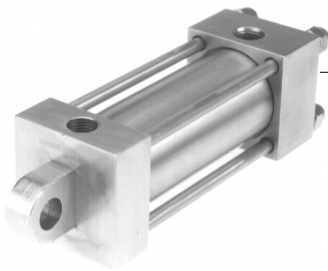

**Side Tap Mount**  
**Style F**  
**(NFPA MS9)**

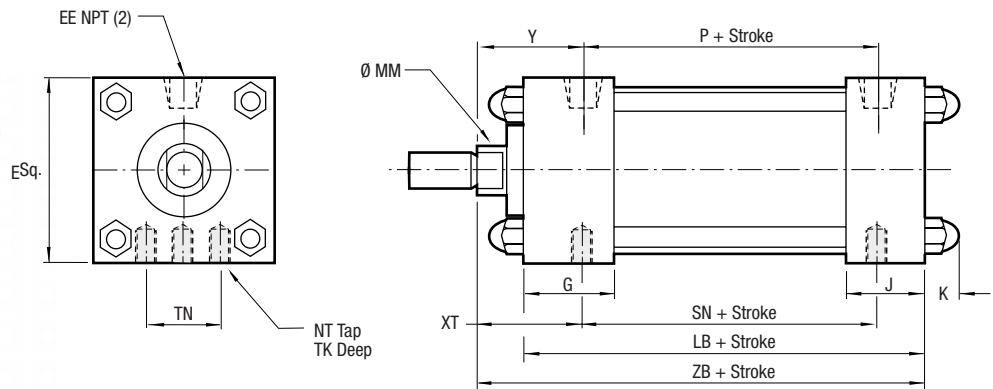

**Head Face Mount**  
**Style TE**  
**(NFPA MR1)**

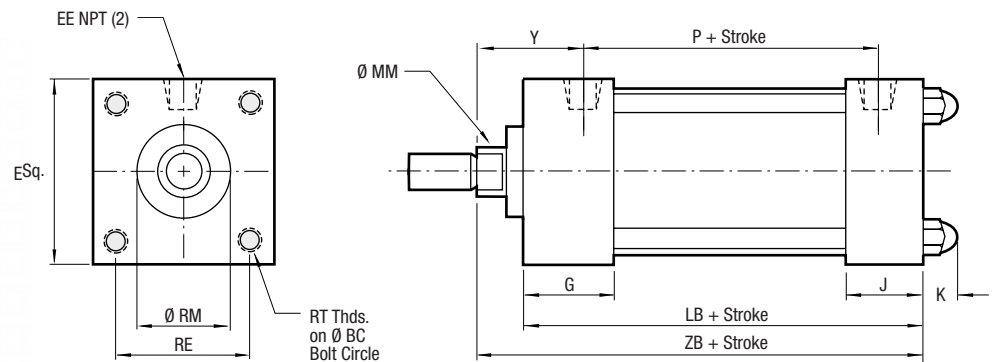

**Double Rod End**  
**Style KT**  
**(NFPA MDX0)**

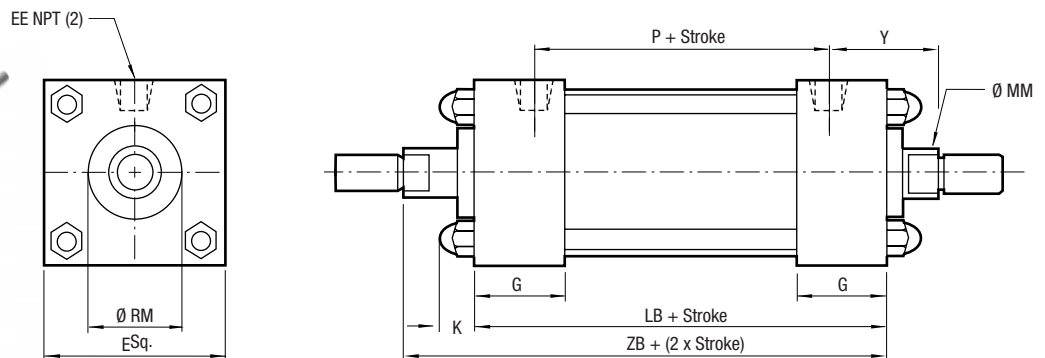

**Rod End Dimensions**

**Thread Style 6**  
(NFPA Style FM)  
Full Male

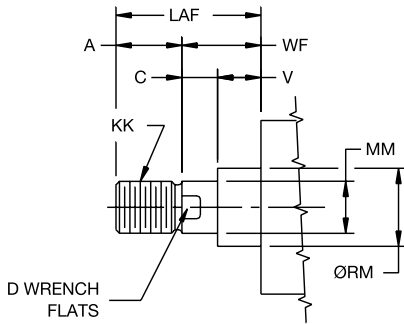

**Thread Style 8**  
(NFPA Style IM)  
Intermediate Male

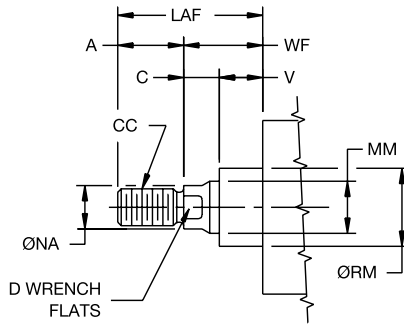

**Thread Style 9**  
(NFPA Style SF)  
Short Female

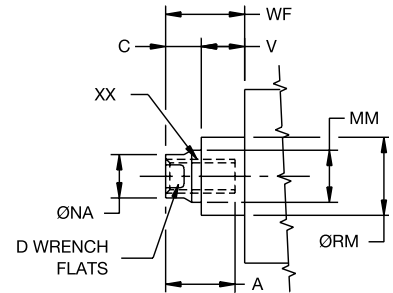

**“Special Thread” Style 3**

To order specify “Style 3” and give desired dimensions for CC or KK, A and W or WF. If otherwise special, furnish dimensioned sketch.

**Table 1 – Envelope & Mounting Dimensions**

Bore	BC	C	CB	CD	E	EE	G	J	K	L
1 1/8	1 19/32	1/4	.375	.375	1 1/2	1/8	7/8	5/8	13/32	7/16

Bore	M	NT	RE	RT	TK	TN	V	XT	Y	Add Stroke		
										SN	XC	ZB*
1 1/8	3/8	10-32	1 1/8	10-32	1/4	1	1/8	5/8	15/16	1 3/4	3 1/16	2 5/8

\*ZB dimension for double rod cylinder is 3 1/4 + 2 x stroke

**Table 2 – Rod Dimensions**

Bore Size	Rod. No.	Rod Dia. MM	Style 6 KK	Style 8 CC	Style 9 XX	A	D	LAF	RM	WF	Add Stroke	
											LB	P
1 1/8	1	3/8	3/8-24	5/16-24	1/4-28	5/8	5/16	1	.750	3/8	2 1/4	1 3/8
	3	1/2	1/2-20	7/16-20	3/8-24	3/4	7/16	1 1/8	1.000	3/8	2 1/4	1 3/8

**Table 3 – Envelope and Mounting Dimensions**

**Rod Eye**  
 303 Stainless Steel

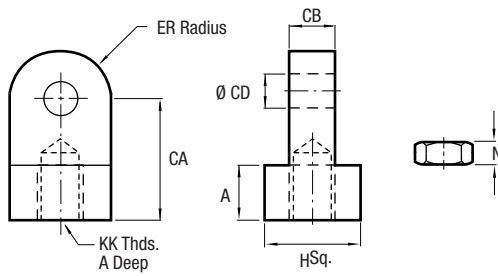

	1492220037	1492220050
A	7/16	7/16
CA	7/8	7/8
CB	3/8	3/8
CD	0.375	0.375
ER	3/8	3/8
H	3/4	3/4
KK	3/8-24	1/2-20
N	7/32	5/16

Includes Jam Nut

**Clevis Bracket**  
 304 Stainless Steel

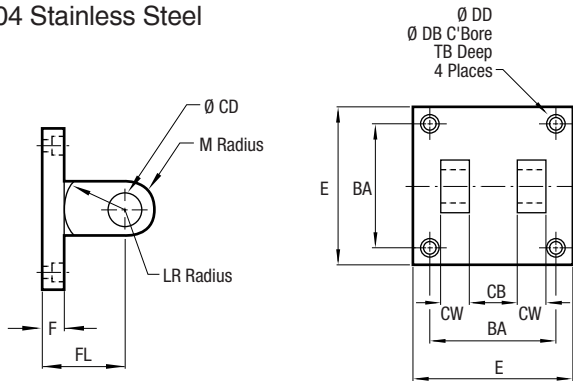

	1492230050
BA	1 1/8
CB	3/8
CD	0.375
CW	1/4
DB	21/64
DD	13/64
E	1 1/2
F	1/2
FL	1 1/8
LR	5/8
M	3/8
TB	1/3

**Pivot Pin**  
 303 Stainless Steel

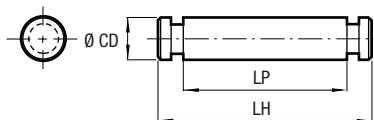

	0875600050
CD	0.375
LH	1 1/4
LP	1 1/32

Use with 1449220037,  
 1449220050, 1492230050

**Rod Alignment Coupler**

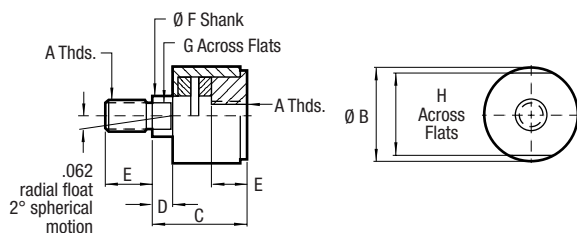

	1492240050
A	3/8-24
B	7/8
C	1 1/4
D	1/4
E	5/8
F	3/8
G	5/16
H	3/4
Maximum Pull (lbs.)	1,375

Made of 303 Stainless Steel, the Rod Alignment Coupler allows 1/16" of radial float and 2° of spherical movement. This prevents cylinder binding due to misalignment thus extending bearing and seal life, and permits greater tolerance between the center line of the cylinder and mating part for simplified installation.

**Piston Rod – Stroke Selection Chart**

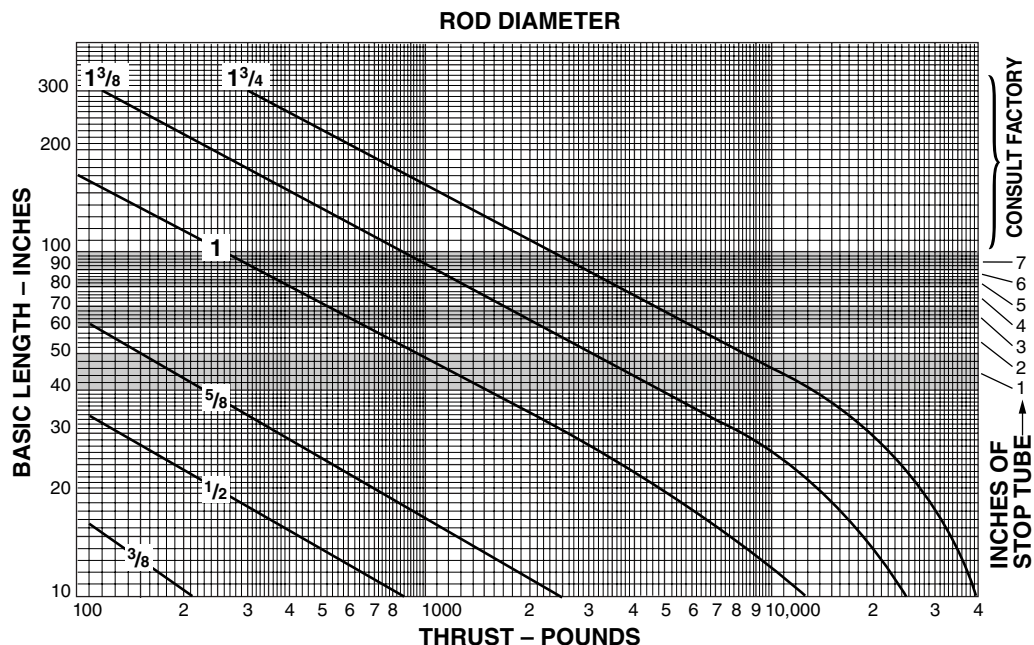

**How To Use The Chart**

The selection of a piston rod for thrust (push) conditions requires the following steps:

1. Determine the type of cylinder mounting style and rod end connection to be used. Then consult the chart below and find the "stroke factor" that corresponds to the conditions used.
2. Using this stroke factor, determine the "basic length" from the equation:

$$\text{Basic Length} = \frac{\text{Actual Stroke} \times \text{Stroke Factor}}{\text{Stroke}}$$

The graph is prepared for standard rod extensions beyond the face of the gland retainer. For rod extensions greater than standard, add the increase to the stroke in arriving at the "basic length."

3. Find the load imposed for the thrust application by multiplying the full bore area of the cylinder by the system pressure.
4. Enter the graph along the values of "basic length" and "thrust" as found above and note the point of intersection:

- a) The correct piston rod size is read from the diagonally curved line labeled "Rod Diameter" next above the point of intersection.
- b) The required length of stop tube is read from the right of the graph by following the shaded band in which the point of intersection lies.
- c) If required length of stop tube is in the region labeled "consult factory," submit the following information for an individual analysis.
  - 1) Cylinder mounting style.
  - 2) Rod end connection and method of guiding load.
  - 3) Bore, required stroke, length of rod extension (Dim. "LA") if greater than standard, and series of cylinder used.
  - 4) Mounting position of cylinder. (Note: if at an angle or vertical, specify direction of piston rod.)
  - 5) Operating pressure of cylinder if limited to less than standard pressure for cylinder selected.

Recommended Mounting Styles for Maximum Stroke and Thrust Loads	Rod End Connection	Case	Stroke Factor
<b>Groups 1 or 3</b> Long stroke cylinders for thrust loads should be mounted using a heavy-duty mounting style at one end, firmly fixed and aligned to take the principal force. Additional mounting should be specified at the opposite end, which should be used for alignment and support. An intermediate support may also be desirable for long stroke cylinders mounted horizontally.	FIXED AND RIGIDLY GUIDED	I	.50
	PIVOTED AND RIGIDLY GUIDED	II	.70
	SUPPORTED BUT NOT RIGIDLY GUIDED	III	2.00
<b>Group 2</b> Style D-Trunnion on Head	PIVOTED AND RIGIDLY GUIDED	IV	1.00
Style DB-Trunnion on Cap or Style BB-Clevis on Cap	PIVOTED AND RIGIDLY GUIDED	V	2.00

Magnetically operated, non-contact sensing system.

Consists of a magnet in the piston, and a sensing switch clamped on the cylinder tie rod.

One or more switches may be mounted to provide an indication of piston position.

Switches are provided with vinyl molded cable.

Adjustable mounting brackets allow for switches to be securely positioned anywhere along the range of piston travel.

Indicator light facilitates installation and troubleshooting.

Several switches may be mounted to control or initiate any sequence function.

Mounting brackets standard with switches.



**Switch & Mounting Bracket Dimensions**

Current Rating	Sensor Type	Bore Sizes	
		1 1/8"-2 1/2" Bore	2"-8" Bore
.5 amp max	Reed	L077610000	—
1 amp max	Reed	—	L077620000
4 amp max	Reed	—	L077630000
.5 amp max	NPN	L077650000	L077670000
.5 amp max	PNP	L077640000	L077660000

**1 1/8" to 2 1/2" Bores Sizes (.5 amp max)**

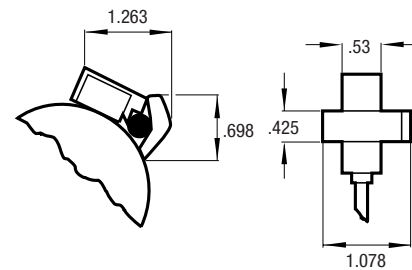

**2" to 8" Bores Sizes**

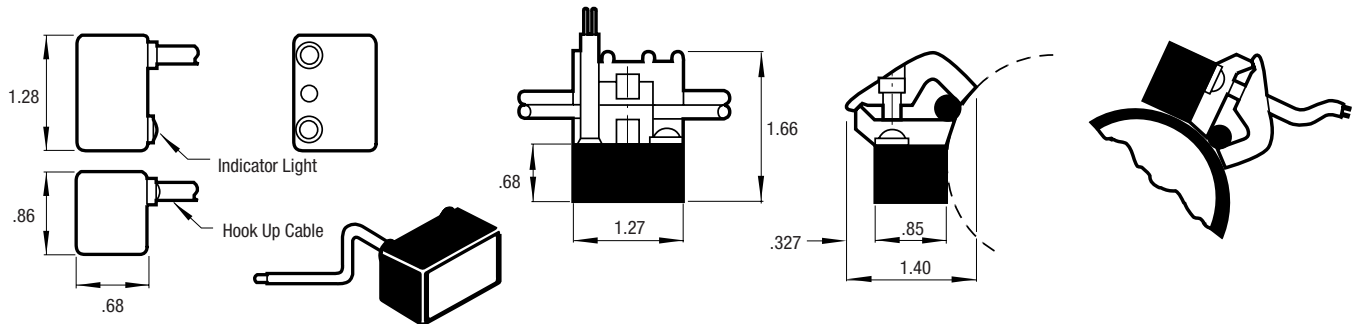

**NOTE: See following page for switch specifications and wiring diagrams.**

**⚠ Caution**

- Use an ampmeter to test reed switch current. Testing devices such as incandescent light bulbs may subject the reed switch to high in-rush loads.
- **NOTE:** When checking an unpowered reed switch for continuity with a digital ohmmeter the resistance reading will change from infinity to a very large resistance (2 M ohm) when the switch is activated. This is due to the presence of a diode in the reed switch.
- Anti-magnetic shielding is recommended for reed switches exposed to high external RF or magnetic fields.
- The magnetic field strength of the piston magnet is designed to operate with our switches. Other manufacturers' switches or sensors may not operate correctly in conjunction with these magnets.
- Current capabilities are relative to operational temperatures.
- Use relay coils for reed switch contact protection.
- The operation of some 120 VAC PLC's (especially some older Allen-Bradley PLC's) can overload the reed switch. The switch may fail to release after the piston magnet has passed. This problem may be corrected by the placement of a 700 to 1K OHM resistor between the switch and the PLC input terminal. Consult the manufacturer of the PLC for appropriate circuit.
- Switches with long wire leads (greater than 15 feet) can cause capacitance build-up and sticking will result. Attach a resistor in series with the reed switch (the resistor should be installed as close as possible to the switch). The resistor should be selected such that  $R \text{ (ohms)} > E/0.3$ .

**Application Recommendations and Precautions**

To provide maximum reliability.

1. Always stay within the specifications and power rating limitations of the unit installed.
2. Primary and control circuit wiring should not be mixed in the same conduit. Motors will produce high pulses that will be introduced into the control wiring if the wiring is carried in the same conduit.
3. Never connect the switch without a load present. The switch will be destroyed.
4. Some electrical loads may be capacitive. Capacitive loading may occur due to distributed capacity in cable runs over 25 feet. Use switch Model LO77630000 whenever capacitive loading may occur.

In order to obtain optimum performance and long life, magnetically operated limit switches should not be subjected to: (1) strong magnetic fields, (2) extreme temperature, and (3) excessive ferrous filing or chip buildup.

Improper wiring may damage or destroy the switch. The wiring diagram, along with the listed power ratings, must be carefully observed before connecting power to the switch.

Lower power switches are designed for signaling electronic circuits. Do not use on relay loads or with incandescent bulbs. Resistive loads only.

**Specifications**

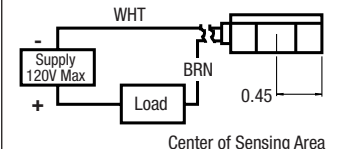
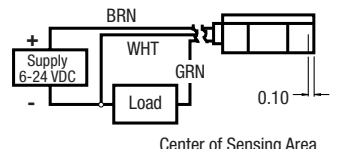
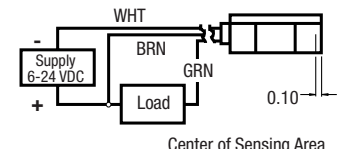
Switch Model	LO77610000	LO77640000	LO77650000
<b>Bore Sizes</b>	1 1/8" thru 2 1/2"	1 1/8" thru 2 1/2"	1 1/8" thru 2 1/2"
<b>Switch Type</b>	Reed Switch, 1MOV & Light	Hall Effect & Light, Sourcing PNP	Hall Effect & Light, Sinking NPN
<b>Function</b>	SPST Normally Open	Normally Open	Normally Open
<b>Switching Voltage</b>	5-120 VDC/VAC, 50/60 Hz	6-24 VDC	6-24 VDC
<b>Switching Current</b>	.5 Amp Max, .005 Amp Min	.5 Amp Max	.5 Amp Max
<b>Switching Power</b>	10 VA	12 Watts Max	12 Watts Max
<b>Max Voltage Drop</b>	3.5 Volts	.5 Volts	.5 Volts
<b>Magnetic Sensitivity</b>	85 Gauss	85 Gauss	85 Gauss
<b>Enclosure Classification</b>	NEMA 6 & CSA Approved	NEMA 6 & CSA Approved	NEMA 6 & CSA Approved
<b>Temperature Range</b>	-22°F to +176°F	-22°F to +176°F	-22°F to +176°F
<b>Wiring Diagrams</b>			

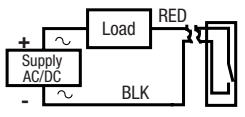
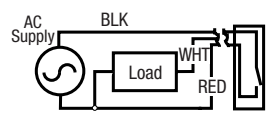
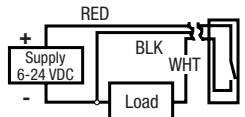
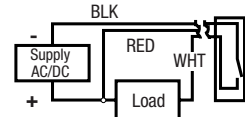
Switch Model	LO77620000	LO77630000	LO77660000	LO77670000
<b>Bore Sizes</b>	2" thru 8"	2" thru 8"	2" thru 8"	2" thru 8"
<b>Switch Type</b>	Reed Switch, 1MOV & Light	Reed Switch, 1MOV & Light, 3 Wire	Hall Effect & Light, Sourcing PNP	Hall Effect & Light, Sinking NPN
<b>Function</b>	Normally Open	Normally Open	Normally Open	Normally Open
<b>Switching Voltage</b>	5-240 VDC/VAC, 50/60 Hz	24-240 VAC, 50/60 Hz	6-24 VDC	6-24 VDC
<b>Switching Current</b>	1 Amp Max	4 Amp Max, 50 Amp Inrush	1 Amp Max	1 Amp Max
<b>Switching Power</b>	30 Watts Max	100 Watts Max	24 Watts Max	24 Watts Max
<b>Max Voltage Drop</b>	3 Volts	N/A	.5 Volts	.5 Volts
<b>Magnetic Sensitivity</b>	85 Gauss, Parallel	85 Gauss, Parallel	85 Gauss, Parallel	85 Gauss, Parallel
<b>Enclosure Classification</b>	NEMA 6 & CSA Approved	NEMA 6 & CSA Approved	NEMA 6 & CSA Approved	NEMA 6 & CSA Approved
<b>Temperature Range</b>	-22°F to +176°F	-22°F to +176°F	-22°F to +176°F	-22°F to +176°F
<b>Wiring Diagrams</b>				

<sup>1</sup>Metal Oxide Varsistor Surge Suppression. NOTE: All Switches are supplied with 9 foot leads.

How to Order

How to Order Series SA Cylinders

Atlas Series SA pneumatic cylinders can be specified by model number by using the table below.

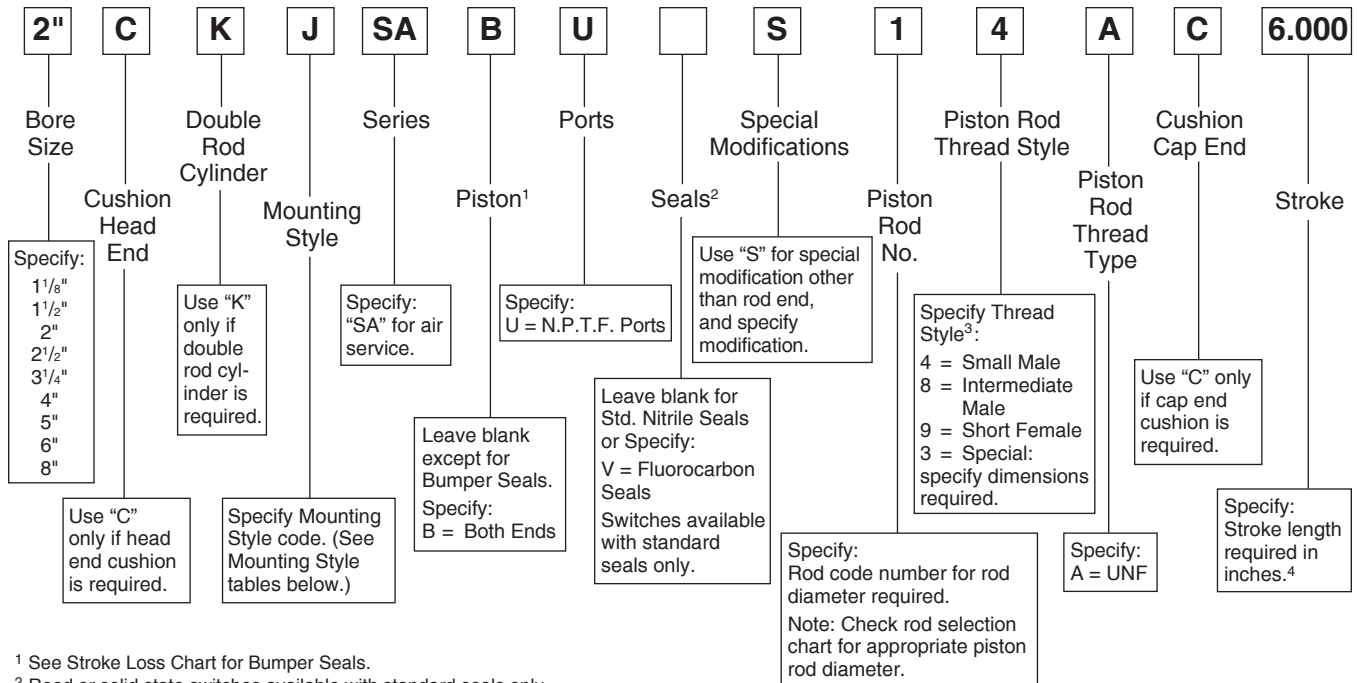

<sup>1</sup> See Stroke Loss Chart for Bumper Seals.  
<sup>2</sup> Reed or solid state switches available with standard seals only.  
<sup>3</sup> For 1 1/8" Bore Rod thread 4 not available, Rod thread 6 is full male option.  
<sup>4</sup> In case of stop tube, call out gross stroke length (net stroke + stop tube length).

Cylinder Mounting Styles - 1 1/8" Bore

Mounting Style Code	N.F.P.A. Style	Mounting Description
T	MX0	No Mount (Basic)
C	MS8	Bolt Through
F	MS9	Side Tapped
TE	MR1	Head Face
J	MF7	Head Rectangular Flange
H	MF2	Cap Rectangular Flange
BE	MP3	Cap Fixed Eye

Cylinder Mounting Styles - 1 1/2" - 8" Bores

Mounting Style Code	N.F.P.A. Style	Mounting Description
T	MX0	No Mount (Basic)
F	MS4	Side Tapped
J	MF1	Head Rect. Flange (1 1/2"-8")
H	MF2	Cap Rect. Flange (1 1/2"-8")
D	MT1	Head Trunnion
DB	MT2	Cap Trunnion
BB	MP1	Cap Fixed Clevis
JB	ME3	Head Square (8" only)
HB	ME4	Cap Square (8" only)



**How to Order Atlas Series SA Cylinders with Switches**

Switches are not mounted to the cylinder prior to shipment. When ordering a cylinder to accommodate a switch:

1. Derive a proper model number as shown in the table above.
2. Place an "S" in the special modification column of the model number.
3. Underneath the model number specify:
  - 1) Cylinder prepared for switch.
  - 2) If switches and switch bracket are required specify the switch code and quantity as listed below.

Code	Description	Quantity
PSR1	Reed Switch Assembly	Number of Switches Specify Quantity (1-9)
PSP1	Solid State (PNP Sourcing) Assembly	
PSN1	Solid State (NPN Sinking) Assembly	
CPFS	Cylinder Prepared for Switch	-

**Example A:** For cylinder prepared for switch only  
2" CJS AUS 14AC x 6.00  
S=CPFS

**Example B:** For cylinder prepared for and supplied with  
limit switches  
2" CJS AUS14AX x 6.00  
S=with PSR1 limit switch Qty (2)

**Optional Piston Bumper Seals**

Impact dampening Piston Bumper Seals are optional on Series SA cylinders from 1 1/8" through 8" bore. Piston Bumper Seals have a minimum effect on stroke length. The Stroke Loss Chart below gives typical overall stroke loss at various system pressures.

To determine the stroke loss at either end of the cylinder, divide the values by two. Bumper Seals are only available on both sides of the piston.

**Stroke Loss Chart**

Bore	0 PSI	20 PSI	40 PSI	60 PSI	80 PSI	100 PSI
1 1/8"	.12	.08	.06	.03	.02	0
1 1/2" <sup>1</sup>	.12	.04	.03	.02	.01	0
2"	.12	.10	.06	.03	.02	0
2 1/2"	.16	.10	.08	.04	.02	0
3 1/4"	.18	.10	.08	.04	.02	0
4"	.20	.14	.10	.06	.02	0
5"	.22	.14	.10	.06	.02	0
6"	.28	.20	.13	.07	.03	0
8"	.32	.22	.14	.08	.04	0

<sup>1</sup> Piston Bumper Seals are not available 1 1/2" bore with rod code 2.

**Notes**

**Notes**

## Safety Guide for Selecting and Using Hydraulic, Pneumatic Cylinders and Their Accessories

**WARNING:** ⚠ FAILURE OF THE CYLINDER, ITS PARTS, ITS MOUNTING, ITS CONNECTIONS TO OTHER OBJECTS, OR ITS CONTROLS CAN RESULT IN:

- Unanticipated or uncontrolled movement of the cylinder or objects connected to it.
- Falling of the cylinder or objects held up by it.
- Fluid escaping from the cylinder, potentially at high velocity.

**THESE EVENTS COULD CAUSE DEATH OR PERSONAL INJURY BY, FOR EXAMPLE, PERSONS FALLING FROM HIGH LOCATIONS, BEING CRUSHED OR STRUCK BY HEAVY OR FAST MOVING OBJECTS, BEING PUSHED INTO DANGEROUS EQUIPMENT OR SITUATIONS, OR SLIPPING ON ESCAPED FLUID.**

Before selecting or using Parker Hannifin Corporation (the Company) cylinders or related accessories, it is important that you read, understand and follow the following safety information. Training is advised before selecting and using the Company's products.

### 1.0 General Instructions

**1.1 Scope** – This safety guide provides instructions for selecting and using (including assembling, installing, and maintaining) cylinder products. This safety guide is a supplement to and is to be used with the specific Company publications for the specific cylinder products that are being considered for use.

**1.2 Fail Safe** – Cylinder products can and do fail without warning for many reasons. All systems and equipment should be designed in a fail-safe mode so that if the failure of a cylinder product occurs people and property won't be endangered.

**1.3 Distribution** – Provide a free copy of this safety guide to each person responsible for selecting or using cylinder products. Do not select or use the Company's cylinders without thoroughly reading and understanding this safety guide as well as the specific Company publications for the products considered or selected.

**1.4 User Responsibility** – Due to very wide variety of cylinder applications and cylinder operating conditions, the Company does not warrant that any particular cylinder is suitable for any specific application. This safety guide does not analyze all technical parameters that must be considered in selecting a product. The hydraulic and pneumatic cylinders outlined in this catalog are designed to the Company's design guidelines and do not necessarily meet the design guideline of other agencies such as American Bureau of Shipping, ASME Pressure Vessel Code etc. The user, through its own analysis and testing, is solely responsible for:

- Making the final selection of the cylinders and related accessories.
- Determining if the cylinders are required to meet specific design requirements as required by the Agency(s) or industry standards covering the design of the user's equipment.
- Assuring that the user's requirements are met, OSHA requirements are met, and safety guidelines from the applicable agencies such as but not limited to ANSI are followed and that the use presents no health or safety hazards.
- Providing all appropriate health and safety warnings on the equipment on which the cylinders are used.

**1.5 Additional Questions** – Call the appropriate Company technical service department if you have any questions or require any additional information. See the Company publication for the product being considered or used, or call 1-847-298-2400, or go to [www.parker.com](http://www.parker.com), for telephone numbers of the appropriate technical service department.

### 2.0 Cylinder and Accessories Selection

**2.1 Seals** – Part of the process of selecting a cylinder is the selection of seal compounds. Before making this selection, consult the "seal information page(s)" of the publication for the series of cylinders of interest.

The application of cylinders may allow fluids such as cutting fluids, wash down fluids etc. to come in contact with the external area of the cylinder. These fluids may attack the piston rod wiper and or the primary seal and must be taken into account when selecting and specifying seal compounds.

Dynamic seals will wear. The rate of wear will depend on many operating factors. Wear can be rapid if a cylinder is mis-aligned or if the cylinder has been improperly serviced. The user must take seal wear into consideration in the application of cylinders.

**2.2 Piston Rods** – Possible consequences of piston rod failure or separation of the piston rod from the piston include, but are not limited to are:

- Piston rod and or attached load thrown off at high speed.
- High velocity fluid discharge.
- Piston rod extending when pressure is applied in the piston retract mode.

Piston rods or machine members attached to the piston rod may move suddenly and without warning as a consequence of other conditions occurring to the machine such as, but not limited to:

- Unexpected detachment of the machine member from the piston rod.

- Failure of the pressurized fluid delivery system (hoses, fittings, valves, pumps, compressors) which maintain cylinder position.
- Catastrophic cylinder seal failure leading to sudden loss of pressurized fluid.
- Failure of the machine control system.

Follow the recommendations of the "Piston Rod Selection Chart and Data" in the publication for the series of cylinders of interest. The suggested piston rod diameter in these charts must be followed in order to avoid piston rod buckling.

Piston rods are not normally designed to absorb bending moments or loads which are perpendicular to the axis of piston rod motion. These additional loads can cause the piston rod to fail. If these types of additional loads are expected to be imposed on the piston rod, their magnitude should be made known to our engineering department.

The cylinder user should always make sure that the piston rod is securely attached to the machine member.

On occasion cylinders are ordered with double rods (a piston rod extended from both ends of the cylinder). In some cases a stop is threaded on to one of the piston rods and used as an external stroke adjuster. On occasions spacers are attached to the machine member connected to the piston rod and also used as a stroke adjuster. In both cases the stops will create a pinch point and the user should consider appropriate use of guards. If these external stops are not perpendicular to the mating contact surface, or if debris is trapped between the contact surfaces, a bending moment will be placed on the piston rod, which can lead to piston rod failure. An external stop will also negate the effect of cushioning and will subject the piston rod to impact loading. Those two (2) conditions can cause piston rod failure. Internal stroke adjusters are available with and without cushions. The use of external stroke adjusters should be reviewed with our engineering department.

The piston rod to piston and the stud to piston rod threaded connections are secured with an anaerobic adhesive. The strength of the adhesive decreases with increasing temperature. Cylinders which can be exposed to temperatures above +250°F (+121°C) are to be ordered with a non studded piston rod and a pinned piston to rod joint.

**2.3 Cushions** – Cushions should be considered for cylinder applications when the piston velocity is expected to be over 4 inches/second.

Cylinder cushions are normally designed to absorb the energy of a linear applied load. A rotating mass has considerably more energy than the same mass moving in a linear mode. Cushioning for a rotating mass application should be reviewed by our engineering department.

**2.4 Cylinder Mountings** – Some cylinder mounting configurations may have certain limitations such as but not limited to minimum stroke for side or foot mounting cylinders or pressure de-ratings for certain mounts. Carefully review the catalog for these types of restrictions.

Always mount cylinders using the largest possible high tensile alloy steel socket head cap screws that can fit in the cylinder mounting holes and torque them to the manufacturer's recommendations for their size.

**2.5 Port Fittings** – Hydraulic cylinders applied with meter out or deceleration circuits are subject to intensified pressure at piston rod end.

The rod end pressure is approximately equal to:

$$\frac{\text{operating pressure} \times \text{effective cap end area}}{\text{effective rod end piston area}}$$

Contact your connector supplier for the pressure rating of individual connectors.

### 3.0 Cylinder and Accessories Installation and Mounting

#### 3.1 Installation

**3.1.1** – Cleanliness is an important consideration, and cylinders are shipped with the ports plugged to protect them from contaminants entering the ports. These plugs should not be removed until the piping is to be installed. Before making the connection to the cylinder ports, piping should be thoroughly cleaned to remove all chips or burrs which might have resulted from threading or flaring operations.

**3.1.2** – Cylinders operating in an environment where air drying materials are present such as fast-drying chemicals, paint, or weld splatter, or other hazardous conditions such as excessive heat, should have shields installed to prevent damage to the piston rod and piston rod seals.

**3.1.3** – Proper alignment of the cylinder piston rod and its mating component on the machine should be checked in both the extended and retracted positions. Improper alignment will result in excessive rod gland and/or cylinder bore wear. On fixed mounting cylinders attaching the piston rod while the rod is retracted will help in achieving proper alignment.

**3.1.4** – Sometimes it may be necessary to rotate the piston rod in order to thread the piston rod into the machine member. This operation must always be done with zero pressure being applied to either side of the piston. Failure to follow this procedure may result in loosening the piston to rod-threaded connection. In some rare cases the turning of the piston rod may rotate a threaded piston rod gland and loosen it from the cylinder head. Confirm that this condition is not occurring. If it does, re-tighten the piston rod gland firmly against the cylinder head.

For double rod cylinders it is also important that when attaching or detaching the piston rod from the machine member that the torque be applied to the piston rod end of the cylinder that is directly attaching to the machine member with the opposite end unrestrained. If the design of the machine is such that only the rod end of the cylinder opposite to where the rod attaches to the machine member can be rotated, consult the factory for further instructions.

### **3.2 Mounting Recommendations**

**3.2.1** – Always mount cylinders using the largest possible high tensile alloy steel socket head screws that can fit in the cylinder mounting holes and torque them to the manufacturer's recommendations for their size.

**3.2.2** – Side-Mounted Cylinders – In addition to the mounting bolts, cylinders of this type should be equipped with thrust keys or dowel pins located so as to resist the major load.

**3.2.3** – Tie Rod Mounting – Cylinders with tie rod mountings are recommended for applications where mounting space is limited. The standard tie rod extension is shown as BB in dimension tables. Longer or shorter extensions can be supplied. Nuts used for this mounting style should be torqued to the same value as the tie rods for that bore size.

**3.2.4** – Flange Mount Cylinders – The controlled diameter of the rod gland extension on head end flange mount cylinders can be used as a pilot to locate the cylinders in relation to the machine. After alignment has been obtained, the flanges may be drilled for pins or dowels to prevent shifting.

**3.2.5** – Trunnion Mountings – Cylinders require lubricated bearing blocks with minimum bearing clearances. Bearing blocks should be carefully aligned and rigidly mounted so the trunnions will not be subjected to bending moments. The rod end should also be pivoted with the pivot pin in line and parallel to axis of the trunnion pins.

**3.2.6** – Clevis Mountings – Cylinders should be pivoted at both ends with centerline of pins parallel to each other. After cylinder is mounted, be sure to check to assure that the cylinder is free to swing through its working arc without interference from other machine parts.

### **4.0 Cylinder and Accessories Maintenance, Troubleshooting and Replacement**

**4.1 Storage** – At times cylinders are delivered before a customer is ready to install them and must be stored for a period of time. When storage is required the following procedures are recommended.

**4.1.1** – Store the cylinders in an indoor area which has a dry, clean and noncorrosive atmosphere. Take care to protect the cylinder from both internal corrosion and external damage.

**4.1.2** – Whenever possible cylinders should be stored in a vertical position (piston rod up). This will minimize corrosion due to possible condensation which could occur inside the cylinder. This will also minimize seal damage.

**4.1.3** – Port protector plugs should be left in the cylinder until the time of installation.

**4.1.4** – If a cylinder is stored full of hydraulic fluid, expansion of the fluid due to temperature changes must be considered. Installing a check valve with free flow out of the cylinder is one method.

**4.1.5** – When cylinders are mounted on equipment that is stored outside for extended periods, exposed unpainted surfaces, e.g. piston rod, must be coated with a rust-inhibiting compound to prevent corrosion.

### **4.2 Cylinder Trouble Shooting**

#### **4.2.1 – External Leakage**

**4.2.1.1** – Rod seal leakage can generally be traced to worn or damaged seals. Examine the piston rod for dents, gouges or score marks, and replace piston rod if surface is rough.

Rod seal leakage could also be traced to gland wear. If clearance is excessive, replace rod bushing and seal. Rod seal leakage can also be traced to seal deterioration. If seals are soft or gummy or brittle, check compatibility of seal material with lubricant used if air cylinder, or operating fluid if hydraulic cylinder. Replace with seal material, which is compatible with these fluids. If the seals are hard or have lost elasticity, it is usually due to exposure to temperatures in excess of 165°F. (+74°C). Shield the cylinder from the heat source to limit temperature to 350°F. (+177°C.) and replace with fluorocarbon seals.

**4.2.1.2** – Cylinder body seal leak can generally be traced to loose tie rods. Torque the tie rods to manufacturer's recommendation for that bore size.

Excessive pressure can also result in cylinder body seal leak. Determine maximum pressure to rated limits. Replace seals and retorque tie rods as in paragraph above. Excessive pressure can also result in cylinder body seal leak. Determine if the pressure rating of the cylinder has been exceeded. If so, bring the operating pressure down to the rating of the cylinder and have the tie rods replaced.

Pinched or extruded cylinder body seal will also result in a leak. Replace cylinder body seal and retorque as in paragraph above.

Cylinder body seal leakage due to loss of radial squeeze which shows up in the form of flat spots or due to wear on the O.D. or I.D. – Either of these are symptoms of normal wear due to high cycle rate or length of service. Replace seals as per paragraph above.

#### **4.2.2 – Internal Leakage**

**4.2.2.1** – Piston seal leak (by-pass) 1 to 3 cubic inches per minute leakage is considered normal for piston ring construction. Virtually no static leak with lipseal type seals on piston should be expected. Piston seal wear is a usual cause of piston seal leakage. Replace seals as required.

**4.2.2.2** – With lipseal type piston seals excessive back pressure due to over-adjustment of speed control valves could be a direct cause of rapid seal wear. Contamination in a hydraulic system can result in a scored cylinder bore, resulting in rapid seal wear. In either case, replace piston seals as required.

**4.2.2.3** – What appears to be piston seal leak, evidenced by the fact that the cylinder drifts, is not always traceable to the piston. To make sure, it is suggested that one side of the cylinder piston be pressurized and the fluid line at the opposite port be disconnected. Observe leakage. If none is evident, seek the cause of cylinder drift in other component parts in the circuit.

#### **4.2.3 – Cylinder Fails to Move the Load**

**4.2.3.1** – Pneumatic or hydraulic pressure is too low. Check the pressure at the cylinder to make sure it is to circuit requirements.

**4.2.3.2** – Piston Seal Leak – Operate the valve to cycle the cylinder and observe fluid flow at valve exhaust ports at end of cylinder stroke. Replace piston seals if flow is excessive.

**4.2.3.3** – Cylinder is undersized for the load – Replace cylinder with one of a larger bore size.

#### **4.3 Erratic or Chatter Operation**

**4.3.1** – Excessive friction at rod gland or piston bearing due to load misalignment – Correct cylinder-to-load alignment.

**4.3.2** – Cylinder sized too close to load requirements – Reduce load or install larger cylinder.

**4.3.3** – Erratic operation could be traced to the difference between static and kinetic friction. Install speed control valves to provide a back pressure to control the stroke.

**4.4 Cylinder Modifications, Repairs, or Failed Component** – Cylinders as shipped from the factory are not to be disassembled and or modified. If cylinders require modifications, these modifications must be done at company locations or by the Company's certified facilities. The Cylinder Division Engineering Department must be notified in the event of a mechanical fracture or permanent deformation of any cylinder component (excluding seals). This includes a broken piston rod, tie rod, mounting accessory or any other cylinder component. The notification should include all operation and application details. This information will be used to provide an engineered repair that will prevent recurrence of the failure.

It is allowed to disassemble cylinders for the purpose of replacing seals or seal assemblies. However, this work must be done by strictly following all the instructions provided with the seal kits.

**Notes**

---

**Notes**

## Offer of Sale

The items described in this document and other documents or descriptions provided by Parker Hannifin Corporation, its subsidiaries and Divisions ("Company") and its authorized distributors, are hereby offered for sale at prices to be established by the Company, its subsidiaries and its authorized distributors. This offer and its acceptance by any customer ("Buyer") shall be governed by all of the following Terms and Conditions. Buyer's order for any such item, when communicated to the Company, its subsidiary or an authorized distributor ("Seller") verbally or in writing, shall constitute acceptance of this offer.

**1. Terms and Conditions of Sale:** All descriptions, quotations, proposals, offers, acknowledgments, acceptances and sales of Seller's products are subject to and shall be governed exclusively by the terms and conditions stated herein. Buyer's acceptance of any offer to sell is limited to these terms and conditions. Any terms or conditions in addition to, or inconsistent with those stated herein, proposed by Buyer in any acceptance of an offer by Seller, are hereby objected to. No such additional, different or inconsistent terms and conditions shall become part of the contract between Buyer and Seller unless expressly accepted in writing by Seller. Seller's acceptance of any offer to purchase by Buyer is expressly conditional upon Buyer's assent to all the terms and conditions stated herein, including any terms in addition to, or inconsistent with those contained in Buyer's offer. Acceptance of Seller's products shall in all events constitute such assent.

**2. Payment:** Payment shall be made by Buyer net 30 days from the date of delivery of the items purchased hereunder. Amounts not timely paid shall bear interest at the maximum rate permitted by law for each month or portion thereof that the Buyer is late in making payment. Any claims by Buyer for omissions or shortages in a shipment shall be waived unless Seller receives notice thereof within 30 days after Buyer's receipt of the shipment.

**3. Delivery:** Unless otherwise provided on the face hereof, delivery shall be made F.O.B. Seller's plant. Regardless of the method of delivery, however, risk of loss shall pass to Buyer upon Seller's delivery to a carrier. Any delivery dates shown are approximate only and Seller shall have no liability for any delays in delivery.

**4. Warranty:** Seller warrants that the items sold hereunder shall be free from defects in material or workmanship for a period of 18 months from date of shipment from the Company. **THIS WARRANTY COMPRISES THE SOLE AND ENTIRE WARRANTY PERTAINING TO ITEMS PROVIDED HEREUNDER. SELLER MAKES NO OTHER WARRANTY, GUARANTEE, OR REPRESENTATION OF ANY KIND WHATSOEVER. ALL OTHER WARRANTIES, INCLUDING BUT NOT LIMITED TO, MERCHANTABILITY AND FITNESS FOR PURPOSE, WHETHER EXPRESS, IMPLIED, OR ARISING BY OPERATION OF LAW, TRADE USAGE, OR COURSE OF DEALING ARE HEREBY DISCLAIMED.**

**NOTWITHSTANDING THE FOREGOING, THERE ARE NO WARRANTIES WHATSOEVER ON ITEMS BUILT OR ACQUIRED WHOLLY OR PARTIALLY, TO BUYER'S DESIGN OR SPECIFICATIONS.**

**5. Limitation of Remedy: SELLER'S LIABILITY ARISING FROM OR IN ANY WAY CONNECTED WITH THE ITEMS SOLD OR THIS CONTRACT SHALL BE LIMITED EXCLUSIVELY TO REPAIR OR REPLACEMENT OF THE ITEMS SOLD OR REFUND OF THE PURCHASE PRICE PAID BY BUYER, AT SELLER'S SOLE OPTION. IN NO EVENT SHALL SELLER BE LIABLE FOR ANY INCIDENTAL, CONSEQUENTIAL OR SPECIAL DAMAGES OF ANY KIND OR NATURE WHATSOEVER, INCLUDING BUT NOT LIMITED TO LOST PROFITS ARISING FROM OR IN ANY WAY CONNECTED WITH THIS AGREEMENT OR ITEMS SOLD HEREUNDER, WHETHER ALLEGED TO ARISE FROM BREACH OF CONTRACT, EXPRESS OR IMPLIED WARRANTY, OR IN TORT, INCLUDING WITHOUT LIMITATION, NEGLIGENCE, FAILURE TO WARN OR STRICT LIABILITY.**

**6. Changes, Reschedules and Cancellations:** Buyer may request to modify the designs or specifications for the items sold hereunder as well as the quantities and delivery dates thereof, or may request to cancel all or part of this order, however, no such requested modification or cancellation shall become part of the contract between Buyer and Seller unless accepted by Seller in a written amendment to this Agreement. Acceptance of any such requested modification or cancellation shall be at Seller's discretion, and shall be upon such terms and conditions as Seller may require.

**7. Special Tooling:** A tooling charge may be imposed for any special tooling, including without limitations, dies, fixtures, molds and patterns, acquired to manufacture items sold pursuant to this contract. Such special tooling shall be and remain Seller's property notwithstanding payment of any charges by Buyer. In no event will Buyer acquire any interest in apparatus belonging to Seller which is utilized in the manufacture of the items sold hereunder, even if such apparatus has been specially converted or adapted for such manufacture and notwithstanding any charges paid by Buyer. Unless otherwise agreed, Seller shall have the right to alter, discard or otherwise dispose of any special tooling or other property in its sole discretion at any time.

**8. Buyer's Property:** Any designs, tools, patterns, materials, drawings, confidential information or equipment furnished by Buyer, or any other items which become Buyer's property, may be considered obsolete and may be destroyed by Seller after two (2) consecutive years have elapsed without Buyer placing an order for the items which are manufactured using such property. Seller shall not be responsible for any loss or damage to such property while it is in Seller's possession or control.

**9. Taxes:** Unless otherwise indicated on the face hereof, all prices and charges are exclusive of excise, sales, use, property, occupational or like taxes which may be imposed by any taxing authority upon the manufacture, sale or delivery of the items sold hereunder. If any such taxes must be paid by Seller or if Seller is liable for the collection of such tax, the amount thereof shall be in addition to the amounts for the items sold. Buyer agrees to pay all such taxes or to reimburse Seller therefore upon receipt of its invoice. If Buyer claims exemption from any sales, use or other tax imposed by any taxing authority, Buyer shall save Seller harmless from and against any such tax, together with any interest or penalties thereon which may be assessed if the items are held to be taxable.

**10. Indemnity For Infringement of Intellectual Property Rights:** Seller shall have no liability for infringement of any patents, trademarks, copyrights, trade dress, trade secrets or similar rights except as provided in this Part 10. Seller will defend and indemnify Buyer against allegations of infringement of U.S. patents, U.S. trademarks, copyrights, trade dress and trade secrets (hereinafter "Intellectual Property Rights"). Seller will defend at its expense and will pay the cost of any settlement or damages awarded in an action brought against Buyer based on an allegation that an item sold pursuant to this contract infringes the Intellectual Property Rights of a third party. Seller's obligation to defend and indemnify Buyer is contingent on Buyer notifying Seller within ten (10) days after Buyer becomes aware of such allegations of infringement, and Seller having sole control over the defense of any allegations or actions including all negotiations for settlement or compromise. If an item sold hereunder is subject to a claim that it infringes the Intellectual Property Rights of a third party, Seller may, at its sole expense and option, procure for Buyer the right to continue using said item, replace or modify said item so as to make it noninfringing, or offer to accept return of said item and return the purchase price less a reasonable allowance for depreciation. Notwithstanding the foregoing, Seller shall have no liability for claims of infringement based on information provided by Buyer, or directed to items delivered hereunder for which the designs are specified in whole or part by Buyer, or infringements resulting from the modification, combination or use in a system of any item sold hereunder. The foregoing provisions of this Part 10 shall constitute Seller's sole and exclusive liability and Buyer's sole and exclusive remedy for infringement of Intellectual Property Rights.

If a claim is based on information provided by Buyer or if the design for an item delivered hereunder is specified in whole or in part by Buyer, Buyer shall defend and indemnify Seller for all costs, expenses or judgments resulting from any claim that such item infringes any patent, trademark, copyright, trade dress, trade secret or any similar right.

**11. Force Majeure:** Seller does not assume the risk of and shall not be liable for delay or failure to perform any of Seller's obligations by reason of circumstances beyond the reasonable control of Seller (hereinafter "Events of Force Majeure"). Events of Force Majeure shall include without limitation, accidents, acts of God, strikes or labor disputes, acts, laws, rules or regulations of any government or government agency, fires, floods, delays or failures in delivery of carriers or suppliers, shortages of materials and any other cause beyond Seller's control.

**12. Entire Agreement/Governing Law:** The terms and conditions set forth herein, together with any amendments, modifications and any different terms or conditions expressly accepted by Seller in writing, shall constitute the entire Agreement concerning the items sold, and there are no oral or other representations or agreements which pertain thereto. This Agreement shall be governed in all respects by the law of the State of Ohio. No actions arising out of sale of the items sold hereunder or this Agreement may be brought by either party more than two (2) years after the cause of action accrues.

Printed in U.S.A.

**ATLAS  
CYLINDERS**

Parker Hannifin Corporation  
**Atlas Cylinders**  
500 South Wolf Road  
Des Plaines, IL 60016 USA  
phone (847) 298-2400  
fax (800) 892-1008  
[www.atlascylinders.com](http://www.atlascylinders.com)

Parker Hannifin Corporation  
Motion and Control Division  
160 Chisholm Drive  
Milton, ON Canada L9T 3G9  
direct (905) 693-3000  
fax (905) 876-1958  
[www.parker.com](http://www.parker.com)