

# AES/F & ABS/F Series

## Flange Head X Flat-Face

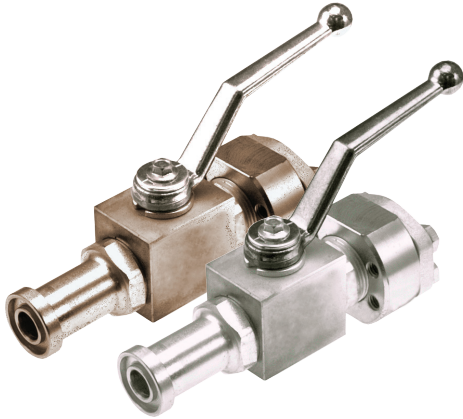

- Flange Head X Flat-Face connections for insertion in between existing flange joints
- Ideal for flange mounting anywhere a flange connection exists or where hoses are already connected
- Carbon Steel with Zinc Chromate Plating (RoHS Compliant)
- 316 stainless steel available
- POM seats & Buna O-rings standard on carbon steel valves
- Optional seal materials available for extreme temperature applications & fluid compatibility (Consult Factory)

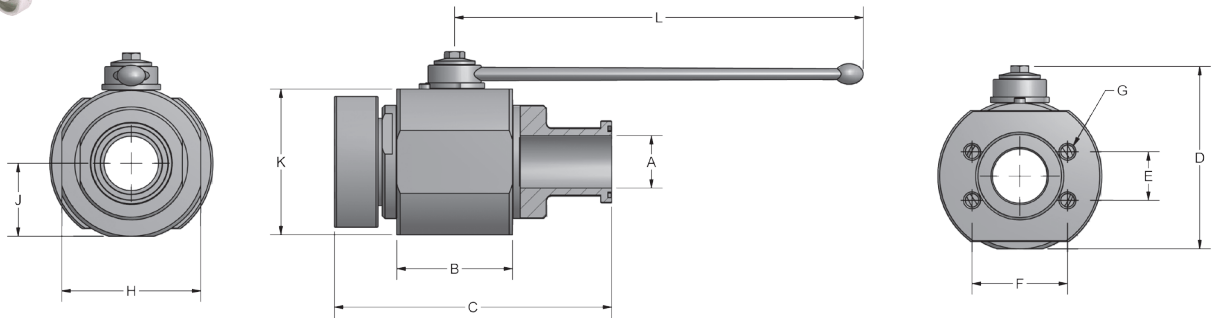

Standard handles supplied are: #8 C1010ZB  
 #12 - #16 C1200ZB  
 Refer to page 43 for details. #20 - #32 C92501Z-SW17

AES/F SERIES												
SERIES	PSI MAX	A BORE	B	C	D	E	F	G UNC-2B	H	J	K	L
AES/F3#8	5000	.51	1.91	5.3	2.24	.69	1.50	5/16-18	1.46	.71	1.69	4.33
AES/F6#8	6000	.51	1.91	5.3	2.24	.72	1.59	5/16-18	1.46	.71	1.69	4.33
AES/F3#12	5000	.79	2.46	5.8	2.89	.87	1.87	3/8-16	1.77	.92	2.17	7.09
AES/F6#12	6000	.79	2.46	6.1	2.89	.94	2.00	3/8-16	1.77	.92	2.17	7.09
AES/F3#16	5000	.98	2.62	6.4	3.29	1.03	2.06	3/8-16	2.17	1.16	2.56	7.09
AES/F6#16	5000	.98	2.62	6.8	3.29	1.09	2.25	7/16-14	2.17	1.16	2.56	7.09

ABS/F SERIES												
SERIES	PSI MAX	A BORE	B	C	D	E	F	G UNC-2B	H	J	K	L
ABS/F3#20	4000	1.26	2.96	7.2	4.39	1.19	2.31	7/16-14	2.36	1.83	3.66	11.81
ABS/F6#20	5000	1.26	2.96	7.8	4.39	1.25	2.63	1/2-13	2.36	1.83	3.66	11.81
ABS/F3#24	3000	1.57	3.36	8.0	4.94	1.41	2.75	1/2-13	2.95	2.11	4.21	11.81
ABS/F6#24	5000	1.57	3.36	9.0	4.94	1.44	3.13	5/8-11	2.95	2.11	4.21	11.81
ABS/F3#32	3000	1.97	3.86	8.4	5.22	1.69	3.06	1/2-13	3.35	2.24	4.49	11.81
ABS/F6#32	5000	1.97	3.86	9.5	5.22	1.75	3.81	3/4-10	3.35	2.24	4.49	11.81



# AES/F & ABS/F Series

## Flange Head X Flat-Face

### Model Code Breakdown

AES/F3 #8 - 1 1 D B \_

**VALVE SERIES**

AES/F3	Code 61 Block Body
AES/F6	Code 62 Block Body
ABS/F3	Code 61 Round Body
ABS/F6	Code 62 Round Body

**CONNECTION SIZE**

**BODY & ADAPTER MATERIAL**

1	Carbon Steel
2	316 Stainless Steel

**BALL & STEM MATERIAL**

1	Carbon Steel
2	316 Stainless Steel

**LOCKING KIT OR  
OPTIONAL HANDLE CODE**  
(See pages 42 & 43)

**ADAPTER & STEM SEALS**

B	Buna- Standard
V	Viton (Std on S/S)

**BALL & STEM SEATS**

D	POM- Standard
P	PEEK
N	PA612

Please consult your system's seal manufacturer for recommendation of seal selection, as Anchor Fluid Power does not accept responsibility for seal selection.

**MAXIMUM & MINIMUM WORKING TEMPERATURES FOR SEAL MATERIALS**

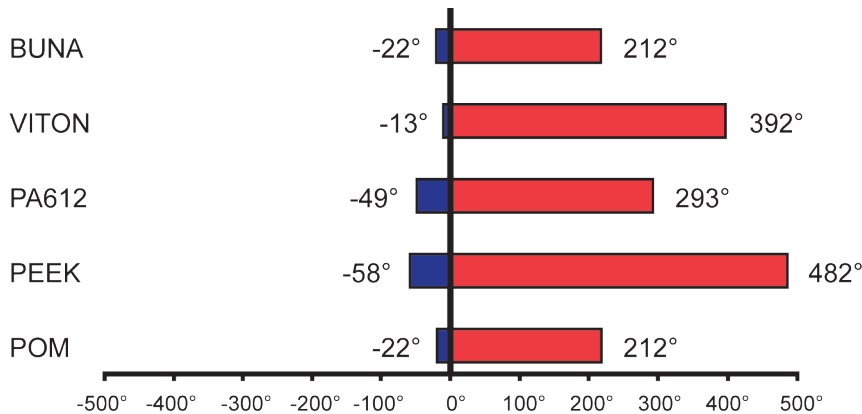

All temperatures are in degrees Fahrenheit.