

Oilgear

PVWW Open Loop Pumps For Fluids Containing Water



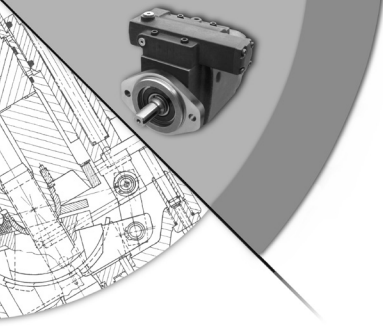

Table of Contents

Performance Assurance	page 3
Features and Benefits	4
Specifications	5-6
Dimensions and Weights	7-8
Typical Port Locations	9
Controls	
Pressure Compensator	10
Dual Pressure Compensator	10
Soft Start Pressure Compensator	10
Volume Pressure Sensing (Load Sense)	11
Horsepower Limiter	12
Manual Controls	12
Line Mount Remote Pressure Control	13
Performance Data	
Efficiency, Delivery, Horsepower	14-15
Sound	16-17
Inlet	18-19
Ordering Information	20
Supporting Documents	21

PERFORMANCE ASSURANCE – STANDARD WITH EVERY OILGEAR PUMP



Oilgear
PERFORMANCE
ASSURANCE

Every Oilgear product is shipped to you with our Performance Assurance — a corporate commitment to stay with your installation until our equipment performs as specified.

Hydraulic equipment and systems have been Oilgear's primary business since 1921. For decades, we have developed hydraulic techniques to meet the unique needs and unusual fluid power problems of machinery builders and users worldwide, matching fluid power systems to a tremendous range of applications and industries. Our exclusive Performance Assurance program is built upon that strong foundation.

As a customer, you also benefit from access to Oilgear's impressive technical support network. You'll find factory trained and field-experienced application engineers on staff at every Oilgear facility. They are backed by headquarters staff who can access the records and knowledge learned from decades of solving the most difficult hydraulic challenges.

When your design or purchase is complete, our service is just beginning. If you ever need us, our Oilgear engineers will be there, ready to help you with the education, field service, parts and repairs to assure that your installation runs smoothly — and keeps right on running.

Oilgear Performance Assurance

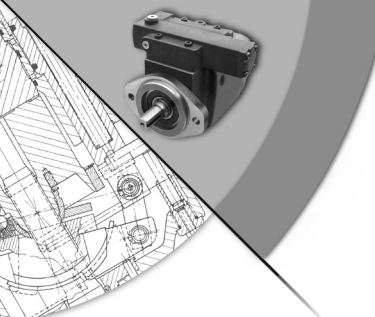

PVWW Open Loop Pumps

Oilgear Features and Benefits

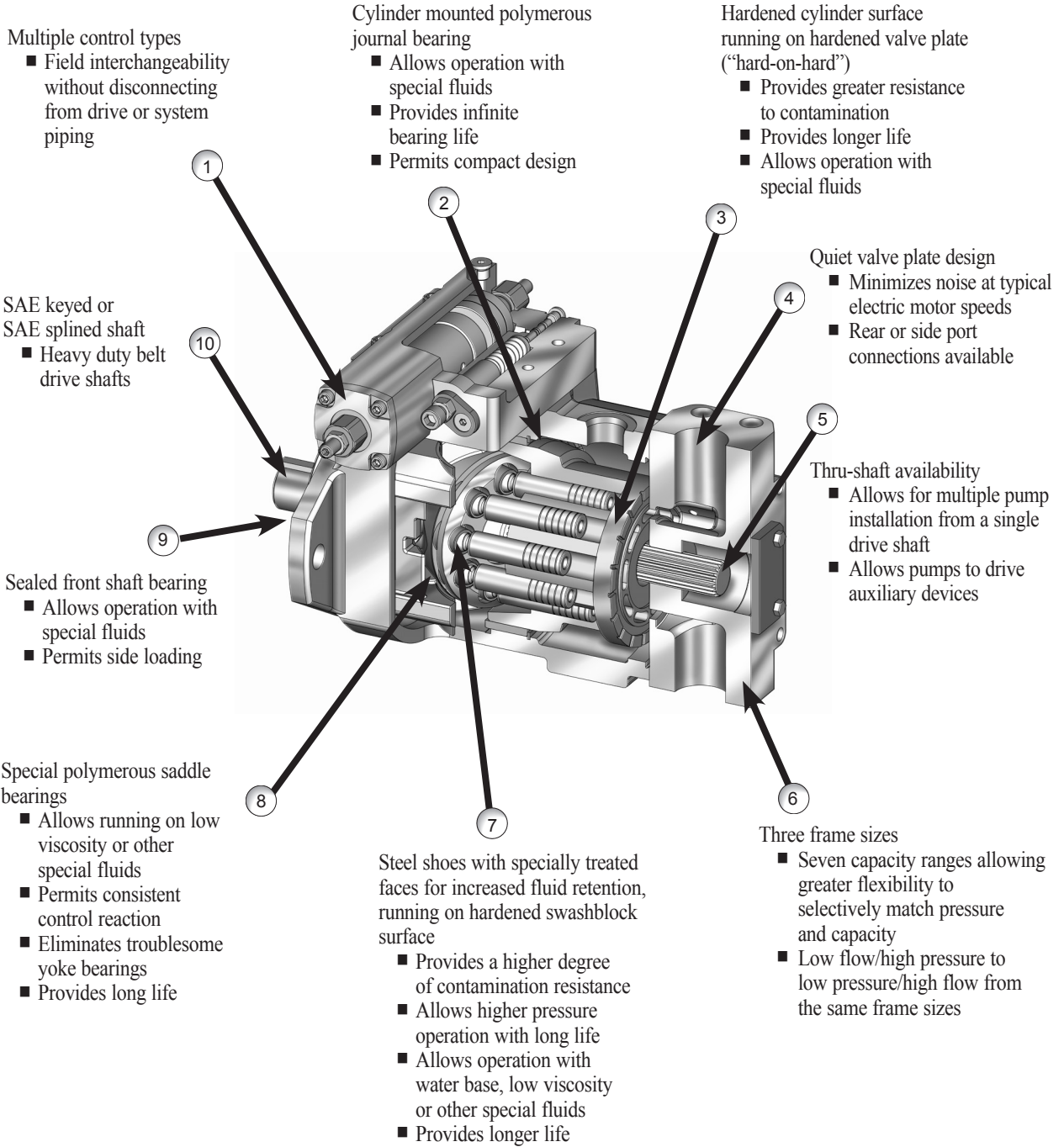

SPECIFICATIONS

SINGLE PUMP

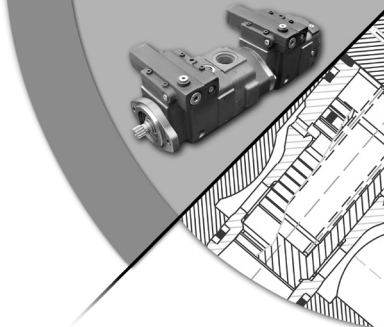

Based on 27 – 30 ssu viscosity fluid

FRAME SIZE	UNIT SIZE	THEORETICAL MAXIMUM DISPLACEMENT		RATED CONTINUOUS PRESSURE*		PEAK PRESSURE*		FLOW RATE at 1800 rpm, rated continuous pres. & 14.7 psia (1.0 bar) inlet condition		MINIMUM INLET PRESSURE psia (bar)			MAXIMUM SPEED rpm	POWER INPUT at rated cont. pres. & 1800 rpm	
		in ³ /rev	ml/rev	psi	bar	psi	bar	gpm	l/min	1200rpm	1500rpm	1800rpm		hp	kw
A	014	0.86	14,1	3000	205	3500	240	5.5	20,8	5.5 (.38)	5.9 (.41)	6.4 (.44)	1800	12.9	9,6
	022	1.35	22,1	2000	135	2500	175	9.0	34,1	5.5 (.38)	6.0 (.41)	7.0 (.48)	1800	13.3	9,9
B	034	2.06	33,8	3000	205	3500	240	12.7	48,1	7.0 (.48)	7.6 (.52)	8.4 (.58)	1800	30.4	22,7
	046	2.83	46,4	2000	135	2500	175	20.3	76,9	7.2 (.50)	7.9 (.54)	9.0 (.62)	1800	27.8	20,7
C	076	4.67	76,5	3000	205	3500	240	32.6	123,6	8.0 (.55)	8.6 (.59)	9.6 (.66)	1800	68.4	51,0
	098	6.00	98,3	2000	135	2500	175	42.8	162,2	7.6 (.52)	8.6 (.59)	9.8 (.68)	1800	59.7	44,5
	130	7.94	130,2	1200	85	1500	105	56.5	214,2	8.0 (.55)	9.3 (.64)	14.5 (1,00)	1800	51.1	38,1

Note: Minimum speed 600 rpm.

* Higher pressure available – consult factory.

These units are designed to run with fluids in the 27 to 2000 SSU range.

For units to be run with conventional (oil) hydraulic fluids, please refer to Oilgear Bulletin 47085 (PVWJ Pumps)

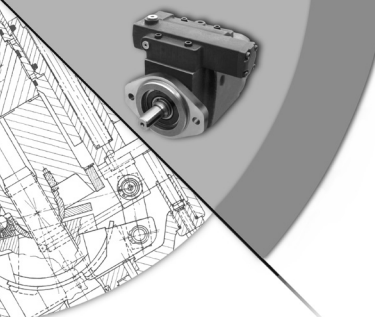

PUMP COMBINATIONS

Two or more Oilgear axial piston variable delivery pumps can be integrally coupled together and driven from a single shaft.

Pump deliveries can be combined for large volume circuits or deliveries can be used individually. See page 5 for individual pump ratings.

The front pump can be used at full rated output while the rear pumps are governed by the thru-shaft torque listed in the table below.

THRU-SHAFT SIZING/COMPATIBILITY

PISTON PUMP FRAME SIZE	PUMP SIZE	INPUT TORQUE								ALLOWABLE THRU- SHAFT TORQUE	
		RATED PRESSURE		INPUT TORQUE (T _R) @ RATED PRESSURE		PEAK PRESSURE		INPUT TORQUE @ PEAK PRESSURE			
		psi	bar	in-lb	Nm	psi	bar	in-lb	Nm	in-lb	Nm
A	014	3000	205	452	51,0	3500	240	527.3	59,5	1290	145,1
	022	2000	135	466	52,6	2500	175	582.5	65,8		
B	034	3000	205	1064	120,2	3500	240	1241.3	140,2	2250	253,1
	046	2000	135	973	110,0	2500	175	1216.3	137,4		
C	076	3000	205	2395	270,6	3500	240	2794.2	315,7	6400	720,0
	098	2000	135	2090	236,1	2500	175	2612.5	295,2		
	130	1200	85	1790	202,2	1500	105	2236.3	252,7		

ACTUAL INPUT TORQUE CALCULATION

$$T_A = T_R \times \left(\frac{\text{ACTUAL OPERATING PRESSURE}}{\text{RATED PRESSURE}} \right) \times \left(\frac{\% \text{ FULL DELIVERY}}{100\%} \right)$$

NOTE: Total input torque to the front unit may not exceed the values given in the table. The torque may be divided between the units in any fashion as long as the total does not exceed the table value.

SINGLE PUMP

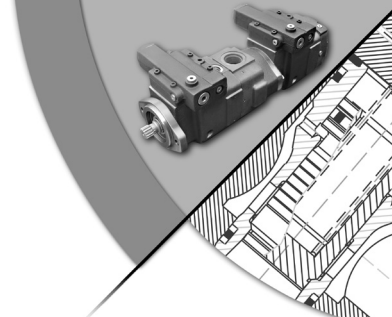

All Pumps

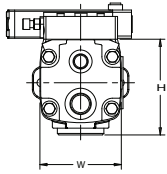

Single Pump
w/Rear Ports

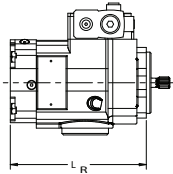

Single Pump w/Side Ports
w/wo Thru-shaft

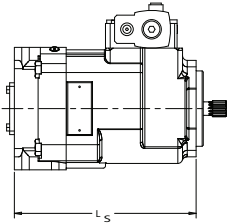

Single Pump w/Side Ports
w/Thru-shaft & w/Adapter

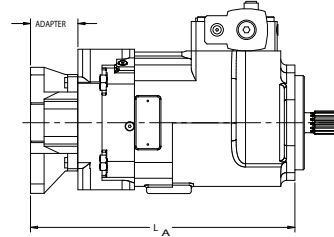

DIMENSIONS and WEIGHTS W/O CONTROLS

FRAME SIZE	PVWW PUMP SIZE	HEIGHT		WIDTH		LENGTH						WEIGHT	
		H		W		L _R		L _S		L _A		SINGLE PUMP W/REAR PORTS	
		inch	mm	inch	mm	inch	mm	inch	mm	inch	mm	lb	kg
A	014, 022	4.50	114,3	4.32	109,7	7.20	182,9	9.62	244,3	10.94	277,9	32	14,5
B	034, 046	6.11	155,2	5.80	147,3	8.50	215,9	9.63	244,6	12.36	313,9	68	30,9
C	076, 098, 130	7.18	182,4	6.76	171,7	10.44	265,2	11.50	292,1	14.00	355,6	103	46,8

See appropriate data sheet for further details.

All dimensions are approximate. For detailed dimensions, contact your Oilgear representative.

Length Example: SINGLE PUMP

* With rear ports

PVWW - 034 - A1UV - RSAY - P - 1NNNN

Size 034 (L_R) length = 8.50 inches (215,9 mm)

* With side ports, with or without thru-shaft

PVWW - 034 - A1UV - RDFY - P - 1NNNN

Size 034 (L_S) length = 9.63 inches (244,6 mm)

* With side ports, with thru-shaft adapter

PVWW - 034 - A1UV - RDFY - P - 1NNNN

Size 034 (L_A) length = 12.36 inches (313,9 mm)

Oilgear Dimensions and Weights

DUAL PUMP

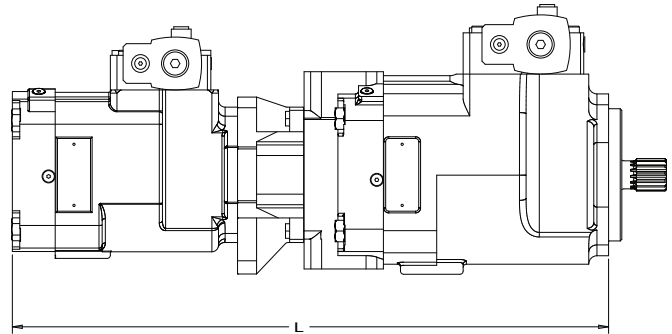
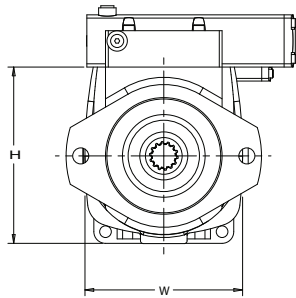

DIMENSIONS and WEIGHTS W/O CONTROLS

FRAME SIZE	PVWW DUAL PUMP SIZES	H HEIGHT		W WIDTH		L LENGTH		WEIGHT	
		inch	mm	inch	mm	inch	mm	lb	kg
A/A	014 or 022 & 014 or 022	4.50	114,3	4.32	109,7	18.12	460,2	72	33
B/A	034 or 046 & 014 or 022	6.11	155,2	5.80	147,3	19.56	496,8	108	49
B/B	034 or 046 & 034 or 046	6.11	155,2	5.80	147,3	20.86	529,8	144	66
C/A	076, 098 or 130 & 014 or 022	7.18	182,4	6.76	171,7	21.20	538,5	143	65
C/B	076, 098 or 130 & 034 or 046	7.18	182,4	6.76	171,7	22.50	571,5	179	82
C/C	076, 098 or 130 & 076, 098 or 130	7.18	182,4	6.76	171,7	24.44	620,8	214	97

Length dimensions are for a rear ported dual pump. For further dimensions of these or other multiple combinations including other types of auxiliary pumps, contact your Oilgear representative.

Length Example:

DUAL PUMP

Two Variable Delivery Pumps

PVWW-098-A1UV-LDFS-P-1NNSN-AN/PVWW-046-LSAS-P-1NNSN

Size 098 pump (L_A) length = 14 inches (355,6 mm) plus

Size 046 pump (L_R) length = 8.5 inches (215,9 mm) = 22.50 inches (571,5 mm)

TRIPLE PUMP

Three Variable Delivery Pumps

PVWW-098-A1UV-LDFS-P-1NNSN-BN/PVWW-046-A1UV-LDFS-P-1NNSN-AN/

PVWW-022-A1UV-LDAS-P-1NNSN-CP

Size 098 pump (L_A) length = 14 inches (355,6 mm) plus

Size 046 pump (L_A) length = 12.36 inches (313,9 mm) plus

Size 022 pump (L_S) length = 9.62 inches (244,3 mm) = 35.98 inches (913,9 mm)

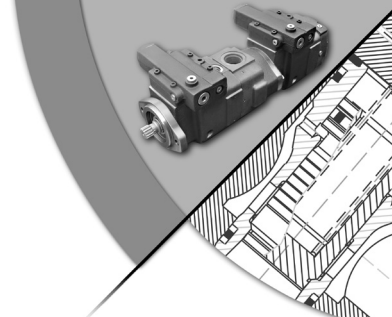

Oilgear Typical Port Locations

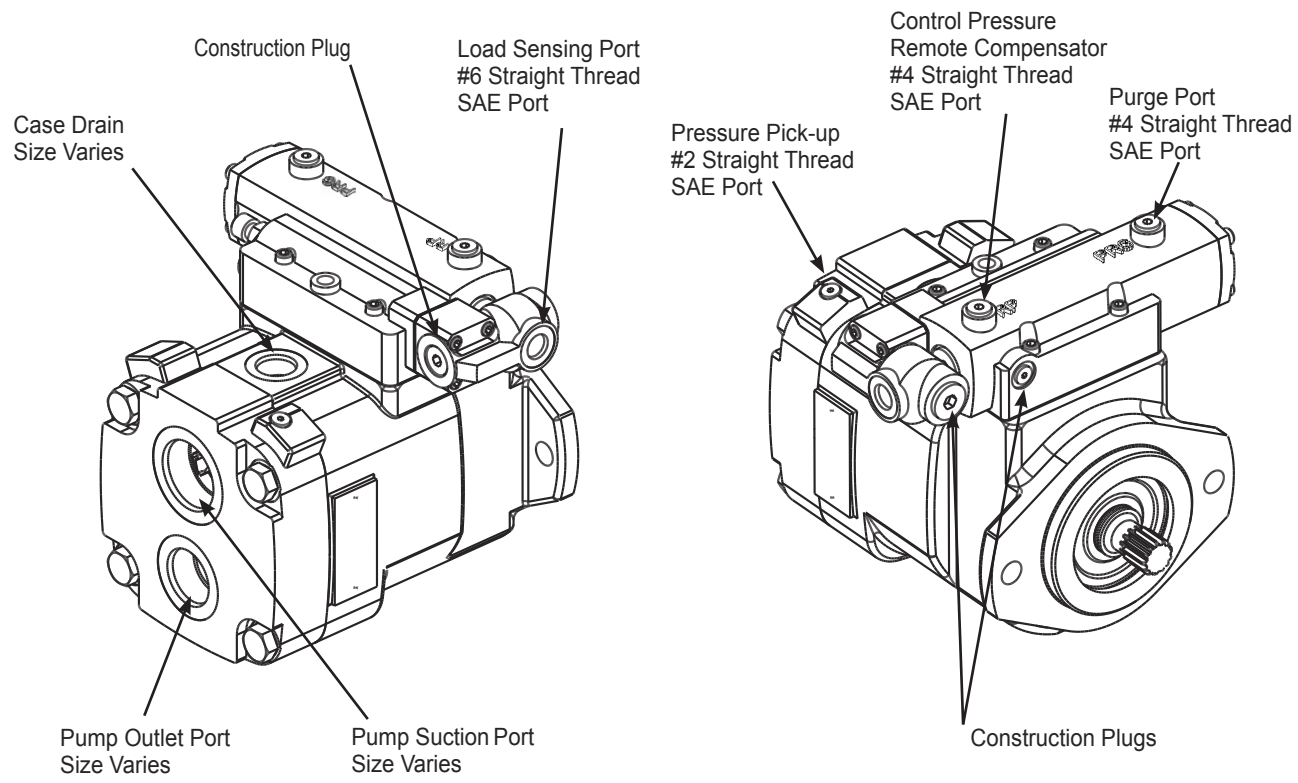

NOTE: Pump shown in illustration above is a PVWW B frame with fixed load sense control (P-1NN/F), RH (CW) rotation. Port size and/or location can vary with different pump size or configuration. Refer to the proper installation drawings for your specific pump . A listing of standard installation drawings can be found on page 21.

Pump Controls

PRESSURE*

■ Pressure Compensator

Ensures maximum pump flow until unit reaches preset control pressure setting then regulates output flow to match the requirements of the system while maintaining preset output pressure. Can be adjusted from 750 psi (52 bar) working pressure up to the maximum pressure rating of the applicable pump. **"P-LNN"** control provides a lower minimum pressure. Can be adjusted from 250 psi (17 bar) working pressure up to a maximum of 1500 psi (105 bar).

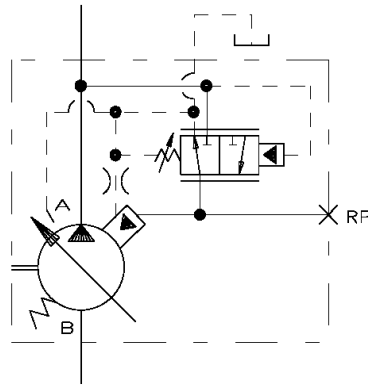

"P-1NN" "P-LNN"

■ Dual Pressure Compensator

Works the same as the "P-1NN" control except it provides two independently adjustable pressure compensated settings as selected by an integral solenoid.

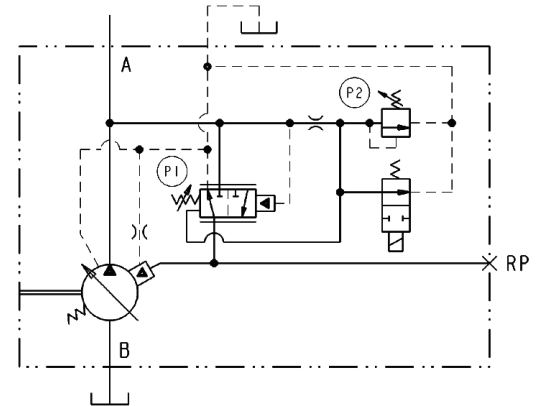

"P-2NN"

■ Soft Start Pressure Compensator

Pump starts "softly" by going quickly at low pressure to a reduced flow setting, thereby reducing start up torque requirements. The "P-KNN" control uses a normally closed cartridge that will unload the pump at the minimum pressure setting with the solenoid energized.

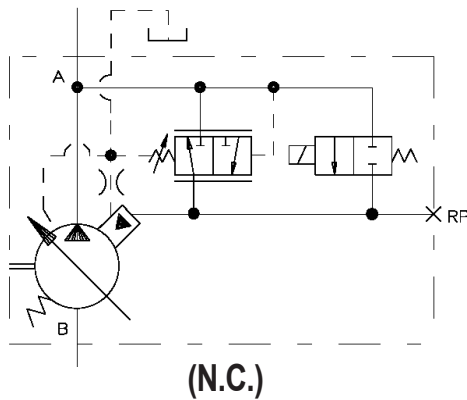

"P-KNN"

■ Soft Start Pressure Compensator

Pump starts "softly" by going quickly at low pressure to a reduced flow setting, thereby reducing start up torque requirement. The "P-CNN" control uses a normally open cartridge that will unload the pump at the minimum pressure setting with no power to the solenoid.

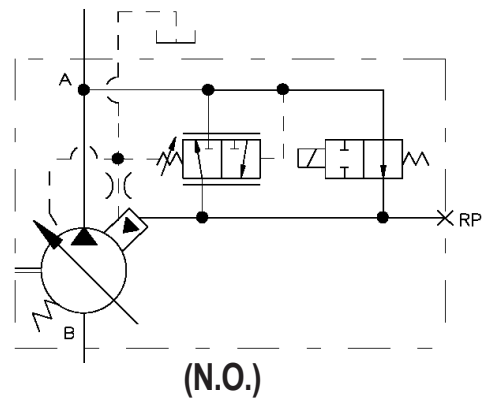

"P-CNN"

* Be sure system and pumps are protected against overloads with a high-pressure relief valve.

VOLUME PRESSURE SENSING*

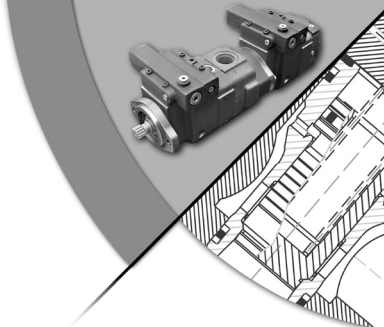

Fixed Load Sense w/Pressure Compensator

"P-1NN/F"

A constant flow output is maintained for a given flow control valve setting regardless of changes in drive speed and/or working pressure. The pressure compensator control overrides the load sense control when system pressure reaches the preset control pressure. Control pressure can be adjusted from 750 psi (52 bar) up to the maximum pressure rating of the applicable pump. Load sense differential is set at 170 PSID (11,7 bar). See page 13 for remote control options.

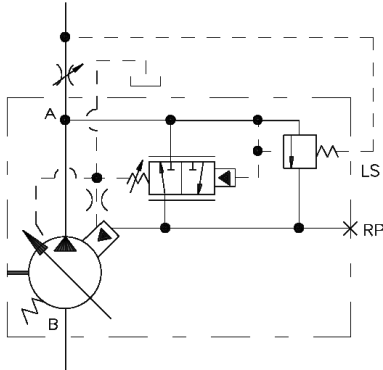

Fixed Load Sense w/Low Pressure Compensator

"P-LNN/F"

Works the same as the P-1NN/F control except it provides a lower minimum pressure. It can be adjusted from 250 psi (17 bar) working pressure up to a maximum of 1500 psi (105 bar). Load sense differential is set at 170 PSID (11,7 bar). See page 13 for remote control options.

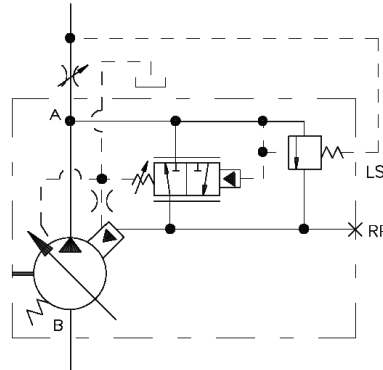

Adjustable Load Sense w/Pressure Compensator "P-1NN/J" & "P-1NN/K"

Same as the "P-1NN/F" and "P-LNN/F" controls except the load sense differential is externally adjustable. The adjustment range for the "P-1NN/J" control is 100 to 220 PSID (7 to 15 bar). The adjustment range for the "P-1NN/K" control is 225 to 350 PSID (15,5 to 24 bar).

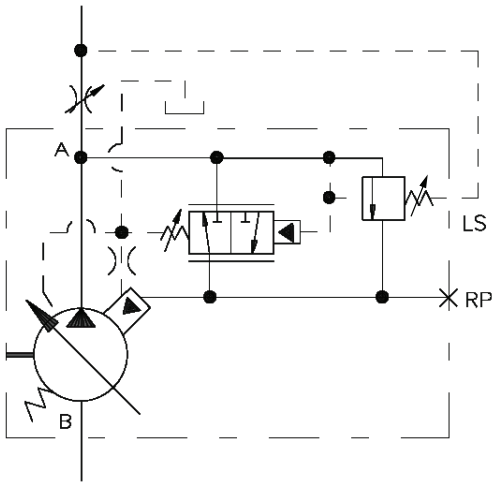

Oilgear Pump Controls

* Be sure system and pumps are protected against overloads with a high-pressure relief valve.

HORSEPOWER LIMITING*

Horsepower Limiter w/Pressure Compensator "P-1NN/H"

Automatically reduces delivery, as unit pressure rises, to limit horsepower consumption. The pressure compensator control over rides the horsepower control when system pressure reaches the preset control pressure. Control pressure can be adjusted from 750 psi (52 bar) up to the maximum pressure rating of the applicable pump.

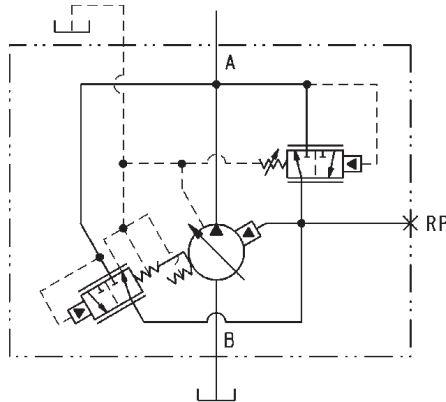

Horsepower Limiter "P-1NN/G," "P-1NN/C," & "P-1NN/D" w/Load Sense

A constant flow output is maintained for a given flow control valve setting regardless of changes in drive speed and/or working pressure until (limited) horsepower setting is reached. Control then automatically reduces delivery, as unit pressure rises, to limit horsepower consumption. **P-1/G** has fixed load sense differential set at 170 PSID (11,7 bar). **P-1/C** has variable load sense differential adjustable from 100-220 PSID (7 to 15 bar). **P-1/D** is variable with differential adjustable from 225-350 PSID (15,5 to 24 bar).

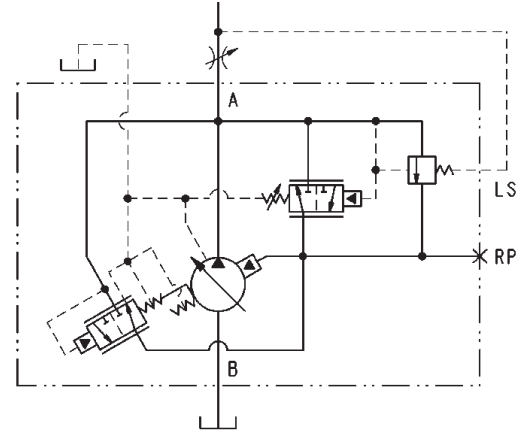

MANUAL*

Lever Operated "M-N"

Varies displacement proportional to the rotation of a pintle.

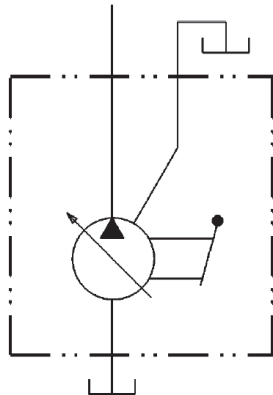

Lever Operated w/Neutral Bypass "M-S"

Varies displacement proportional to the rotation of a pintle which is equipped with a neutral bypass to prevent creep when centered.

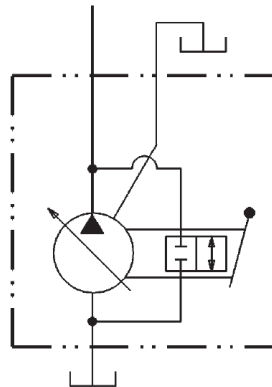

Handwheel "M-H"

Provides simple handwheel adjustment of delivery.

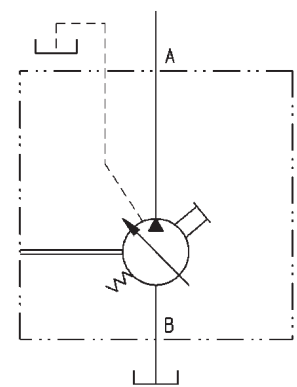

* Be sure system and pumps are protected against overloads with a high-pressure relief valve.

LINE MOUNTED REMOTE PRESSURE CONTROL FOR SINGLE & MULTIPLE PUMPS

Remote operation of pumps with load sense controls can be accomplished by installing a Remote Compensator Valve at the location shown in the control circuits.

SINGLE PUMP

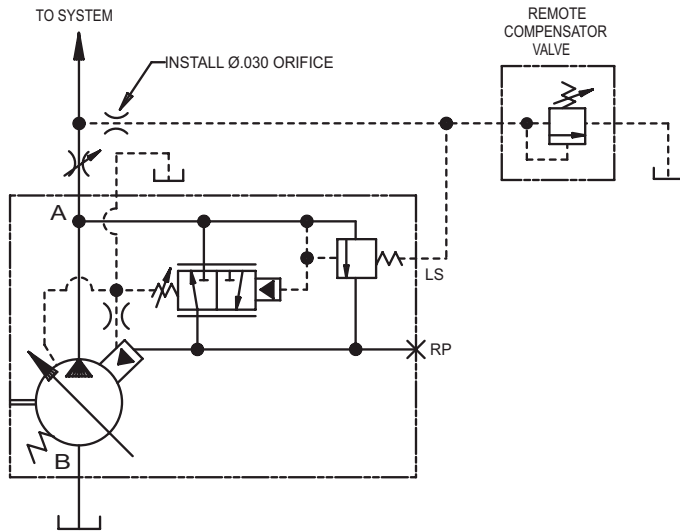

Refer to Data Sheet 47491

MULTIPLE PUMPS

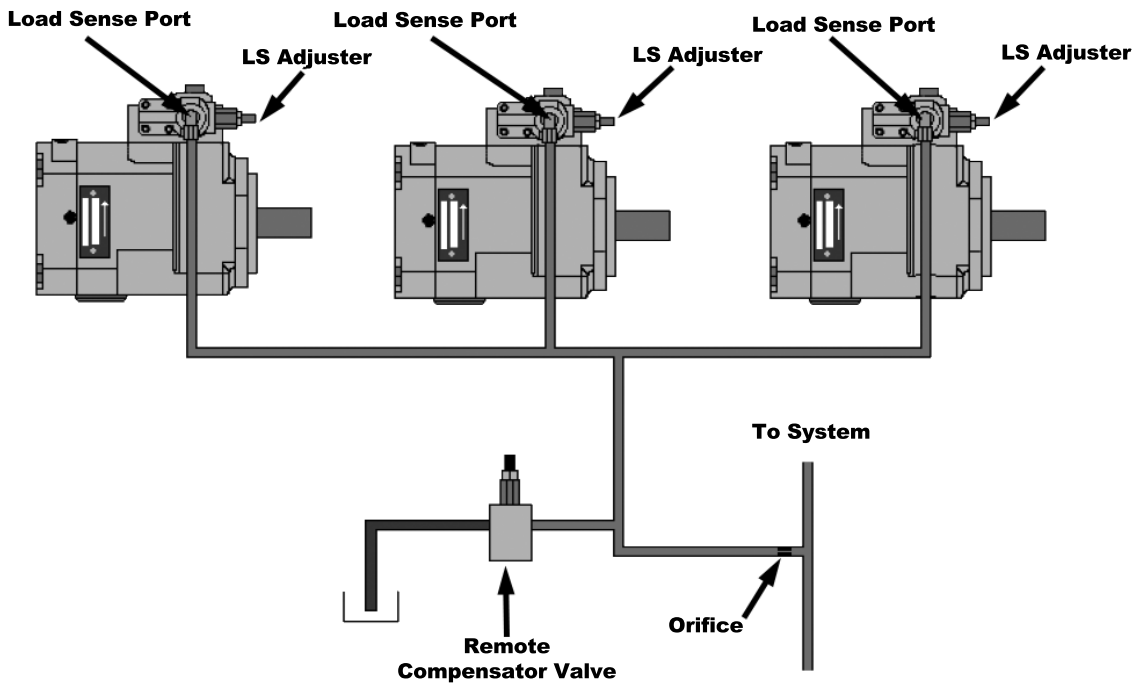

Refer to Data Sheet 47974

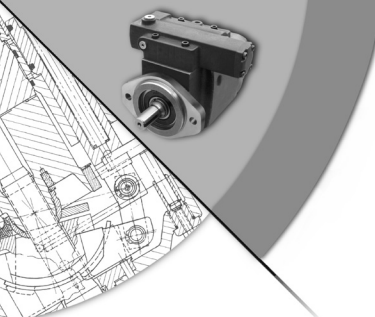

The following single pump curves are based on an oil temperature of 95° F (27 SSU) and 14.7 psia (1 bar_{abs}). Efficiency curves are based on pump running at 1800 rpm.

Frame Size A

■ PVWW-014

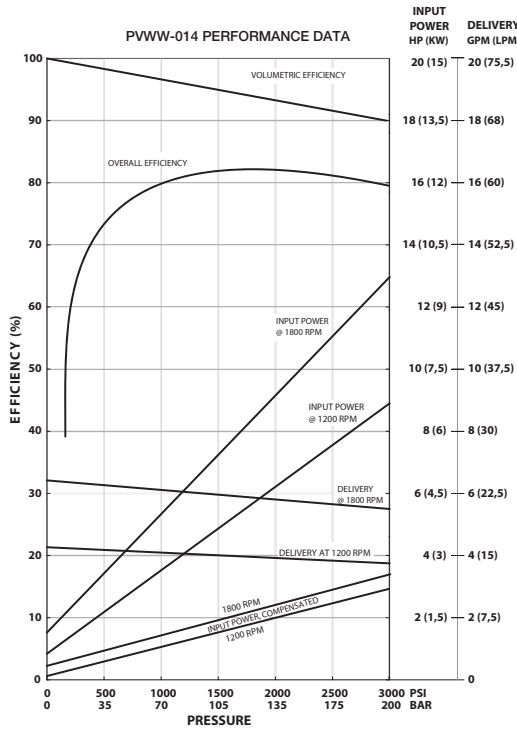

■ PVWW-022

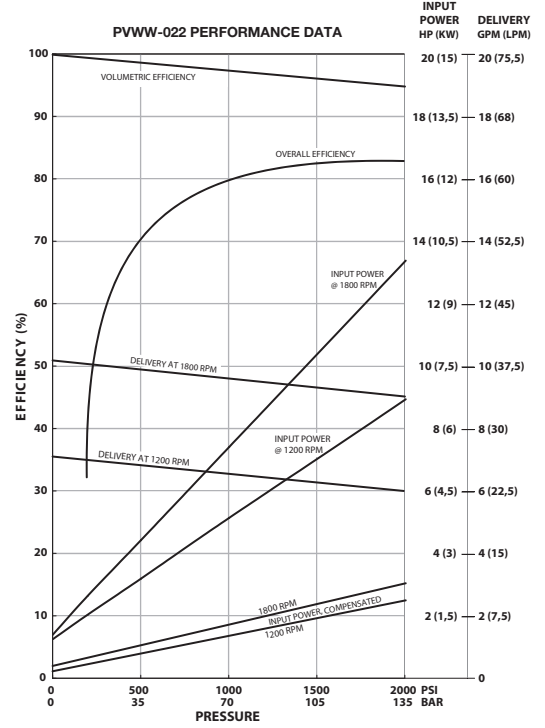

Frame Size B

■ PVWW-034

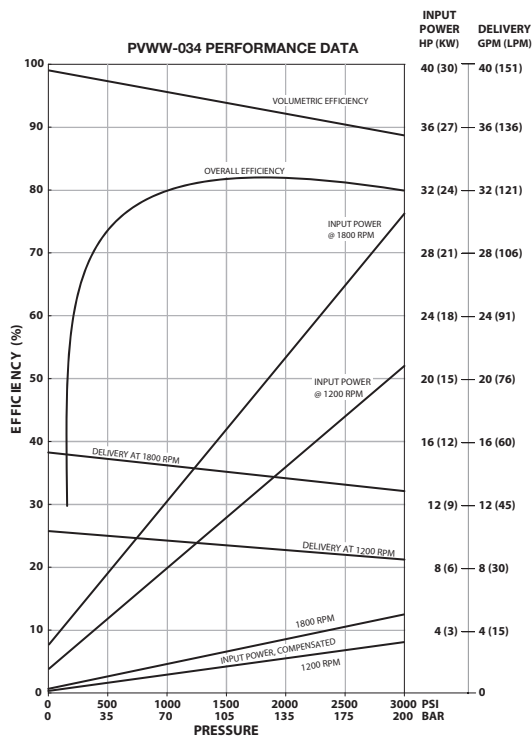

■ PVWW-046

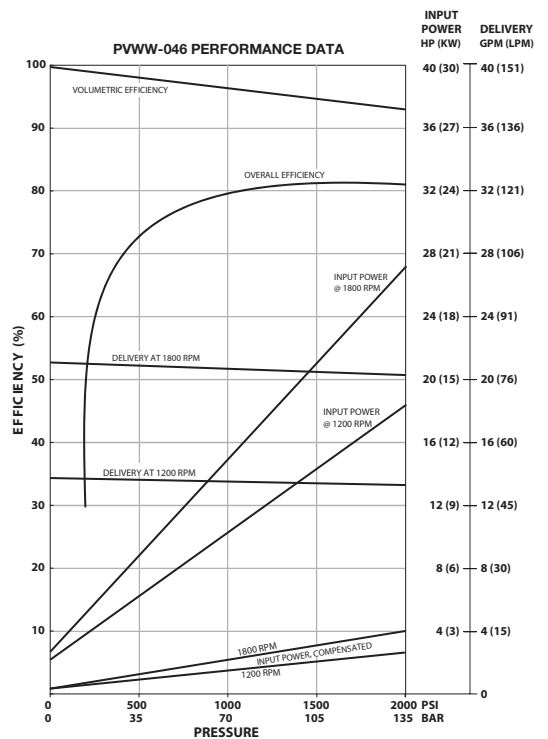

The following single pump curves are based on an oil temperature of 95° F (27 SSU) and 14.7 psia (1 bar_{abs}). Efficiency curves are based on pump running at 1800 rpm.

Frame Size C

PVWW-076

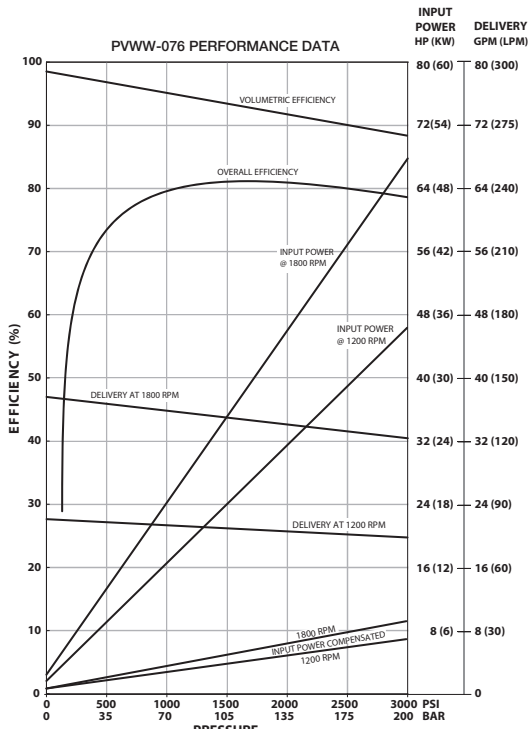

PVWW-098

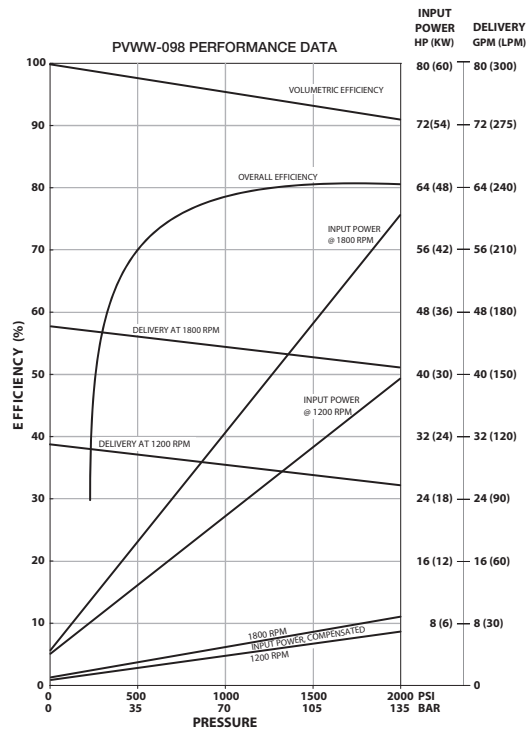

PVWW-130

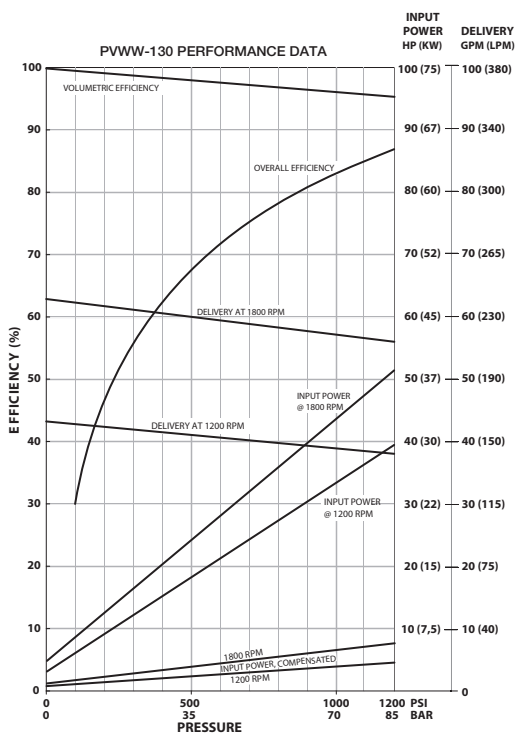

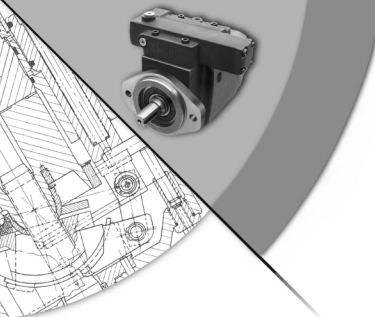

All of the following sound curves are based on the pump delivering full volume from port "A." Single microphone noise taken in semi-reverberant room at three feet from pump surface. Tolerance on curves is +3 dBA.

Frame Size A

■ PVWW-014 - FULL STROKE

PVWW-014 SOUND LEVEL

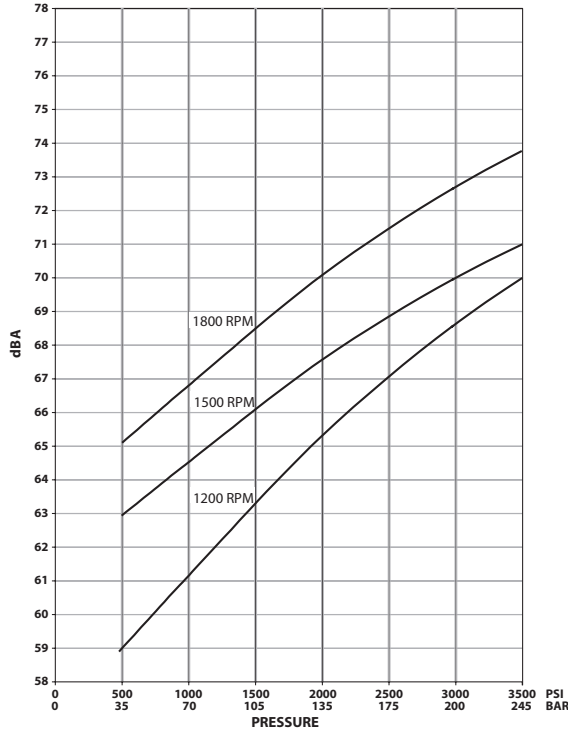

■ PVWW-022 - FULL STROKE

PVWW-022 SOUND LEVEL

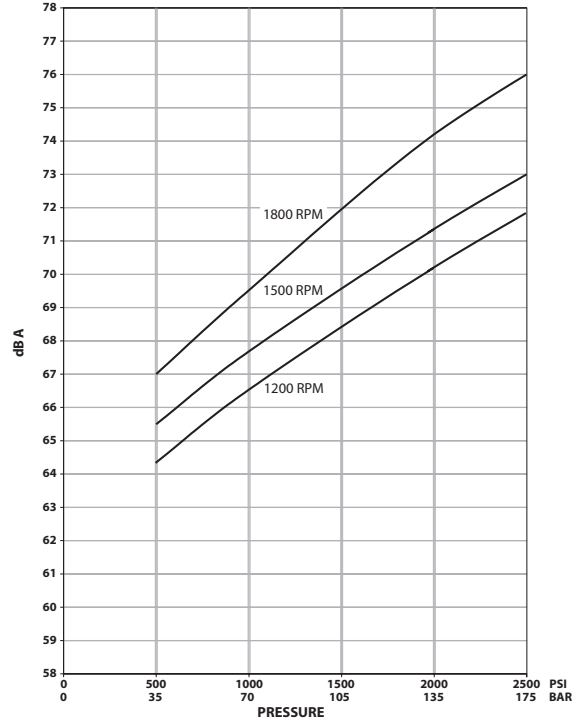

Frame Size B

■ PVWW-034 - FULL STROKE

PVWW-034 SOUND LEVEL

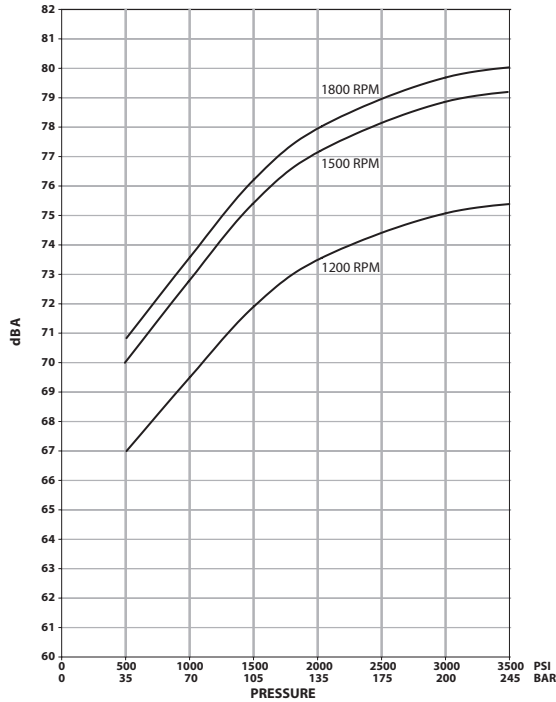

■ PVWW-046 - FULL STROKE

PVWW-046 SOUND LEVEL

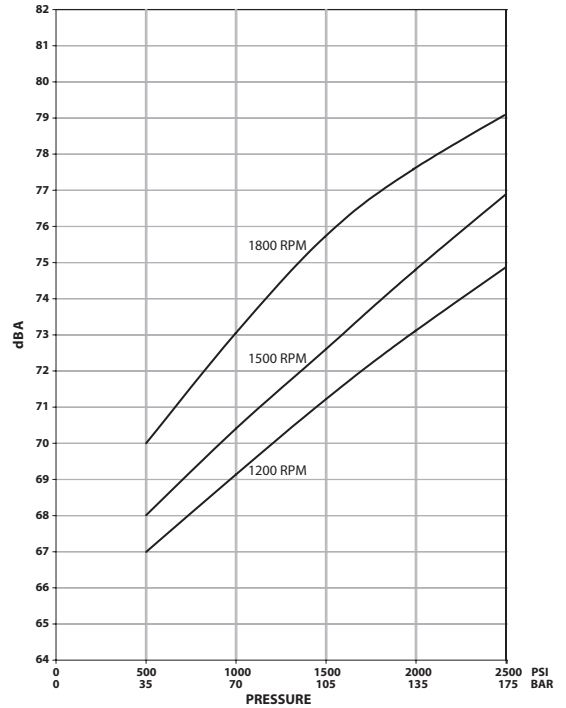

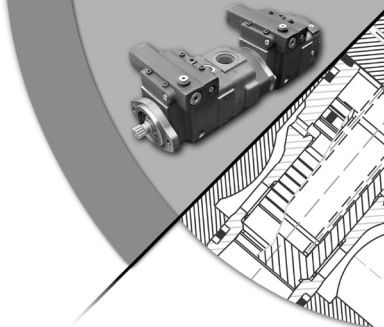

All of the following sound curves are based on the pump delivering full volume from port "A." Single microphone noise taken in semi-reverberant room at three feet from pump surface. Tolerance on curves is +3 dBA.

Frame Size C

PVWW-076 - FULL STROKE

PVWW-076 SOUND LEVEL

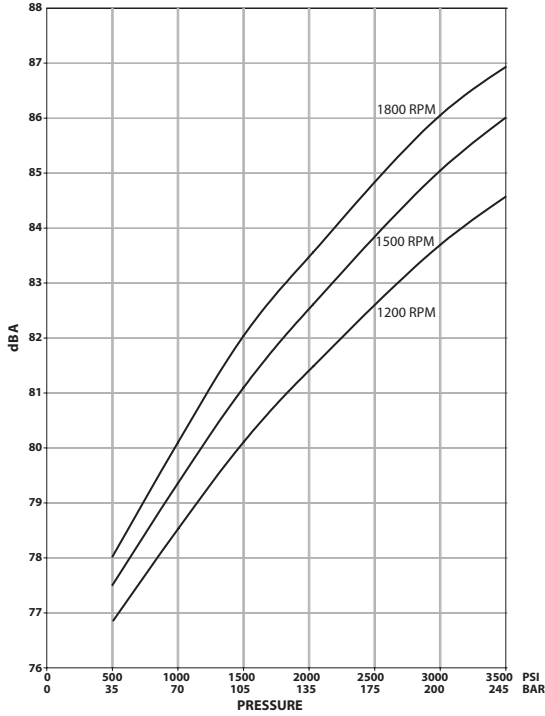

PVWW-098 - FULL STROKE

PVWW-098 SOUND LEVEL

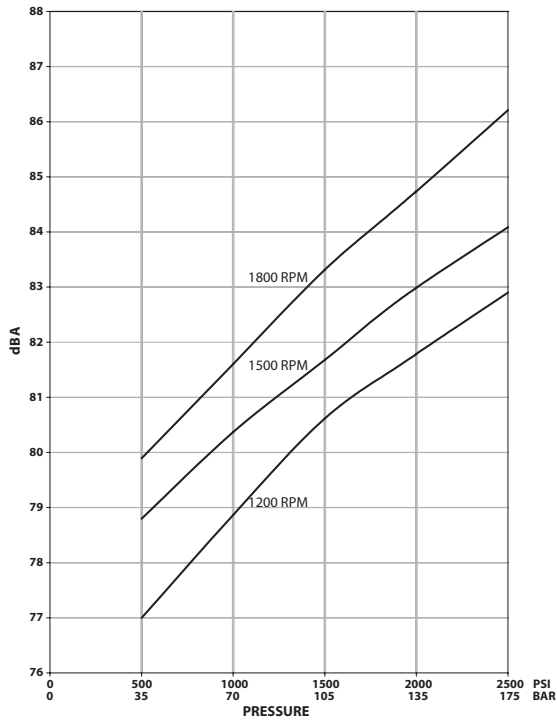

PVWW-130 - FULL STROKE

PVWW-130 SOUND LEVEL

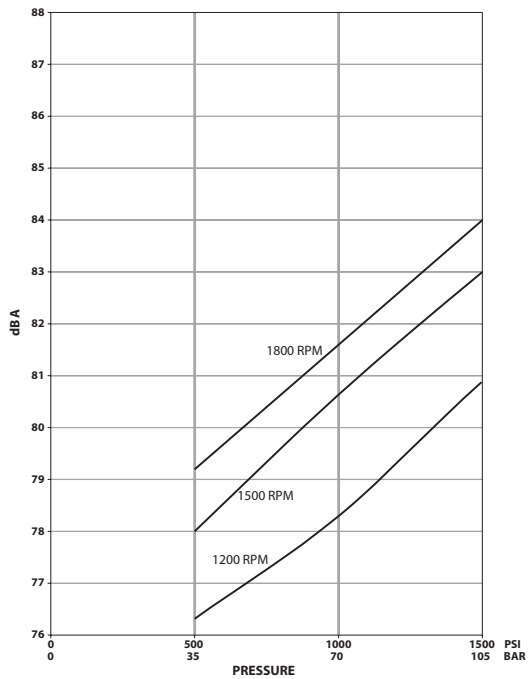

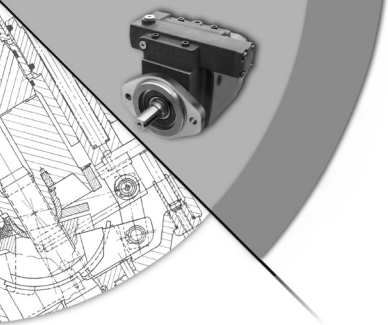

Frame Size A

PVWW-014

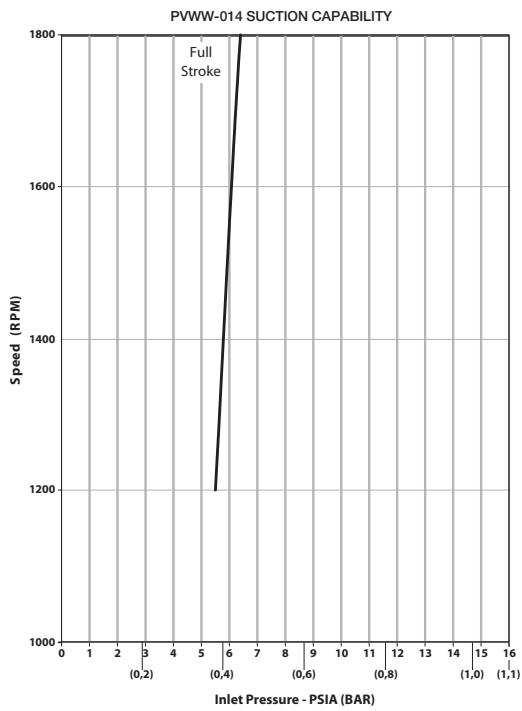

PVWW-022

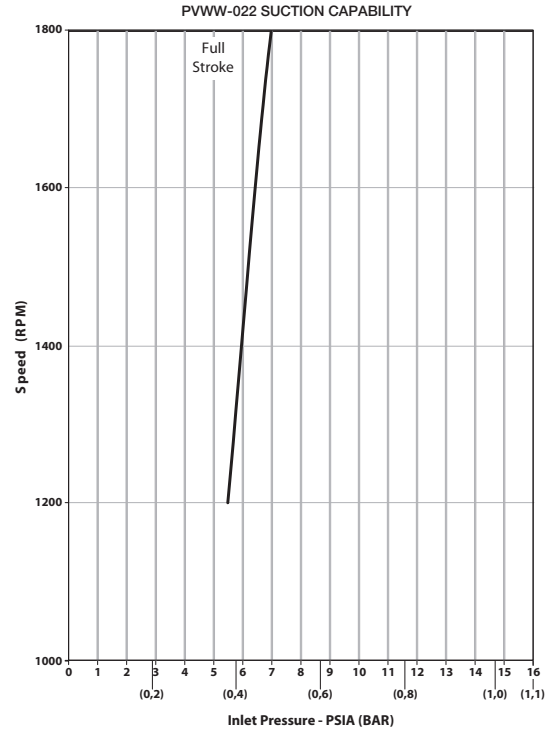

Frame Size B

PVWW-034

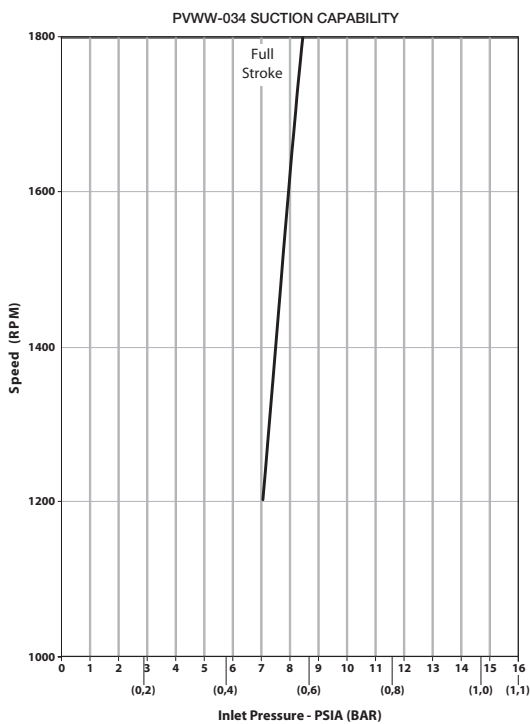

PVWW-046

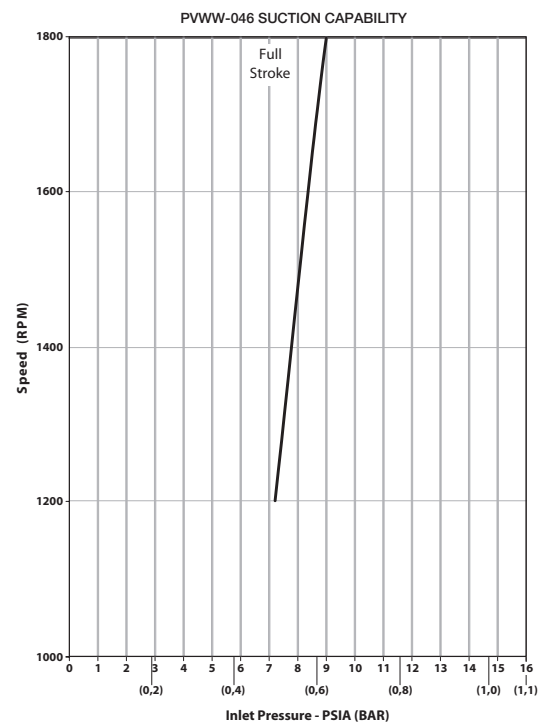

Frame Size C

PVWW-076

PVWW-076 SUCTION CAPABILITY

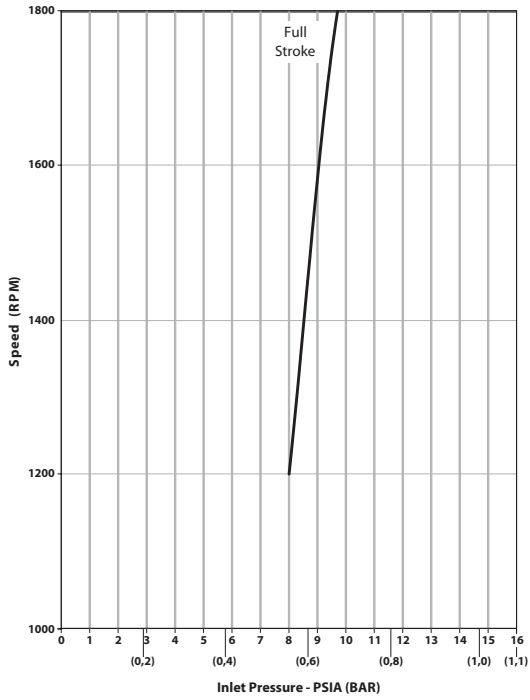

PVWW-098

PVWW-098 SUCTION CAPABILITY

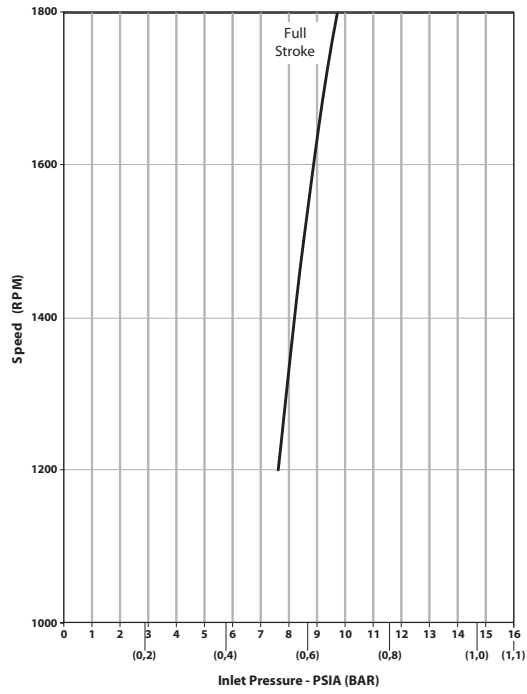

PVWW-130

PVWW-130 SUCTION CAPABILITY

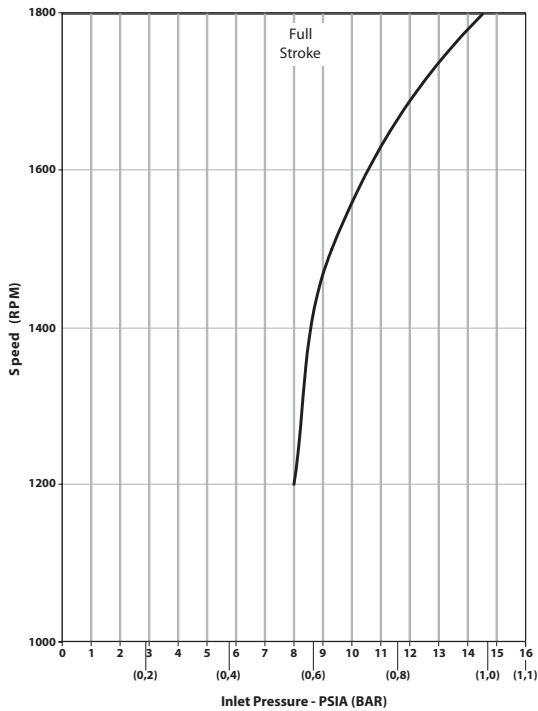

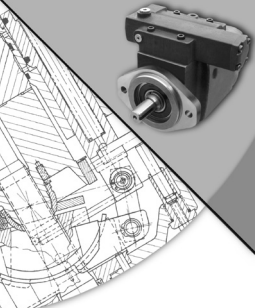

HOW TO ORDER

BLOCK NUMBER EXPLANATION	1	2	3	-	4	-	5	6	7	-	8	9	10	11	-	12	-	13a	13b	13c	13d	14	-	15	-	16
PVWW Model Code EXAMPLE	P	V	WW	-	098	-	A1	U	V	-	L	D	F	Y	-	P	-	1	N	N	/F	SN	-	AN	-	XXX

1 = UNIT
P = Pump

2 = TYPE
V = Variable

3 = DESIGN TYPE
WW= Pump Series

4 = UNIT SIZE

014 = 14.1 cc/rev (0.86 cipr) 022 = 22.1 cc/rev (1.35 cipr)	A Frame
034 = 33.8 cc/rev (2.06 cipr) 046 = 46.4 cc/rev (2.83 cipr)	B Frame
076 = 76.5 cc/rev (4.67 cipr) 098 = 98.3 cc/rev (6.00 cipr) 130 = 130.2 cc/rev (7.94 cipr)	C Frame

5 = DESIGN SERIES
A1= Current for all displacements

6 = DESIGN SERIES MODIFIER
U = SAE Connections & Mounting

7 = SHAFT & O-RING SEALS
V = Viton

8 = ROTATION
L = Left Hand (CCW)
R = Right Hand (CW)

9 = VALVE PLATE TYPE*
S = Rear Ported
G = Side Ported
D = Thru-Shaft w/Side-Ports
T = Top/Bottom Ported

10 = CONNECTION TYPE
A = SAE Straight Port*
F = SAE Flange
R = SAE Flange w/ Relief Valve

* All combinations of Valve Plate and
Connection types not available.
See Valve Plate Table below

Valve Plate Table (X = Available)

	SA	GA	DA	GF	DF	DR	TA
-014	X	X	X				X
-022	X	X	X				X
-034	X				X	X	
-046	X				X	X	
-076	X			X	X	X	
-098	X			X	X	X	
-130	X			X	X	X	

11 = SHAFT TYPE
See Shaft Table below.

12 = CONTROL TYPE
P = Pressure Compensating
M = Manual Stroking

13a = CONTROL OPTIONS
Pressure Controls
1 = Single PC Setting (standard)
2 = Dual PC Setting
L = Low PC Setting
C = Single PC w/Soft Start, NO
K = Single PC w/Soft Start, NC
H = High - Low PC

Manual Controls
N* = Pintle w/o Neutral Bypass
S* = Pintle w/ Neutral Bypass
H = Handwheel w/ Neutral Bypass
* for A and B frame only

13b = SOLENOID VOLTAGE
N for non-electrical control options
0 = 115/60 - 110/50 VAC
1 = 230/60 - 220/50 VAC
2 = 12 VDC
3 = 24 VDC

13c = CONNECTOR
N = No Connector for non-electrical
control options
R = .500 NPT w/o Lite
W = .500 NPT w/Lite
S = PG-11 w/o Lite
L = PG-11 w/Lite
E = Integral Deutsch DT04-2P

13d = CONTROL MODIFIER
Blank unless required option

/F = Fixed Load Sense 170 psi (11,7 bar)
/J = Adjustable Load Sense 100 - 220 psi
(7 - 15 bar)

/K = Adjustable Load Sense 225 - 350 psi
(15,5 - 24 bar)

/H = Horsepower Limiter
/G = Horsepower Limiter w/ Fixed Load Sense

/C = Horsepower Limiter with
Adjustable Load Sense 100 - 220 psi
(7 - 15 bar)

/D = Horsepower Limiter with
Adjustable Load Sense 225 - 350 psi
(15,5 - 24 bar)

13e = Horsepower Setting

Blank unless required option
Input Horsepower at 1800 rpm
(i.e. 045 = 45 horsepower)

To Calculate:

(1800 rpm / Actual rpm) X Required Horsepower
OR
(1800 rpm / Actual rpm X (Required kW X 1.34)

14 = STROKE LIMITER OPTION

NN = None
SN = Adjustable Max. Volume Stop
SA = Adjustable Min. Volume Stop
SB = Adjustable Min. & Max.
Volume Stops

15 = AUXILIARY ADAPTORS

(required for all thru-shaft units,
leave blank for all rear & side
ported units)

CP = Cover Plate
AN = SAE A Adaptor & Coupling
BN = SAE B Adaptor & Coupling
CN = SAE C Adaptor & Coupling
NN = No Adaptor or Coupling

16 = SPECIAL PUMP MODIFIER

XXX = Special Pump Modifier
(Factory Assigned)

Blank = Standard Unit

Shaft Table

Shaft Code	PVWW-014/022	PVWW-034/-046	PVWW-076/-098/-130
Y	.75" Keyed	.875" Keyed	1.25" Keyed
B	.875" Keyed	1.00" Keyed	—
S	SAE A Spline	SAE B Spline	SAE C Spline
C	SAE B Spline	SAE B-B Spline	—
D**	SAE A Spline	SAE B Spline	SAE C Spline

**D shafts are "industrial" versions of S shafts

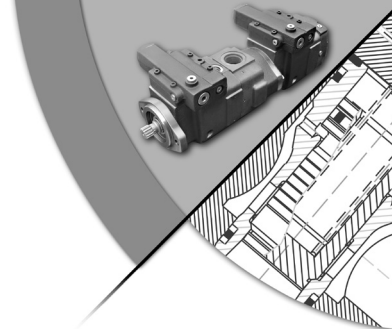

Installation Drawings	014, 022	034, 046	076,098,130
Pumps			
Basic Pump Rear Ported	DS-47480	DS-47483	DS-47487
Basic Pump Side Ported (Top and Bottom)	DS-47481	DS-47484	DS-47489
Basic Pump Thru Shaft	DS-47482	DS-47485	DS-47489
Dual Pump Adapter		DS-47490	
Controls			
P-1NN,P-LNN Single Pressure Compensator	DS-47984	DS-47985	DS-47986
P-1NN,P-LNN /F, /J, /K Single Pressure Compensator w/Load Sense	DS-47987	DS-47988	DS-47989
P-1NN/H Single Pressure Compensator w/Horsepower Limiter		DS-48112	DS-48113
P-1NN/G,/C,/D Single Pressure Comp w/Horsepower Limiter w/Load Sense		DS-48115	DS-48116
P-C, P-K Single Pressure Soft Start	DS-47990	DS-47991	DS-47992
P-2 Dual Pressure Compensator	DS-48105	DS-48106	DS-48107
M-N, M-S Lever Operated	DS-47993		
M-H Handwheel	DS-47996	DS-47997	DS-47998

For additional technical information refer to the Application Guidelines bulletin 847013.

Information in this bulletin subject to change without notice. Current versions of the documents referenced in this bulletin may have a letter at the end to denote the revision level. The latest release of any of any document, including this one, can be found on the Oilgear website or by contacting your Oilgear representative.

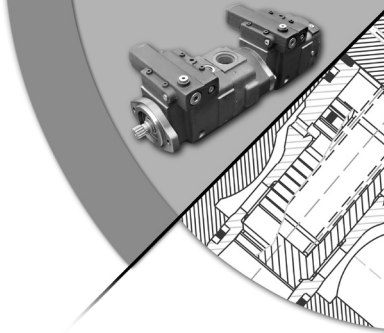

Oilgear Notes

Oilgear

World Headquarters

The Oilgear Company

2300 South 51st Street Milwaukee, WI USA 53219
phone: 414/327-1700 fax: 414/327-0532

www.oilgear.com

For more information about your application or the products in this brochure, please contact your nearest Oilgear facility. A complete listing of our global locations can be found on the Oilgear web site.