

Oilgear

PVWC TWO-WAY
VARIABLE DELIVERY
HYDROSTATIC (CLOSED LOOP) PUMPS





Table of Contents

Performance Assurance	page 3
Features and Benefits	4-5
Specifications	6-7
Dimensions and Weights	
Single Pump	8
Dual Pump	9-10
Controls	
Lever Operated	11
Lever Operated with Neutral Bypass	11
Center Assist	11
Electrohydraulic Servo Valve	11
Circuits	12
Performance Curves	13-14
How To Order	15

PERFORMANCE ASSURANCE – STANDARD WITH EVERY OILGEAR PUMP



Oilgear
PERFORMANCE
ASSURANCE

Every Oilgear product is shipped to you with our Performance Assurance — a corporate commitment to stay with your installation until our equipment performs as specified.

Hydraulic equipment and systems have been Oilgear's primary business since 1921. For decades, we have developed hydraulic techniques to meet the unique needs and unusual fluid power problems of machinery builders and users worldwide, matching fluid power systems to a tremendous range of applications and industries. Our exclusive Performance Assurance program is built upon that strong foundation.

As a customer, you also benefit from access to Oilgear's impressive technical support network. You'll find factory trained and field-experienced application engineers on staff at every Oilgear facility. They are backed by headquarters staff who can access the records and knowledge learned from decades of solving the most difficult hydraulic challenges.

When your design or purchase is complete, our service is just beginning. If you ever need us, our Oilgear engineers will be there, ready to help you with the education, field service, parts and repairs to assure that your installation runs smoothly — and keeps right on running.

Oilgear Performance Assurance

PVWC Closed Loop Pumps

Cylinder carried in polymerous journal bearing.

- Provides longer bearing life.
- Permits compact design.
- Allows operation with low viscosity or other special fluids.

Hardened cylinder surface running on hardened valve plate.

- Greater resistance to contamination.
- Provides longer life.
- Allows operation with low viscosity or other special fluids.

Built-in supercharge and/or implement pump available.

- Circuited to replenish piston pump in (closed loop) hydrostatic circuits.
- Provides for operation of implement or system accessories.

Thru-shaft and "plug-in" rear coupling availability (after removal of rear cover).

- Allows multiple pump installation from a single driveshaft.
- Can be used to drive auxiliary devices.

Three capacities per single frame size.

- Allows selection of capacity (speed) and pressure (torque) to most closely match the need while providing maximum control range sensitivity (gain).

Large selection of controls.

- Several types of mechanical, hydraulic and electrohydraulic servo valve controls are available.
- Allow cushioned "across-center" delivery reversal.
- Field interchangeability without disconnecting pump from main drive or system piping.
- Neutral "by-pass" types available.

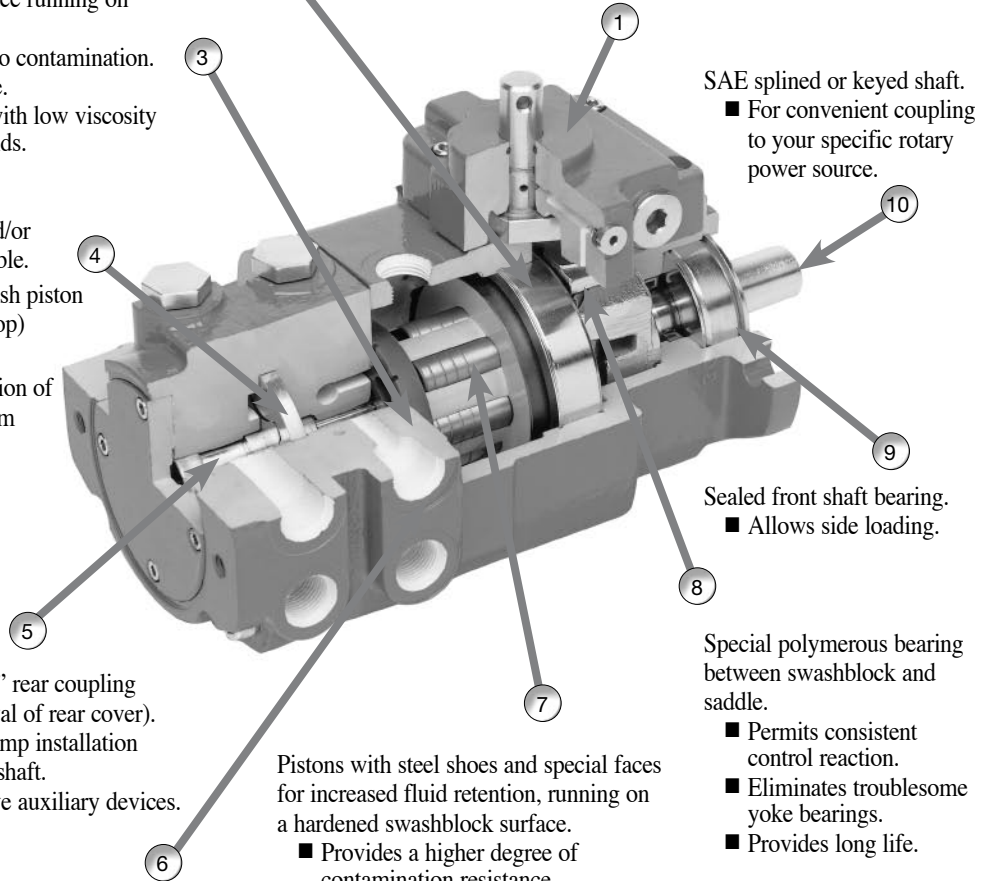

SAE splined or keyed shaft.
■ For convenient coupling to your specific rotary power source.

Sealed front shaft bearing.
■ Allows side loading.

Special polymerous bearing between swashblock and saddle.
■ Permits consistent control reaction.
■ Eliminates troublesome yoke bearings.
■ Provides long life.

Pistons with steel shoes and special faces for increased fluid retention, running on a hardened swashblock surface.

- Provides a higher degree of contamination resistance.
- Allows higher pressure operation.
- Provides longer life.
- Allows operation with low viscosity or other special fluids.

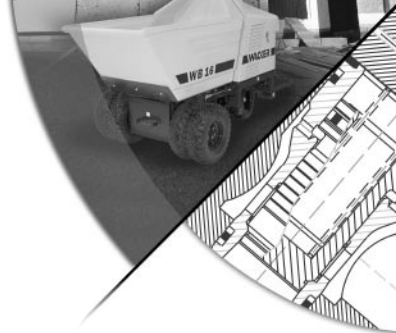

Oilgear Features and Benefits

Two cross-line check valves with (optional) high pressure relief valves.

- Automatically provide replenishing volume to low pressure side of circuit.
- Protect high pressure pump drive and machine from overload damage if system pressure is exceeded.
- Provide cushioned hydrodynamic or regenerative braking of driven hydraulic motor.

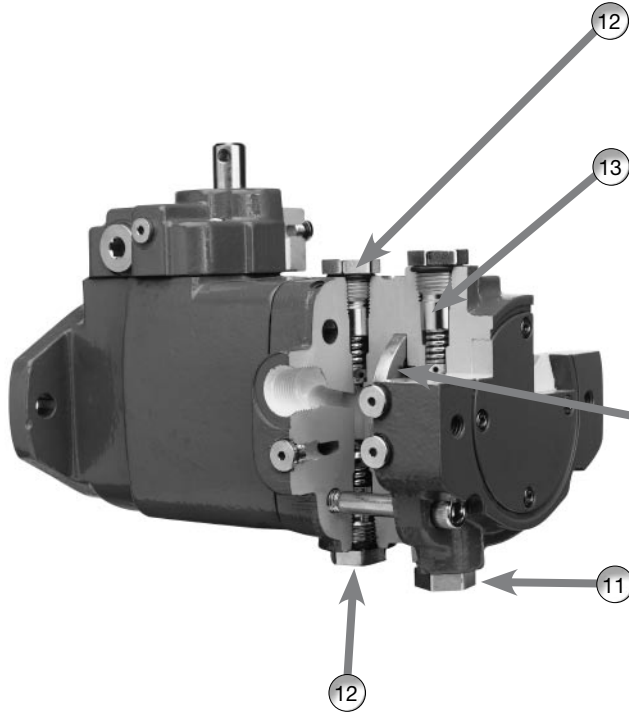

Built-in implement pressure relief valve available.

- Protects implement (or accessory) circuit and supercharge pump from overload pressure and damage.

See previous page

Built-in supercharge pressure relief valve.

- Maintains back pressure in the supercharge circuit to replenish piston pump.
- Allows surplus return and/or supercharge volume to escape system.

See above

PLUS Not Shown in cross section photos

- (14) Totally enclosed.
 - Impervious to high pressure wash down.
 - Can be operated in hazardous locations, with totally enclosed drive motors.
- (15) Can be easily mounted in any position.
 - Easy to install.
- (16) "Tow" valve option.
 - Allows "free-wheeling" of hydraulic motor when being transported (towed).

SPECIFICATIONS

	PUMP MODEL		
	PVWC-011	PVWC-014	PVWC-022
Maximum Piston Pump Displacement	0.66 cipr 10.8 cc/rev	0.86 cipr 14.1 cc/rev	1.35 cipr 22.1 cc/rev
Operating Pressure (see Note 1)			
Rated Continuous	4000 psi (275 bar)	4000 psi (275 bar)	3000 psi (207 bar)
Maximum Intermittent (10% of duty)	4500 psi (310 bar)	4500 psi (310 bar)	3500 psi (240 bar)
Peak	5000 psi (350 bar)	5000 psi (350 bar)	5000 psi (350 bar)
Output Flow (see Note 2) (@ 1800 rpm & Rated Cont Pressure)	4.1 gpm (15.5 lpm)	5.4 gpm (20.4 lpm)	8.5 gpm (32.2 lpm)
Input Shaft Speed			
Minimum	600 rpm	600 rpm	600 rpm
Continuous	3600 rpm	3600 rpm	3600 rpm
Intermittent	4000 rpm	4000 rpm	4000 rpm
Charge Pressure (@ 1800 rpm)			
Nominal	75 psi (5 bar)	75 psi (5 bar)	75 psi (5 bar)
Minimum	30 psi (2 bar)	30 psi (2 bar)	30 psi (2 bar)
Case Pressure			
Maximum Continuous	15 psi (1 bar)	15 psi (1 bar)	15 psi (1 bar)
Maximum Intermittent	100 psi (7 bar)	100 psi (7 bar)	100 psi (7 bar)
Hydraulic Fluid Temp (@ pump inlet)			
Minimum	-40° F (-40° C)	-40° F (-40° C)	-40° F (-40° C)
Maximum	200° F (95° C)	200° F (95° C)	200° F (95° C)
Charge Pump Displacement (Optional)	.425 cipr (7 cc/rev) or .64 cipr (10.5 cc/rev)		
Operating Pressure			
Rated Continuous	1000 psi (69 bar)		
Maximum Intermittent (10% of duty)	1450 psi (100 bar)		

Note 1: Running Piston Pumps above pressures indicated will shorten the pump's life.
To avoid damage, supercharge flow must be continuously supplied to the piston pump.

Note 2: Output flow based on ISO 46 hydraulic fluid at 125° F.

Pump Mount (all displacements)	SAE "A" 2-bolt or SAE "B" 2-bolt
Input Shaft Options (all displacements)	7/8" Keyed SAE A Spline (9 tooth, 16/32) SAE B Spline (13 tooth, 16/32) 11 tooth, 16/32 Spline
Port Type (all displacements)	#8 SAE Straight Thread (all connections except inlet port of .64 cipr Charge Pump are #10 SAE Straight Thread)
Direction of Rotation (all displacements)	Clockwise or Counterclockwise
Installation Position (all displacements)	Horizontal or Vertical at any clocking
Tandem Mount (all displacements)	SAE "A" 2-bolt with SAE "A" Spline drive

PVWC High Pressure & Implement Relief Valve Specs

High Pressure Relief Valve (Block number 16 of model code)

MODEL CODE DESIGNATION	NOMINAL SETTING	CRACKING PRESSURE	
		Minimum	Maximum
10	1450 psi (100 bar)	1378 psi (95 bar)	1523 psi (105 bar)
14	2030 psi (140 bar)	1929 psi (133 bar)	2132 psi (147 bar)
17	2500 psi (175 bar)	2410 psi (166 bar)	2664 psi (184 bar)
19	2730 psi (188 bar)	2610 psi (180 bar)	2842 psi (196 bar)
21	3045 psi (210 bar)	2893 psi (200 bar)	3197 psi (220 bar)
25	3625 psi (250 bar)	3444 psi (238 bar)	3806 psi (262 bar)
28	4060 psi (280 bar)	3857 psi (266 bar)	4263 psi (294 bar)
35	5075 psi (350 bar)	4821 psi (332 bar)	5329 psi (368 bar)

Implement Pressure Relief Valve (Block number 17 of model code)

MODEL CODE DESIGNATION	NOMINAL SETTING	CRACKING PRESSURE	
		Minimum	Maximum
J	725 psi (50 bar)	689 psi (48 bar)	761 psi (52 bar)
E or F	913 psi (63 bar)	867 psi (60 bar)	959 psi (66 bar)
K	1160 psi (80 bar)	1102 psi (76 bar)	1218 psi (84 bar)
L	1450 psi (100 bar)	1378 psi (95 bar)	1523 psi (105 bar)

Recommended Circuit for Dual Outputs and Hydraulic Stroke Control

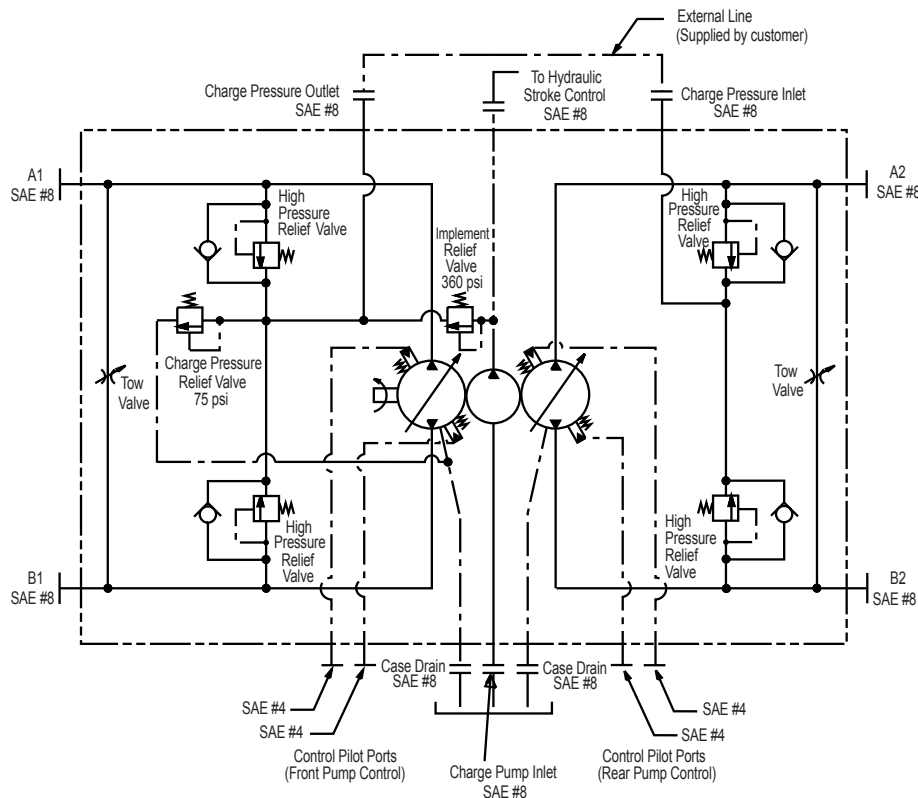

SINGLE PUMP

SINGLE UNIT WITH INTEGRAL CHARGE PUMP

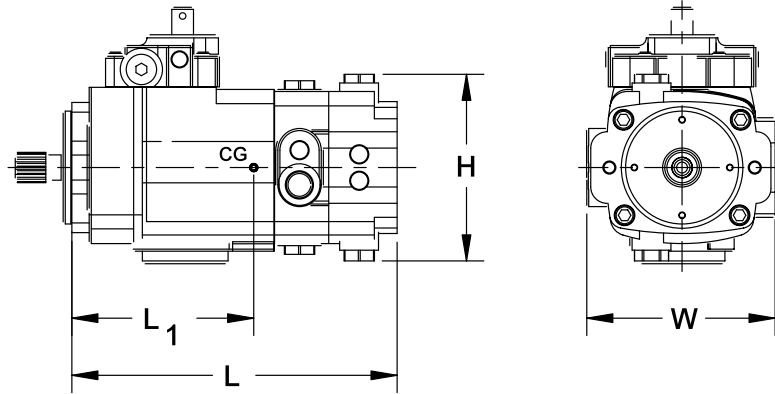

PUMP MOUNT	CHARGE PUMP	L IN. (MM)	H IN. (MM)	W IN. (MM)	WEIGHT * LB. (KG)	L ₁ IN. (MM)
A	.425 CIPR	9.4 (238,8)	5.4 (137,2)	5.2 (132,1)	38.0 (17,3)	4.7 (119)
A	.64 CIPR	9.6 (243,8)	5.4 (137,2)	5.2 (132,1)	38.7 (17,6)	4.8 (122)
B	.425 CIPR	9.4 (238,8)	5.4 (137,2)	5.2 (132,1)	41.2 (18,7)	4.5 (114)
B	.64 CIPR	9.6 (243,8)	5.4 (137,2)	5.2 (132,1)	41.9 (19,0)	4.6 (117)

* WEIGHTS ARE FOR MN/MS CONTROLS. ADD 2.4 LBS (1,1 KG) FOR CA CONTROL OR 11.0 LBS (5 KG) FOR VS AND VM CONTROLS.

SINGLE UNIT WITHOUT CHARGE PUMP

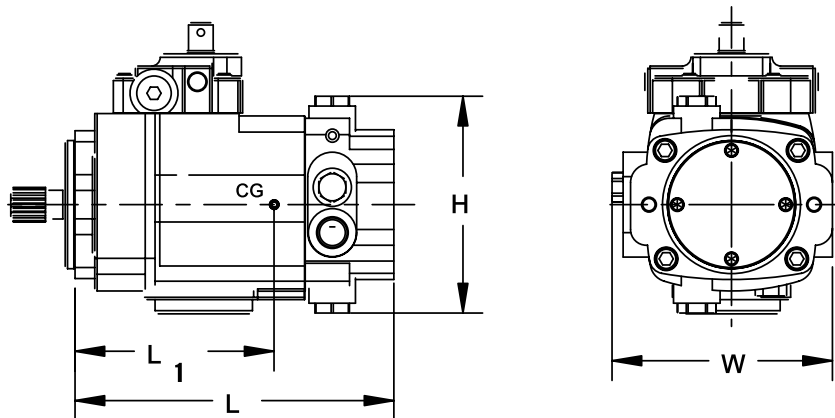

PUMP MOUNT	L IN. (MM)	H IN. (MM)	W IN. (MM)	WEIGHT * LB. (KG)	L ₁ IN. (MM)
SAE "A"	7.1 (108,3)	5.4 (137,2)	5.2 (132,1)	33.4 (15,2)	3.9 (99,1)
SAE "B"	7.1 (108,3)	5.4 (137,2)	5.2 (132,1)	36.6 (16,6)	3.7 (94,0)

* WEIGHTS ARE FOR MN/MS CONTROLS. ADD 2.4 LBS (1,1 KG) FOR CA CONTROL OR 11.0 LBS (5 KG) FOR VS AND VM CONTROLS.

All dimensions are approximate. For detailed information, contact your Oilgear representative.

DUAL PUMP

PUMP COMBINATIONS

Two or more PVWC variable delivery pumps can be integrally coupled together, without the use of an adapter, and driven from a single shaft. NOTE: the total torque of the combination may not exceed that shown in the table below. The torque may be divided between multiple units in any fashion as long as the total does not exceed this value.

Unit Size	011, 014 & 022
Torque - inch lbs.	1290
N.m.	145,8

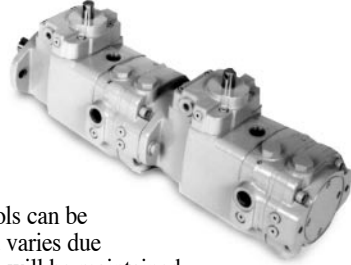

When used individually to operate individual hydraulic motors, the individual pump controls can be used to synchronize speeds or to establish differential speeds. If the main driveshaft speed varies due to load etc., the individual motors will stay in synchronization or the set differential speeds will be maintained.

Or, pump deliveries can be combined for larger volume circuits.

FRONT WITH INTEGRAL CHARGE PUMP, REAR UNIT WITHOUT CHARGE PUMP.

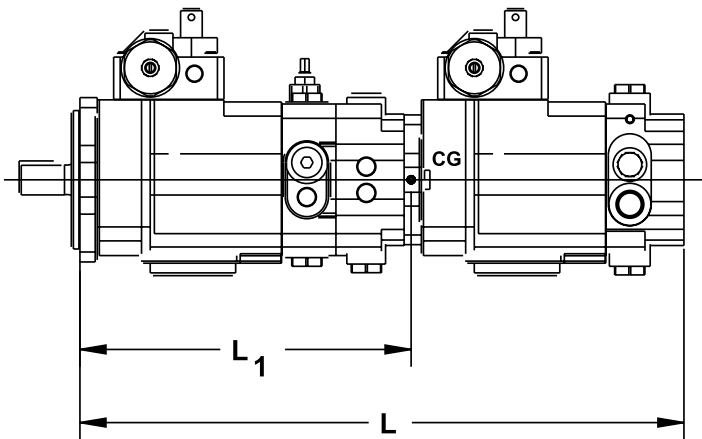

FRONT PUMP MOUNT	L* IN. (MM)	WEIGHT* LB. (KG)	L1 IN. (MM)
SAE "A"	16.5 (419,1)	71.4 (32,5)	8.7 (221,6)
SAE "B"	16.5 (419,1)	74.6 (33,9)	8.4 (213,4)

* "L" AND WEIGHTS ARE FOR THE .425 CIPR CHARGE PUMP. ADD 0.2 IN. (5 MM) TO "L" AND 0.7 LBS (0,3 KG) TO WEIGHT FOR .64 CIPR CHARGE PUMP.

All dimensions are approximate. For detailed information, contact your Oilgear representative.



PUMP COMBINATIONS

MULTIPLE UNITS BOTH WITH INTEGRAL CHARGE PUMPS.

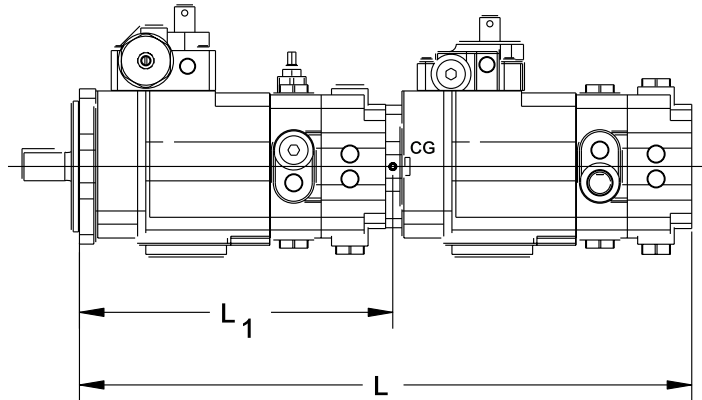

CHARGE PUMP	L* IN. (MM)	WEIGHT* LB. (KG)	L ₁ IN. (MM)
.425 CIPR	18.8 (477,6)	76.0 (34,5)	9.4 (238,8)
.64 CIPR	19.2 (487,6)	77.4 (35,2)	9.6 (243,8)

* "L" AND WEIGHTS ARE FOR THE .425 CIPR CHARGE PUMP. ADD 0.4 IN. (10 MM) TO "L" AND 1.4 LBS (0,6 KG) TO WEIGHT FOR .64 CIPR CHARGE PUMP.

PUMP CONTROLS

■ Lever Operated

“MN”

Varies displacement and direction of flow proportional to the rotation of a pintle.

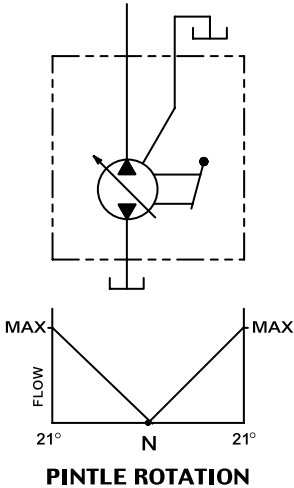

■ Lever Operated with Neutral Bypass

“MS”

Varies displacement and direction of flow proportional to the rotation of a pintle which is equipped with “neutral” bypass to prevent “creep” when centered.

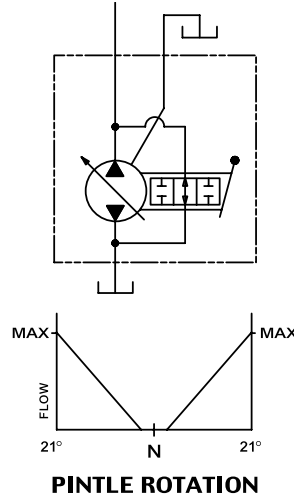

■ Center Assist

“CA”

Single-spring centering mechanism with external neutral adjustment. Varies displacement and direction of flow proportional to rotation of a pintle or hydraulic pilot pressure. Equipped with “Neutral” bypass feature.

MECHANICAL

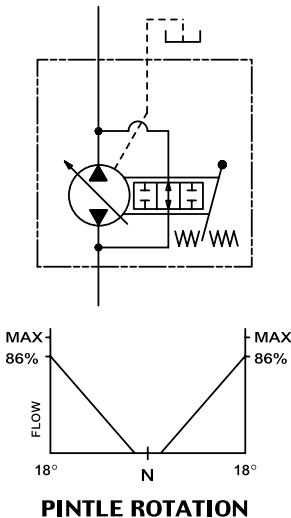

HYDRAULIC

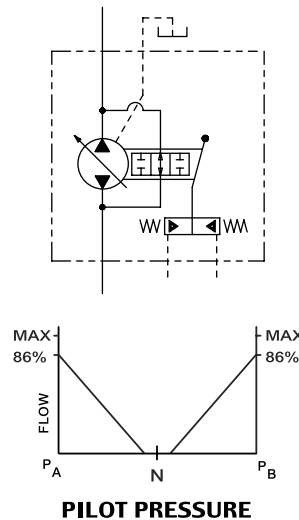

■ Electrohydraulic Servo Valve

“VS” or “VM”

VS: an electrohydraulic servo valve positions the swashblock mechanism with a closed loop position control (with LVDT feedback) providing high accuracy remote variable delivery control.

VM: similar to “VS” except uses a direct operated servo valve for faster response.

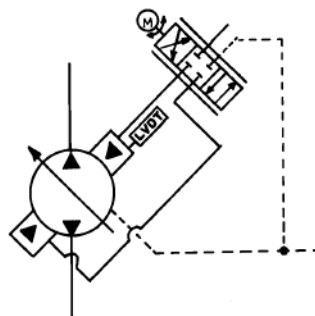

FIGURE 1

Standard PVWC
With Gerotor Charge Pump & Implement Relief Valve

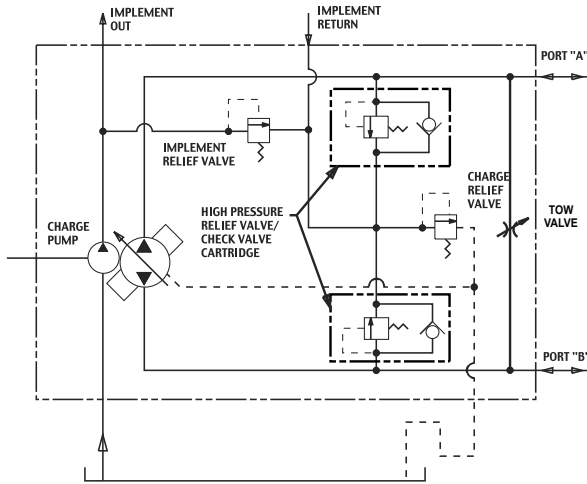

FIGURE 2

Standard PVWC
With Gerotor Charge Pump, No Implement Relief Valve
(Externally Ported)

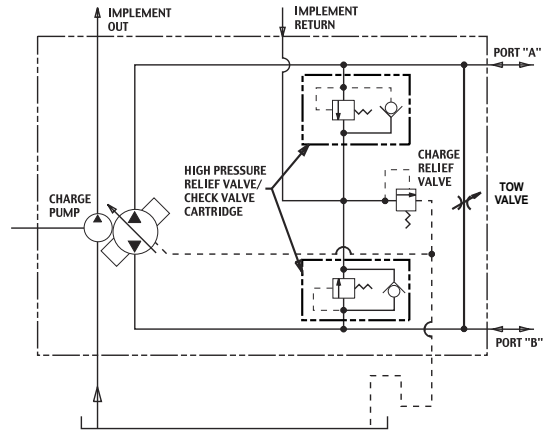

FIGURE 3

Standard PVWC
With Gerotor Charge Pump, No Implement Relief Valve
(Internally Ported)

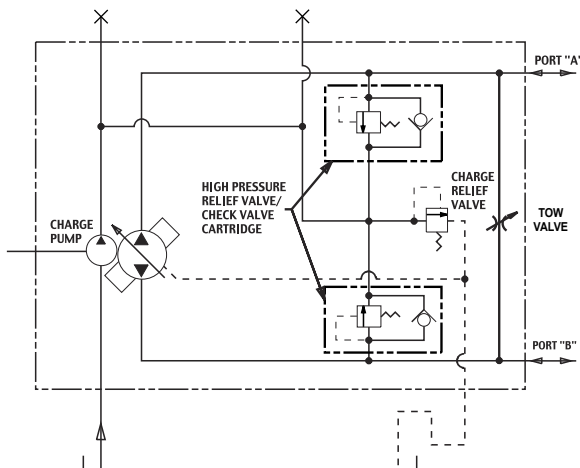
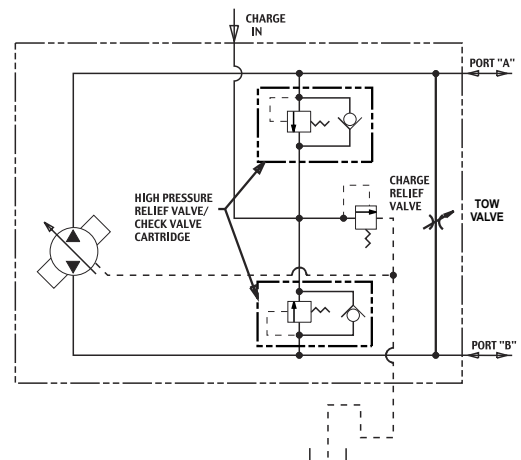

FIGURE 4

Gerotorless PVWC



PERFORMANCE

The following single pump curves are based on ISO 46 hydraulic fluid at 125° F.

PVWC-011

PVWC-011 Performance

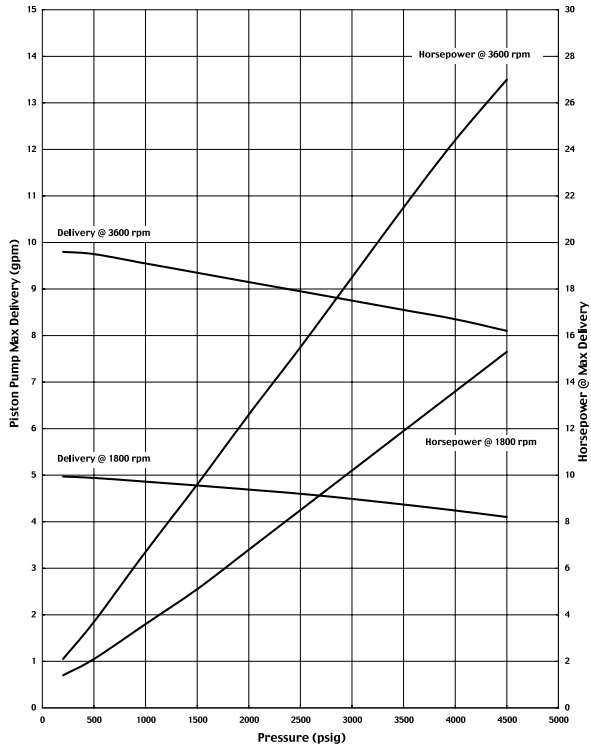

PVWC-014

PVWC-014 Performance

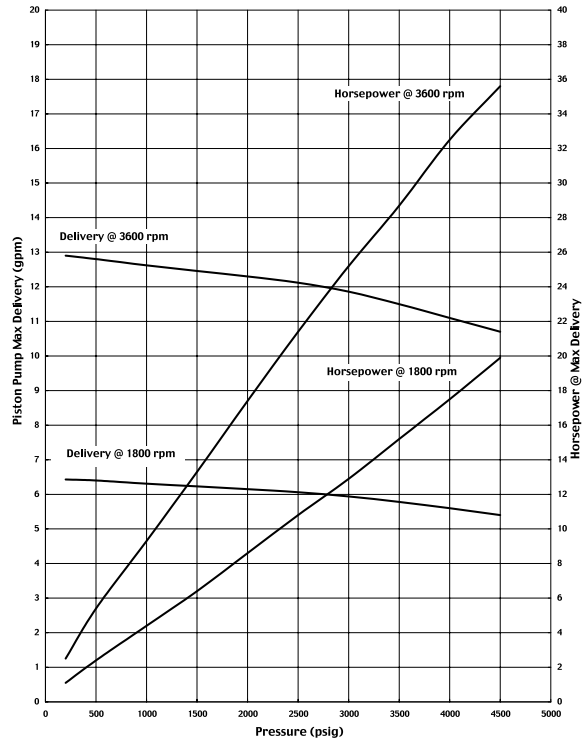

PVWC-022

PVWC-022 Performance

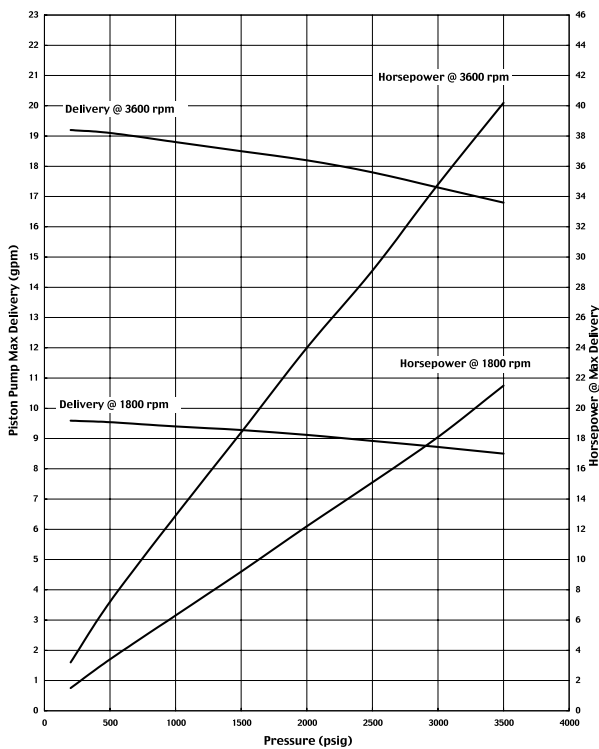

.425 cibr Charge Pump Performance

.425 cibr Charge Pump Performance

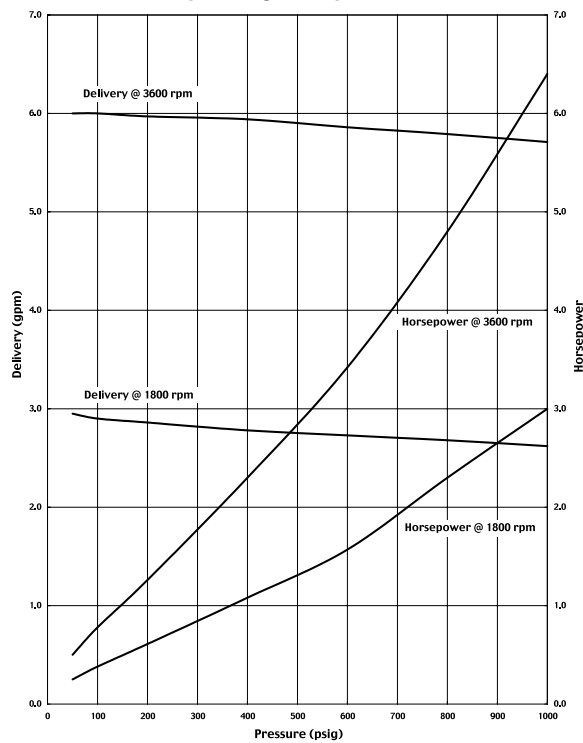

Oilgear Performance Curves



The following single pump curves are based on ISO 46 hydraulic fluid at 125° F.

■ .64 CIPR Charge Pump

.64 cipr Charge Pump Performance

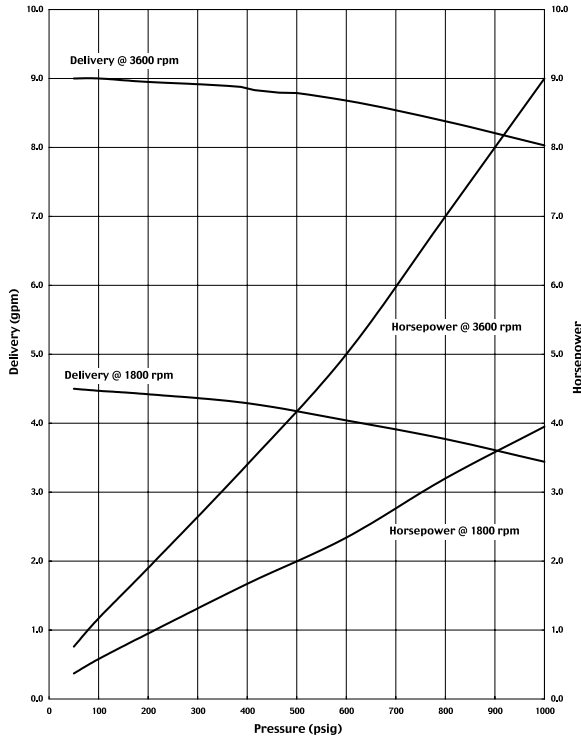

■ Charge Pump Delivery

Charge Pump Delivery

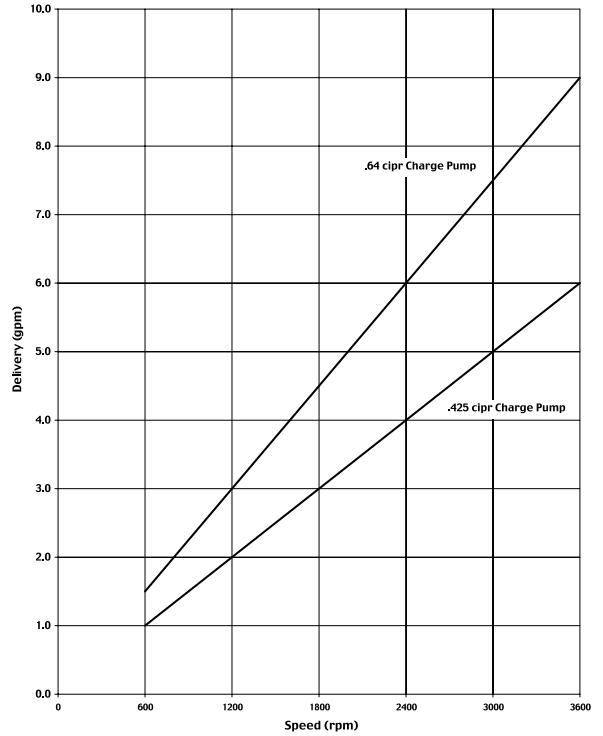

■ Charge Pressure Curve and Implement RV Data

Charge Pressure Relief Valve

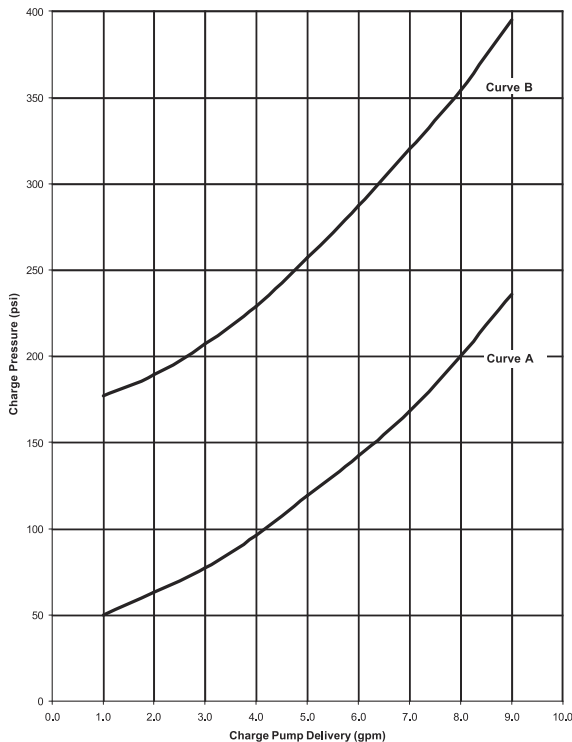

IMPLEMENT & CHARGE RV CIRCUITRY DATA

Code	Implement RV	Charge RV
J	725 psi (50 bar)	Curve A
F	913 psi (63 bar)	Curve A
E	913 psi (63 bar)	Curve B
K	1160 psi (80 bar)	Curve A
L	1450 psi (100 bar)	Curve A
N	None	None
G	None	Curve A
B	None	Curve B
H	None	Curve A
A	None	Curve B

See complete model code, page 15.

See Circuits, page 12.

HOW TO ORDER

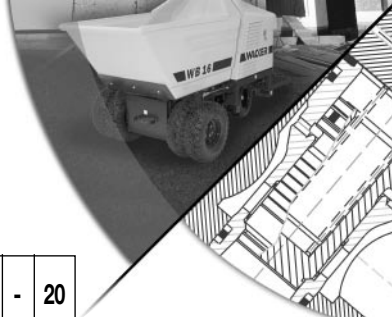

Dual Pump Example

BLOCK NUMBER EXPLANATION	1	2	3	-	4	-	5	6	7	8	-	9	10	11	12	-	13	14	15	-	16	17	-	18	-	19	-	20
FRONT PUMP	P	V	WC	-	014	-	B	5	U	V	-	L	H	A	L	-	MN	NN	NN	-	21	F	-	42	-	NN	/	
REAR PUMP	P	V	WC	-	011	-	A	5	U	V	-	L	H	A	S	-	MN	NN	NN	-	21	F	-	42	-	NN	-	04

Single Pump Example

BLOCK NUMBER EXPLANATION	1	2	3	-	4	-	5	6	7	8	-	9	10	11	12	-	13	14	15	-	16	17	-	18	-	19	-	20
	P	V	WC	-	014	-	A	5	U	V	-	L	H	A	C	-	MN	NN	NN	-	21	F	-	42	-	NT		

1 = UNIT
P = Pump

2 = TYPE
V = Variable

3 = DESIGN TYPE
WC = Closed Loop

4 = UNIT SIZE
011 = 0.66 cipr (11 cc/rev)
014 = 0.86 cipr (14 cc/rev)
022 = 1.35 cipr (22 cc/rev)

5 = HOUSING MOUNT
A = SAE "A" 2-Bolt
B = SAE "B" 2-Bolt

6 = DESIGN SERIES (subject to change)
5 = Current

7 = DESIGN SERIES MODIFIER
U = SAE Mounting & Ports

8 = SEALS
V = Viton (std.)

9 = ROTATION
L = Left-hand (CCW)
R = Right-hand (CW)

10 = VALVE PLATE TYPE
M = w/ Tow Valve
H = w/o Tow Valve

11 = PORTS
A = SAE (Std.)

12 = SHAFT TYPE
Y = .875 dia Keyed
S = 9T SAE A Spline, Loose Fit
L = 13T SAE B Spline x 1.62 lg, Class 5 Fit
R = 13T SAE B Spline x 1.62 lg, Loose Fit
K = 13T SAE B Spline x 1.25 lg, Loose Fit
C = 11T, 16/32 Spline x 1.40 lg, Class 7 Fit

13 = CONTROL TYPE
MN = Mechanical (Pintle input) w/o Neutral Bypass
MS = Mechanical (Pintle input) w/Neutral Bypass
VS = Servo Valve
VM = Direct Operated Servo Valve
CA = Center Assist Control

14 = CONTROL MODIFIER 1
NN for MN, MS & CA Controls
20 = for 20 lpm Servo Valve (VM Control)
25 = for 25 lpm Servo Valve (VS or VA control)
NN = No Servo Valve

15 = CONTROL MODIFIER 2
NN = No stops (for CA, VM, VS)
SA = Adjustable stop on A-side
SN = Adjustable stop on B-side
SB = Adjustable stops on both sides
01 = Manual CA Control w/o Neutral Switch
03 = Manual CA Control w/N.C. Neutral Switch
04 = Hydraulic CA Control w/o Neutral Switch
06 = Hydraulic CA Control w/N.C. Neutral Switch

16 = HP RV SETTING
00 = No Relief Valves
10 = 1450 psi (100 bar)
14 = 2030 psi (140 bar)
17 = 2500 psi (175 bar)
19 = 2730 psi (188 bar)
21 = 3045 psi (210 bar)
25 = 3625 psi (250 bar)
28 = 4060 psi (280 bar)
35 = 5075 psi (350 bar)

17 = IMPLEMENT & CHARGE RV CIRCUITRY DATA

Code	Implement RV	Charge RV*	Circuit**
J	725 psi (50 bar)	Curve A	Fig 1
F	913 psi (63 bar)	Curve A	Fig 1
E	913 psi (63 bar)	Curve B	Fig 1
K	1160 psi (80 bar)	Curve A	Fig 1
L	1450 psi (100 bar)	Curve A	Fig 1
N	None	None	Fig 2 or 4
G	None	Curve A	Fig 2 or 4
B	None	Curve B	Fig 2 or 4
H	None	Curve A	Fig 3
A	None	Curve B	Fig 3

* See Charge Pressure Relief Valve Curve, page 14
** See Circuits, page 12

18 = CHARGE PUMP
42 = 0.425 cipr (7 cc/rev)
64 = 0.64 cipr (10.5 cc/rev)
NN = None

19 = AUXILIARY ADAPTORS
NN = Standard Thru-Shaft
CP = Cover Plate
NT = Non-thru Shaft

20 = GEAR PUMPS
Blank = None
04 = 0.488 cipr
07 = 0.672 cipr
10 = 0.976 cipr
14 = 1.403 cipr
20 = 2.015 cipr

Note:
Please inform Oilgear Sales if the application will use a water-based fluid.

Shaft Note:
Spline Shafts S, R, K, and C should be used for rigid internal drives such as gear boxes and internally splined electric motors. Spline Shaft L should be used for clamped and slip fit flexible couplings.

Oilgear How to Order

Oilgear

World Headquarters
The Oilgear Company

2300 South 51st Street Milwaukee, WI USA 53219
phone: 414/327-1700 fax: 414/327-0532

www.oilgear.com

For more information about your application or the products
in this brochure, please contact your nearest Oilgear facility.



AUSTRALIA

Oilgear Towler Australia Pty. Ltd.

BRAZIL

Oilgeardo Brazil Hydraulica Ltd.

CANADA

The Oilgear Company

FRANCE

Oilgear Towler S.A.

GERMANY

Oilgear Towler GmbH

INDIA

Oilgear Towler Polyhydron Pvt. Ltd.
Towler Automation Pvt. Ltd.

ITALY

Oilgear Towler S.r.l.

JAPAN

The Oilgear Japan Company

KOREA

Oilgear Towler Korea Co. Ltd.

MEXICO

Oilgear Mexicana S.A. de C.V.

SPAIN

Oilgear Towler S.A.

TAIWAN

Oilgear Towler Taiwan Co. Ltd.

UNITED KINGDOM

Oilgear Towler Ltd.

UNITED STATES OF AMERICA

The Oilgear Company

