

Features & Advantages

3

- + The high flow design provides flow rates with minimal pressure drops.
- + 3 1/4" or 5" valve center options allow the manifold to be sized for specific D05 valve types.
- + Standard end mount and through holes make mounting easy and flexible. Also, (when requested) mounting bracket kit BK-A05 (no charge) is supplied as alternative end mounting style.
- + Available with SAE, NPT, BSPP, BSPT or Metric Threads to cover a wide range of applications.
- + Options include relief valve cavity, bottom PR & TK ports, and gauge port to fit specific circuit requirements.

Dimensions (3.25" Valve Spacing)

No. of Stations	C	L*	E	F
1	- -	3.75"	2.45"	-
2	3.25"	6.50"	5.70"	-
3	3.25"	9.75"	8.95"	-
4	3.25"	13.00"	12.20"	6.50"
5	3.25"	16.25"	15.45"	6.50"
6	3.25"	19.50"	18.70"	6.50" & 13.00"
7	3.25"	22.75"	21.95"	6.50" & 13.00"

* Note: For Single Station with C, S, G, G6 or B Option, "L" = 4.75"

Dimensions (5.00" Valve Spacing)

No. of Stations	C	L	E	F
2	5.00"	8.25"	7.45"	-
3	5.00"	13.25"	12.45"	-
4	5.00"	18.25"	17.45"	10.00"
5	5.00"	23.25"	22.45"	10.00"
6	5.00"	28.25"	27.45"	10.00" & 20.00"
7	5.00"	33.25"	32.45"	10.00" & 20.00"

MAGNALOY D05E ALT. A PARALLEL BAR MANIFOLD PART NUMBER BREAKDOWN

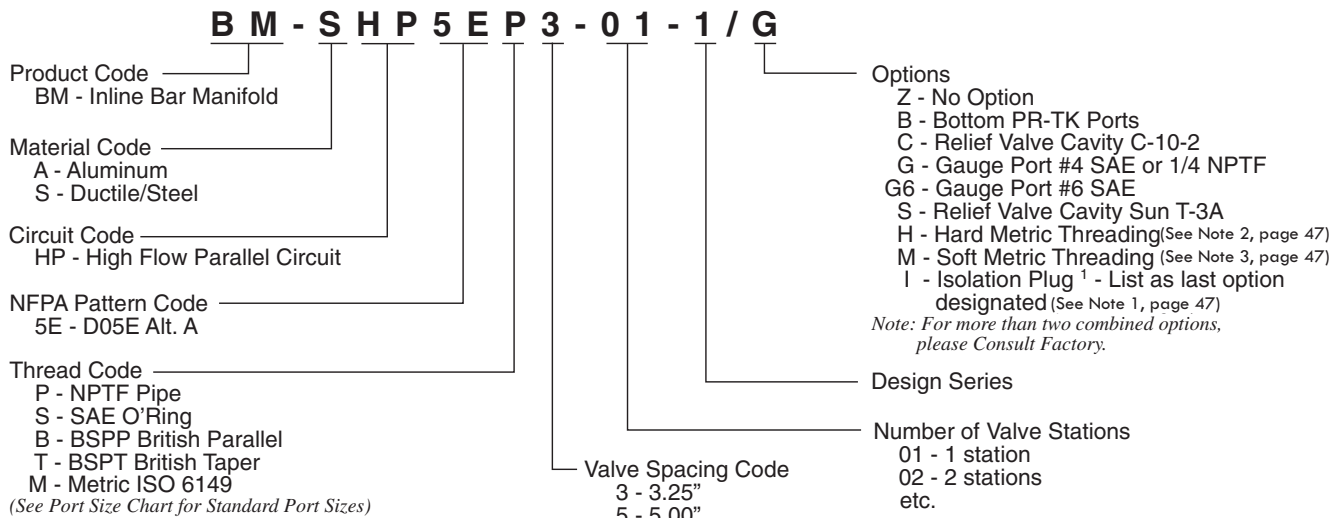

Inline Bar Manifold

D05 E Alt. A Bar Manifold - Parallel

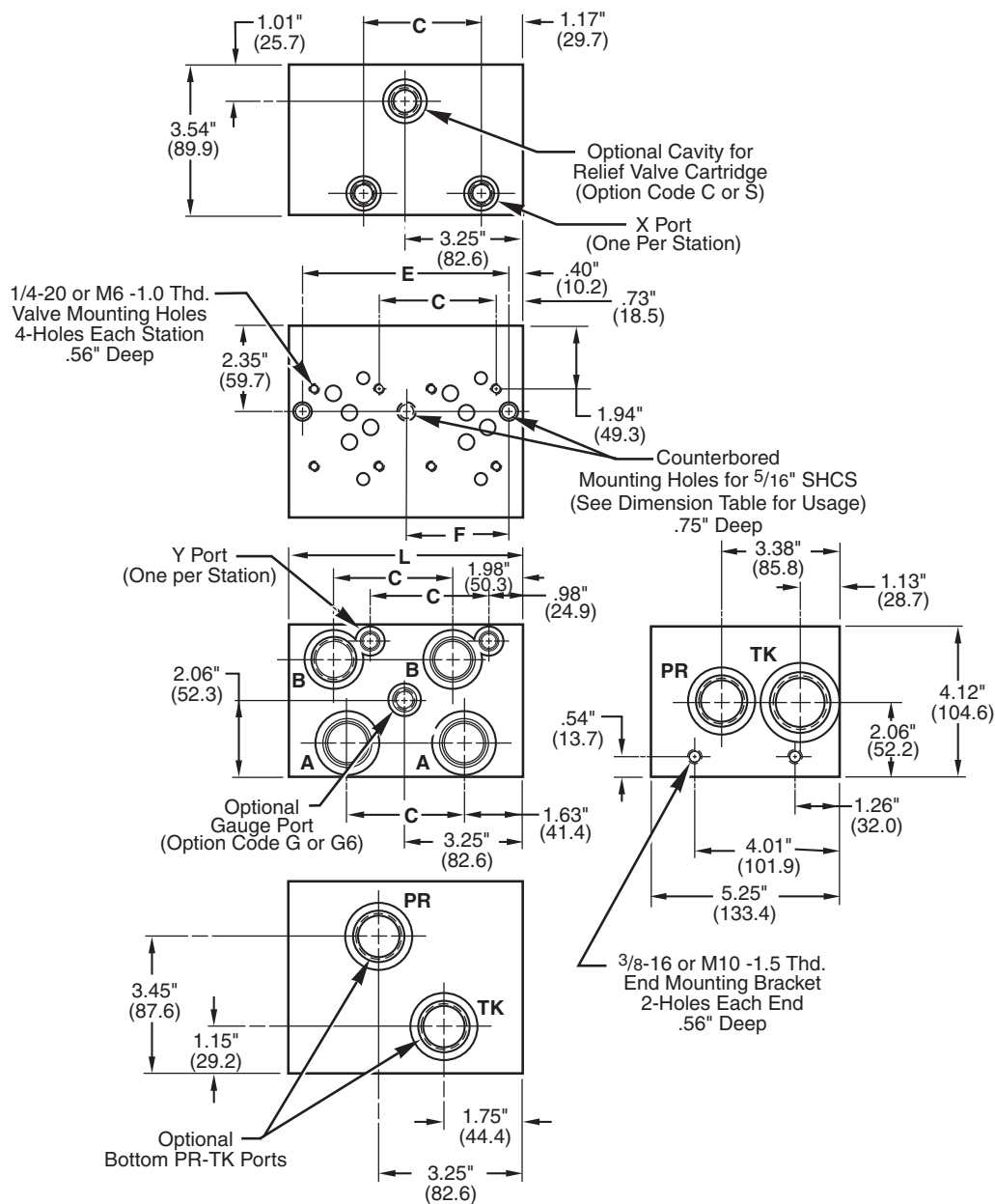

Note: For **Mounting Bracket Kit (BK-A05)** dimensions, see Reference Section, page 203.

Port Size Chart

Thread Code	PR	TK	A & B	Optional Gauge Ports	X & Y
P	1" NPT	1 1/4" NPT	3/4" NPT	1/4" NPT	1/4" NPT
S	#16 SAE	#20 SAE	#12 SAE	#4 SAE G6 - #6 SAE	#4 SAE
B	1" BSPP	1 1/4" BSPP	3/4" BSPP	-	1/4" BSPP
T	1" BSPT	1 1/4" BSPT	3/4" BSPT	-	1/4" BSPT
M	M33	M42	M27	-	M12