

D03 Tapping Plates

P and T Port Tapping Plate

Tapping Plate hardware / interface seal kit is supplied. See page 180 for itemized list.

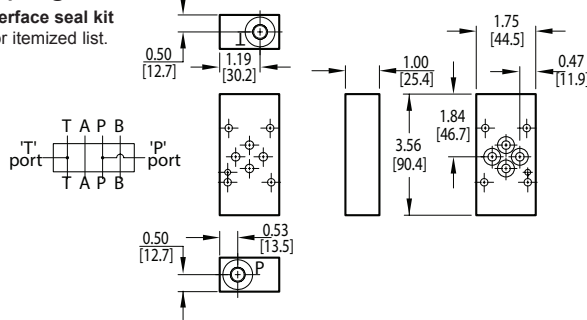

A and B Port Tapping Plate

Tapping Plate hardware / interface seal kit is supplied. See page 180 for itemized list.

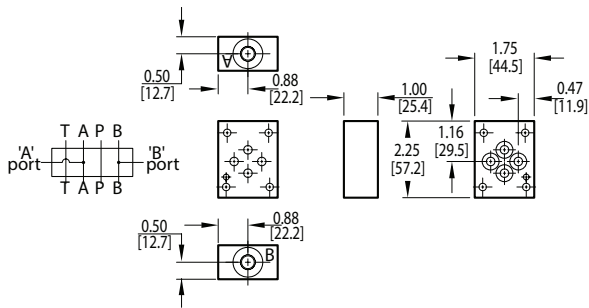

L Port Tapping Plate

Tapping Plate hardware / interface seal kit is supplied. See page 180 for itemized list.

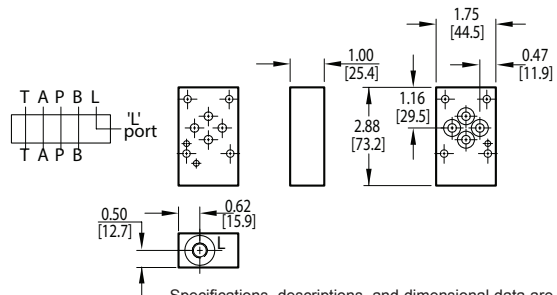

Specifications, descriptions, and dimensional data are subject to correction or change without notice or incurring obligation. Download latest catalog page revisions at www.daman.com.

Ordering Information

Material	Valve Pattern	Product Type	Circuit	Port Threads																																				
<table border="1"> <thead> <tr> <th colspan="2">Material</th> </tr> </thead> <tbody> <tr> <td>A</td> <td>Aluminum - 6061-T6 3000[†] psi • 20.7 MPa</td> </tr> <tr> <td>D</td> <td>Ductile Iron - D4512 5000[†] psi • 34.5 MPa</td> </tr> <tr> <td colspan="2">[†] Working pressure should be considered in accordance with ISO 4413 to determine appropriate material type.</td> </tr> </tbody> </table>	Material		A	Aluminum - 6061-T6 3000 [†] psi • 20.7 MPa	D	Ductile Iron - D4512 5000 [†] psi • 34.5 MPa	[†] Working pressure should be considered in accordance with ISO 4413 to determine appropriate material type.		<table border="1"> <thead> <tr> <th colspan="2">Valve Pattern</th> </tr> </thead> <tbody> <tr> <td>D03</td> <td>ISO 4401-03-02 NFPA T3.5.1-D03 See Tech Infomation</td> </tr> </tbody> </table>	Valve Pattern		D03	ISO 4401-03-02 NFPA T3.5.1-D03 See Tech Infomation	<table border="1"> <thead> <tr> <th colspan="2">Product Type</th> </tr> </thead> <tbody> <tr> <td>TP</td> <td>Tapping Plate</td> </tr> </tbody> </table>	Product Type		TP	Tapping Plate	<table border="1"> <thead> <tr> <th colspan="2">Circuit</th> </tr> </thead> <tbody> <tr> <td>PT</td> <td>P and T ports provided</td> </tr> <tr> <td>AB</td> <td>A and B ports provided</td> </tr> <tr> <td>L</td> <td>L port provided</td> </tr> </tbody> </table>	Circuit		PT	P and T ports provided	AB	A and B ports provided	L	L port provided	<table border="1"> <thead> <tr> <th colspan="2">Port Threads</th> </tr> </thead> <tbody> <tr> <td>4P</td> <td>0.25-18 NPTF ANSI B1.20.3</td> </tr> <tr> <td>4S</td> <td>-4 SAE ISO 11926; SAE 1926</td> </tr> <tr> <td>4B</td> <td>0.25-19 BSPP ISO 1179; BS 2779</td> </tr> <tr> <td>4M</td> <td>M10 x 1.0 ISO 6149</td> </tr> <tr> <td>4T</td> <td>0.25-19 BSPT ISO 7; BS 21</td> </tr> </tbody> </table>	Port Threads		4P	0.25-18 NPTF ANSI B1.20.3	4S	-4 SAE ISO 11926; SAE 1926	4B	0.25-19 BSPP ISO 1179; BS 2779	4M	M10 x 1.0 ISO 6149	4T	0.25-19 BSPT ISO 7; BS 21
Material																																								
A	Aluminum - 6061-T6 3000 [†] psi • 20.7 MPa																																							
D	Ductile Iron - D4512 5000 [†] psi • 34.5 MPa																																							
[†] Working pressure should be considered in accordance with ISO 4413 to determine appropriate material type.																																								
Valve Pattern																																								
D03	ISO 4401-03-02 NFPA T3.5.1-D03 See Tech Infomation																																							
Product Type																																								
TP	Tapping Plate																																							
Circuit																																								
PT	P and T ports provided																																							
AB	A and B ports provided																																							
L	L port provided																																							
Port Threads																																								
4P	0.25-18 NPTF ANSI B1.20.3																																							
4S	-4 SAE ISO 11926; SAE 1926																																							
4B	0.25-19 BSPP ISO 1179; BS 2779																																							
4M	M10 x 1.0 ISO 6149																																							
4T	0.25-19 BSPT ISO 7; BS 21																																							

For **coating options** see pages 245-246.

D03 Tapping Plates

Orifice Tapping Plate

Tapping Plate hardware / interface seal kit is supplied. See page 180 for itemized list.

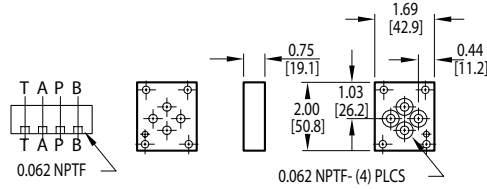

Spot Drilled Tapping Plate

Tapping Plate hardware / interface seal kit is supplied. See page 180 for itemized list.

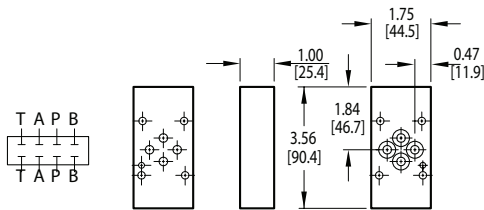

B to T vent Tapping Plate

Tapping Plate hardware / interface seal kit is supplied. See page 180 for itemized list.

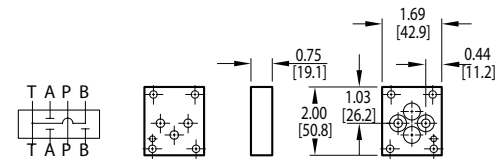

Specifications, descriptions, and dimensional data are subject to correction or change without notice or incurring obligation. Download latest catalog page revisions at www.daman.com.

Ordering Information

Material	Valve Pattern	Product Type	Circuit
----------	---------------	--------------	---------

For **coating options** see pages 245-246.

Material	
A	Aluminum - 6061-T6 3000† psi • 20.7 MPa
D	Ductile Iron - D4512 5000† psi • 34.5 MPa

† Working pressure should be considered in accordance with ISO 4413 to determine appropriate material type.

Product Type	
TP	Tapping Plate

Valve Pattern	
D03	ISO 4401-03-02 NFPA T3.5.1-D03 See Tech Information

Circuit	
SD	Spot drilled ports
OP	Orifice plate
BTV	B to T vent plate

D03 Tapping Plates

D03 Two Station Tapping Plate

A₁ common to A₂, B₁ common to B₂

Tapping Plate hardware / interface seal kit is supplied. See page 180 for itemized list.

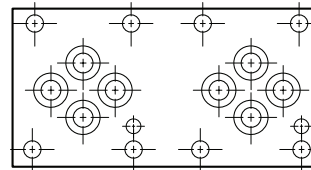
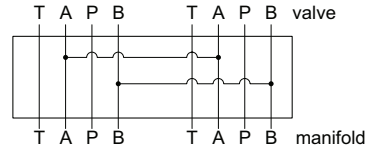
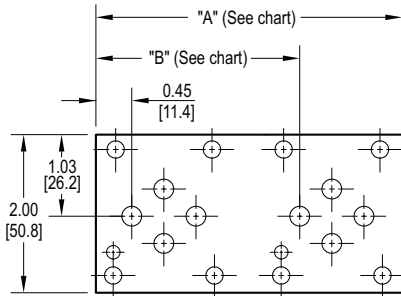

Dimension	A	B
*D03TP022AB	3.88 [98.6]	2.58 [65.5]
*D03TP024AB	5.75 [146.1]	4.45 [113.1]
L*D03TP022AB	3.75 [95.3]	2.45 [62.3]

There are two different tapping plate models with spacing code 2 available. This is necessary to cover the variation of valve spacing between the standard design and the LC (low cost) design of D03 manifolds. The standard manifold design has 2.125" valve spacing while the LC design has 2.000" valve spacing. An L is added to the front of the model number to denote the tapping plate designed to be used with the LC manifold. Note that a single model is required with spacing code 4 as both the standard and LC designs have 4.000 spacing.

Specifications, descriptions, and dimensional data are subject to correction or change without notice or incurring obligation. Download latest catalog page revisions at www.daman.com.

Ordering Information

For **coating options** see pages 245-246.

