

# Fluid Cooling Shell & Tube B / SB Series

## Performance Notes

- Young Touchstone thermal interchange
- Competitively priced
- 1/4" or 3/8" tubes available
- Water to water applications
- Sea water applications
- NPT, SAE O-Ring, SAE flange, or BSPP shell side connections available
- End bonnets removable for servicing
- Mounting feet included (may be rotated in 90° increments)



**Options**  
90/10 copper nickel cooling tubes, bronze end bonnets for sea water service and zinc anodes

## Ratings

**Maximum Operating Pressure - Shell Side**  
250 PSI

**Maximum Operating Pressure - Tube Side**  
150 PSI

**Maximum Operating Temperature**  
350°F

## Materials

- Tubes** Copper  
**Hubs & Tubesheets** Steel or brass  
**Shell** Steel or brass  
**Baffles** Brass  
**End Bonnets** Cast iron  
**Mounting Brackets** Steel  
**Gaskets** Nitrile rubber/cellulose fiber  
**Nameplate** Aluminum foil

## How to Order

<b>Model Series</b>	<b>Model Size Selected</b>	<b>Baffle Spacing</b>	<b>Tube Diameter Code</b>	<b>Tube Side Passes</b>	<b>Shell Material</b>	<b>Cooling Tube Material</b>	<b>End Bonnet Material</b>	<b>Zinc Anodes</b>	
SB SBF B BS BM BF BFM		A - 1.125 B - 2.25 C - 4.5 D - 9.0	4 - 1/4" 6 - 3/8"	O - One Pass T - Two Pass F - Four Pass	Blank - Steel BR - Brass	Blank - Copper CN - CuNi	Blank - Cast Iron B - Bronze	Blank - None Z - Zinc	

**ADD FOR B SERIES MODELS ONLY:**  
BR-CN-B-Z is to be used for all seawater/dirty water applications.

### Steel Hub

SB = NPT Shell Side, NPT Tube Side  
 SBF = SAE Flange (with UNC threads) Shell Side connections; NPT Tube Side connections

### Brass Hub

B = NPT Shell Side connections; NPT Tube Side connections  
 BS = SAE O-Ring Shell Side connections; NPT Tube Side connections  
 BM = BSPP Shell Side connections; BSPP Tube Side connections  
 BF = SAE Flange (with UNC threads) Shell Side connections; NPT Tube Side connections  
 BFM = SAE Flange (with Metric threads) Shell Side connections; BSPP Tube Side connections

SAE flanges available on some models. Consult factory for details.

# Dimensions

## One Pass

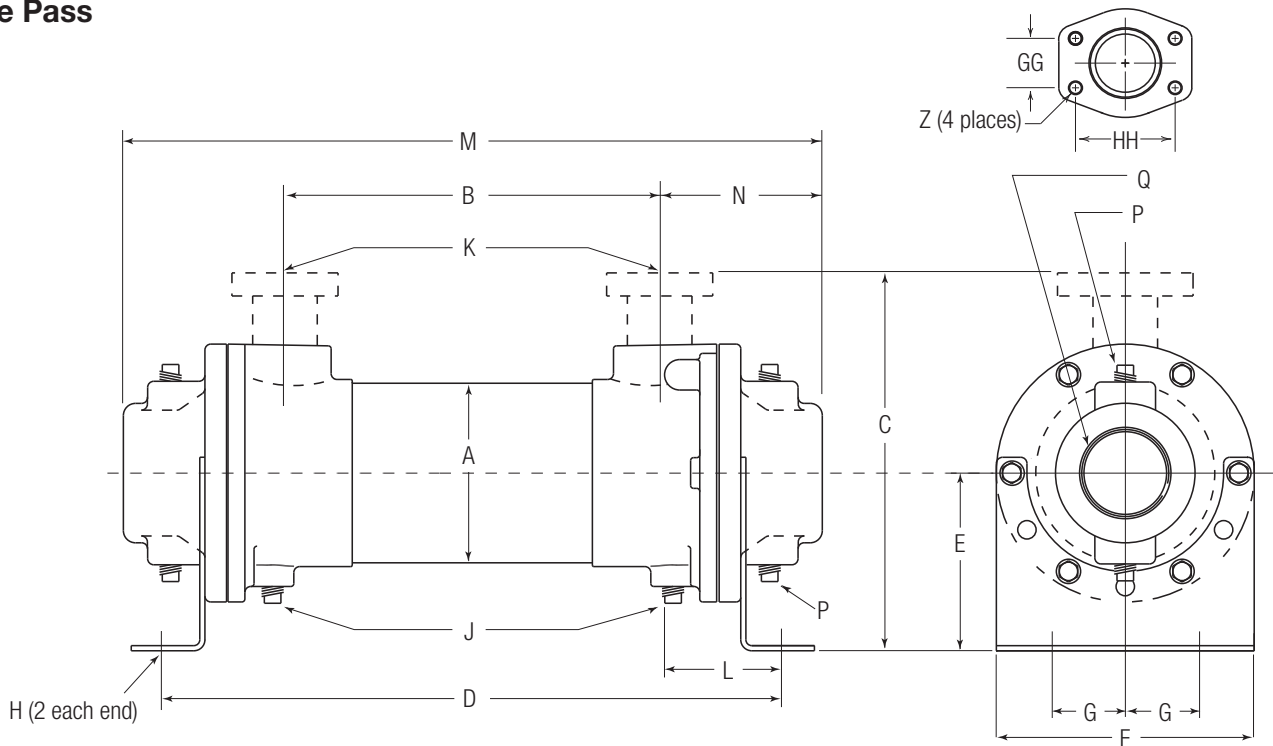

Flange Size	GG	HH	Z - CF	Z - CFM
1	1.03	2.06	3/8-16 UNC	M-10
1.50	1.41	2.75	1/2-13 UNC	M-12
2	1.69	3.06	1/2-13 UNC	M-12
3	2.44	4.19	5/8-11 UNC	M-16

Model	A	B	C		D	E	F	G	H	J NPT	K		L	M	N	P NPT	Q NPT
			NPT/BSPP SAE O-Ring	SAE Flange							NPT/BSPP Flange	SAE O-Ring					
B-401	2.125	7.62	3.50	—	11.01	1.94	2.62	.88	.41 Dia.	—	*.50	#8, 3/4-16 UNF-2B	1.72	11.24	1.81	—	1.00
B-402	2.125	16.62	3.50	—	20.01	1.94	2.62	.88	.41 Dia.	—	*.50	#8, 3/4-16 UNF-2B	1.72	20.24	1.81	—	1.00
B-701	3.656	7.00	6.25	C/F	12.01	3.62	5.25	1.50	.44 x 1.00	(2) .38	1.00	#16 1 1/16-12 UNF-2B	2.69	13.64	3.24	(4) .38	1.50
B-702	3.656	16.00	6.25	C/F	21.01	3.62	5.25	1.50	.44 x 1.00	(2) .38	1.00	#16 1 1/16-12 UNF-2B	2.69	22.64	3.24	(4) .38	1.50
B-703	3.656	25.00	6.25	C/F	30.01	3.62	5.25	1.50	.44 x 1.00	(2) .38	1.00	#16 1 1/16-12 UNF-2B	2.69	31.64	3.24	(4) .38	1.50
B-1002	5.125	15.50	7.38	8.46	21.71	4.00	6.75	2.00	.44 x 1.00	(6) .38	1.50	#24 1 7/8-12 UN-2B	3.06	23.60	4.05	(4) .38	2.00
B-1003	5.125	24.50	7.38	8.46	30.71	4.00	6.75	2.00	.44 x 1.00	(6) .38	1.50	#24 1 7/8-12 UN-2B	3.06	32.60	4.05	(4) .38	2.00
B-1004	5.125	33.50	7.38	8.46	39.71	4.00	6.75	2.00	.44 x 1.00	(6) .38	1.50	#24 1 7/8-12 UN-2B	3.06	41.60	4.05	(4) .38	2.00
B-1202	6.125	14.62	8.81	10.50	21.50	4.75	7.50	2.50	.44 x .88	(6) .38	2.00	#32 2 1/2-12 UN-2B	3.44	24.38	4.88	(4) .50	3.00
B-1203	6.125	23.50	8.81	10.50	30.38	4.75	7.50	2.50	.44 x .88	(6) .38	2.00	#32 2 1/2-12 UN-2B	3.44	33.25	4.88	(4) .50	3.00
B-1204	6.125	32.38	8.81	10.50	39.25	4.75	7.50	2.50	.44 x .88	(6) .38	2.00	#32 2 1/2-12 UN-2B	3.44	42.12	4.88	(4) .50	3.00
B-1205	6.125	41.38	8.81	10.50	48.25	4.75	7.50	2.50	.44 x .88	(6) .38	2.00	#32 2 1/2-12 UN-2B	3.44	51.12	4.88	(4) .50	3.00
B-1206	6.125	50.50	8.81	10.50	57.38	4.75	7.50	2.50	.44 x .88	(6) .38	2.00	#32 2 1/2-12 UN-2B	3.44	60.25	4.88	(4) .50	3.00
B-1207	6.125	59.50	8.81	10.50	66.38	4.75	7.50	2.50	.44 x .88	(6) .38	2.00	#32 2 1/2-12 UN-2B	3.44	69.25	4.88	(4) .50	3.00
B-1208	6.125	38.38	8.81	10.50	75.25	4.75	7.50	2.50	.44 x .88	(6) .38	2.00	#32 2 1/2-12 UN-2B	3.44	78.12	4.88	(4) .50	3.00
B-1602	8.00	13.60	12.13	15.61	22.38	6.50	8.62	3.50	.44 x 1.00	(6) .38	3.00	—	4.39	26.62	6.52	(4) .50	4.00
B-1603	8.00	22.60	12.13	15.61	31.38	6.50	8.62	3.50	.44 x 1.00	(6) .38	3.00	—	4.39	35.62	6.52	(4) .50	4.00
B-1604	8.00	31.60	12.13	15.61	40.38	6.50	8.62	3.50	.44 x 1.00	(6) .38	3.00	—	4.39	44.62	6.52	(4) .50	4.00
B-1605	8.00	40.60	12.13	15.61	49.38	6.50	8.62	3.50	.44 x 1.00	(6) .38	3.00	—	4.39	53.62	6.52	(4) .50	4.00
B-1606	8.00	49.60	12.13	15.61	58.38	6.50	8.62	3.50	.44 x 1.00	(6) .38	3.00	—	4.39	62.62	6.52	(4) .50	4.00
B-1607	8.00	58.60	12.13	15.61	67.38	6.50	8.62	3.50	.44 x 1.00	(6) .38	3.00	—	4.39	71.62	6.52	(4) .50	4.00
B-1608	8.00	67.60	12.13	15.61	76.38	6.50	8.62	3.50	.44 x 1.00	(6) .38	3.00	—	4.39	80.62	6.52	(4) .50	4.00
B-1609	8.00	76.60	12.13	15.61	85.38	6.50	8.62	3.50	.44 x 1.00	(6) .38	3.00	—	4.39	89.62	6.52	(4) .50	4.00
B-1610	8.00	85.60	12.13	15.61	94.38	6.50	8.62	3.50	.44 x 1.00	(6) .38	3.00	—	4.39	98.62	6.52	(4) .50	4.00

\*B-401 and B-402 SAE Flange not available. NOTE: We reserve the right to make reasonable design changes without notice. Consult factory. All dimensions are inches.

# Dimensions

## Two Pass

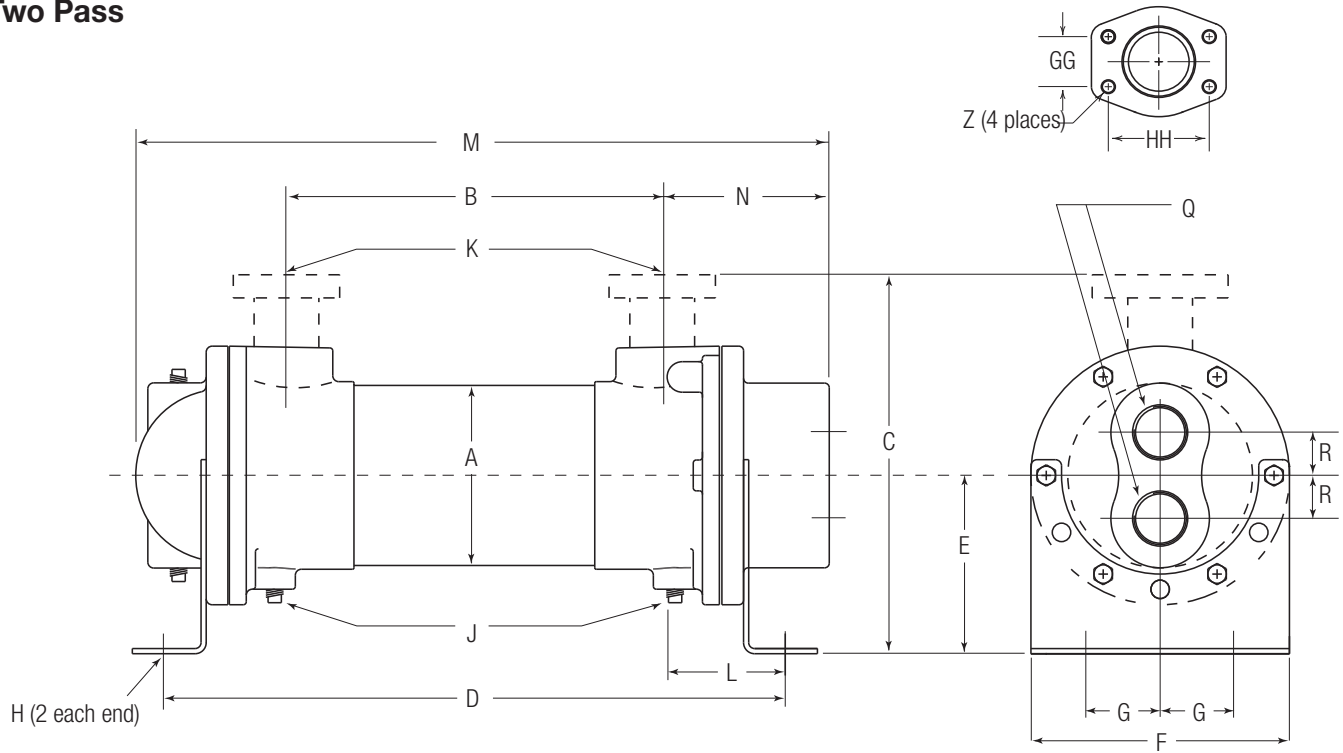

Flange Size	GG	HH	Z - CF	Z - CFM
1	1.03	2.06	3/8-16 UNC	M-10
1.50	1.41	2.75	1/2-13 UNC	M-12
2	1.69	3.06	1/2-13 UNC	M-12
3	2.44	4.19	5/8-11 UNC	M-16

Model	A	B	C		D	E	F	G	H	J NPT	K		L	M	N	P NPT	Q NPT	R
			NPT/BSPP SAE O-Ring	SAE Flange							NPT/BSPP Flange	SAE O-Ring						
B-701	3.656	7.00	6.25	C/F	12.01	3.62	5.25	1.50	.44 x 1.00	(2) .38	1.00	#16	2.69	13.28	3.30	(2) .38	1.00	.88
B-702	3.656	16.00	6.25	C/F	21.01	3.62	5.25	1.50	.44 x 1.00	(2) .38	1.00	1 1/16-12 UNF-2B	2.69	22.28	3.30	(2) .38	1.00	.88
B-703	3.656	25.00	6.25	C/F	30.01	3.62	5.25	1.50	.44 x 1.00	(2) .38	1.00	UNF-2B	2.69	31.28	3.30	(2) .38	1.00	.88
B-1002	5.125	15.50	7.38	8.46	21.71	4.00	6.75	2.00	.44 x 1.00	(6) .38	1.50	#24	3.06	23.29	3.80	(2) .38	1.50	1.19
B-1003	5.125	24.50	7.38	8.46	30.71	4.00	6.75	2.00	.44 x 1.00	(6) .38	1.50	1 1/8-12 UN-2B	3.06	32.29	3.80	(2) .38	1.50	1.19
B-1004	5.125	33.50	7.38	8.46	39.71	4.00	6.75	2.00	.44 x 1.00	(6) .38	1.50	UN-2B	3.06	41.29	3.80	(2) .38	1.50	1.19
B-1202	6.125	14.62	8.81	10.50	21.50	4.75	7.50	2.50	.44 x .88	(6) .38	2.00	#32 2 1/2-12 UN-2B	3.44	23.94	4.56	(2) .50	2.00	1.44
B-1203	6.125	23.50	8.81	10.50	30.38	4.75	7.50	2.50	.44 x .88	(6) .38	2.00		3.44	32.81	4.56	(2) .50	2.00	1.44
B-1204	6.125	32.38	8.81	10.50	39.25	4.75	7.50	2.50	.44 x .88	(6) .38	2.00		3.44	41.69	4.56	(2) .50	2.00	1.44
B-1205	6.125	41.38	8.81	10.50	48.25	4.75	7.50	2.50	.44 x .88	(6) .38	2.00		3.44	50.69	4.56	(2) .50	2.00	1.44
B-1206	6.125	50.50	8.81	10.50	57.38	4.75	7.50	2.50	.44 x .88	(6) .38	2.00		3.44	59.81	4.56	(2) .50	2.00	1.44
B-1207	6.125	59.50	8.81	10.50	66.38	4.75	7.50	2.50	.44 x .88	(6) .38	2.00		3.44	68.81	4.56	(2) .50	2.00	1.44
B-1208	6.125	38.38	8.81	10.50	75.25	4.75	7.50	2.50	.44 x .88	(6) .38	2.00		3.44	77.69	4.56	(2) .50	2.00	1.44
B-1602	8.00	13.60	12.13	15.61	22.38	6.50	8.62	3.50	.44 x 1.00	(6) .38	3.00		—	4.39	25.10	6.08	(2) .50	2.50
B-1603	8.00	22.60	12.13	15.61	31.38	6.50	8.62	3.50	.44 x 1.00	(6) .38	3.00	—	4.39	34.10	6.08	(2) .50	2.50	1.88
B-1604	8.00	31.60	12.13	15.61	40.38	6.50	8.62	3.50	.44 x 1.00	(6) .38	3.00	—	4.39	43.10	6.08	(2) .50	2.50	1.88
B-1605	8.00	40.60	12.13	15.61	49.38	6.50	8.62	3.50	.44 x 1.00	(6) .38	3.00	—	4.39	52.10	6.08	(2) .50	2.50	1.88
B-1606	8.00	49.60	12.13	15.61	58.38	6.50	8.62	3.50	.44 x 1.00	(6) .38	3.00	—	4.39	61.10	6.08	(2) .50	2.50	1.88
B-1607	8.00	58.60	12.13	15.61	67.38	6.50	8.62	3.50	.44 x 1.00	(6) .38	3.00	—	4.39	70.10	6.08	(2) .50	2.50	1.88
B-1608	8.00	67.60	12.13	15.61	76.38	6.50	8.62	3.50	.44 x 1.00	(6) .38	3.00	—	4.39	79.10	6.08	(2) .50	2.50	1.88
B-1609	8.00	76.60	12.13	15.61	85.38	6.50	8.62	3.50	.44 x 1.00	(6) .38	3.00	—	4.39	88.10	6.08	(2) .50	2.05	1.88
B-1610	8.00	85.60	12.13	15.61	94.38	6.50	8.62	3.50	.44 x 1.00	(6) .38	3.00	—	4.39	97.10	6.08	(2) .50	2.50	1.88

NOTE: We reserve the right to make reasonable design changes without notice. Consult factory. All dimensions are inches.

# Dimensions

## Four Pass

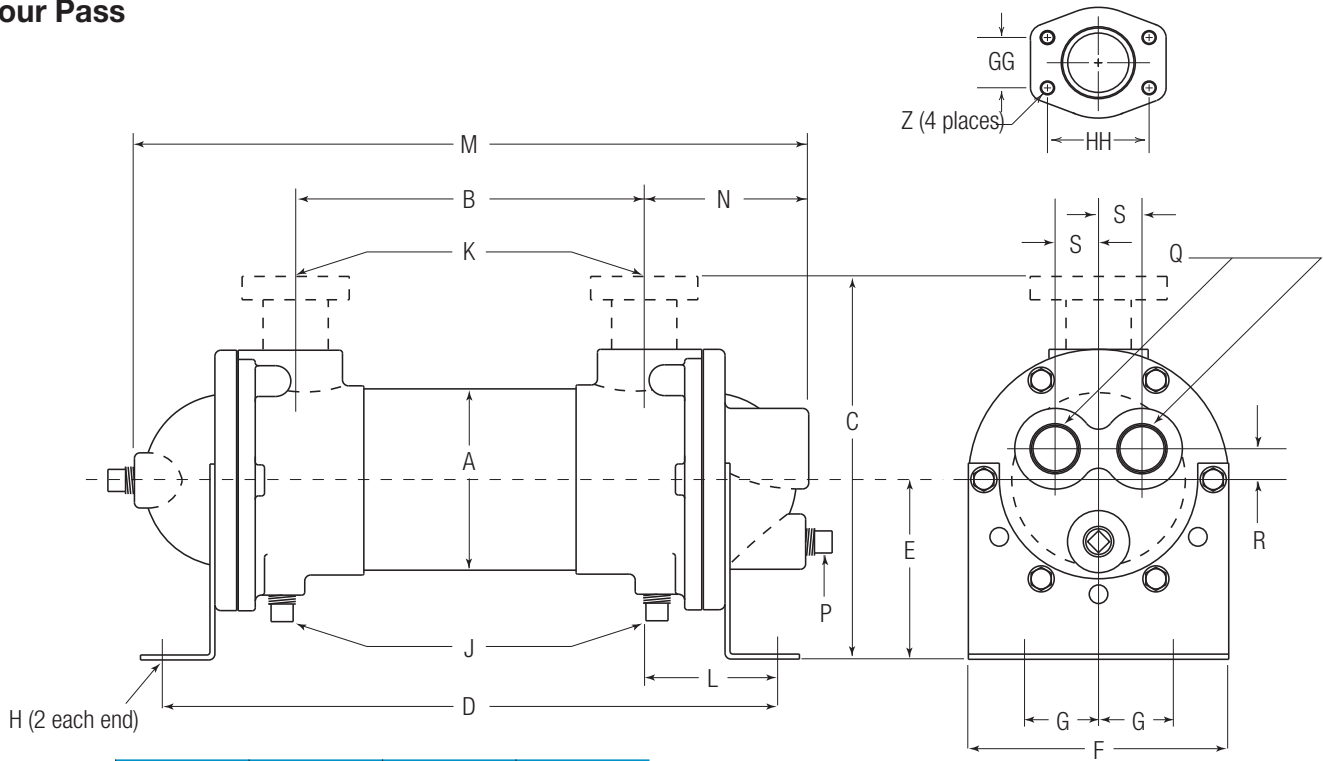

Flange Size	GG	HH	Z - CF	Z - CFM
1	1.03	2.06	3/8-16 UNC	M-10
1.50	1.41	2.75	1/2-13 UNC	M-12
2	1.69	3.06	1/2-13 UNC	M-12
3	2.44	4.19	5/8-11 UNC	M-16

Model	A	B	C		D	E	F	G	H	J NPT	K		L	M	N	P NPT	Q NPT	R	S
			NPT/BSPP SAE O-Ring	SAE Flange							NPT/BSPP Flange	SAE O-Ring							
B-701	3.656	7.00	6.25	C/F	12.01	3.62	5.25	1.50	.44 x 1.00	(2) .38	1.00	#16	2.69	13.57	3.32	(3) .38	.75	.62	.88
B-702	3.656	16.00	6.25	C/F	21.01	3.62	5.25	1.50	.44 x 1.00	(2) .38	1.00	1 1/16-12 UNF-2B	2.69	22.57	3.32	(3) .38	.75	.62	.88
B-703	3.656	25.00	6.25	C/F	30.01	3.62	5.25	1.50	.44 x 1.00	(2) .38	1.00	UNF-2B	2.69	31.57	3.32	(3) .38	.75	.62	.88
B-1002	5.125	15.50	7.38	8.46	21.71	4.00	6.75	2.00	.44 x 1.00	(6) .38	1.50	#24	3.06	23.57	4.12	(3) .38	1.00	.75	1.34
B-1003	5.125	24.50	7.38	8.46	30.71	4.00	6.75	2.00	.44 x 1.00	(6) .38	1.50	1 1/8-12 UN-2B	3.06	32.57	4.12	(3) .38	1.00	.75	1.34
B-1004	5.125	33.50	7.38	8.46	39.71	4.00	6.75	2.00	.44 x 1.00	(6) .38	1.50	UN-2B	3.06	41.57	4.12	(3) .38	1.00	.75	1.34
B-1202	6.125	14.62	8.81	10.50	21.50	4.75	7.50	2.50	.44 x .88	(6) .38	2.00	#32 2 1/2-12 UN-2B	3.44	24.44	4.90	(2) .38	1.50	1.06	1.40
B-1203	6.125	23.50	8.81	10.50	30.38	4.75	7.50	2.50	.44 x .88	(6) .38	2.00		3.44	33.31	4.90	(2) .38	1.50	1.06	1.40
B-1204	6.125	32.38	8.81	10.50	39.25	4.75	7.50	2.50	.44 x .88	(6) .38	2.00		3.44	42.19	4.90	(2) .38	1.50	1.06	1.40
B-1205	6.125	41.88	8.81	10.50	48.25	4.75	7.50	2.50	.44 x .88	(6) .38	2.00		3.44	51.19	4.90	(1) .50	1.50	1.06	1.40
B-1206	6.125	50.50	8.81	10.50	57.38	4.75	7.50	2.50	.44 x .88	(6) .38	2.00		3.44	60.31	4.90	(1) .50	1.50	1.06	1.40
B-1207	6.125	59.50	8.81	10.50	66.38	4.75	7.50	2.50	.44 x .88	(6) .38	2.00		3.44	69.31	4.90	(1) .50	1.50	1.06	1.40
B-1208	6.125	38.38	8.81	10.50	75.25	4.75	7.50	2.50	.44 x .88	(6) .38	2.00		3.44	78.19	4.90	(1) .50	1.50	1.06	1.40
B-1602	8.00	13.60	12.13	15.61	22.38	6.50	8.62	3.50	.44 x 1.00	(6) .38	3.00		—	4.39	26.72	6.48	(3) .50	2.00	1.88
B-1603	8.00	22.60	12.13	15.61	31.88	6.50	8.62	3.50	.44 x 1.00	(6) .38	3.00	—	4.39	35.72	6.48	(3) .50	2.00	1.88	1.88
B-1604	8.00	31.60	12.13	15.61	40.38	6.50	8.62	3.50	.44 x 1.00	(6) .38	3.00	—	4.39	44.72	6.48	(3) .50	2.00	1.88	1.88
B-1605	8.00	40.60	12.13	15.61	49.38	6.50	8.62	3.50	.44 x 1.00	(6) .38	3.00	—	4.39	53.72	6.48	(3) .50	2.00	1.88	1.88
B-1606	8.00	49.60	12.13	15.61	58.38	6.50	8.62	3.50	.44 x 1.00	(6) .38	3.00	—	4.39	62.72	6.48	(3) .50	2.00	1.88	1.88
B-1607	8.00	58.60	12.13	15.61	67.38	6.50	8.62	3.50	.44 x 1.00	(6) .38	3.00	—	4.39	71.72	6.48	(3) .50	2.00	1.88	1.88
B-1608	8.00	67.60	12.13	15.61	76.38	6.50	8.62	3.50	.44 x 1.00	(6) .38	3.00	—	4.39	80.72	6.48	(3) .50	2.00	1.88	1.88
B-1609	8.00	76.60	12.13	15.61	85.38	6.50	8.62	3.50	.44 x 1.00	(6) .38	3.00	—	4.39	89.72	6.48	(3) .50	2.00	1.88	1.88
B-1610	8.00	85.60	12.13	15.61	94.38	6.50	8.62	3.50	.44 x 1.00	(6) .38	3.00	—	4.39	98.72	6.48	(3) .50	2.00	1.88	1.88

NOTE: We reserve the right to make reasonable design changes without notice. Consult factory. All dimensions are inches.

# Performance Curves

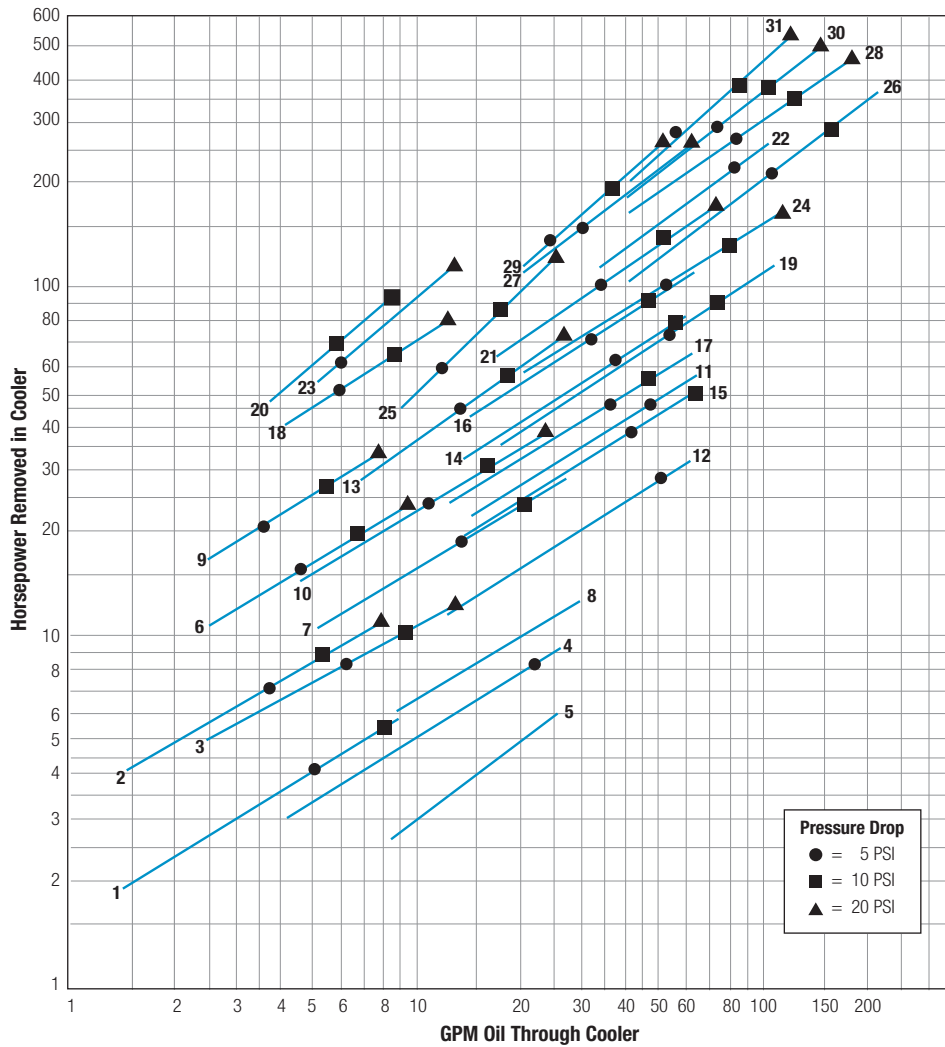

Curve Number	Model	Shipping Weight (LBS)
1	B-401-A4-0	7
2	B-402-A4-0	10
3	B-701-A4-T	23
4	B-701-B6-F	23
5	B-701-C6-T	23
6	B-702-A4-T	28
7	B-702-B4-F	28
8	B-702-C6-T	28
9	B-703-A4-T	35
10	B-703-B4-F	35
11	B-1002-C4-T	49
12	B-1002-C6-T	49
13	B-1003-B4-F	65
14	B-1003-C4-T	65
15	B-1003-C6-T	65
16	B-1004-C4-T	72
17	B-1004-C6-T	72
18	B-1202-A4-F	72
19	B-1202-C4-F	72
20	B-1204-A4-F	110
21	B-1204-C4-F	110
22	B-1206-D4-F	160
23	B-1602-A4-F	145
24	B-1602-C4-F	145
25	B-1604-B4-F	195
26	B-1604-D4-F	195
27	B-1606-C4-F	259
28	B-1606-D4-F	259
29	B-1608-C4-F	310
30	B-1608-D4-F	310
31	B-1610-D4-F	400

Shipping weights are approximate.

## Maximum Flow Rates

Example Model No.  
**B - 1003 - C4 - F**

Unit Size	Shell Side (GPM)		Baffle Spacing		Tube Side (GPM)		
	A	B	C	D	O	T	F
400	9.6	—	—	—	25	—	—
700	17	29	29	—	61	31	15
1000	24	48	69	69	146	73	37
1200	29	57	115	115	224	112	56
1600	37	74	149	253	363	181	91

**Caution:** Incorrect installation can cause this product to fail prematurely, causing the shell side and tube side fluids to intermix.

## Piping Diagram

### One Pass

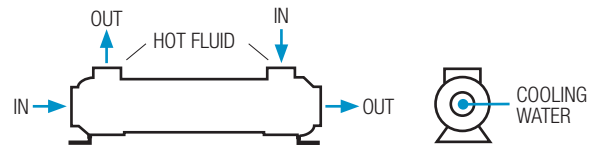

### Two and Four Pass

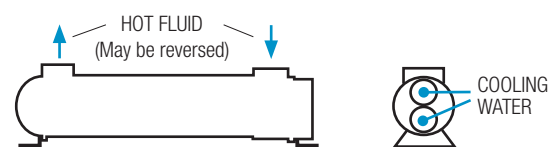

Specific applications may have different piping arrangements. Contact factory for assistance.

# Selection Procedure

Performance Curves are based on 100SSU oil leaving the cooler 40°F higher than the water temperature used for cooling. This is also referred to as a 40°F approach temperature. Curves are based on a 2:1 oil to water flow ratio. Curves are 1:1.

**STEP 1 Determine the Heat Load.** This will vary with different systems, but typically coolers are sized to remove 25 to 50% of the input nameplate horsepower. (Example: 100 HP Power Unit x .33 = 33 HP Heat load.)  
If BTU/HR is known:  $HP = \frac{BTU/HR}{2545}$

**STEP 2 Determine Approach Temperature.** Desired oil leaving cooler °F – Water Inlet temp. °F = Actual Approach (Max. reservoir temp.)

**STEP 3 Determine Curve Horsepower Heat Load.** Enter the information from above:  
Horsepower heat load x  $\frac{40}{\text{Actual Approach}}$  x  $\frac{\text{Viscosity}}{\text{Correction A}}$  = Curve Horsepower

**STEP 4 Enter curves** at oil flow through cooler and curve horsepower. Any curve above the intersecting point will work.

**STEP 5 Determine Oil Pressure Drop from Curves:**  
● = 5 PSI   ■ = 10 PSI   ▲ = 20 PSI   Multiply pressure drop from curve by correction factor B found on oil viscosity correction curve.

## Oil Temperature

Oil coolers can be selected using entering or leaving oil temperatures.

Typical operating temperature ranges are:

Hydraulic Oil	110°F - 130°F
Hydrostatic Drive Oil	130°F - 180°F
Bearing Lube Oil	120°F - 160°F
Lube Oil Circuits	110°F - 130°F

## Desired Reservoir Temperature

**Return Line Cooling:** Desired temperature is the oil temperature leaving the cooler. This will be the same temperature that will be found in the reservoir.

**Off-Line Recirculation Cooling Loop:** Desired temperature is the oil temperature *entering* the cooler. In this case, the oil temperature change must be determined so that the actual oil leaving temperature can be found. Calculate the oil temperature change (Oil ΔT) with this formula:

$$\text{Oil } \Delta T = (\text{BTUs/HR}) / (\text{GPM Oil Flow} \times 210).$$

To calculate the oil leaving temperature from the cooler, use this formula:

$$\text{Oil Leaving Temp.} = \text{Oil Entering Temp} - \text{Oil } \Delta T.$$

This formula may also be used in any application where the only temperature available is the entering oil temperature.

**Oil Pressure Drop:** Most systems can tolerate a pressure drop through the heat exchanger of 20 to 30 PSI. Excessive pressure drop should be avoided. Care should be taken to limit pressure drop to 5 PSI or less for case drain applications where high back pressure may damage the pump shaft seals.

## Viscosity Correction

