

Fluid Cooling P-BAR ■ Industrial BOL Series

BRAZED ALUMINUM CONSTRUCTION

Performance Notes

- Bar and plate brazed aluminum core
- Provides the best heat transfer per given envelope size while minimizing pressure drop
- Air-side fin design minimizes fouling and static pressure ensuring long-term, reliable performance
- Welded fittings/ports and manifolds ensure structural integrity
- Standard SAE ports – NPT & BSPP available
- Customized units are available to meet your OE specific performance requirements
- T-BAR core optional for high viscosity oils or other highly fouling fluids. (See T-BAR Performance Curve)
- Optional internal temperature controlled bypass (T-BAR)

Ratings

Maximum Operating Pressure
250 PSI (17 BAR)

Maximum Operating Temperature
300°F (150°C)

Fluid Compatibility

- Petroleum/mineral oils
- Oil/water emulsion
- Water/ethylene glycol



Options

- Low noise
- T-BAR core
- Serviceable internal pressure and temperature bypass

Materials

Mounting Feet Steel

Standard Core Brazed aluminum bar and plate

- Tanks – 5052 Aluminum
- Nose Bar & Little Bar – 3003-H Aluminum
- Air Fin, Plate, Turbulator & End Plate – 3003-0 Aluminum

Fanguard Steel

Connectors Aluminum

Fan Aluminum Hub, Plastic Blades

Shroud Steel

Motor TEFC & IEC

Internal Bypass Options

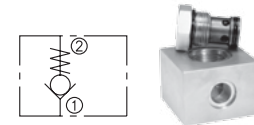

Pressure Bypass

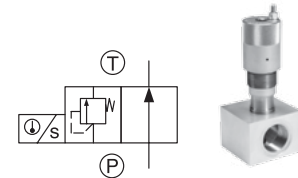

Temperature Controlled Bypass with Integrated Pressure Relief

How to Order

[]	-	[]	-	[]	-	[]	-	[]	-	[]	
Model Series BOL BOLR - Internal pressure bypass included		Model Size Selected 4 • 8 • 16* • 30 400* • 725* • 950 1200* • 1600* • 2000		Connection Type 1 - NPT 2 - SAE 3 - BSPP		Bypass* Blank - No Bypass Pressure bypass only (P-BAR and T-BAR Cores) 25 - 25 PSI (1.7 BAR) 60 - 60 PSI (4.1 BAR) Thermal/pressure relief bypass with temperature rating of 140°F (60°C) (T-BAR Core only) 29 - 29 PSI (2.0 BAR) 87 - 87 PSI (6.0 BAR) 130 - 130 PSI (9.0 BAR)		Specify Motor Required 2 - Single Phase 3 - Three Phase 6 - 575V Three Phase 9 - Hydraulic 18 - IEC Three Phase C - Core Only 0 - No Motor		Core Blank - Standard P-BAR TB - T-BAR Core**	Noise Level Blank - Standard Noise Level LN - Low Noise Level***

*BOL-4 is not offered with bypass.

This is a partial flow pressure bypass only. It is not designed to be a full flow system bypass.

** T-BAR core option provides a T-BAR core in a BOL frame. Used for high fouling or high viscosity fluids. Performance is typically 15-25% less than the P-BAR Core. Consult Factory for details.

***Available in models 8-2000 only, the low noise option is done by lowering the fan speed. As a result, the performance will be reduced by approximately one model size.

Dimensions

BOL-4

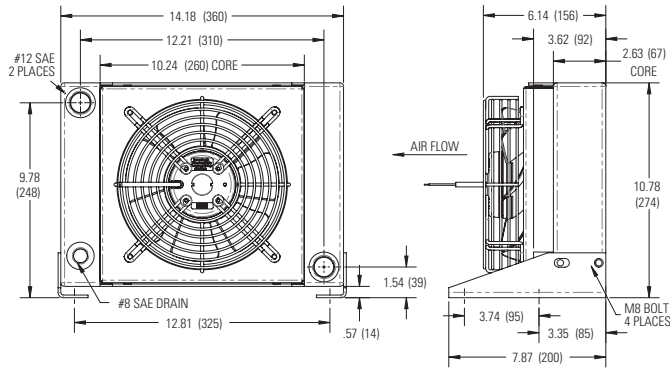

BOL-8 through BOL-1600

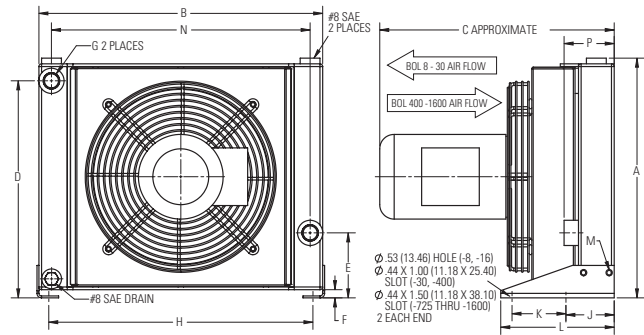

BOL-2000

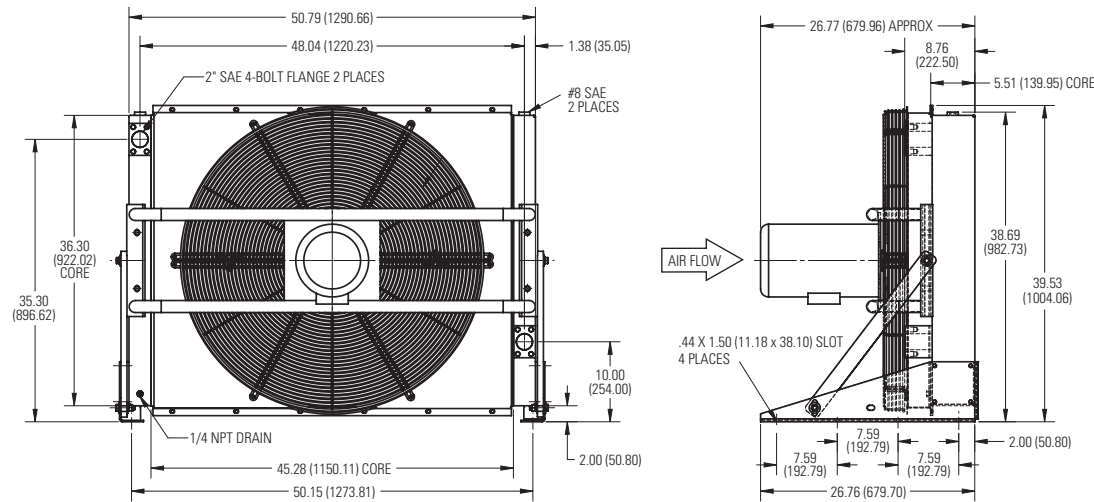

Model	A	B	C	D	E	F	G		H	J	K	L	M	N	P	Approx. Shipping Weight LBS (KG)
							SAE	NPT & BSPP								
BOL-4	See diagram above						#12 SAE	3/4"	See diagram above						18 (8.16)	
BOL-8	12.56 (319)	15.81 (402)	15.94 (405)	11.34 (288)	4.51 (115)	0.57 (14)	#12 SAE	3/4"	14.44 (361)	3.36 (85)	3.74 (95)	7.87 (200)	M8 BOLT (2PL)	13.99 (355)	3.63 (92)	45 (20.4)
BOL-16	16.33 (415)	19.69 (500)	16.43 (417)	15.06 (383)	4.57 (116)	0.57 (14)	#12 SAE	3/4"	18.31 (465)	3.35 (85)	3.74 (95)	7.87 (200)	M8 BOLT (2PL)	17.95 (456)	3.63 (92)	55 (24.94)
BOL-30	20.13 (511)	26.38 (670)	17.88 (454)	19.49 (495)	5.26 (134)	1.32 (340)	#20 SAE	1 1/4"	24.74 (628)	4.15 (105)	5.00 (127)	9.9 (251)	M8 BOLT (4PL)	24.34 (618)	5.00 (127)	125 (56.70)
BOL-400	18.90 (480)	22.38 (568)	18.6 (472)	17.31 (440)	6.50 (165)	2.00 (51)	#20 SAE	1 1/4"	22.31 (567)	4.15 (105)	5.00 (127)	9.9 (251)	M8 BOLT (4PL)	20.07 (510)	5.00 (127)	148 (67.13)
BOL-725	23.40 (594)	30.25 (768)	17.56 (446)	21.62 (549)	6.50 (165)	2.00 (51)	#20 SAE	1 1/4"	30.11 (765)	4.15 (105)	5.00 (127)	9.9 (251)	M10 BOLT (4PL)	27.95 (710)	5.00 (127)	170 (77.11)
BOL-950	27.70 (705)	37.01 (940)	22.68 (576)	24.55 (624)	9.50 (241)	2.00 (51)	2" SAE 4 BOLT FLANGE	2"	35.87 (911)	6.05 (154)	9.20 (234)	16 (406)	M10 BOLT (4PL)	34.26 (9870)	7.00 (178)	300 (136.08)
BOL-1200	28.38 (721)	40.98 (1041)	24.05 (611)	24.55 (624)	5.50 (140)	2.00 (51)		2"	40.29 (1023)	6.05 (154)	9.20 (234)	16 (406)	M10 BOLT (4PL)	38.18 (970)	8.75 (222)	430 (195.04)
BOL-1600	36.50 (927)	40.98 (1041)	25.43 (646)	32.80 (833)	9.50 (241)	2.00 (51)		2"	40.29 (1023)	6.05 (154)	9.20 (234)	16 (406)	M10 BOLT (4PL)	38.18 (970)	8.75 (222)	515 (233.60)
BOL-2000	See diagram above							2"	See diagram above						582 (264.00)	

Note: We reserve the right to make reasonable design changes without notice. All dimensions are in inches (millimeters) unless noted otherwise.

Dimensions with Internal Pressure Bypass

BOLR-8 – BOLR-1600

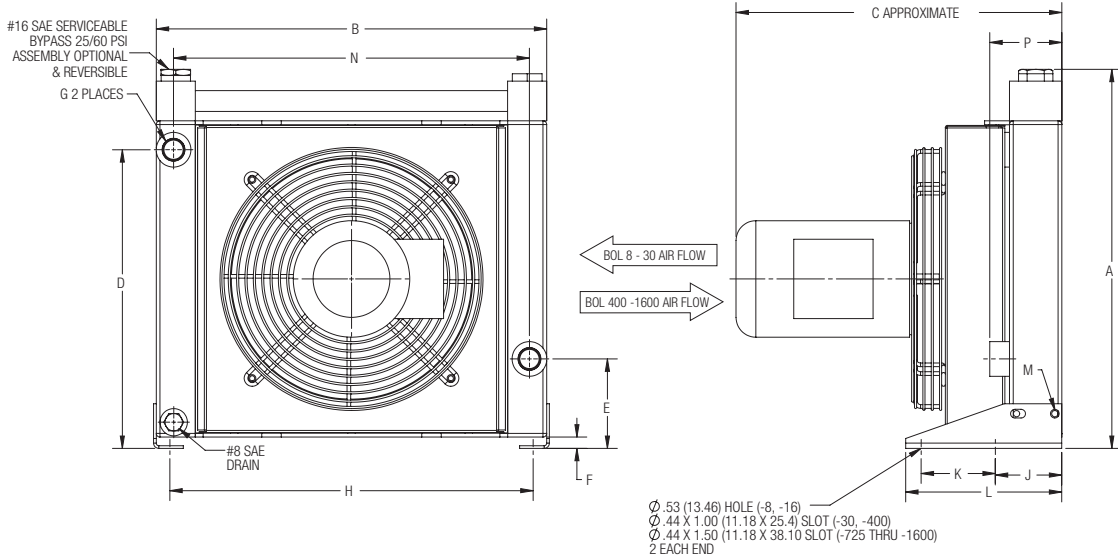

BOLR-2000

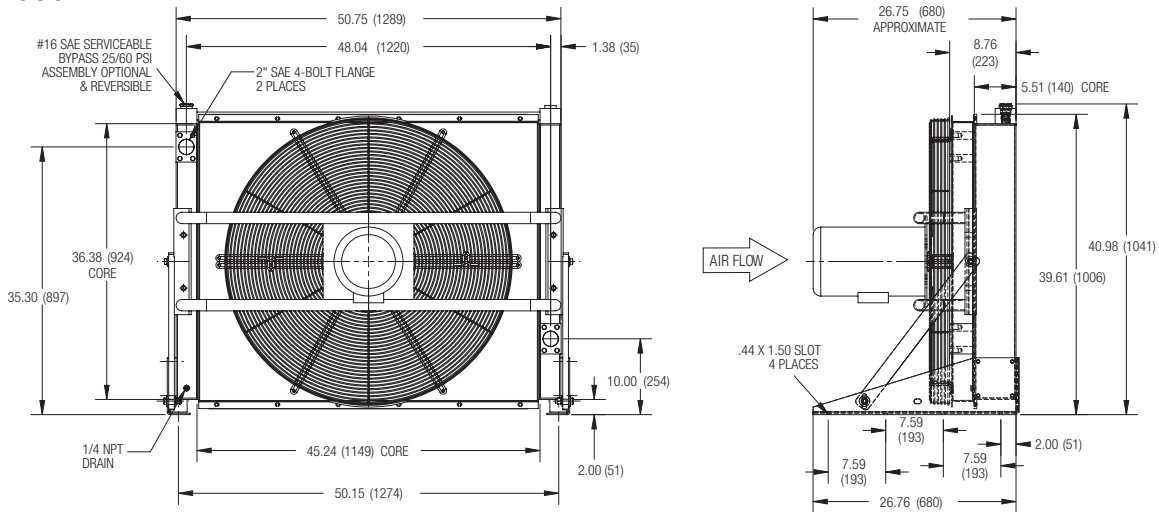

Model	A	B	C	D	E	F	G		H	J	K	L	M	N	P	Approx. Ship Weight LBS (KG)
							SAE	NPT & BSPP								
BOLR-8	15.34 (390)	15.81 (402)	15.94 (405)	11.34 (288)	4.51 (115)	0.57 (14)	#12 SAE	3/4"	14.44 (361)	3.36 (85)	3.74 (95)	7.87 (200)	M8 Bolt (2PL)	13.99 (355)	3.63 (92)	60 (27.22)
BOLR-16	19.11 (485)	19.69 (500)	16.43 (417)	15.06 (383)	4.57 (116)	0.57 (14)	#12 SAE	3/4"	18.31 (465)	3.35 (85)	3.74 (95)	7.87 (200)	M8 Bolt (2PL)	17.95 (456)	3.63 (92)	70 (31.75)
BOLR-30	23.66 (601)	26.38 (670)	17.88 (454)	19.49 (495)	5.26 (134)	1.32 (340)	#20 SAE	1 1/4"	24.74 (628)	4.15 (105)	5.00 (127)	9.9 (251)	M8 Bolt (4PL)	24.34 (618)	5.00 (127)	140 (63.50)
BOLR-400	21.49 (546)	22.38 (568)	18.6 (472)	17.31 (440)	6.50 (165)	2.00 (51)	#20 SAE	1 1/4"	22.31 (567)	4.15 (105)	5.00 (127)	9.9 (251)	M8 Bolt (4PL)	20.07 (510)	5.00 (127)	162 (73.48)
BOLR-725	25.82 (656)	30.25 (768)	17.56 (446)	21.62 (549)	6.50 (165)	2.00 (51)	#20 SAE	1 1/4"	30.11 (765)	4.15 (105)	5.00 (127)	9.9 (251)	M10 Bolt (4PL)	27.95 (710)	5.00 (127)	185 (83.92)
BOLR-950	30.15 (766)	37.01 (940)	22.68 (576)	24.55 (624)	9.50 (241)	2.00 (51)	2" SAE 4 BOLT FLANGE	2"	35.87 (911)	6.05 (154)	9.20 (234)	16 (406)	M10 Bolt (4PL)	34.26 (9870)	7.00 (178)	315 (142.88)
BOLR-1200	30.15 (766)	40.98 (1041)	24.05 (611)	24.55 (624)	5.50 (140)	2.00 (51)		2"	40.29 (1023)	6.05 (154)	9.20 (234)	16 (406)	M10 Bolt (4PL)	38.18 (970)	8.75 (222)	445 (201.85)
BOLR-1600	38.26 (972)	40.98 (1041)	25.43 (646)	32.80 (833)	9.50 (241)	2.00 (51)		2"	40.29 (1023)	6.05 (154)	9.20 (234)	16 (406)	M10 Bolt (4PL)	38.18 (970)	8.75 (222)	530 (240.40)
BOLR-2000	See diagram above							2"	See diagram above							597 (270.79)

Thermal/Pressure Relief Bypass is different height than pressure only bypass. Consult factory for details.
 Note: We reserve the right to make reasonable design changes without notice. All dimensions are in inches (millimeters) unless noted otherwise.

Specifications

Electric Motor Information (60 HZ Nema Frame)

Model	CMM	CFM	Motor HP	Voltage	Phase	Full Load Amps 230V	Frequency	RPM	Frame	Thermal Overload	Sound dB(A) at 3 FT
BOL-4*	12.5	440	0.12	230	1	0.37	60 HZ	2710	N/A	Yes	61
BOL-8	22.65	800	1/3	115/230	1	3.0	60 HZ	3450	48C	No	80
	22.65	800	1/3	208-230/460	3	1.4	60 HZ	3450	48C	No	80
BOL-16	40.35	1425	1/2	115/230	1	3.7	60 HZ	3450	48C	No	85
	40.35	1425	1/2	208-230/460	3	2.2	60 HZ	3450	48C	No	85
BOL-30	62.29	2200	1/2	115/230	1	3.7	60 HZ	1725	56C	No	85
	62.29	2200	1/2	208-230/460	3	2.0	60 HZ	1725	56C	No	85
BOL-400	62.29	2200	1	115/230	1	6.0	60 HZ	3450	56C	No	97
	62.29	2200	1	208-230/460	3	3.2	60 HZ	3450	56C	No	97
BOL-725	101.94	3600	1-1/2	115/230	1	8.5	60 HZ	3450	56C	No	100
	101.94	3600	1-1/2	208-230/460	3	4.8	60 HZ	3450	56C	No	100
BOL-950	133.10	4700	1-1/2	115/230	1	8.6	60 HZ	1725	145TC	No	92
	133.10	4700	1-1/2	208-230/460	3	4.6	60 HZ	1725	145TC	No	92
BOL-1200	198.22	7000	5	230	1	23	60 HZ	1740	184TC	No	92
	198.22	7000	3	208-230/460	3	8.8	60 HZ	1725	182TC	No	94
BOL-1600	223.75	7900	5	208-230/460	3	13.4	60 HZ	1725	184TC	No	96
BOL-2000	396.44	14000	7.5	230/460	3	24.8	60 HZ	1725	213TC	No	98

*BOL-4 is a custom 50/60 HZ motor. It is not NEMA or IEC. Additional 2 µF capacitor required (between black and brown wires). Not supplied with motor.

Electric Motor Information (50 HZ IEC Frame)

Model	CMM	CFM	KW	Voltage	Phase	Frequency	RPM	Frame	Sound dB(A) at 3 FT
BOL-4*	11.5	405	0.07	230	1	50 HZ	2485	N/A	58
BOL-8	18.9	667	.25	230/400/415	3	50 HZ	3000	63	71
BOL-16	33.7	1188	.37	230/400/415	3	50 HZ	3000	71	77
BOL-30	52.4	1850	.37	230/400/415	3	50 HZ	1500	71	73
BOL-400	52.4	1850	.75	230/400/415	3	50 HZ	3000	80	81
BOL-725	85.0	3000	1.10	230/400/415	3	50 HZ	3000	80	80
BOL-950	108.2	3821	1.50	230/400/415	3	50 HZ	1500	90	78
BOL-1200	165.1	5834	2.20	230/400/415	3	50 HZ	1500	100	83
BOL-1600	186.4	6584	3.00	230/400/415	3	50 HZ	1500	100	85
BOL-2000	331.3	11700	4.00	230/400/415	3	50 HZ	1500	112	88

*BOL-4 is a custom 50/60 HZ motor. It is not NEMA or IEC. All IEC frame motors have CE mark. IEC motor voltages have +/- 5% tolerance.

Hydraulic Motor Information

Model	Oil Flow Required GPM (LPM)	Min. Pressure Required PSI (BAR)	Motor IN ³ /REV (CM ³ /REV) Displacement	Sound dB(A) at 3 FT
BOL-8	3.3 (12.49)	175 (12.1)	0.22 (3.6)	80
BOL-16	3.3 (12.49)	275 (17.9)	0.22 (3.6)	85
BOL-30	3.4 (12.87)	275 (17.9)	0.45 (7.3)	85
BOL-400	3.3 (12.49)	520 (35.9)	0.22 (3.6)	97
BOL-725	3.3 (12.49)	675 (46.50)	0.22 (3.6)	100
BOL-950	10.1 (38.23)	300 (20.70)	1.4 (22.9)	92
BOL-1200	10.1 (38.23)	725 (50.00)	1.4 (22.9)	94
BOL-1600	10.1 (38.23)	1100 (75.80)	1.4 (22.9)	96
BOL-2000	10.1 (38.23)	1650 (113.76)	1.4 (22.9)	98

Notes: Maximum Pressure is 2000 PSI. Stated Minimum Operating Pressure is at Inlet Port of Motor. 1000 PSI Allowable Back Pressure.

Selection Procedure

STEP 1 Determine Heat Load. Typical application, size cooler for 1/3 of the input horsepower. Heat load may be expressed as either Horsepower or BTU/HR or KW/°C.

$$\text{HP} = \text{BTU/HR} \div 2545 \qquad \text{KW} = \text{HP} \times .745$$

$$\text{BTU/HR} = \text{HP} \times 2545$$

STEP 2 Determine Entering Temperature Difference.
(Actual ETD)

$$\text{ETD} = \text{Entering oil temperature} - \text{Entering Ambient air temperature}$$

The entering oil temperature is generally the maximum desired system oil temperature.

Entering air temperature is the highest Ambient Air temperature the application will see.

STEP 3 Determine the Corrected Heat Dissipation to use the Curves

ENGLISH Version

$$\text{Corrected Heat Rejection} = \frac{\text{Heat Load (BTU/HR)}}{\text{Desired ETD}} \times \frac{100^\circ\text{F}}{100^\circ\text{F}}$$

(BTU/HR) to use with selection chart

STEP 4 Select Model From Curves Enter the Performance Curves at the bottom with the GPM oil flow and proceed upward to the adjusted Heat Rejection from Step 3. Any Model or Curve on or above this point will meet these conditions.

STEP 5 Calculate Oil Pressure Drop Find the oil pressure drop correction factor and multiply it by the Oil Pressure Drop found on performance curve.

Listed Performance Curves are based on:

- 50 SSU (11 cSt) oil
- 100°F (55.56°C) Entering Temperature Difference (ETD)

If your application conditions are different, then continue with the selection procedure.

Oil Temperature

Typical operating temperature ranges are:

Hydraulic Motor Oil	120°F - 180°F (49°C - 82.2°C)
Hydrostatic Drive Oil	160°F - 180°F (71°C - 82.2°C)
Engine Lube Oil	180°F - 200°F (82.2°C - 93.3°C)
Automatic Transmission Fluid	200°F - 300°F (93.3°C - 149°C)

Desired Reservoir Temperature

Oil Temperature: Oil coolers can be selected using entering or leaving oil temperatures.

Off-Line Recirculation Cooling Loop: Desired reservoir temperature is the oil temperature entering the cooler.

Return Line Cooling: Desired reservoir temperature is the oil temperature leaving the cooler. In this case, the oil temperature change must be determined so that the actual oil entering temperature can be found. Calculate the oil temperature change (oil ΔT) with this formula:

$$\text{Oil } \Delta T = (\text{BTU's/HR}) / (\text{GPM Oil Flow} \times 210).$$

To calculate the oil entering temperature to the cooler, use this formula:

$$\text{Oil Entering Temp.} = \text{Oil Leaving Temp.} + \text{Oil } \Delta T.$$

Oil Pressure Drop: Most systems can tolerate a pressure drop through the heat exchanger of 20 to 30 PSI. Excessive pressure drop should be avoided. Care should be taken to limit pressure drop to 5 PSI or less for case drain applications where high back pressure may damage the pump shaft seals.

Pressure Drop

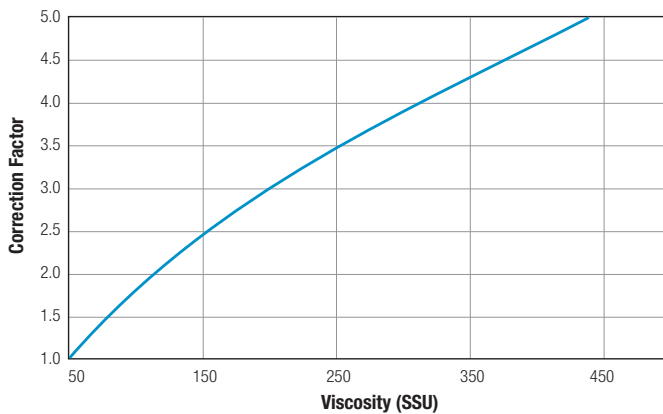

Performance Curves

BOL Models with Standard P-BAR Core

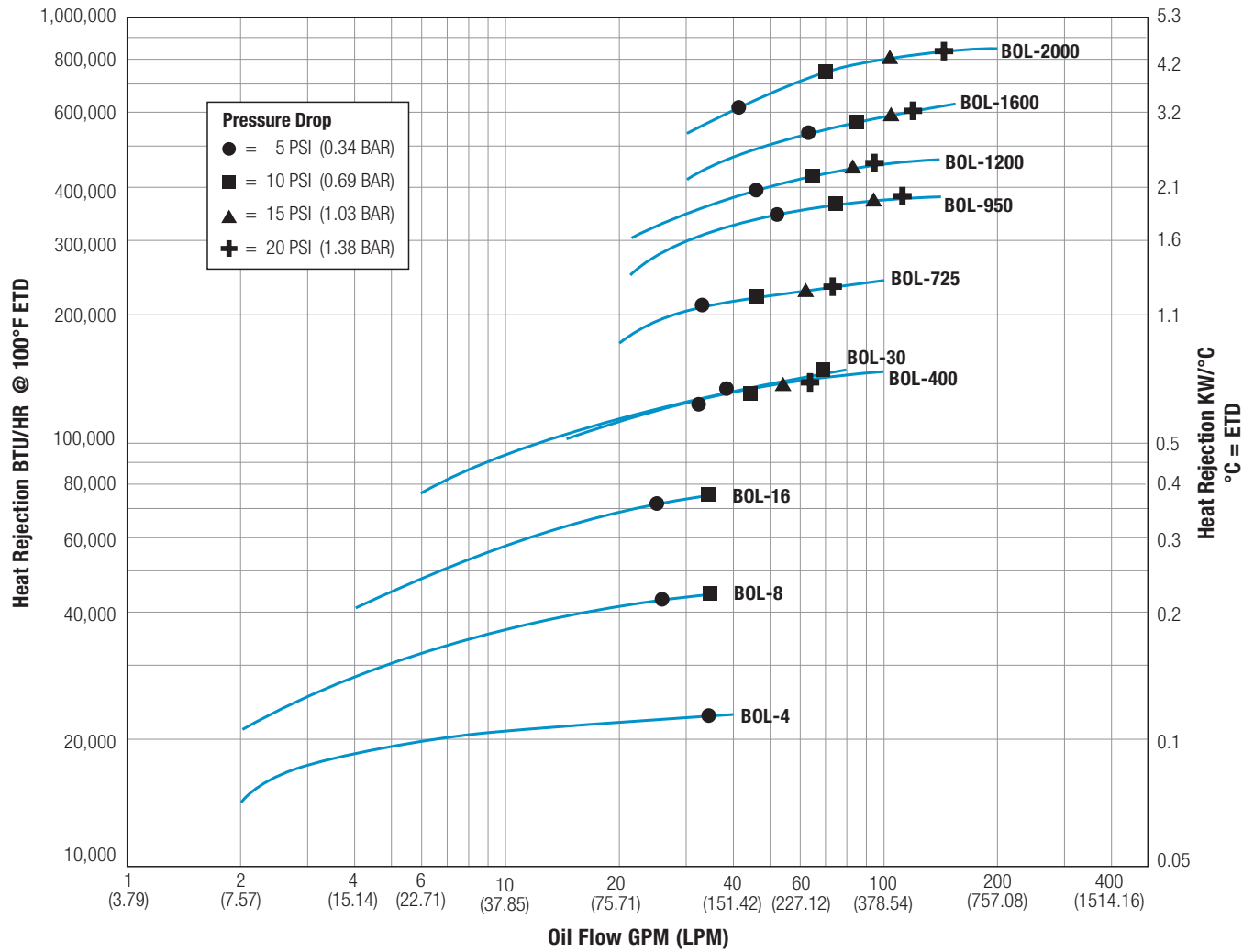

Note: Derate heat rejection values 15% if using 50 HZ motors.

Performance Curves

BOL Models with Optional T-BAR Core

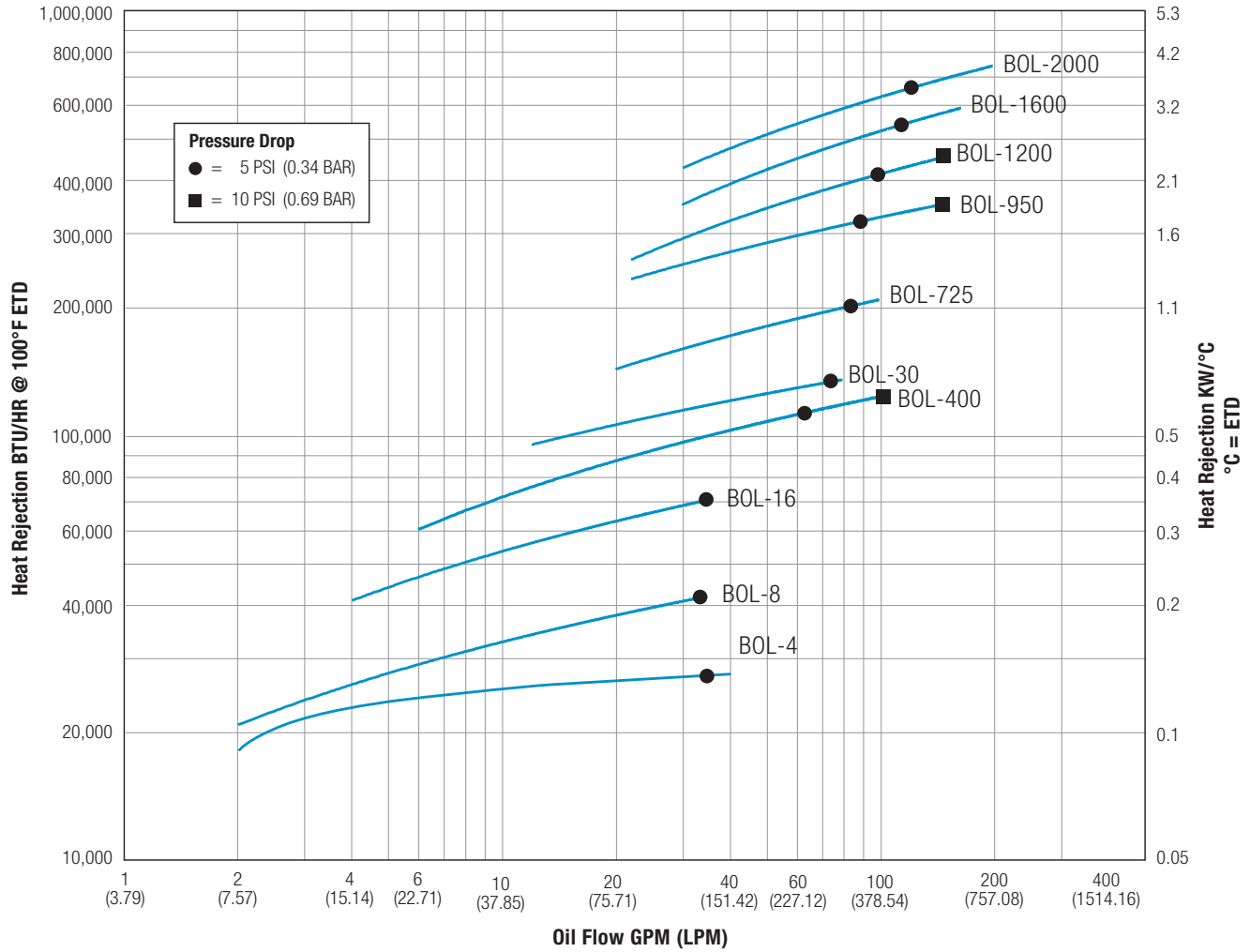

Note: Derate heat rejection values 15% if using 50 HZ motors.

Performance Curves

BOL Models with Low-Noise Option

The low noise option offers the BOL models with a reduced motor speed. This allows a lower sound level output for noise-sensitive applications.

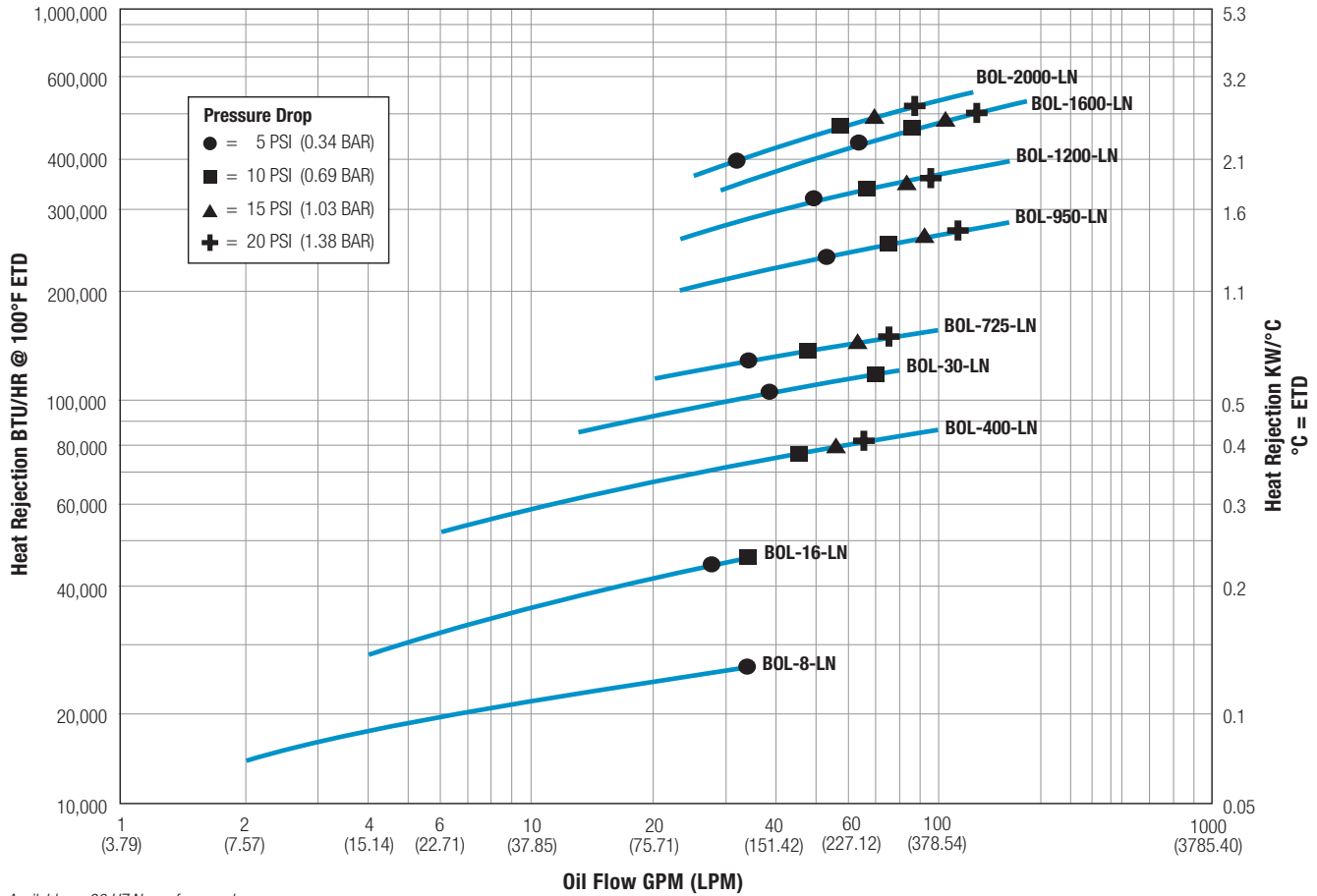

Available on 60 HZ Nema frame only.

Electric Motor Information

Model	HP	Frame	Low Noise RPM	Low Noise CFM	Low Noise CMM	Voltage	Frequency (HZ)
8-1PH	0.33	48	1725	400	11.33	115/230	60
8-3PH	0.33	48	1725	400	11.33	208-230/460	60
16-1PH	0.50	48	1725	704	19.93	115/230	60
16-3PH	0.50	48	1725	704	19.93	208-230/460	60
30-1PH	0.50	56C	1160	1470	41.62	115/230	60
30-3PH	0.50	56C	1160	1470	41.62	208-230/460	60
400-1PH	1.00	56C	1725	1100	31.19	115/230	60
400-3PH	1.00	56C	1725	1100	31.19	208-230/460	60
725-1PH	1.50	56C	1725	1780	50.40	115/230	60
725-3PH	1.50	56C	1725	1780	50.40	208-230/460	60
950-1PH	1.50	145TC	1160	3150	89.19	115/230	60
950-3PH	1.50	145TC	1160	3150	89.19	208-230/460	60
1200-3PH	1.50	182TC	1160	4690	132.81	208-230/460	60
1600-3PH	2.00	184TC	1160	6510	184.34	208-230/460	60
2000-3PH	5.00	213TC	1160	8700	000.00	230/460	60

Sound Data

Model	DBA at 3 FT
BOL-8-LN	62
BOL-16-LN	69
BOL-30-LN	67
BOL-400-LN	72
BOL-725-LN	82
BOL-950-LN	76
BOL-1200-LN	75
BOL-1600-LN	78
BOL-2000-LN	85

Low noise ratings are lab tested in a 1/4 spherical pattern. Additional nearby objects can increase the sound level.