

# Temposonics®

Magnetostrictive, Absolute, Non-contact  
Linear-Position Sensors



**R-Series Model RD4**  
Direct Position and Velocity Output

Document Part Number  
551166 Revision A

## Data Sheet



### FEATURES

- R-Series Detached Electronics Sensor
- Linear, Absolute Measurement
- Non-Contact Sensing Technology
- Linearity Deviation Less Than 0.02%
- Repeatability Within 0.001%
- Full Range of Outputs: Voltage, Current, SSI, CANbus, DeviceNet, Profibus, EtherCAT® and EtherNet/IP
- Simultaneous Multi-Position and Velocity Measurements
- LEDs For Sensor Status and Diagnostics

### BENEFITS

- Detached Sensor Electronics Provide for the Smallest R-Series sensor Head
- Allows Isolating the Sensor Electronics From High Temperatures, High Vibration / Shock, or Other Environmental Extremes

### APPLICATIONS

- Clevis Mount Cylinders Having Minimal Space Available
- High Temperatures or High Vibration / Shock Levels that Require Remote Mounting of the Sensor Electronics
- Space Limited Applications

### TYPICAL INDUSTRIES

- Fluid Power
- Steel Mills
- Material Handling and Packaging
- Woodworking, Metalworking and Assembly Tools

### Time-based Magnetostrictive position sensing principle

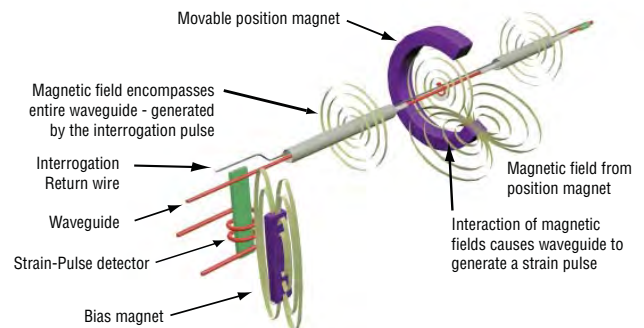

### Benefits of Magnetostriction

Temposonics linear-position sensors use the time-based magnetostrictive position sensing principle developed by MTS. Within the sensing element, a sonic-strain pulse is induced in a specially designed magnetostrictive waveguide by the momentary interaction of two magnetic fields. One field comes from a moveable permanent magnet that passes along the outside of the sensor. The other field comes from an “interrogation” current pulse applied along the waveguide. The resulting strain pulse travels at sonic speed along the waveguide and is detected at the head of the sensing element.

The position of the magnet is determined with high precision and speed by accurately measuring the elapsed time between the application of the interrogation pulse and the arrival of the resulting strain pulse with a high-speed counter. The elapsed time measurement is directly proportional to the position of the permanent magnet and is an absolute value. Therefore, the sensor's output signal corresponds to absolute position, instead of incremental, and never requires recalibration or re-homing after a power loss. Absolute, non-contact sensing eliminates wear, and guarantees the best durability and output repeatability.

All specifications are subject to change. Contact MTS for specifications and engineering drawings that are critical to your application. Drawings contained in this document are for reference only. Go to <http://www.mtssensors.com> for the latest support documentation and related media.

## R-Series Model RD4 Product Overview, Output and Specifications

### Product overview

The Temposonics RD4 position sensor provides an added degree of flexibility compared to the standard R-Series rod style sensor package. The RD4 design utilizes a separate electronics housing and interconnection cable to allow installation of the sensor rod into small spaces. By relocating the electronics, the head of the sensor rod is reduced to its minimal size. This makes the RD4 ideal for use with clevis mount cylinders or any space limited cylinder application. Also, the RD4 sensor can be used for applications that require remote mounting of the sensor electronics due to environmental factors, such as, high temperatures or high levels of shock and vibration.

The RD4 interconnection cable exits the head of the sensor rod and connects to the electronics housing. The electronics housing, along with its mounting block, can be configured with either a side cable connection or a bottom cable connection. The side cable connection is for use with threaded rod styles; 'M', 'T', 'C' and 'D'. These threaded rod styles provide for easy sensor installation into a standard threaded port opening on the top of the cylinder end cap.

The bottom cable connection is for use with the pressure-fit rod style (i.e. style 'S'). The rod style 'S' requires an appropriately machined cavity in the cylinder end cap to house the head of the sensor rod. Also, a hole going through the end cap is needed to channel the interconnection cable to the electronics housing that mounts on the side of the end cap. Proper design and careful sensor installation is required to assure the correct fit and o-ring sealing. MTS factory assistance is recommended when designing for the rod style 'S' in all new RD4 applications.

### Output options

The R-Series Model RD4 sensor is available in voltage, current, SSI, CANbus, DeviceNet, Profibus, EtherCAT® and EtherNet/IP outputs.

#### Important specification note:

For R-Series model specific specifications, consult the individual data sheets applicable to the sensor output(s) for your application.

### Product specifications

Parameters	Specifications	Parameters	Specifications
<b>OUTPUT</b>		<b>EMC test‡:</b>	
<b>Measured output variables:</b>	Position, velocity, simultaneous multi-position and velocity measurements. (Measured output variables depend on the complete sensor model used.)	<b>Electromagnetic emission:</b>	IEC/EN 50081-1
<b>Resolution:</b>	Output dependent	<b>Electromagnetic susceptibility:</b>	IEC/EN 50082-2
<b>Update times:</b>	Output dependent		IEC/EN 61000-4-2/3/4/6, level 3/4 criterion A, CE qualified
<b>Linearity deviation:</b>	< ± 0.02% full stroke (minimum ± 50 µm)‡		‡ Sensor rod and interconnection cable is mounted inside a hydraulic housing or metal housing.
	‡ For rod style 'S' the linearity deviation can be higher in the first 30 mm (1.2 in.) of stroke length.	<b>Shock rating:</b>	100 g (single hit)/ IEC standard 68-2-27 (survivability)
<b>Repeatability:</b>	< ± 0.001% full stroke (minimum ± 2.5 µm)	<b>Vibration rating:</b>	10 g/10 to 2000 Hz, IEC standard 68-2-6 (operational)
<b>Hysteresis:</b>	< 4 µm, 2 µm typical	<b>WIRING</b>	
<b>Outputs:</b>	Voltage, current, SSI, CANbus, DeviceNet, Profibus, EtherCAT and EtherNet/IP	<b>Connection type:</b>	Connector or integral cable (output dependent)
<b>Measuring range:</b>	25 to 5080 mm (1 to 200 in.)	<b>ROD STYLE SENSOR (MODEL RD4)</b>	
<b>ELECTRONICS</b>		<b>Electronic head:</b>	Aluminum housing with diagnostic LED display. (LEDs located beside connector/cable exit)
<b>Operating voltage:</b>	+24 Vdc nominal: -15% or +20% <b>Polarity protection:</b> up to -30 Vdc <b>Over voltage protection:</b> up to 36 Vdc <b>Current drain:</b> Output dependent <b>Dielectric withstand voltage:</b> 500 Vdc (DC ground to machine ground)	<b>Sealing:</b>	<b>Sensor electronics:</b> IP 67 (with professionally mounted housing and connectors) <b>Sensor rod head with interconnection cable:</b> Threaded style (IP 65) and pressure fit style (IP 30)
<b>ENVIRONMENTAL</b>		<b>Sensor rod:</b>	304L stainless steel
<b>Operating conditions:</b>	<b>Operating temperature:</b> -40 °C (-40 °F) to +75 °C (+167 °F) <b>Relative humidity:</b> 90% no condensation	<b>Operating pressure:</b>	350 bar static, 690 bar peak (5000 psi, 10,000 psi peak)
		<b>Mounting:</b>	Any orientation. Threaded flange M18 x 1.5 or 3/4 - 16 UNF-3A or non-threaded pressure fit
		<b>Typical mounting torque:</b>	45 N-m (33 ft. -Lbs.)
		<b>Magnet types:</b>	Ring magnet, open-ring magnet or magnet float

Model RD4 sensor dimension references

R-SERIES RD4 SENSOR WITH SIDE CABLE ELECTRONICS CONNECTION AND ROD STYLE 'M' OR 'T'

Drawing is for reference only, contact applications engineering for tolerance specific information.

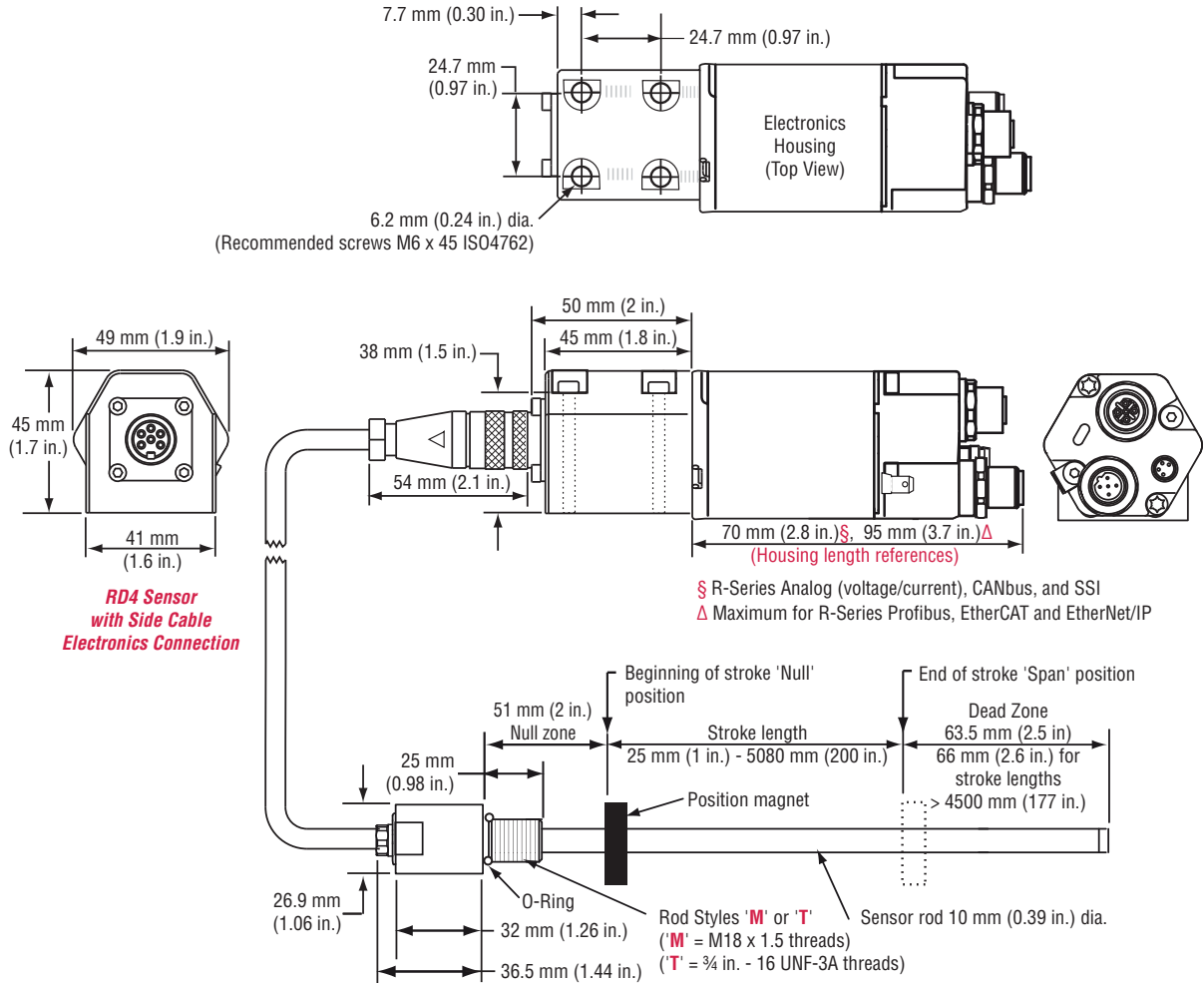

Figure 1. R-Series Model RD4 sensor with side cable electronics connection and rod style 'M' or 'T'

R-SERIES RD4 SENSOR WITH SIDE CABLE ELECTRONICS CONNECTION AND ROD STYLE 'C' OR 'D'

Drawing is for reference only, contact applications engineering for tolerance specific information.

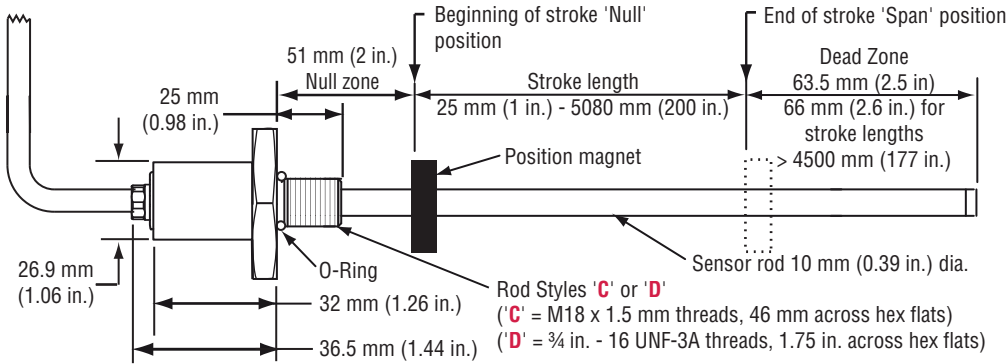

Figure 2. R-Series Model RD4 sensor with side cable electronics connection and rod style 'C' or 'D'

## R-Series Model RD4 Sensor

### Dimension References

#### R-SERIES RD4 SENSOR WITH BOTTOM CABLE ELECTRONICS CONNECTION AND ROD STYLE 'S'

Drawing is for reference only, contact applications engineering for tolerance specific information.

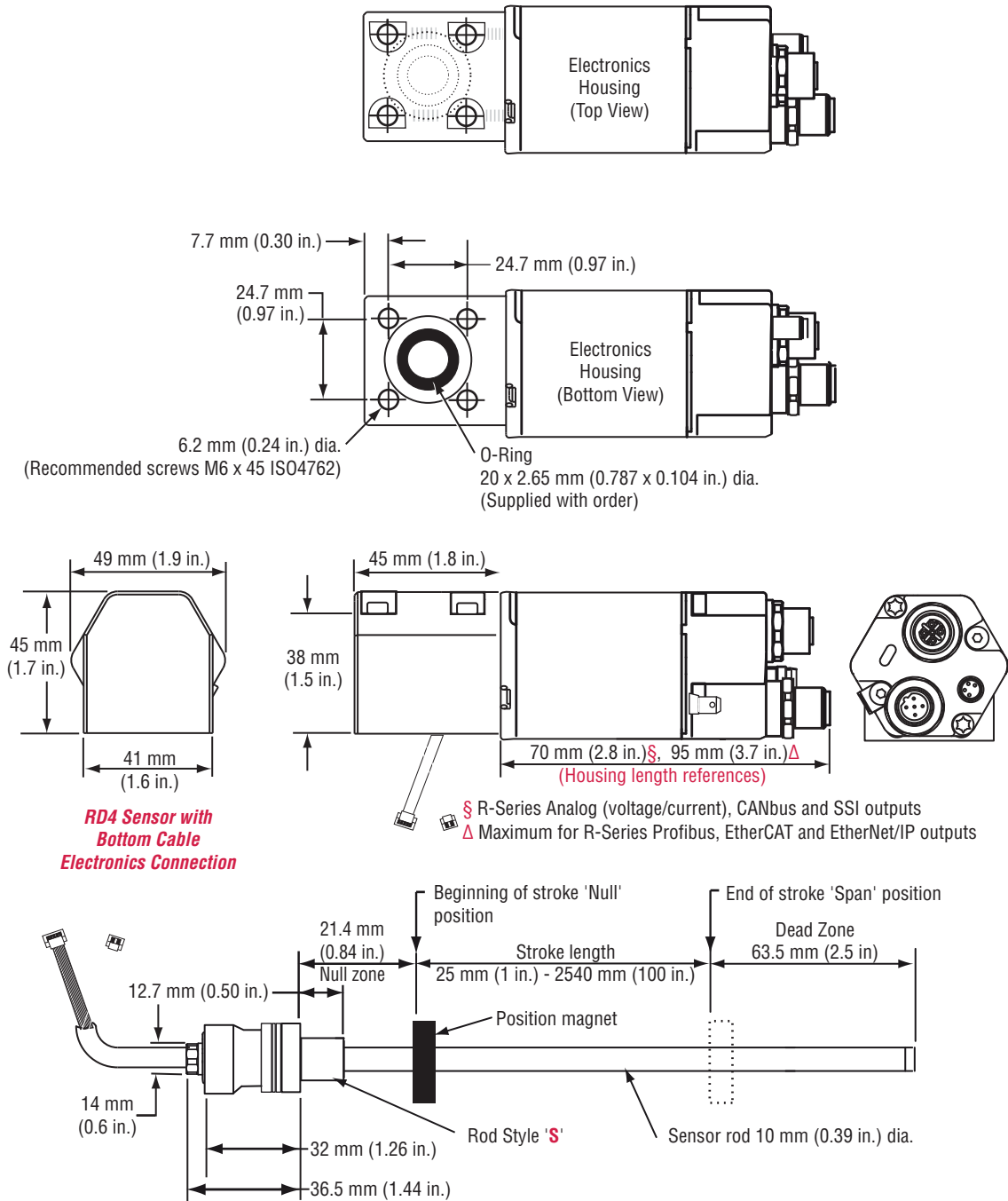

**Figure 3.** R-Series Model RD4 sensor with bottom cable electronics connection and rod style 'S'







## Standard magnet selections (Model RD4)

### POSITION MAGNET SELECTIONS (MAGNET MUST BE ORDERED SEPARATELY)

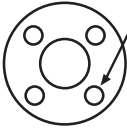
Drawings are for reference only, contact applications engineering for tolerance specific information.

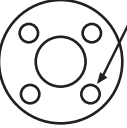
Magnets must be ordered separately with Model RD4 position sensors. The standard ring magnet (part number 201542-2) is suitable for most applications.

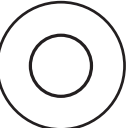
### POSITION MAGNET SELECTIONS (Magnet must be ordered separately) (Drawing dimensions are for reference only)

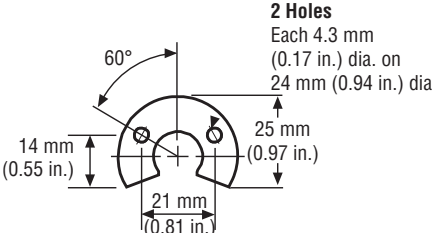
Magnet and magnet dimensions	Description	Part number
  <p>4 Holes Each 4.3 mm (0.17 in.) dia. 90° apart on 24 mm (0.94 in.) dia.</p>	<p><b>Standard ring magnet</b></p> <p>I.D.: 13.5 mm (0.53 in.) O.D.: 33 mm (1.3 in.) Thickness: 8 mm (0.3 in.) Operating temperature: - 40 °C to 100 °C</p>	201542-2
  <p>4 Holes Each 4.3 mm (0.17 in.) dia. 90° apart on 24 mm (0.94 in.) dia.</p>	<p><b>Magnet spacer</b></p> <p>(Non-ferrous, use with ring magnet Part number: 201542-2) I.D.: 14 mm (0.56 in.) O.D.: 32 mm (1.25 in.) Thickness: 3.2 mm (0.125 in.)</p>	400633
 	<p><b>Ring magnet</b></p> <p>I.D.: 13.5 mm (0.53 in.) O.D.: 25.4 mm (1 in.) Thickness: 8 mm (0.3 in.) Operating temperature: - 40 °C to 100 °C</p>	400533
  <p>2 Holes Each 4.3 mm (0.17 in.) dia. on 24 mm (0.94 in.) dia. 60° 14 mm (0.55 in.) 25 mm (0.97 in.) 21 mm (0.81 in.)</p>	<p><b>Open-ring magnet, Style M</b></p> <p>I.D.: 13.5 mm (0.53 in.) O.D.: 33 mm (1.3 in.) Thickness: 8 mm (0.3 in.) Operating temperature: - 40 °C to 100 °C</p> <p>This magnet may influence the sensor performance specifications for some applications.</p>	251416-2

### MAGNET FLOAT SELECTION (Drawing dimensions are for reference only)

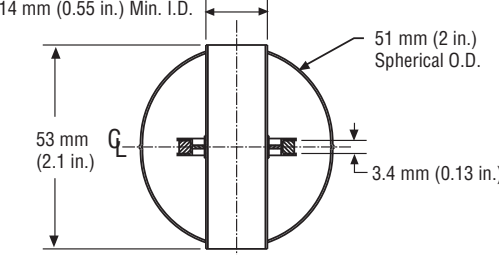
  <p>14 mm (0.55 in.) Min. I.D. 53 mm (2.1 in.) 51 mm (2 in.) Spherical O.D. 3.4 mm (0.13 in.)</p>	<p><b>Magnet float</b></p> <p>(Level sensing applications) Specific gravity: 0.70 maximum Pressure: 870 psi maximum</p> <p>(This float is used with Model RH rod-style sensors for hydraulic fluid or fresh water applications only). Collar (part no.: 560777) is recommended for end of stroke stops.</p>	251447
--	---	--------

**R-Series Model RD4 Sensors  
Installation and Mounting References**

**Sensor cylinder installation for side cable connection and threaded rod styles**

**Cylinder Installation Note:**

The position magnet requires minimum distances away from ferrous metals to allow proper sensor output. The minimum distance from the front of the magnet to the cylinder end cap is 15 mm (0.6 in.). The minimum distance from the back of the magnet to the piston head is 3.2 mm (0.125 in.). The non-ferrous spacer (part no.: 400633), provides this minimum distance when used along with the standard ring magnet (part no.: 201542-2).

**R-SERIES RD4 SENSOR CYLINDER INSTALLATION WITH SIDE CABLE CONNECTION AND ROD STYLES 'M' AND 'T'**

*Drawing is for reference only, contact applications engineering for tolerance specific information.*

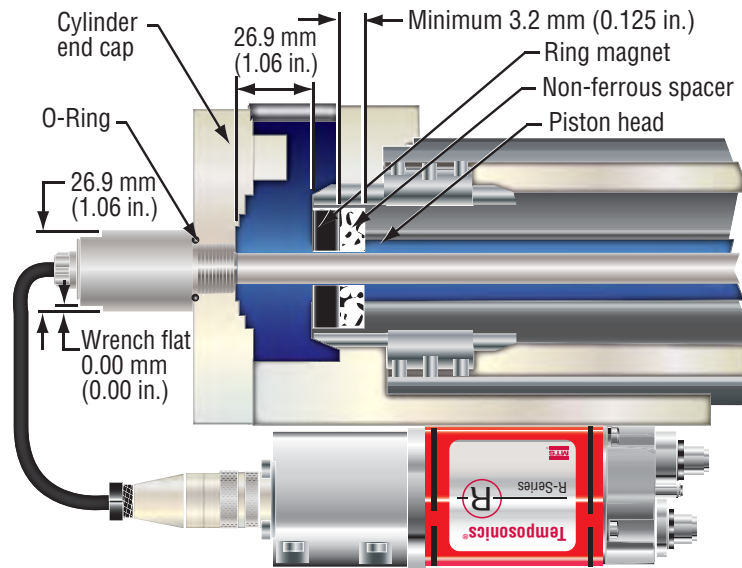

**Figure 4.** R-Series Model RD4 sensor installation using side cable connection and rod styles 'M' or 'T'

**R-SERIES RD4 SENSOR CYLINDER INSTALLATION FOR SIDE CABLE CONNECTION AND ROD STYLES 'C' AND 'D'**

*Drawing is for reference only, contact applications engineering for tolerance specific information.*

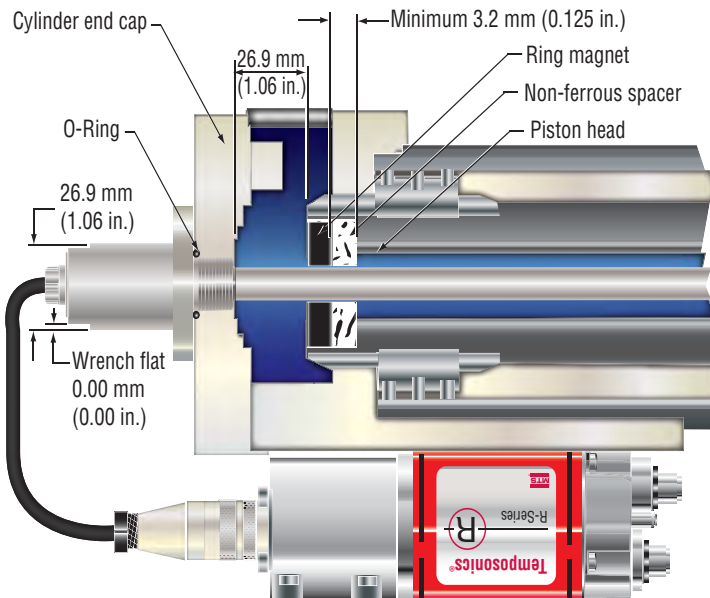

**Figure 5.** R-Series Model RD4 sensor installation using side cable connection and rod styles 'C' and 'D'



## Sensor cylinder installation for bottom cable connection and pressure fit rod style

### R-SERIES RD4 SENSOR CYLINDER INSTALLATION FOR BOTTOM CABLE CONNECTION AND PRESSURE FIT ROD STYLE 'S'

*Drawing is for reference only, contact applications engineering for tolerance specific information.*

#### Pressure fit rod style 'S' installation Notes:

1. The position magnet requires minimum distances away from ferrous metals to allow proper sensor output. When using rod style 'S' mounted inside a cylinder end cap, the minimum distance from the front of the magnet to the cylinder end cap is 21 mm (0.83 in.).
2. The minimum distance from the back of the magnet to the piston head is 3.2 mm (0.125 in.). The non-ferrous spacer (part no.: 400633), provides this minimum distance when used along with the standard ring magnet (part no.: 201542-2).
3. In the event that the position magnet is to be secured in the piston head by using a ferrous circlip, then an additional non-ferrous spacer is recommended on the front side of the magnet (as shown below ‡).

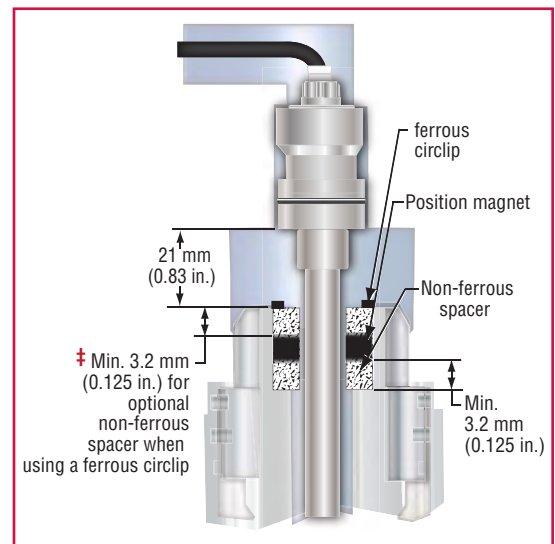
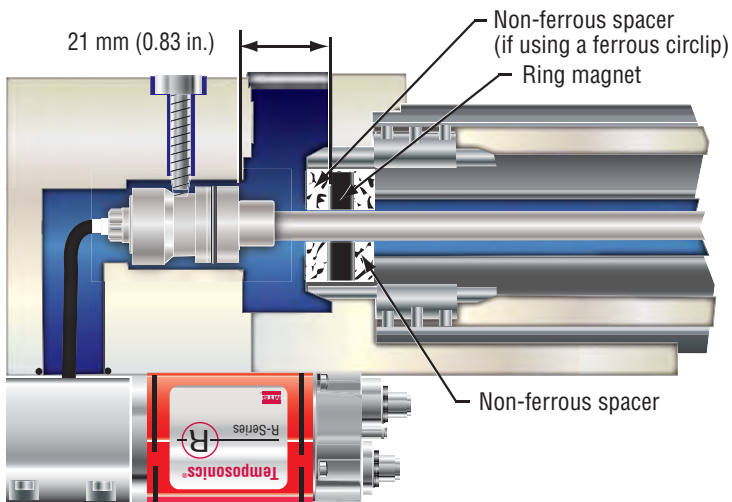

**Figure 6.** R-Series Model RD4 sensor installation using bottom cable connection and pressure fit rod style 'S'

## Cylinder end cap mounting and pressure-fit rod style 'S' detail references

*Drawings are for reference only, contact applications engineering for tolerance specific information.*

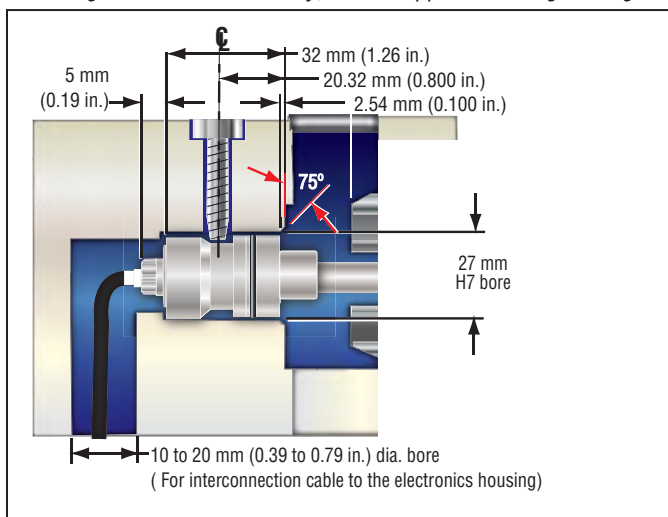

**Figure 7.** Cylinder end cap mounting detail reference

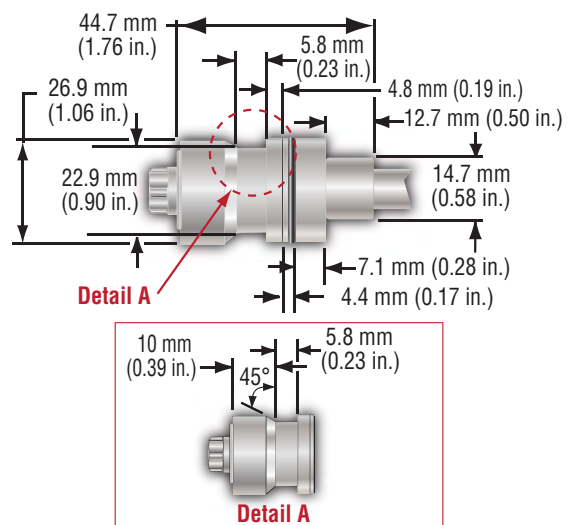
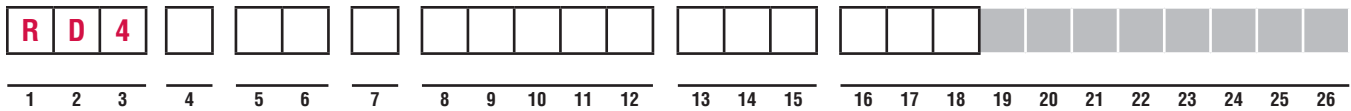

**Figure 8.** Pressure fit rod style 'S' details

# R-Series Model RD4 Sensors

## Ordering Information

(16 up to 26 depending on R-Series output)



To complete the sensor output model number, consult the specific ordering information page for the R-Series output you need.

**SENSOR MODEL** \_\_\_\_\_ = R D 4 **1-3**

**RD4** = Model RD4 compact sensor with detached electronics (Magnet must be ordered separately)

**SENSOR ROD STYLE** \_\_\_\_\_ =   **4**

**M** = Metric threaded rod style, M18 x 1.5      **C** = Metric threaded hex flange style, M18 x 1.5  
**T** = US customary threaded rod style 3/4 -16 in.    **D** = US customary threaded hex flange style, 3/4 -16 in.  
**S** = Pressure fit style head

**SENSOR ROD INTERCONNECTION CABLE** \_\_\_\_\_ =     **5-6**

For side connection into the electronics housing (requires housing option 'S' for designator no. 7)

**D1** = 250 mm (9.8 in.), PUR jacket cable, hanging connector M16 male  
**D2** = 400 mm (15.7 in.), PUR jacket cable, hanging connector M16 male  
**D3** = 600 mm (23.6 in.), PUR jacket cable, hanging connector M16 male

For bottom connection into the electronics housing (requires housing option 'B' for designator no. 7)

**R4** = 170 mm (6.7 in.), PUR jacket cable with wires terminated into 2 flat connectors  
**R5** = 230 mm (9.1 in.), PUR jacket cable with wires terminated into 2 flat connectors  
**R6** = 350 mm (13.8 in.), PUR jacket cable with wires terminated into 2 flat connectors

**SENSOR ELECTRONICS HOUSING STYLE** \_\_\_\_\_ =   **7**

**S** = Side cable electronics connection  
**B** = Bottom cable electronics connection

**STROKE LENGTH** \_\_\_\_\_ =           **8-12**

----- **M** = Millimeters (Encode in 5 mm increments)  
----- **U** = Inches and tenths (Encode in 0.1 in. increments)

**OUTPUT CONNECTION TYPE** (Connector and integral cable options are dependent on output type selected) \_\_\_\_\_ =       **13-15**

**OUTPUT (16 UP TO 26)** \_\_\_\_\_ =                                       **16-26**

Number designations (16 to 26) are dependent on the output type selected. To complete this ordering option, refer to the applicable product specific R-Series output (Analog, SSI, CANbus, DeviceNet, Profibus, EtherCAT or EtherNet/IP) data sheet for specific number designations

**INPUT VOLTAGE NOTE:** number designation not required for input voltage (Standard 24 Vdc +20%, -15%).



Document Part Number: 551166, Revision A 04/10, 10/11

MTS and Temposonics are registered trademarks of MTS Systems Corporation. All other trademarks are the property of their respective owners. Printed in USA. Copyright © 2011 MTS Systems Corporation. All Rights Reserved in all media.



**MTS Systems Corporation  
Sensors Division**

3001 Sheldon Drive  
Cary, North Carolina  
27513, USA  
Tel.: +1-800-633-7609  
Fax: +1-919-677-2343  
      +1-800-498-4442  
e-mail: sensorsinfo@mts.com  
http://www.mtssensors.com

**MTS Sensor Technologie  
GmbH & Co. KG**

Auf dem Schüffel 9  
D - 58513 Lüdenscheid, Germany  
Tel.: +49-2351-9587-0  
Fax: +49-2351-56491  
e-mail: info@mtssensor.de  
http://www.mtssensor.de

**MTS Sensors Technology  
Corporation**

737 Aihara-cho, Machida-shi  
Tokyo 194-0211, Japan  
Tel.: +81-42-775-3838  
Fax: +81-42-775-5516  
e-mail: info@mtssensor.co.jp  
http://www.mtssensor.co.jp