

Temposonics®

Magnetostrictive, Absolute, Non-contact
Linear-Position Sensors



G-Series Models GP and GH

Analog (Voltage/Current)/Digital-Pulse Outputs

Document Part Number
550959 Revision G

Data Sheet



Model GP Profile-style position sensor

Model GH Rod-style position sensor

FEATURES

- Linear, Absolute Measurement
- Non-Contact Sensing Technology
- LEDs For Enhanced Sensor Diagnostics
- Programmability, Analog Output Models: Voltage or Current, Fully Adjustable Outputs Within: -10 to +10 Vdc or 0 to 20 mA
- Programmability, Digital-Pulse Output Models: PWM or Start/Stop
- Simultaneous Multi-Magnet Measurements Using Start/Stop
- Linearity Deviation Less Than 0.02%
- Repeatability Within 0.001%
- Designed for Backward Compatibility with Legacy Temposonics Products
- Standard 24 Vdc and extended input power supply options for compatibility with older controller interfaces
- Integral connector replacement options including: Hanging (inline) connectors, Adapter cables, Field-installed connector kits

BENEFITS

- Rugged Industrial Sensor, Backward Compatible with Tempo I, Tempo II and L-Series Legacy Products
- Compact electronics housing for applications with limited space
- Offers Supply Options for Compatibility with Older Controller Interfaces

APPLICATIONS

- Continuous Operation In Harsh Industrial Conditions
- High Pressure Conditions

TYPICAL INDUSTRIES

- Fluid Power
- Lumber and Woodworking
- Stamping and Diecasting
- Metalworking, Presses and Assembly Tools
- Material Handling and Packaging

Time-based Magnetostrictive position sensing principle

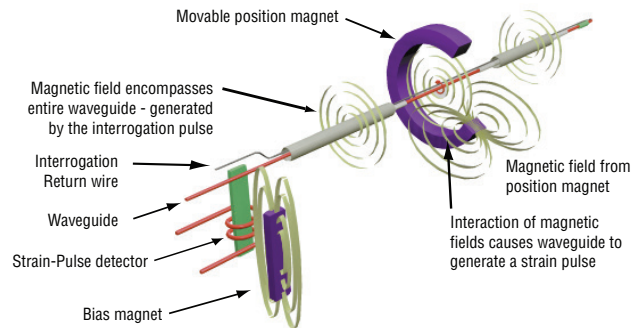

Benefits of Magnetostriction

Temposonics linear-position sensors use the time-based magnetostrictive position sensing principle developed by MTS. Within the sensing element, a sonic-strain pulse is induced in a specially designed magnetostrictive waveguide by the momentary interaction of two magnetic fields. One field comes from a movable permanent magnet that passes along the outside of the sensor. The other field comes from an “interrogation” current pulse applied along the waveguide. The resulting strain pulse travels at sonic speed along the waveguide and is detected at the head of the sensing element.

The position of the magnet is determined with high precision and speed by accurately measuring the elapsed time between the application of the interrogation pulse and the arrival of the resulting strain pulse with a high-speed counter. The elapsed time measurement is directly proportional to the position of the permanent magnet and is an absolute value. Therefore, the sensor's output signal corresponds to absolute position, instead of incremental, and never requires recalibration or re-homing after a power loss. Absolute, non-contact sensing eliminates wear, and guarantees the best durability and output repeatability.

All specifications are subject to change. Contact MTS for specifications and engineering drawings that are critical to your application. Drawings contained in this document are for reference only. Go to <http://www.mtssensors.com> for the latest support documentation and related media.

Product Overview and Specifications

Product overview

G-Series sensors feature a microprocessor-based design with enhanced diagnostics and programmability offering the flexibility to fit a wide range of applications. The sensor's head contains the active signal conditioning and a complete integrated electronics interface. Double shielding is used to ensure EMI protection for unsurpassed reliability and operating safety. G-Series model GH and GP sensors are extremely robust and are ideal for continuous operation under harsh industrial conditions. Backward compatibility with upgraded performance is one of the primary benefits of choosing a G-Series sensor. The G-Series sensor provides the same functionality as our legacy Temposonics I, II and L-Series sensor products which make it an ideal direct replacement.

MTS offers two standard sensor housings, rod and profile extrusion. The rod housing is capable of withstanding high pressures such as those found in hydraulic cylinders. The profile extrusion housing provides convenient mounting options and captive-sliding magnets which utilize slide bearings of special material that reduce friction, and help mitigate dirt build up.

Product specifications

Parameters	Specifications	Parameters	Specifications
OUTPUT		ENVIRONMENTAL	
Measured output variables:	Position	Operating conditions:	Operating temperature: -40 °C (-40 °F) to 80 °C (176 °F) 85 °C (185 °F) max. ‡ ‡ +80 °C max. for UL Recognition. Contact factory for high temperature applications.
Resolution:	Analog: Infinite (restricted by output ripple) Digital Pulse: 0.1, 0.01 and 0.005 mm (controller dependent)	EMC test:	Relative humidity: 90% no condensation Emissions: IEC/EN 61000-6-3 Immunity: IEC/EN 61000-6-2 IEC/EN 61000-4-2/3/4/5/6/8, level 3/4 criterium A, CE qualified
Update times:	Analog: < 1 ms (typical) Digital (Controller dependent, design reference = (null + stroke+ dead zone) inches x 10.0 µsec/in. x (number of circulations)	Shock rating:	100 g (single hit)/ IEC standard 68-2-27 (survivability)
Linearity deviation:	< ± 0.02% full stroke (minimum ± 50 µm)	Vibration rating:	15 g (30 g with HVR option)/10 to 2000 Hz, IEC standard 68-2-6 (operational)
Repeatability:	< ± 0.001% full stroke (minimum ± 2.5 µm)	WIRING	
Hysteresis:	< 4 µm	Connection type:	6-pin male D60 (M16) connector, 10-pin MS style connector, integral cable, or hanging (inline) connectors
Analog Outputs:	Voltage (Fully adjustable): 0 to 10, 10 to 0, -10 to +10, +10 to -10 Vdc (minimum controller load > 5k ohms) Current (Fully Adjustable): 4(0) to 20 mA, 20 to 4(0) mA (Minimum/maximum load, 0/500 ohms)	PROFILE STYLE SENSOR (MODEL GP)	
Digital-Pulse Outputs:	Start/Stop or Pulse Width Modulation (PWM)	Electronic head:	Aluminum housing with diagnostic LED display (LEDs located beside connector/cable exit)
Stroke Lengths:	GP (Profile style): Analog: 50 to 2540 mm (2 to 100 in.) ^Δ Digital: 50 to 5080 mm (2 to 200 in.) GH (Rod style): Analog: 50 to 2540 mm (2 to 100 in.) ^Δ Digital: 50 to 7620 mm (2 to 300 in.)	Sealing:	IP 65**
	^Δ Contact factory for stroke lengths longer than 2540 mm (100 in.) for Analog outputs	Sensor extrusion:	Aluminum (Temposonics profile style)
ELECTRONICS		Mounting:	Any orientation, adjustable mounting feet or T-slot nut (M5 threads) in bottom groove
Operating voltage:	+24 Vdc nominal: 20.4 - 28.8 Vdc standard +9 to +28.8 Vdc optional*	Magnet types:	Captive-sliding magnet or open-ring magnet
Setpoints:	Setpoint adjustment (Null/Span): 100% of electrical stroke length, 50 mm (2 in.) min. distance between setpoints.	ROD STYLE SENSOR (MODEL GH)	
		Electronic head:	Aluminum housing with diagnostic LED display (LEDs located beside connector/cable exit)
		Sealing:	IP 67 or IP 68 for integral cable models**
		Sensor rod:	304L stainless steel
		Operating pressure:	350 bar static, 690 bar peak (5000 psi static, 10,000 psi peak)
		Mounting:	Any orientation. Threaded flange M18 x 1.5 or 3/4 - 16 UNF-3A
		Typical mounting torque:	45 N-m (33 ft. - lbs.)
		Magnet types:	Ring magnet, open-ring magnet, or magnet float

* UL Recognition requires an approved power supply with energy limitation (UL 61010-1), or Class 2 rating according to the National Electrical Code (USA) / Canadian Electrical Code.

** The IP rating is not part of the UL Recognition.

Output options

G-Series profile-style and rod-style sensors are available in analog and digital-pulse outputs. The G-Series sensor can also provide a square wave neuter output to support legacy Temposonics I, II, and L-Series product backward compatibility.

ANALOG OUTPUTS (VOLTAGE/CURRENT)

G-Series analog sensors provide direct signals, including voltage (0 to 10 Vdc or -10 to +10 Vdc, forward or reverse acting) and current (4 to 20 mA, or 0 to 20 mA, forward or reverse acting). (See 'Figure 1'). Both voltage and current outputs allow full adjustments of null and span setpoints, (minimum 2 in. between setpoints). Since the outputs are direct, no signal-conditioning electronics are needed when interfacing with controllers or meters.

DIGITAL-PULSE OUTPUTS (START/STOP AND PWM)

G-Series digital-pulse sensors provide either PWM (Pulse Width Modulation) or Start/Stop output signals (see 'Figure 2'). For Start/Stop, the sensor requires a start signal from a controller or interface module to initiate the measurement cycle. The sensor generates a stop signal at the end of the measurement cycle that is used to stop the controller's counter clock.

The elapsed time between the start and stop signals is directly proportional to the magnet's position along the active stroke length. The controller can calculate the absolute position of the magnet from the time value and the sensor's unique gradient value, (inverse of the speed for the sonic strain pulse traveling in the sensor's waveguide).

For PWM output, the elapsed time of the measurement cycle is represented as a varying pulse width of the output signal. The duration of the pulse is directly proportional to the magnet's position along the active stroke length. When operated in the PWM mode the sensor can be configured for internal interrogations or external interrogations. Using external interrogations, a signal is required from the controller or interface module to initiate every measurement cycle (i.e. same as Start/Stop). When using the mode for internal interrogations, no signal is needed from the controller as the sensor itself initiates the next measurement cycle upon the completion of the current cycle. Sensor resolution can be improved by using multiple back to back measurement cycles that are grouped together to generate a single PWM output signal.

Using multiple measurement cycles in this fashion is referred to as circulations. Setting the sensor to use 2 circulations improves the measurement resolution 2 times. Likewise, using 3 circulations improves the resolution 3 times, and so on. When using multiple circulations the resulting pulse width is longer, indicating the total time elapsed for all of the circulations added together. Once this elapsed time is measured by the counter clock in the controller, the time value is divided by the number of circulations used. The result can then be divided by the sensor's gradient value to determine the magnet's absolute position.

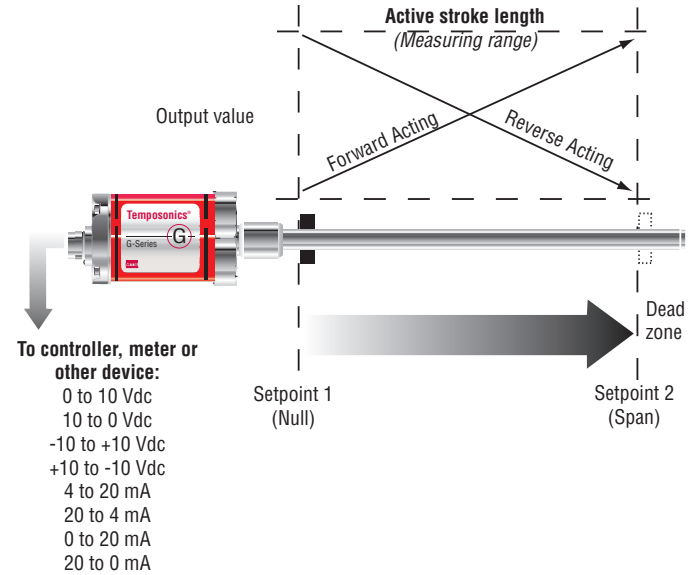

Figure 1. Single magnet analog output diagram

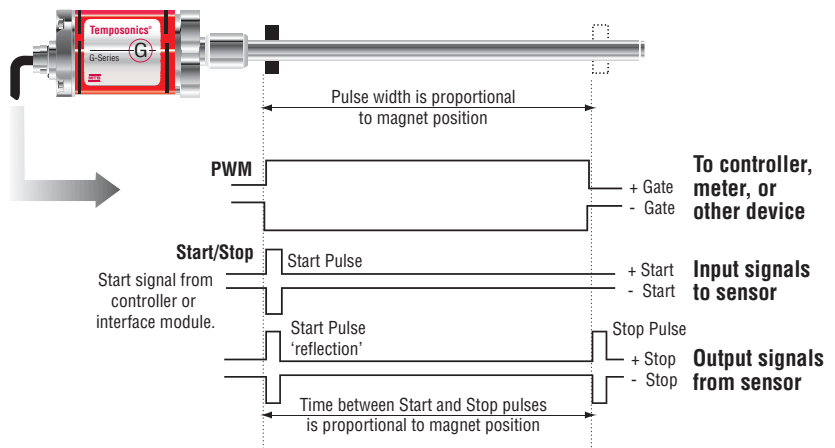

Figure 2. Direct Start/Stop and PWM output diagram

Using multiple circulations will slow down the sensor's update time. However, using multiple circulations has the same effect for improving the measured resolution as it would be to increase the frequency of the counter clock in the controller (Xtal [MHz]), as indicated in the equation below.

$$\text{Resolution (in.)} = \frac{1}{(\text{gradient } \mu\text{s/in.}) \times (\text{Xtal [MHz]}) \times (\# \text{ of circulations})}$$

**G-Series Models GP and GH Sensors
Monitoring, Diagnostics and Advanced Programmability**

Enhanced monitoring and diagnostics

SENSOR STATUS AND DIAGNOSTIC DISPLAY

Diagnostic LEDs (green/red) located beside the connector or cable exit (see 'Figure 3'), provide basic visual monitoring for normal sensor operation and troubleshooting.



Figure 3. G-Series sensor diagnostic LEDs

Green	Red	Operation status/mode
OFF	OFF	No power to sensor
OFF	ON	Self-diagnostic error
ON	OFF	Normal sensor function
ON	ON	Magnet not detected
ON	FLASHING	Missing external Start/interrogation signal
FLASHING	OFF	Serial programming mode
FLASHING	ON	Magnet signal is weak
FLASHING	FLASHING	Supply voltage beyond limits (high or low)

Table 1. Diagnostic LED codes

Advanced communication and programmability

SENSOR FIELD PROGRAMMING AND G-SERIES PC PROGRAMMING KITS

Temposonics G-Series Analog and Digital-pulse output sensors are pre-configured at the factory by model number designation. For many applications, normal sensor installation and operation does not require additional adjustment.

If however, sensor parameter changes are required in the field, MTS has developed the 'G-Series Analog PC Programming Kits', part no. 253311-1 and part no. 253312-1 (see 'Figure 4') which can be purchased separately to easily program the sensor.

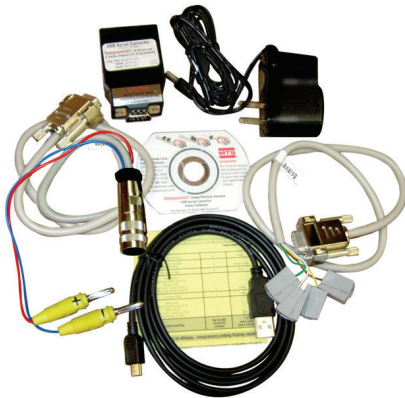

Figure 4. G-Series PC Programming Kit, part no. 253311-1 (Analog) or 253312-1 (Digital-pulse) outputs

G-Series PC setup software is shipped with the sensor and can also be downloaded from www.mtssensors.com. You can use the PC setup software to configure, diagnose, monitor and program your G-Series sensor in the field without opening the sensor's electronics housing.

This can simplify installation and commissioning, saving valuable time. Keeping the sensor electronics isolated ensures that seal integrity and the highest product reliability are maintained.

G-Series PC Programming Kits (part no.: 253311-1 and 253312-1) include the following components:

- Wall adapter style power supply (24 Vdc output)
- USB Serial converter box with USB cable to connect to PC
- Two connection cables:
 - Cable for sensor ordered with the D60 integral connector option.
 - Cable with quick connects for sensor ordered with the integral cable option.
- G-Series PC Setup software, available for download at <http://www.mtssensors.com>.

Software upgrades can be downloaded free of charge from the MTS Sensors website at <http://www.mtssensors.com>.

G-Series PC Setup and Configuration Software Interface

VISUAL SOFTWARE INTERFACE

The G-Series PC Setup and configuration software provides a user-friendly interface (see 'Figure 5') along with the sensor's advanced technology enables the operator to take advantage of the following features:

- Built-in serial interfaces for robust hard-wired serial communication, (RS-422 for digital-pulse output and RS-485 for analog output).
- Remote programmability for operational modes and sensor parameters as shown below.

Analog output	Digital-pulse output
Voltage or current output mode	Start/Stop or PWM output mode
Voltage or current output range	Internal or external interrogation mode when using the PWM mode
Full adjustment for Null and Span setpoints	Number or circulations (1 to 20) when using the PWM mode

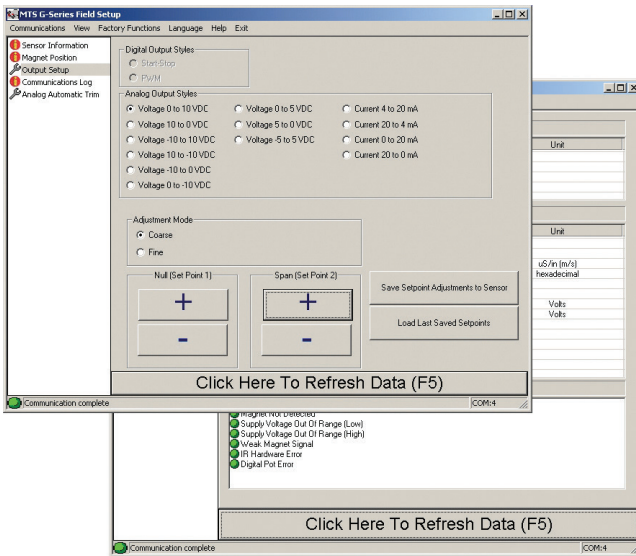

Figure 5. G-Series PC setup software interface examples

G-SERIES ANALOG HANDHELD PROGRAMMER ACCESSORY

Programming for your G-Series analog output sensor can be achieved in the field using the G-Series Analog Handheld Programmer accessory, part no. 253853 (see 'Figure 6').



Figure 6. G-Series Analog Handheld Programmer (part no.: 253853). Front and back views shown.

Using the G-Series Analog Handheld Programmer the magnet positions, and corresponding output values, can be adjusted for the beginning of stroke (Setpoint 1) and for the end of stroke (Setpoint 2) that is actually needed for the specific application. These adjustments are easily done, even when the sensor is not directly accessible, by connecting the programmer to the sensor's integral cable or extension cable. Additionally, the programmer has its own red and green LEDs to provide a remote display of the sensor's LEDs, used for indicating the sensor status and error diagnostics.

For detailed information refer to the G-Series Analog Handheld Programmer Operating Instructions (document part no. 551024) available in PDF format at www.mtssensors.com.

Model GP Profile-Style Sensor
Dimension References

Model GP profile-style sensor dimension references

MODEL GP, PROFILE-STYLE SENSOR WITH STYLE S CAPTIVE-SLIDING MAGNET

Drawing is for reference only, contact applications engineering for tolerance specific information.

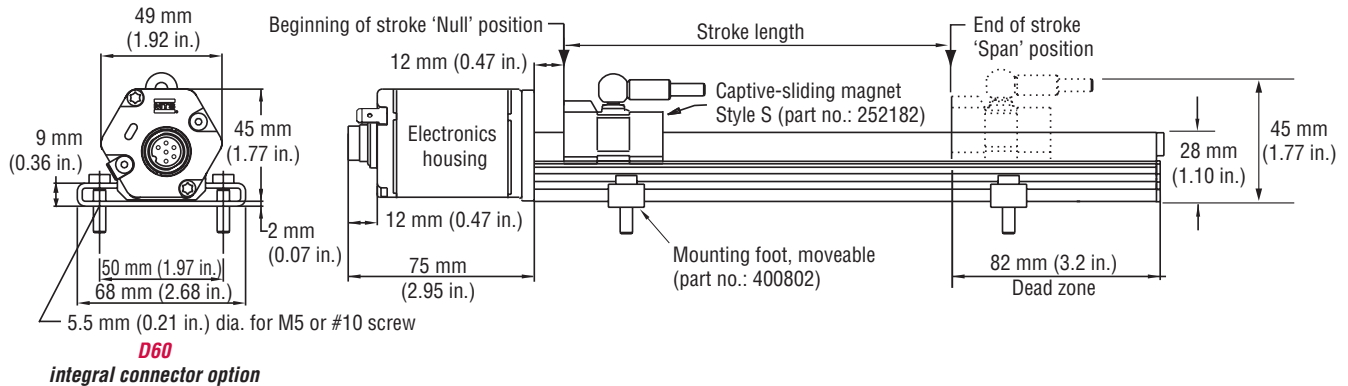

Figure 7. G-Series Model GP Profile-style sensor dimension reference (Shown with the **D60** integral connector option)

MODEL GP, PROFILE-STYLE SENSOR WITH STYLE V CAPTIVE-SLIDING MAGNET

Drawing is for reference only, contact applications engineering for tolerance specific information.

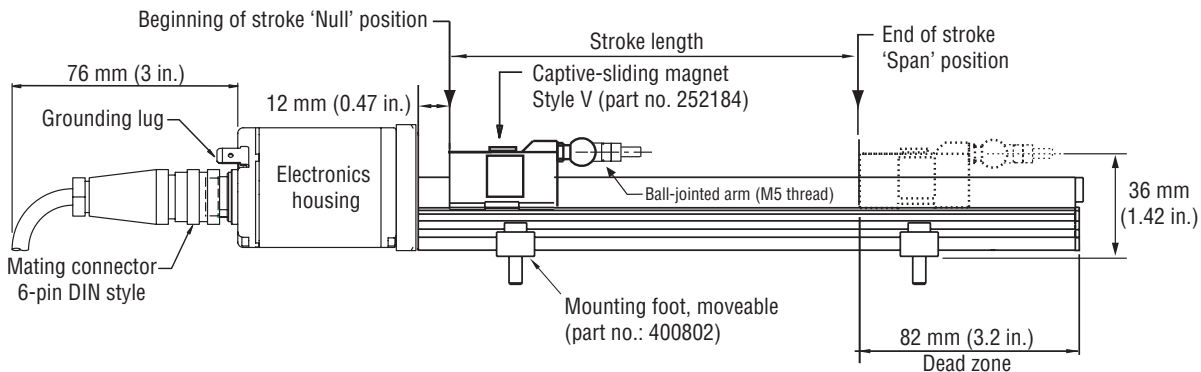

Figure 8. G-Series Model GP Profile-style sensor dimension reference (Shown with mating cable connector)

MODEL GP, PROFILE-STYLE SENSOR WITH STYLE M OPEN-RING MAGNET

Drawing is for reference only, contact applications engineering for tolerance specific information.

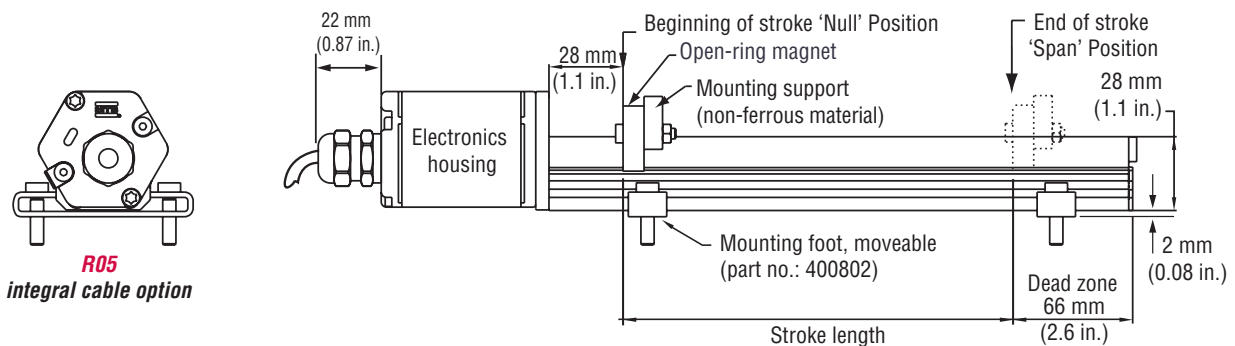

Figure 9. G-Series Model GP Profile-style sensor dimension reference (Shown with the **R05** integral cable option)

Standard magnet selections (Model GP)

SELECTION OF POSITION MAGNETS (ONE MAGNET INCLUDED WITH MODEL GP SENSOR)

A choice of two magnet mounting configurations are available with the profile-style sensor; A 'captive-sliding' magnet, *Styles S or V* or an 'open-ring' magnet, *Style M*. Captive-sliding magnets utilize slide bearings of special material that reduce friction, and if required, help mitigate dirt build up. The slide bearings are designed to operate dry, requiring no external lubrication or maintenance.

The *Style M* 'open-ring' magnet mounts on the moving machine part and travels just above the sensor's profile extrusion. The open-ring magnet requires a minimum distance away from ferrous metals to allow proper sensor output. It must be mounted using non-ferrous screws and a non-ferrous support bracket, or utilize a non-ferrous spacer of at least 5 mm (0.2 in.) thickness.

POSITION MAGNET SELECTIONS (Drawing dimensions are for reference only)

Magnet dimensions and mounted magnet dimensions	Description	Part number
<p>14 mm (0.55 in.)</p> <p>43 mm (1.69 in.)</p> <p>20 mm (0.79 in.)</p> <p>40 mm (1.58 in.)</p> <p>25 mm (1 in.)</p> <p>Rotation: Vertical: 18° Horizontal: 360°</p> <p>Ball-jointed arm (M5 thread)</p> <p>52 mm (2.05 in.)</p> <p>45 mm (1.77 in.)</p>	<p>Captive-sliding magnet, Style S For Model GP profile-style sensor</p>	<p>252182</p>
<p>14 mm (0.55 in.)</p> <p>57 mm (2.24 in.)</p> <p>25 mm (1 in.)</p> <p>40 mm (1.58 in.)</p> <p>Rotation: Vertical: 18°</p> <p>Ball-jointed arm (M5 thread)</p> <p>9 mm (0.35 in.)</p> <p>36 mm (1.41 in.)</p>	<p>Captive-sliding magnet, Style V For Model GP profile-style sensor</p>	<p>252184</p>
<p>60°</p> <p>14 mm (0.55 in.)</p> <p>25 mm (0.97 in.)</p> <p>21 mm (0.81 in.)</p> <p>2 Holes Each 4.3 mm (0.17 in.) dia. on 24 mm (0.94 in.) dia.</p> <p>Non-ferrous mounting support and screws</p> <p>21 mm (0.81 in.)</p> <p>Max gap 3 mm ± 1 mm (0.12 in. ± 0.04 in.)</p> <p>29 mm (1.14 in.)</p> <p>Open-ring magnet Style 'M'</p>	<p>Open-ring magnet, Style M I.D.: 13.5 mm (0.53 in.) O.D.: 33 mm (1.3 in.) Thickness: 8 mm (0.31 in.) Operating temperature: - 40 °C to 100 °C</p> <p>This magnet may influence the sensor performance specifications for some applications.</p>	<p>251416-2</p>

**Model GP Profile-Style Sensor
Mounting**

Model GP Sensor mounting

Model GP profile-style sensor mounting flexible installation in any position!

Temposonics Model GP profile-style sensors offer two basic mounting methods; side grooves for use with mounting feet or a bottom groove that accepts special T-Slot nuts. Both the mounting feet and T-Slot nuts can be positioned along the sensor extrusion to best secure the sensor for each particular application.

Notes:

1. Model GP sensors include two mounting feet (part no. 400802) for sensors stroke lengths up to 1250 mm (50 in.)
2. One additional mounting foot is included for stroke lengths over 1250 mm (50 in.) and for each additional 500 mm (20 in.), thereafter.
3. MTS recommends using 10-32 cap screws (*customer supplied*) at a maximum torque of 44 in. lbs. when fastening mounting feet.

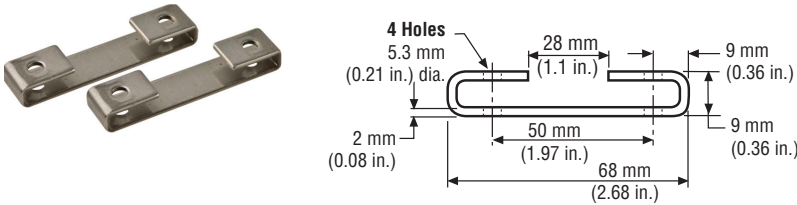
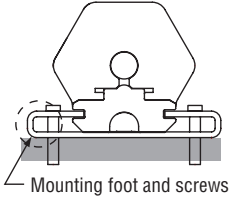
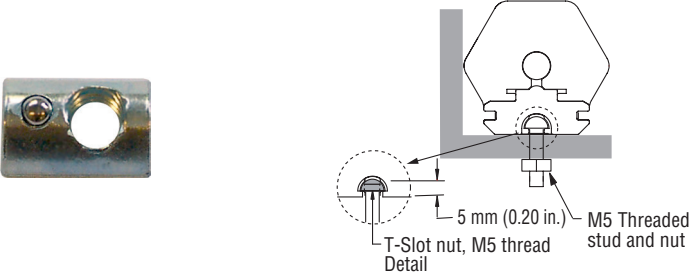
Profile-Style sensor mounting and installation reference	Mounting method	Part number
 <p>(Width = 14.5 mm (0.57 in.))</p>	<p>Mounting feet, standard (304 SS) Profile-style sensor mounting for sensor model GP</p>	<p>400802</p>
<p>10 - 32 Cap screws Recommended (Customer supplied)</p>  <p>Mounting foot and screws</p>	<p>Mounting feet and screws Profile-style sensor foot installation</p>	<p>See Mounting Feet part number: 400802</p>
 <p>T-Slot nut, M5 thread Detail</p> <p>5 mm (0.20 in.)</p> <p>M5 Threaded stud and nut</p>	<p>T-Slot nut Nut for mounting model GP sensor M5 thread (Optional, ordered separately)</p>	<p>401602</p>

Model GH rod-style sensor dimension references

The Temposonics G-Series rod-style sensor (Model GH) offers modular construction, flexible mounting configurations, and easy installation. The Model GH sensor is designed for mounting in applications where high pressure conditions exist (5000 psi continuous, 10,000 psi spike) such as inside hydraulic cylinders. The Model GH sensor may also be mounted externally in many applications.

Stroke-dependent Dead Zones:	
Stroke length:	Dead zone:
50 mm (2 in.) - 5000 mm (197 in.)	63.5 mm (2.5 in.)
5005 mm (197.1 in.) - 7620 mm (300 in.)	66 mm (2.6 in.)

MODEL GH, ROD-STYLE SENSOR WITH RING MAGNET (MAGNET ORDERED SEPARATELY)

Drawing is for reference only, contact applications engineering for tolerance specific information.

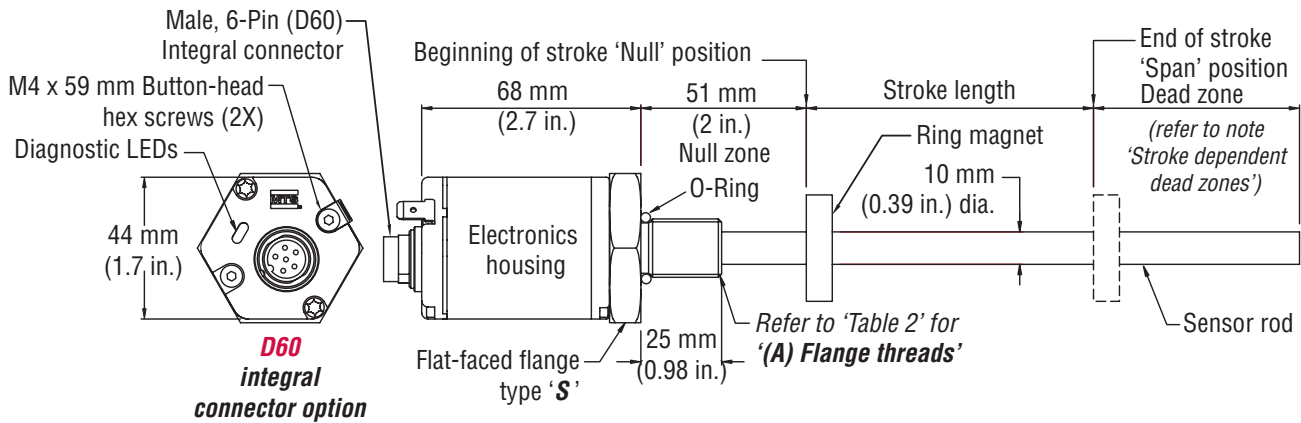

Figure 10. Model GH Rod-style sensor dimension reference (shown with **D60** integral connector option)

MODEL GH, ROD-STYLE SENSOR WITH 6-PIN DIN MATING CABLE CONNECTOR (MAGNET ORDERED SEPARATELY)

Drawing is for reference only, contact applications engineering for tolerance specific information.

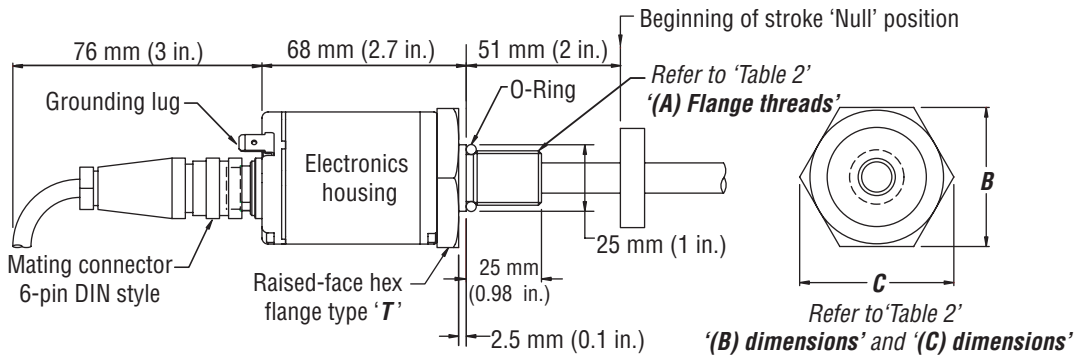

Figure 11. Model GH Rod-style sensor dimension reference (shown with mating cable connector)

Housing style Flange type	Description	(A) Flange threads	(B) Dimensions	(C) Dimensions
T	US customary threads with raised-face flange	3/4" - 16 UNF-3A	1.75 in.	2 in.
S	US customary threads with flat-faced flange	3/4" - 16 UNF-3A	1.75 in.	2 in.
M	Metric threads with flat-faced flange	M18 x 1.5	46 mm	53 mm

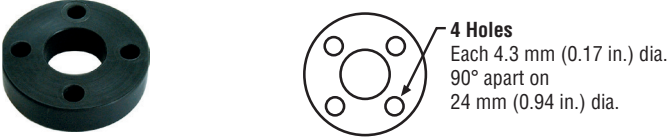
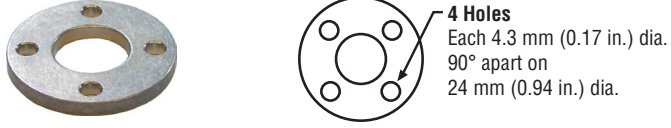

Table 2. Model GH Rod-style sensor housing style and flange type references

**Models GH Rod-Style Sensor
Standard Magnet Selections**

Standard magnet options (Model GH)

Magnets must be ordered separately with Model GH position sensors. The standard ring magnet (part number 201542-2) is suitable for most applications.

POSITION MAGNET SELECTIONS (Magnet must be ordered separately) *(Drawing dimensions are for reference only)*

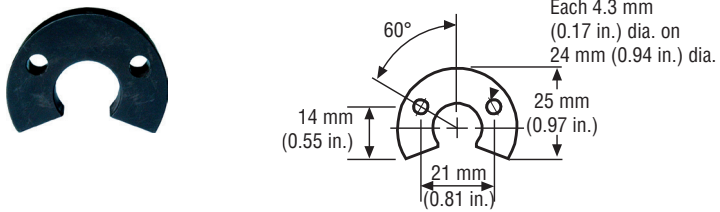
Magnet and magnet dimensions	Description	Part number
	<p>Standard ring magnet</p> <p>I.D.: 13.5 mm (0.53 in.) O.D.: 33 mm (1.3 in.) Thickness: 8 mm (0.3 in.) Operating temperature: - 40 °C to 100 °C</p>	201542-2
	<p>Magnet spacer</p> <p>(Non-ferrous, use with ring magnet Part number: 201542-2) I.D.: 14 mm (0.56 in.) O.D.: 32 mm (1.25 in.) Thickness: 3.2 mm (0.125 in.)</p>	400633
	<p>Ring magnet</p> <p>I.D.: 13.5 mm (0.53 in.) O.D.: 25.4 mm (1 in.) Thickness: 8 mm (0.3 in.) Operating temperature: - 40 °C to 100 °C</p>	400533
	<p>Open-ring magnet, Style M</p> <p>I.D.: 13.5 mm (0.53 in.) O.D.: 33 mm (1.3 in.) Thickness: 8 mm (0.3 in.) Operating temperature: - 40 °C to 100 °C</p> <p>This magnet may influence the sensor performance specifications for some applications.</p>	251416-2

MAGNET FLOAT SELECTION *(Drawing dimensions are for reference only)*

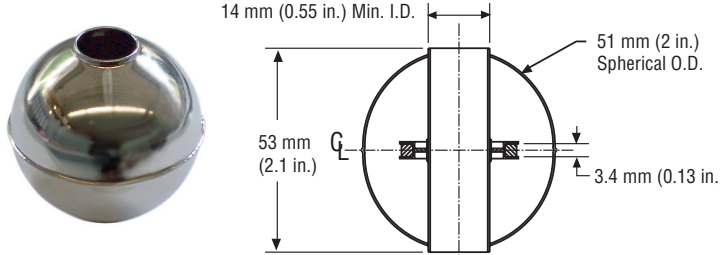
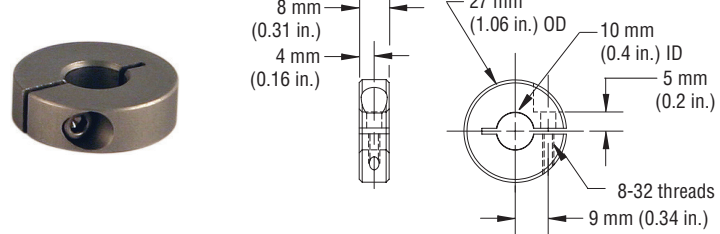
	<p>Magnet float</p> <p>(Level sensing applications) Specific gravity: 0.70 maximum Pressure: 870 psi maximum</p> <p>(This float is used with Model GH rod-style sensors for hydraulic fluid or fresh water applications only). Collar (part no.: 560777) is recommended for end of stroke stops.</p>	251447
	<p>Collar</p> <p>Provides end of stroke stops for magnet float (part no.: 251447)</p>	560777

Model GH Rod-Style sensor mounting

The position magnet requires minimum distances away from ferrous metals to allow proper sensor output. The minimum distance from the front of the magnet to the cylinder end cap is 15 mm (0.6 in.).

The minimum distance from the back of the magnet to the piston head is 3.2 mm (0.125 in.). However, a minimum distance of at least 5 mm (0.197 in.) is preferred for added performance margin. The non-ferrous spacer part no.: 400633 provides this minimum distance when used along with the standard ring magnet (part no.: 201542-2) as shown in *Figure 12*.

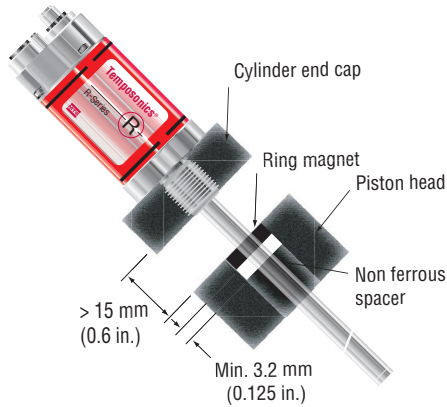

Figure 12. Model GH rod-style mounting

Cylinder installation

When used for direct-stroke measurement in fluid cylinders, the sensor's high pressure, stainless steel rod installs into a bore in the piston head/rod assembly as shown in *Figure 13*. This method guarantees a long-life and trouble-free operation.

The sensor cartridge can be removed from the flange and rod housing while still installed in the cylinder. This procedure allows quick and easy sensor cartridge replacement, without the loss of hydraulic pressure.

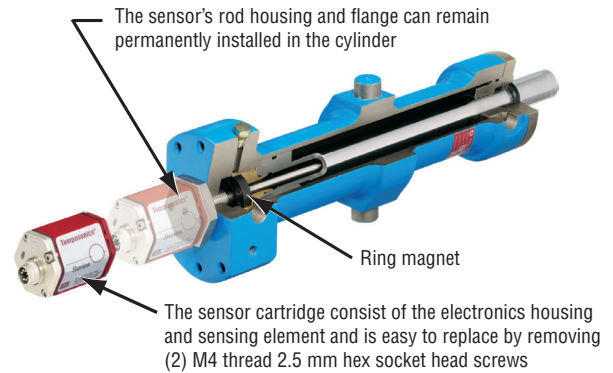

Figure 13. Fluid cylinder installation

Models GP and GH Rod-Style Sensors
Connections and Wiring

Connections and wiring

STANDARD MALE (D60) 6-PIN DIN INTEGRAL CONNECTOR (M16)

Male, 6-pin (D60) integral connector pin-out as viewed from the end of the sensor.



Important Notes:

1. A grounding lug on the end of the sensor is provided for convenient connection to earth ground.
2. Appropriate grounding of cable shield is required at the controller end.
3. For analog output sensors, the yellow wire (pin 3) and green wire (pin 4) provide serial communications. If possible, during sensor installation these wires should be placed for easy access if future programming or diagnostics are needed. When these wires are not used, they should be isolated with electrical tape to avoid unintended contact with other nearby wires or machine surfaces.

Pin Number	Wire Color	Function / Digital-pulse outputs	Function / Analog outputs
1	Gray	(-) Gate for PWM (-) Stop for Start/Stop or programming (RS-422 TX-)	0 to 10, -10 to +10 Vdc or 4 to 20 mA, 0 to 20 mA or reverse acting: 10 to 0, 10 to -10 Vdc or 20 to 4 mA, 20 to 0 mA
2	Pink	(+) Gate for PWM (+) Stop for Start/Stop or programming (RS-422 TX+)	Return for pin 1
3	Yellow	(+) Interrogation for PWM (+) Start for Start/Stop or Programming (RS-422 RX+)	Programming (RS-485+)
4	Green	(-) Interrogation for PWM (-) Start for Start/Stop or Programming (RS-422 RX-)	Programming (RS-485-)
5	Red or Brown	Supply voltage (+Vdc)	Supply voltage (+Vdc)
6	White	DC ground (for supply)	DC ground (for supply)





Table 2. Wiring, Male, 6-pin (D60) integral connector

Cable connector Options (field installable) 6-pin DIN (D60) female (Drawing dimensions are for reference only)

Connector and connector dimensions	Description	Part number
	<p>Cable Connector, Female, Straight Exit (Field installable)</p> <p>6-Pin DIN (D60) Mates with standard male (M16) integral connector</p>	560700
	<p>Cable Connector, Female, 90° Exit (Field installable)</p> <p>6-Pin DIN (D60) Mates with standard male (M16) integral connector</p>	560778

**Models GP and GH Sensors, Connections and Wiring
Extension Cables with Connectors**

EXTENSION CABLE WITH CONNECTORS FOR D6 (D60) CONNECTION TYPES

Extension Cable and Connector	Description	Connection type
	Female Connector, Straight Exit with Standard PVC Jacket Cable <i>(Assembly Includes D6 Connector, Part No.: 560700 and Cable, Part No.:530026)</i>	D6
	Female Connector, 90° Exit with Standard PVC Jacket Cable <i>(Assembly Includes D6 Connector, Part No.: 560778 and Cable, Part No.:530026)</i>	DA
	Female Connector, Straight Exit with Black Polyurethane Jacket Cable (for higher resistance to moisture, oil and cold temperatures) <i>(Assembly Includes D6 Connector, Part No.: 560700 and Cable, Part No.:530045)</i>	DJ
	Female Connector, 90° Exit with Black Polyurethane Jacket Cable (for higher resistance to moisture, oil and cold temperatures) <i>(Assembly Includes D6 Connector, Part No.: 560778 and Cable, Part No.:530045)</i>	DK

Ordering Information
Extension Cable with Connector for D6 (D60) Connection Types

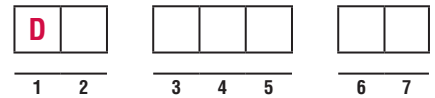

SENSOR CONNECTION TYPES

- D6** = Female connector, straight exit (part no. 560700), and PVC jacket cable (part no. 530026)
- DA** = Female connector, 90° exit (part no. 560778), and PVC jacket cable (part no. 530026)
- DJ** = Female connector, straight exit (part no. 560700), and black polyurethane jacket cable (part no. 530045)
- DK** = Female connector, 90° exit (part no. 560778), and black polyurethane jacket cable (part no. 530045)

CABLE LENGTHS

For standard length cables up to 100 ft

- 005** = 5 ft
- 015** = 15 ft
- 025** = 25 ft
- 050** = 50 ft
- 100** = 100 ft

For custom length cables over 100 ft

___ = Cable length (maximum cable length is dependent on the output selected; consult MTS Applications Engineering)

CABLE TERMINATION

- P0** = Pigtail cable without connector (2 digit code)
- D6M** = D6 male connector (straight exit). Only available with the **D6** option above.
- D6F** = D6 female connector (straight exit). Only available with the **D6** option above.
- DAF** = D6 female connector (90° exit). Only available with the **DA** option above.

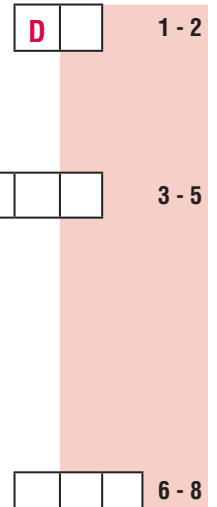

G-Series Models GP and GH Sensors Connections and Wiring

Retrofit/replacement references - integral adapter cables with in-line connectors

Tables 4 and 5 describe a variety of retrofit connection options for analog and digital-pulse sensors to provide direct backward compatibility for your application.

ANALOG OUTPUT

Important Notes (Table 4):

1. This format used to show the voltage and current output range is: [Value at Null (Setpoint 1) to [Value at Span (setpoint 2)]. Not all of the available output ranges for voltage are shown.
2. When replacing a L-Series sensor with a G-Series sensor, and reverse-acting output is being used, the wire connections must be changed at the controller. Refer to the *G-Series Cross Reference, document part no.: 550967* for detailed information.
3. If possible, during sensor installation, these wires should be placed for easy access if future programming or diagnostics are needed. When these wires are not used, they should be isolated with electrical tape to avoid unintended contact with other nearby wires or machine surfaces.

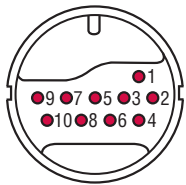

Male, 10-pin In-line
RB connector (Option RB_)



Male, 10-pin in-line or
integral MS connector
(Option FM_ or MS0)

DIGITAL-PULSE (START/STOP OR PWM) OUTPUTS

Important Notes (Table 5):

The G-Series sensor can provide a square wave neuter output for backwards compatibility to replace Temposonics I, Temposonics II, and L-Series sensors that produced a neuter output signal. The neuter output option was used for connection to the Analog Output module (AOM), Digital Interface Box (DIB), and to some custom interface/controllers. Reference the G-Series Cross Reference, document part no. 550967, for neuter output connection information, including adapter cables and field-installed connections.

‡ When using PWM output with internal interrogation, both interrogation input signals are not used. Therefore, the designated connector pin(s) can be left unconnected or connected to ground.

Analog output connections (voltage or current)

In-line RB connector (Option RB_)	in-line MS connector (Option FM_)	integral MS connector (Option MS0)	Function / Analog output (see Note 1)
Pin number	Pin number	Pin number	
4	D	D	0 to 10, -10 to +10 Vdc or 4 to 20 mA, 0 to 20 mA or reverse acting (see Note 2): 10 to 0, +10 to -10 Vdc or 20 to 4 mA, 20 to 0 mA
3	C	C	Ground for Signal Return
7	G	G	Programming (RS-485+) (See Note 3)
8	H	H	Programming (RS-485-) (See Note 3)
5	E	E	Supply voltage (+Vdc)
1	A	A	DC ground (for supply)
2	B	B	No connection
6	F	F	No connection
9	J	J	No connection
10	K	K	No connection

Table 4. Intergal adapter cable connections (analog output)

Digital-pulse output connections (Start/Stop or PWM)

In-line RB connector (Option RB_)	in-line MS connector (Option FM_)	Integral MS connector (Option MS0)	Function / Digital-pulse output
Pin Number	Pin number	Pin number	
3	C	C	(-) Gate for PWM (-) Stop for Start/Stop or programming (RS-422 TX-)
4 and 8	D	D	(+) Gate for PWM (+) Stop for Start/Stop or programming (RS-422 TX+)
9	G	G	(+) Interrogation for PWM ‡ (+) Start for Start/Stop or Programming (RS-422 RX+)
10	H	H	(-) Interrogation for PWM ‡ (-) Start for Start/Stop or Programming (RS-422 RX-)
5	E	E	Supply voltage (+Vdc)
1	A	A	DC ground (for supply)
2	B	B	No connection
6	F	F	No connection
7	J	J	No connection
-	K	K	No connection

Table 5. Intergal adapter cable connections (analog output)

**Models GP and GH Sensors
Ordering Information (Continued)**

G														
1	2	3	4	5	6	7	8	9	10	11	12	13	14	15

Choose output option from below (2 to 3 digit code) _____ =

--	--	--

13 - 15

Choose a value described below to encode in 2 to 3 digits (sensor part number boxes 13-15)

Voltage

- | | | |
|----------------------------|--------------------------|--------------------------|
| V0 = 0 to +10 Vdc | V4 = 0 to +5 Vdc | V8 = -5 to +5 Vdc |
| V1 = +10 to 0 Vdc | V5 = +5 to -5 Vdc | V9 = +5 to 0 Vdc |
| V2 = -10 to +10 Vdc | V6 = -10 to 0 Vdc | |
| V3 = +10 to -10 Vdc | V7 = 0 to -10 Vdc | |

Current

- | | |
|------------------------|------------------------|
| A0 = 4 to 20 mA | A2 = 0 to 20 mA |
| A1 = 20 to 4 mA | A3 = 20 to 0 mA |

Digital pulse

- RO X** = Start/Stop. If more than one magnet, the X denotes the number of magnets in hexadecimal (2 to F).
- RF X** = Start/Stop with Closed-Error Signal Utility (see 'Note 7'). If more than one magnet, the X denotes the number of magnets in hexadecimal (2 to F).
- DI X** = PWM, internal interrogation, the X denotes the number of circulations in hexadecimal (1 to F), and G = 16, K = 20 circulations.
- FI X** = PWM, internal interrogation with Closed Error Signal Utility (see 'Note 7').The X denotes the number of circulations in hexadecimal (1 to F), and G = 16 to K = 20 circulations.
- DE X** = PWM, external interrogation, the X denotes the number of circulations in hexadecimal (1 to F), and G = 16, K = 20 circulations.
- FE X** = PWM, external interrogation with Closed Error Signal Utility (see 'Note 7').The X denotes the number of circulations in hexadecimal (1 to F), and G = 16 to K = 20 circulations.
- NO X** = Start/Stop output wired for square wave neuter (" + Stop" used for neuter output pulse). If more than one magnet, the X denotes the number of magnets in hexadecimal (2 to F) (see 'Note 5').

Notes:

1. Polyurethane jacketed cable for use where higher resistance to moisture, oil, and other environmental conditions are required.
2. Wired for analog, digital-pulse, or neuter, depending on output selected. For Temposonics II and model LH replacements/ retrofits only. Refer to G-Series Cross Reference part numbers 550967 and 550956 for more information.
3. Wired for analog and digital-pulse depending on output selected. Use for model LH replacements or retrofits. Refer to the G-Series Cross Reference document, part number 550956 for more information.
4. Selected when retrofitting sensors with ± 15 Vdc input voltages.
5. For Temposonics I, Temposonics II, and model LH neutered output sensor retrofits only. Refer to the G-Series Cross Reference documents, part numbers 550956 and 550967 for more information.
6. Stroke lengths longer than 2540 mm (100 in.) for analog outputs are available on a custom basis.
7. When shock and vibration events exceed the sensor specification rating, the Closed Error Signal Utility (option "F") will provide either PWM or Start/ Stop outputs, which are backwards compatible to interface cards/controllers designed for the legacy Temposonics II and L-Series sensor models. For more information about the Closed Error Signal Utility (option "F"), refer to Application Note, part number 550983.
8. The High Vibration-Resistant (HVR) option provides the model GH rod-style sensors with increased resistance to shock and vibration for use in heavy duty machinery. Refer to "G-Series and R-Series Sensors for High Shock and Vibration Applications", part no. 551073 for more information.

Reference table

Decimal:	1	2	3	4	5	6	7	
Hexadecimal:	1	2	3	4	5	6	7	
Decimal:	8	9	10	11	12	13	14	15
Hexadecimal:	8	9	A	B	C	D	E	F

Document Part number:
550959 Revision G (EN) 09/2015



LOCATIONS

USA
MTS Systems Corporation
Sensors Division
3001 Sheldon Drive
Cary, N.C. 27513, USA
Tel. +1 919 677-0100
Fax +1 919 677-0200
info.us@mtssensors.com
www.mtssensors.com

GERMANY
MTS Sensor Technologie
GmbH & Co. KG
Auf dem Schüffel 9
58513 Lüdenscheid, Germany
Tel. +49 2351 9587-0
Fax +49 2351 56491
info.de@mtssensors.com
www.mtssensors.com

JAPAN
MTS Sensors Technology Corp.
737 Aihara-machi,
Machida-shi,
Tokyo 194-0211, Japan
Tel. +81 42 775-3838
Fax +81 42 775-5512
info.jp@mtssensors.com
www.mtssensors.com

FRANCE
MTS Systems SAS
Zone EUROPARC Bâtiment EXA 16
16/18, rue Eugène Dupuis
94046 Creteil, France
Tel. +33 1 58 4390-28
Fax +33 1 58 4390-03
info.fr@mtssensors.com
www.mtssensor.com

ITALY
MTS Systems Srl. Sensor Division
Via Diaz,4
25050 Provaglio d'Iseo (BS), Italy
Tel. +39 030 988 3819
Fax +39 030 982 3359
info.it@mtssensors.com
www.mtssensors.com

CHINA
MTS Sensors
Room 504, Huajing Commercial Center,
No. 188, North Qinzhou Road
200233 Shanghai, China
Tel. +86 21 6485 5800
Fax +86 21 6495 6329
info.cn@mtssensors.com
www.mtssensors.com

LEGAL NOTICES

MTS, Temposonics and Level Plus are registered trademarks of MTS Systems Corporation. All other trademarks are the property of their respective owners. Printed in USA. Copyright © 2015 MTS Systems Corporation. All Rights Reserved in all media.

All specifications are subject to change. Contact MTS for specifications and engineering drawings that are critical to your application. Drawings contained in this document are for reference only. Go to <http://www.mtssensors.com> for the latest product information.