

# Temposonics®

Magnetostrictive, Absolute, Non-contact  
Linear-Position Sensors



**E-Series Models EP and EL**  
Analog and Start/Stop Outputs

Document Part Number:  
551248 Revision A

## Data Sheet



**Model EP position sensor - Full Size Profile Housing**  
Stroke Length: 50 mm to 3000 mm (2 in. to 120 in.)

**Model EL position sensor - Low Height Profile Housing**  
Stroke Length: 50 mm to 2500 mm (2 in. to 100 in.)

### FEATURES

- Linear, Absolute Measurement
- Non-Contact Sensing Technology
- Linearity Deviation Less Than 0.02% F.S.
- Repeatability Within 0.005% F.S.
- Two Outputs Available:
  - Analog (Voltage/Current) Forward or Reverse Acting
  - Start/Stop Output
- Simple Sensor Parameter Upload (for Start/Stop)
- Stroke Length Ranges:
  - 50 mm to 2500 mm (2 in. to 100 in.)
  - 50 mm to 3000 mm (2 in. to 120 in.)*For Model EP Start/Stop*
- EMI Shielded and CE Certified

### BENEFITS

- Rugged, Cost Effective, Precise and Durable Non-wear Alternative to Potentiometers
- Simultaneous Multi-position Measurements
- Over Voltage Protection to 36 Vdc and Polarity Protection up to -30 Vdc

### APPLICATIONS

- Continuous Operation In Harsh Industrial Conditions

### TYPICAL INDUSTRIES

- Factory Automation
- Woodworking and Metal Forming
- Material Handling and Packaging

### Time-based Magnetostrictive position sensing principle

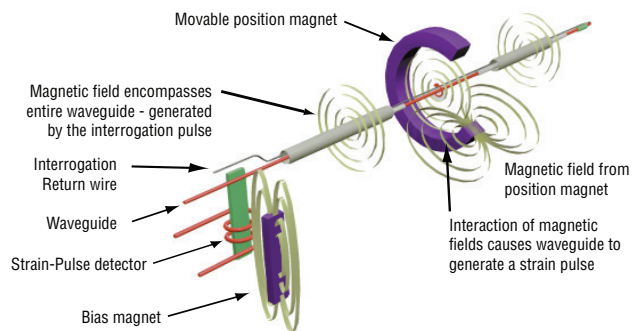

### Benefits of Magnetostriction

Temposonics linear-position sensors use the time-based magnetostrictive position sensing principle developed by MTS. Within the sensing element, a sonic-strain pulse is induced in a specially designed magnetostrictive waveguide by the momentary interaction of two magnetic fields. One field comes from a movable permanent magnet that passes along the outside of the sensor. The other field comes from an “interrogation” current pulse applied along the waveguide. The resulting strain pulse travels at sonic speed along the waveguide and is detected at the head of the sensing element.

The position of the magnet is determined with high precision and speed by accurately measuring the elapsed time between the application of the interrogation pulse and the arrival of the resulting strain pulse with a high-speed counter. The elapsed time measurement is directly proportional to the position of the permanent magnet and is an absolute value. Therefore, the sensor's output signal corresponds to absolute position, instead of incremental, and never requires recalibration or re-homing after a power loss. Absolute, non-contact sensing eliminates wear, and guarantees the best durability and output repeatability.

All specifications are subject to change. Contact MTS for specifications and engineering drawings that are critical to your application. Drawings contained in this document are for reference only. Go to <http://www.mtssensors.com> for the latest product documentation and related media.

## E-Series Models EP and EL Sensors Product Overview/Specifications

### Product overview

MTS Sensors continues to establish new performance standards for low-cost, fully-industrial, durable position sensors using the widely preferred magnetostrictive technology. This principle for accurate and non-contact measurement of linear-position sensing was developed 30 years ago by MTS and is used with outstanding success in a large variety of industrial applications.

The Temposonics models EP and EL sensors consists of robust aluminum profile-style housings that offer flexible mounting configurations and easy installation. Sensor models EP and EL are ideal for demanding industrial applications where simple, reliable non-contact feedback is essential.

### Product specifications

Parameters	Specifications	Parameters	Specifications
<b>OUTPUT</b>		<b>ELECTRONICS</b>	
<b>Measured output variables:</b>	Position	<b>Operating voltage:</b>	<b>+24 Vdc nominal:</b> -15% or +20%* <b>Polarity protection:</b> up to -30 Vdc <b>Over voltage protection:</b> up to 36 Vdc <b>Current drain:</b> Analog: 50 - 140 mA Start/Stop: 50 - 100 mA <i>(Stroke length dependent)</i> <b>Dielectric withstand voltage:</b> 500 Vdc (DC ground to machine ground)
<b>Resolution:</b>	<b>Analog:</b> Infinite (restricted by output ripple) <b>Start/Stop:</b> 0.1, 0.01 and 0.005 mm (controller dependent)	<b>ENVIRONMENTAL</b>	
<b>Linearity deviation:</b>	< ± 0.02% full stroke (minimum ± 60 µm)	<b>Operating conditions:</b>	<b>Operating temperature:</b> -40 °C (-40 °F) to 75 °C (167 °F) <b>Relative humidity:</b> 90% no condensation <b>Ingress protection:</b> IP 67** <i>(when mating connector is correctly fitted)</i>
<b>Repeatability:</b>	< ± 0.005% full stroke (minimum ± 20 µm)	<b>EMC test:</b>	<b>Electromagnetic emission:</b> EN 61000-6-4 <b>Electromagnetic susceptibility:</b> EN 61000-6-2, This sensor meets the EC directive requirements and is marked with CE.
<b>Outputs:</b>	<b>Analog (voltage or current) Voltage:</b> 0 to 10 Vdc or 10 to 0 Vdc or <b>Two outputs:</b> 0 to 10 Vdc and/or 10 to 0 Vdc (controller input resistance RL ≥ 5k Ohm) <b>Current:</b> 4 to 20 mA or 20 to 4 mA (Controller input resistance RL ≤ 500 Ohm)	<b>Shock rating:</b>	100 g (single hit)/ IEC standard EN 60068-2-27
<b>Stroke length:</b>	<b>Digital-pulse (Start/Stop):</b> RS-422 differential signal <b>Serial parameter upload available for:</b> Measuring range, offset, gradient, status and manufacturer number <b>Range:</b> 50 mm to 2500 mm (2 in. to 100 in.) <b>or</b> 50 mm to 3000 mm (2 in. to 120 in.) <i>For Model EP Start/Stop output</i>	<b>Vibration rating:</b>	15 g/10 to 2000 Hz, IEC standard EN 60068-2-6 (resonance frequencies excluded)
		<b>WIRING</b>	
		<b>Connection types:</b>	<b>Analog output:</b> 5-pin (M12) male integral connector <b>Start/Stop output:</b> 8-pin (M12) male integral connector
		<b>PROFILE-STYLE SENSOR</b>	
		<b>Electronic head:</b>	Aluminum housing
		<b>Sensor extrusion:</b>	Aluminum (Temposonics profile style)
		<b>Mounting:</b>	Adjustable mounting clamps
		<b>Magnet types:</b>	Captive-sliding magnets, open-ring magnet or block magnet

\* UL Recognition requires an approved power supply with energy limitation UL 61010-1), or Class 2 rating according to the National Electrical Code (USA) / Canadian Electrical Code.

\*\* The IP rating is not part of the UL Recognition.

## Outputs

### ANALOG (VOLTAGE/CURRENT) OUTPUTS

Analog outputs include voltage (0 to 10 Vdc forward or reverse acting), and current (4 to 20 mA forward or reverse acting). Since the outputs are direct, no signal conditioning electronics are needed when interfacing with controllers or meters (see 'Figure 1').

#### Analog output voltages ranges:

- 0 to 10 Vdc
- 10 to 0 Vdc
- 0 to 10 Vdc and 10 to 0 Vdc
- 4 to 20 mA
- 20 to 4 mA

### DIGITAL START/STOP OUTPUT

Temposonics E-Series Models EP and EL Start/Stop output sensors require a start signal from a controller or interface module to initiate the measurement cycle. The sensor generates a stop signal at the end of the measurement cycle that is used to stop the controller's counter clock.

The elapsed time between the Start and Stop signals is directly proportional to the magnet's position along the active stroke length. The controller can calculate the absolute position of the magnet from the time value and the sensor's unique gradient value (inverse of the speed for the sonic pulse traveling in the sensor's waveguide). (see 'Figure 2').

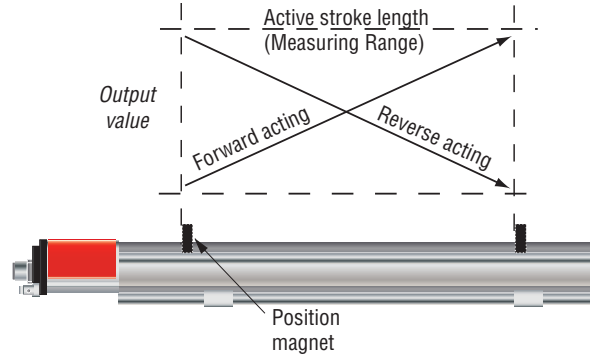

Figure 1. Analog Output signals

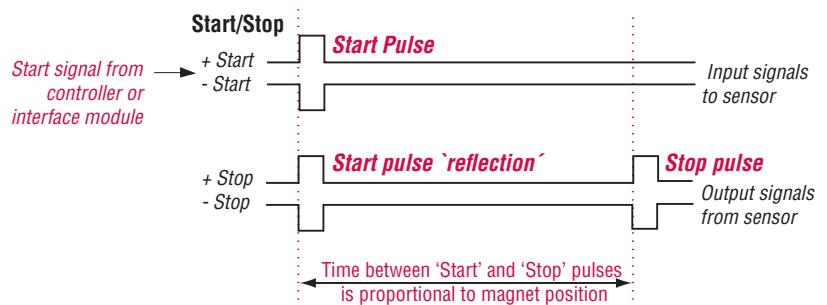

Figure 2. Start/Stop output signals (RS-422 differential pairs)

## Dual magnet outputs

### MEASUREMENT OPTIONS

E-Series sensors provide options for simultaneous multi-position measurements by using more than one magnet per sensor. When using Start/Stop sensor output the ability to process multiple magnets depends on the capability of the controller or interface module that is used. When using analog type outputs (voltage or current) the sensor is limited to a maximum of two magnets.

For analog output types the options for single-magnet or dual-magnets is specified in the sensor model number when ordered. For single-magnet sensors the sensor's full active stroke length is utilized by the one magnet. For example when using forward-acting outputs, the output is 0% of its value when the magnet is at the null position (start of stroke) and 100% of its value when at the edge of the dead zone (end of stroke), (see 'Figure 3').

However, for dual-magnet sensors the sensor's active stroke length must be shared by the two magnets, and a separation  $\geq 75$  mm (3 in.) must be maintained between the two magnets (front side of the first magnet to front side of the second magnet). This minimum distance between magnets is needed to maintain proper sensor output. Therefore, for the second magnet the start of stroke (0% output) is set at 75 mm away from the sensor's null position. Likewise, for the first magnet the end of stroke (100% output) is now set 75 mm away from the edge of the dead zone (see 'Figure 3').

The result of using the dual-magnet E-Series options is that the stroke length available for each magnet is 75 mm less (or 3 inches less when specifying stroke length in inches) than the sensor's full active stroke length as indicated in the model number.

When ordering the single-magnet E-Series sensor the minimum stroke length available is 50 mm or 2 inches. However when ordering dual magnet E-Series sensors the minimum stroke length available is 125 mm (i.e. 50 mm minimum, plus 75 mm for the minimum distance between magnets). Likewise, when specifying stroke length in inches the minimum stroke length available is 5 inches (i.e. 2 inch minimum, plus 3 inches for the minimum distance between magnets).

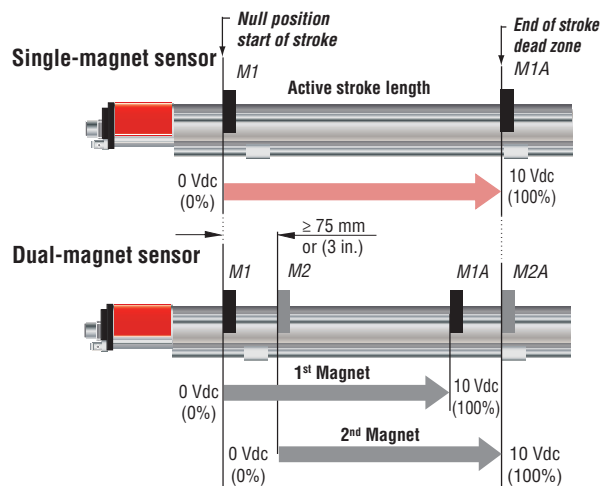

Figure 3. Single and dual magnet measurements

**E-Series Models EP and EL Sensors**  
**Sensor Communications and Dimension References**

**Communication**

**SENSOR PARAMETER UPLOAD FEATURE**

For applications using smart sensor interfaces, the Models EP and EL sensors with Start/Stop output (*Option R3*) comes with the ability to perform sensor parameter uploads. This feature replaces the task of entering sensor data manually, saving time and preventing possible entry errors during start-up or for system maintenance.

**Note: Start/Stop output (option R3)**

When the sensor parameter upload feature is not activated the Start/Stop output (*Option R3*) remains fully compatible with the Start/Stop output (*Option R0*) used in the previous generation E-Series sensors.

The upload feature supports the following sensor parameters:

- Measuring range
- Offset
- Gradient - (Shown as speed of the sonic-strain pulse (m/s) or inverse speed (μs/in.)
- Status
- Manufacturer number

The sensor's specific parameters can be retrieved by the controller/interface module at any time, via the sensor's Start/Stop signal lines.

The sensor parameter upload feature requires a customer supplied RS-422 interface. The data format is serial, 4800 Baud, 8-bit data length. Please contact the factory for additional parameter upload protocol details.

**Sensor dimension references**

Drawings are for reference only, contact applications engineering for tolerance specific information.

A robust aluminum extrusion forms the sensor housing containing the sensing element and electronics. The position magnet moves along the top of the profile extrusion housing.

**MODEL EP**

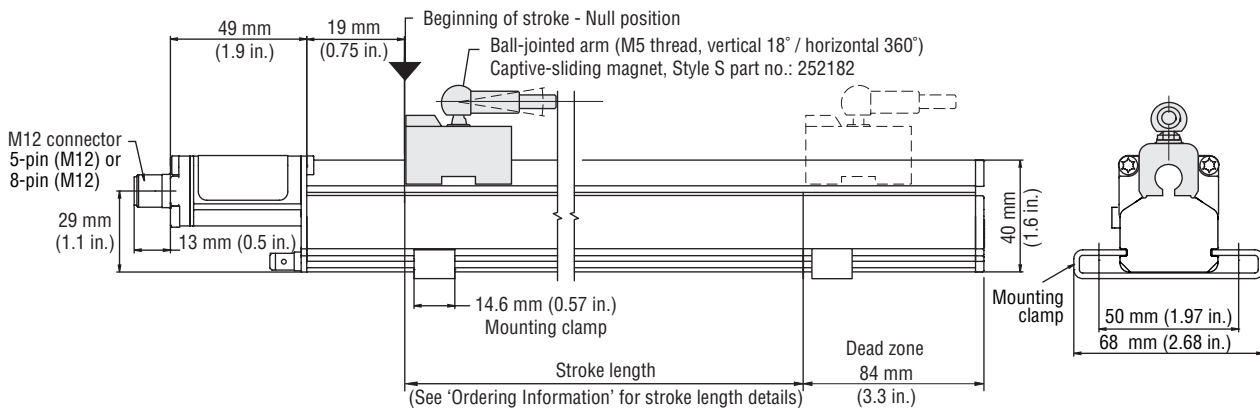

**Figure 4.** E-Series model EP sensor dimension reference (Shown with Style S captive-sliding magnet)

**MODEL EL**

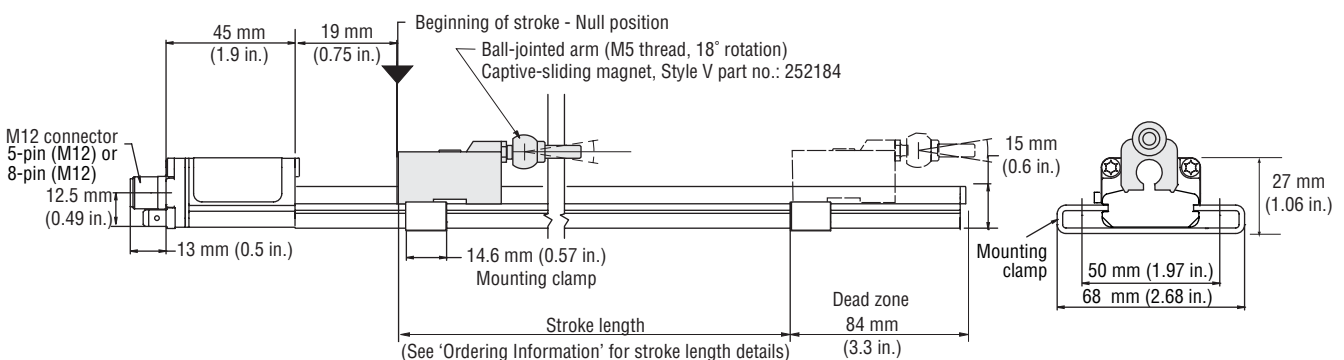

**Figure 5.** E-Series model EL sensor dimension reference (Shown with Style V captive-sliding magnet)

## Sensor dimension references

Drawings are for reference only, contact applications engineering for tolerance specific information.

### MODEL EP

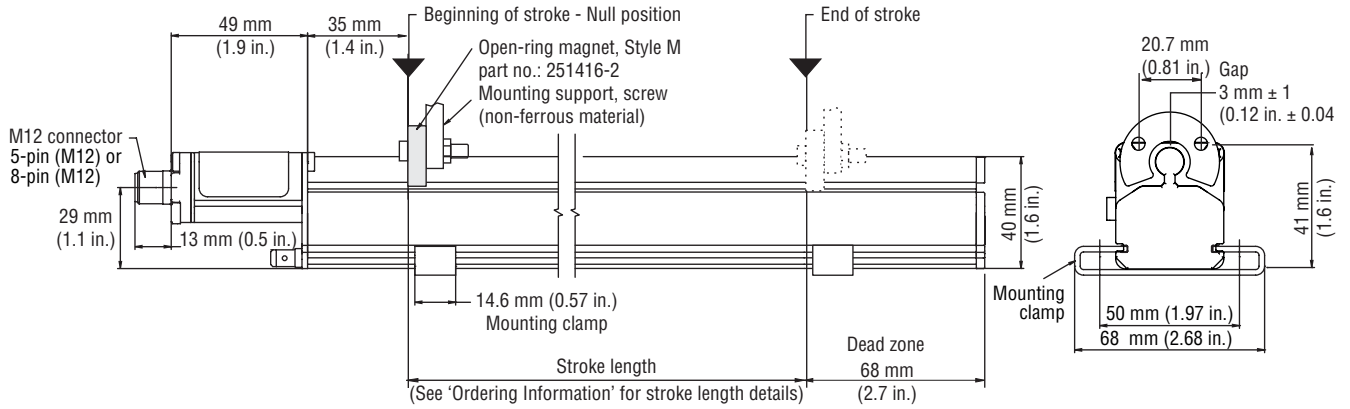

Figure 6. E-Series model EP sensor dimension reference (Shown with Style M open-ring magnet)

### MODEL EP

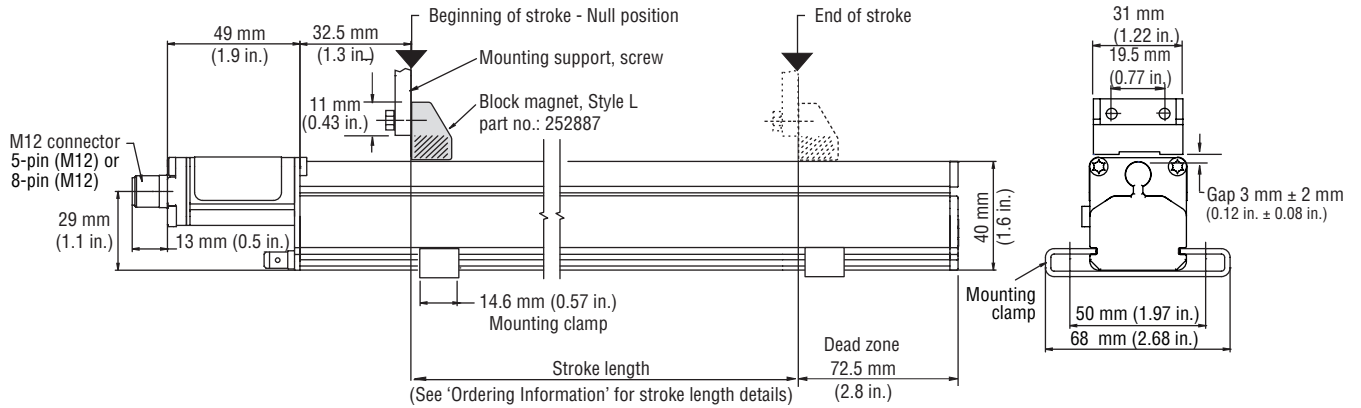

Figure 7. E-Series model EP sensor dimension reference (Shown with Style L block magnet)

**E-Series Models EP and EL Sensors**  
**Standard Magnet and Accessory Selections**

**Standard magnet selections (Models EP and EL)**

**Selection of position magnets**





A choice of four standard magnet mounting configurations are available for E-Series models EP and EL sensors; A 'captive-sliding' magnet (Styles S or V), or an 'open-ring' magnet (Style M), or the 'block' magnet (Style L). Captive-sliding magnets utilize slide bearings of special material that reduce friction, and if required, help mitigate dirt build up. The slide bearings are designed to operate dry, requiring no external lubrication or maintenance.

The Style M 'open-ring' magnet mounts on the moving machine part and travels just above the sensor's profile extrusion. The open-ring magnet requires a minimum distance away from ferrous metals to allow proper sensor output. It must be mounted using non-ferrous screws and a non-ferrous support bracket, or utilize a non-ferrous spacer of at least 5 mm (0.2 in.) thickness.

The Style L 'block' magnet (part no.: 252887), mounts on the moving machine part and travels just above the sensor's extrusion. The magnet can be mounted using ferrous metal screws on a customer supplied mounting plate or flat surface of the machine's moving part. The mounting plate or machine's moving part can not extend beyond 11 mm (0.43 in.) from the top of the magnet, unless it is made of non-ferrous material. The magnet should be installed in a perpendicular orientation relative to the top surface of the sensor extrusion. Optimal performance is achieved when this orientation remains consistent throughout the full measurement stroke range.

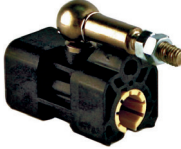
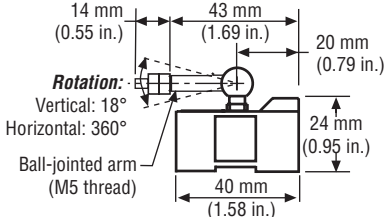
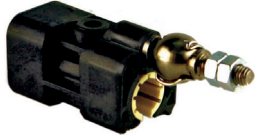
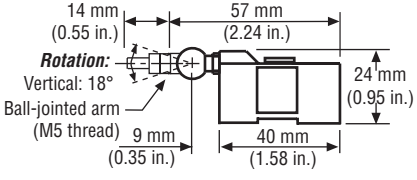
**POSITION MAGNET SELECTIONS (All magnets must be ordered separately)**

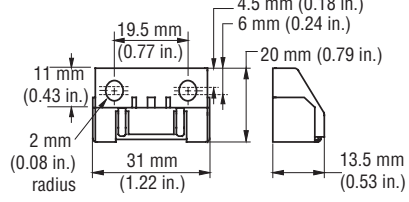
(Drawing dimensions are for reference only)

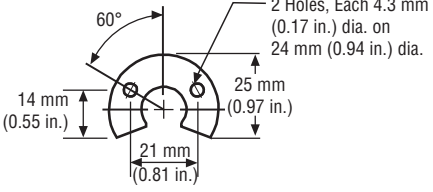
Magnet / accessory dimensions	Description	Part number
 	<p><b>Captive-sliding magnet, Style S</b>            For Sensor models EP and EL profile-style sensors  <b>Material:</b>            GFK, magnet hard ferrite  <b>Weight:</b> Approx. 30 g  <b>Operating temperature:</b>            -40 °C to +75 °C</p>	252182
 	<p><b>Captive-sliding magnet, Style V</b>            For sensor models EP and EL profile-style sensors  <b>Material:</b>            GFK, magnet hard ferrite  <b>Weight:</b> Approx. 30 g  <b>Operating temperature:</b>            -40 °C to +75 °C</p>	252184
 	<p><b>Block magnet, Style L</b>            For sensor models EP and EL profile-style sensors</p> <p>This magnet may influence the sensor performance specifications for some applications.</p>	252887
 	<p><b>Open-ring magnet, Style M</b>  <b>I.D.:</b> 13.5 mm (0.53 in.)  <b>O.D.:</b> 33 mm (1.3 in.)  <b>Thickness:</b> 8 mm (0.31 in.)  <b>Operating temperature:</b>            -40 °C to 100 °C</p> <p>This magnet may influence the sensor performance specifications for some applications.</p>	251416-2

## Sensor mounting (Models EP and EL)

### SENSOR MOUNTING CLAMPS

E-Series models EP and EL sensors are mounted onto the machine with moveable mounting clamps. Mounting clamps slide into side grooves and should be evenly distributed along the sensor extrusion to best secure the sensor for each particular application.

#### Notes:

- Models EP and EL sensors include two mounting clamps, (part number 403508), for stroke lengths up to 1250 mm (50 in.). One additional mounting clamp is included for longer stroke lengths.
- MTS recommends using 10-32 cap screws (customer supplied) at a maximum torque of 44 in. lbs. when fastening mounting clamps.

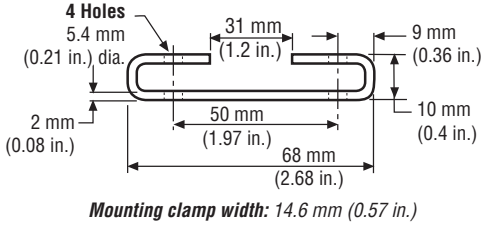
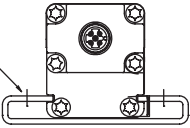
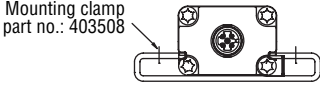
Models EP and EL sensor mounting and installation reference	Mounting method	Part number
 	<p><b>Mounting clamp</b> Sensor mounting for sensor models EP and EL</p>	403508
<p><i>Model EP mounting</i></p> 	<p><i>Model EL mounting</i></p> 	<p><b>Mounting configuration using mounting clamp and screws</b></p> <p><i>Mounting clamp, part number 403508</i></p>

## Connections and wiring (Model EP and EL)

### SENSOR INTEGRAL CONNECTOR (D34 AND D84) PINOUT/WIRE COLOR CODES

The E-Series models EP and EL sensors connect directly to a controller or interface module with the standard male, 5-pin or 8-pin integral connector and an extension cable as described in 'Table 1' and 'Table 2'.

#### Attention:

The sensors aluminum housing has an anodic coating which prevents the sensor's mounting clamps from providing the appropriate grounding. A grounding lug (see 'Figure 7') is provided near the connector end of the sensor for a convenient connection to earth ground. The appropriate grounding of the cable shield is also required at the controller end.

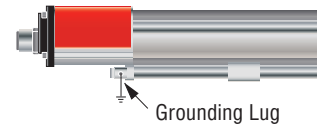

Figure 7. Grounding lug location.



Integral D34 connector (male) as viewed from the end of the sensor

Pin no.	Extension cable wire color	Signal/function analog outputs
1	Brown	+24 Vdc
2	White	Output signal
3	Blue	DC ground (for power return)
4	Black	2nd Output signal (optional)
5	Gray	Ground for signal return

Table 1. Integral D34 sensor connector (mates with cable connectors 370618 and 370619)



Integral D84 connector (male) as viewed from the end of the sensor

Pin no.	Extension cable wire color	Signal/function Start/Stop outputs
1	White	(+) Start
2	Brown	(-) Start
3	Green	(+) Stop
4	Yellow	(-) Stop
5	Gray	No connection
6	Pink	No connection
7	Blue	+24 Vdc
8	Red	DC ground (for power return)

Table 2. Integral D84 sensor connector (mates with cable connectors 370671 and 370672)

**E-Series Model EP and EL Sensors**  
**Cable Connector Options (D34 and D84)**

**MATING CABLE CONNECTOR OPTIONS FOR (D34) CONNECTOR TYPES** *(Photo and drawing dimensions are for reference only)*

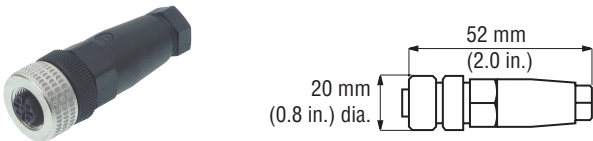
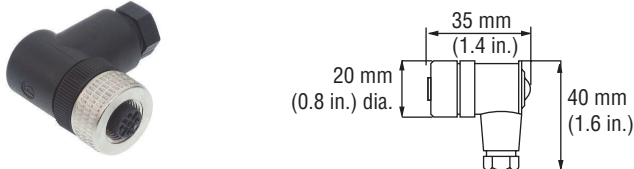
Connector and dimensions	Description	Part number
	<p><b>Female cable connector, straight exit (Field installable)</b>            5-Pin (D34)            Mates with standard male (M12) integral connector  <b>Termination:</b> Screw terminals  <b>Cable gland:</b> PG9 for 6-8 mm dia. cable  <b>Ingress protection:</b> IP67</p>	370618
	<p><b>Female cable connector, 90° exit (Field installable)</b>            5-Pin (D34)            Mates with standard male (M12) integral connector  <b>Termination:</b> Screw terminals  <b>Cable gland:</b> PG9 for 6-8 mm dia. cable  <b>Ingress protection:</b> IP67</p>	370619

**MATING CABLE CONNECTOR OPTIONS FOR (D84) CONNECTOR TYPES** *(Photo and drawing dimensions are for reference only)*

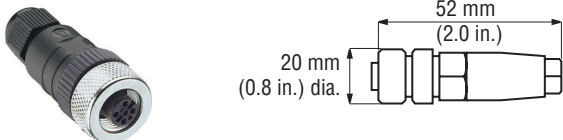
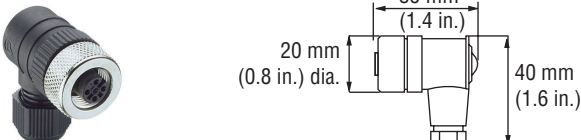
Connector and dimensions	Description	Part number
	<p><b>Female cable connector, straight exit (Field installable)</b>            8-Pin (D84)            Mates with standard male (M12) integral connector  <b>Termination:</b> Screw terminals  <b>Cable gland:</b> PG9 for 6-8 mm dia. cable  <b>Ingress protection:</b> IP67</p>	370671
	<p><b>Female cable connector, 90° exit (Field installable)</b>            8-Pin (D84)            Mates with standard male (M12) integral connector  <b>Termination:</b> Screw terminals  <b>Cable gland:</b> PG9 for 6-8 mm dia. cable  <b>Ingress protection:</b> IP67</p>	370672



**E-Series Model EP and EL Sensors  
(M12) Cord Sets and (M16) Adapter Cable Options**

**M12 CORD SETS AND (M16) ADAPTER CABLE OPTIONS** (Photo and drawing dimensions are for reference only)

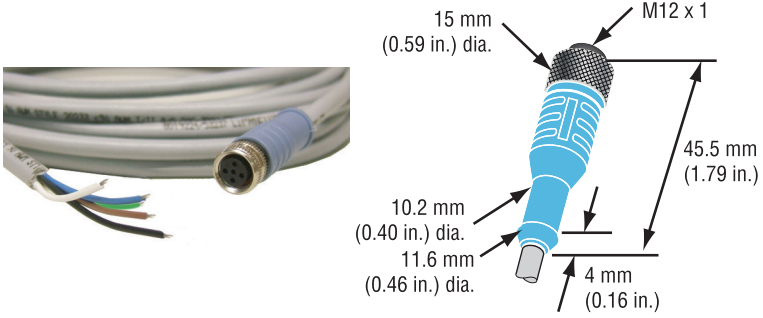
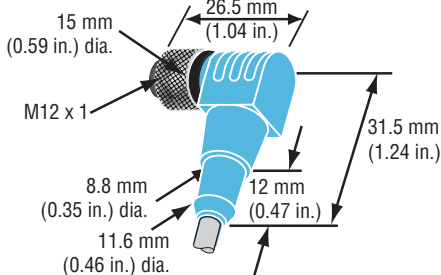
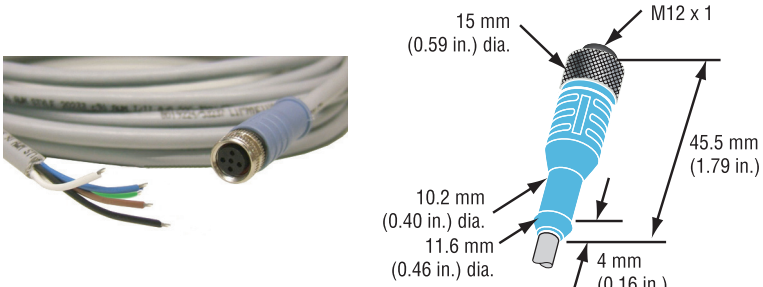
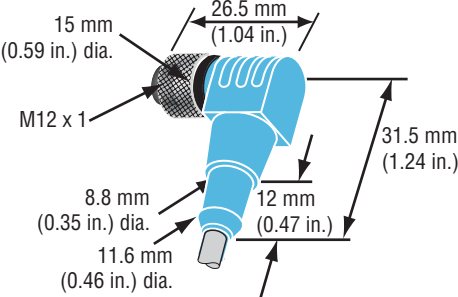
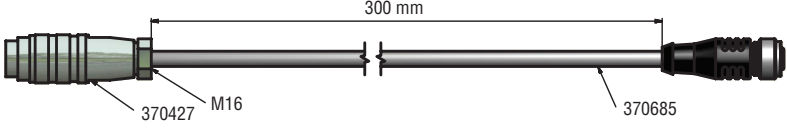
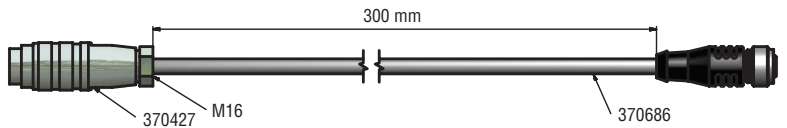
Cord set and dimensions	Description	Part number
	<p><b>M12 Cord set, female connector, Straight exit</b> 5-Pin (M12) mates with standard male (D34) integral connector <b>Ingress protection: IP67</b> <b>Cable: 5 m, shielded, pigtail end</b></p>	370673
<p>(Image not available)</p> 	<p><b>M12 Cord set, female connector 90° exit</b> 5-Pin (M12) mates with standard male (D34) integral connector <b>Ingress protection: IP67</b> <b>Cable: 5 m, shielded, pigtail end</b></p>	370675
	<p><b>M12 Cord set, female connector, straight exit</b> 8-Pin (M12) mates with standard male (D84) integral connector <b>Ingress protection: IP67</b> <b>Cable: 5 m, shielded, pigtail end</b></p>	370674
<p>(Image not available)</p> 	<p><b>M12 Cord set, Female, Connector 90° Exit</b> 8-Pin (M12) mates with standard male (D84) integral connector <b>Ingress protection: IP67</b> <b>Cable: 5 m, shielded, pigtail end</b></p>	370676
Adapter cable and dimensions	Description	Part number
	<p><b>Adapter cable</b> 5-Pin female (M12) connector, straight exit to 6-pin male D60 (M16) connector, straight exit <b>Ingress protection: IP67</b></p>	254257
	<p><b>Adapter cable</b> 8-Pin female (M12) connector, straight exit to 6-pin male D60 (M16) connector, straight exit <b>Ingress protection: IP67</b></p>	254258

## E-Series Models EP and EL Sensors, Analog and Start/Stop Outputs

### Ordering Information

Use the order matrix below to configure your Model EP or EL sensor order number.

E		0							D		1			
1	2	3	4	5	6	7	8	9	10	11	12	13	14	15

**SENSOR MODEL** \_\_\_\_\_ = E  **1 - 2**

**EP** = E-Series model EP profile-style sensor (Magnet(s) must be ordered separately)

**EL** = E-Series model EL low-height profile-style sensor (Magnet(s) must be ordered separately)

**HOUSING STYLE** \_\_\_\_\_ = 0 **3**

**0** = (Zero) EP and EL sensors do not have housing options or magnet types included in the standard model number. Magnets must be purchased separately by part number. Refer to 'Standard magnet selections (Models EP and EL)' in this document for part numbers.

**STROKE LENGTH** \_\_\_\_\_ =           **4 - 8**

----- **M** = Millimeters (Encode in 25, 50, or 100 mm increments as indicated in 'Stroke length notes' below).

----- **.0 U** = Inches (Encode in 1, 2, or 4 in. increments as indicated in 'Stroke length notes' below).

(Digit for tenths of inches is always '0').

#### Stroke Length Notes:

##### Stroke length ranges:

**M** = 50 mm to 2500 mm (up to 3000 mm for model EP Start/Stop only)

**U** = 2 in. to 100 in. (up to 120 in. for model EP Start/Stop only)

##### The increment size between standard stroke lengths vary as shown below:

Stroke length (mm)	Ordering increment
≤ 500 mm	25 mm
> 500 mm and ≤ 2500 mm	50 mm
> 2500 mm and ≤ 3000 mm (For Model EP Start/Stop only)	100 mm
Stroke length (IN)	Ordering increment
≤ 20 in.	1 in.
> 20 in. and ≤ 100 in.	2 in.
> 100 in. and ≤ 120 in. (For Model EP Start/Stop only)	4 in.

**SENSOR CONNECTION TYPES** \_\_\_\_\_ = D   **9 - 11**

**D34** = 5-Pin (M12), male, (Analog output)

**D84** = 8-Pin (M12), male, (Start/Stop output)

**INPUT VOLTAGE** \_\_\_\_\_ = 1 **12**

**1** = + 24 Vdc (+20%, -15%), standard

**OUTPUT** \_\_\_\_\_ =       **13 - 15**

(2 or 3 digit code defined by output option selected).

#### VOLTAGE

**V01** = 0 to 10 Vdc (1 output channel with 1 magnet)

**V11** = 10 to 0 Vdc (1 output channel with 1 magnet)

**V02** = 0 to 10 Vdc (2 output channels with 2 magnets) Refer to 'Dual magnet outputs' for more information.

**V12** = 10 to 0 Vdc (2 output channels with 2 magnets) Refer to 'Dual magnet outputs' for more information.

**V03** = 0 to 10 Vdc and 10 to 0 Vdc (2 output channels with 1 magnet)

#### CURRENT

**A01** = 4 to 20 mA (1 output channel with 1 magnet)

**A11** = 20 to 4 mA (1 output channel with 1 magnet)

**A02** = 4 to 20 mA (2 output channels with 2 magnets) Refer to 'Dual magnet outputs' for more information.

**A12** = 20 to 4 mA (2 output channels with 2 magnets) Refer to 'Dual magnet outputs' for more information.

#### START/STOP

**R3** = Start/Stop with sensor parameters upload function

Start/Stop output (Option **R3**) is fully compatible with the Start/Stop output (Option **R0**) used in the previous generation E-Series sensors.



**Document Part number:**  
551248 Revision A (EN) 05/2014



## LOCATIONS

**USA**  
**MTS Systems Corporation**  
**Sensors Division**  
3001 Sheldon Drive  
Cary, N.C. 27513, USA  
Tel. +1 919 677-0100  
Fax +1 919 677-0200  
info.us@mtssensors.com  
www.mtssensors.com

**GERMANY**  
**MTS Sensor Technologie**  
**GmbH & Co. KG**  
Auf dem Schüffel 9  
58513 Lüdenscheid, Germany  
Tel. +49 2351 9587-0  
Fax +49 2351 56491  
info.de@mtssensors.com  
www.mtssensor.de

**JAPAN**  
**MTS Sensors Technology Corp.**  
737 Aihara-machi,  
Machida-shi,  
Tokyo 194-0211, Japan  
Tel. +81 42 775-3838  
Fax +81 42 775-5512  
info.jp@mtssensors.com  
www.mtssensor.co.jp

**FRANCE**  
**MTS Systems SAS**  
Zone EUROPARC Bâtiment EXA 16  
16/18, rue Eugène Dupuis  
94046 Creteil, France  
Tel. +33 1 58 4390-28  
Fax +33 1 58 4390-03  
info.fr@mtssensors.com  
www.mtssensor.com

**ITALY**  
**MTS Systems Srl. Sensor Division**  
Via Diaz,4  
25050 Provaglio d'Iseo (BS), Italy  
Tel. +39 030 988 3819  
Fax +39 030 982 3359  
info.it@mtssensors.com  
www.mtssensor.com

**CHINA**  
**MTS Sensors**  
Room 504, Huajing Commercial Center,  
No. 188, North Qinzhou Road  
200233 Shanghai, China  
Tel. +86 21 6485 5800  
Fax +86 21 6495 6329  
info.cn@mtssensors.com  
www.mtssensors.cn

## LEGAL NOTICES

MTS, Temposonics and Level Plus are registered trademarks of MTS Systems Corporation. All other trademarks are the property of their respective owners. Printed in USA. Copyright © 2014 MTS Systems Corporation. All Rights Reserved in all media.

All specifications are subject to change. Contact MTS for specifications and engineering drawings that are critical to your application. Drawings contained in this document are for reference only. Go to <http://www.mtssensors.com> for the latest product information.