

7L SERIES PRESSURE RATED HYDRAULIC CYLINDERS . . . 4

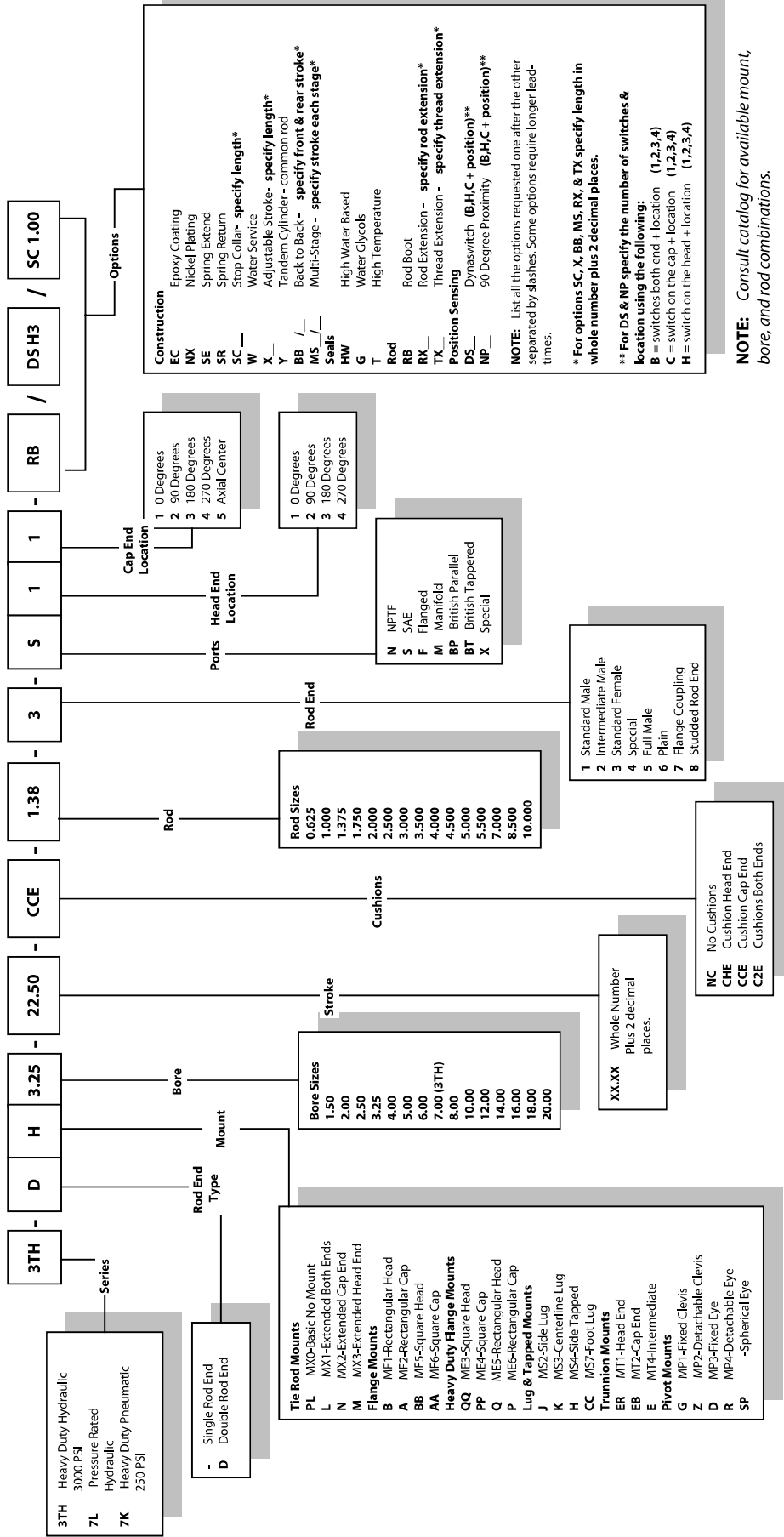

ORDERING INFORMATION



3TH-DH3.25-22.50-CCE-1.38-3-S11-RB/DSH3/SC1.00

For Rod End Dimensions
see back cover foldout...

NOTE: Consult catalog for available mount, bore, and rod combinations.

Series 7L

Basic Cylinder No Mount

1.50" to 6.00"

STYLE O—Basic Plain Mount
(No Mounting)

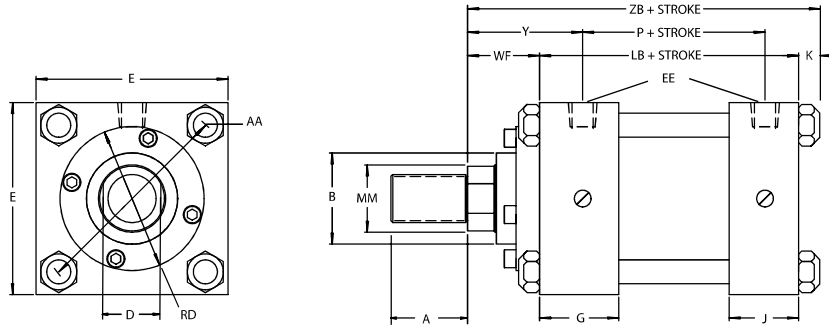

BORE	AA	BB	DD	E	EE		F	G	J	K	R	ADD STROKE		
					NPTF	SAE						LB	LD	P
1½	2.02	1	¼-28	2	⅜	6	⅜	1½	1	¼	1.43	⅜	4⅞	2¼
2	2.6	1⅞	⅝-24	2½	⅜	6	⅜	1½	1	⅝	1.84	⅜	4⅞	2¼
2½	3.1	1⅞	⅝-24	3	⅜	6	⅜	1½	1	⅝	2.19	¾	4¼	2⅝
3¼	3.9	1⅜	⅜-24	3¾	½	10	⅝	1¾	1¼	⅜	2.76	¼	4¾	2⅝
4	4.7	1⅜	⅜-24	4½	½	10	⅝	1¾	1¼	⅜	3.32	¼	4¾	2⅝
5	5.8	1⅜	½-20	5½	½	10	⅝	1¾	1¼	⅜	4.10	½	5	2⅝
6	6.9	1⅜	½-20	6½	¾	12	¾	2	1½	⅜	4.88	5	5½	3⅝

BORE	ROD DIA.		THREAD SIZE		ROD EXTENSIONS AND PILOT DIMENSIONS								ADD STROKE			ADD 2X STK.
	MM	KK	FF	A	+000 -002 B	C	D	NA	FA	RD	VB	WF	Y	ZB	ZT	
1½	⅝	7/16-20	1/2-20	¾	1.124	⅜	½	9/16	⅜	2	⅝	1	1⅝	4⅞	5⅝	6⅞
	1	¾-16	7/8-14	1⅞	1.499	½	7/8	15/16	⅜	—	7/8	1⅜	2⅝	5¼	6	6⅞
2	⅝	7/16-20	1/2-20	¾	1.124	⅜	½	9/16	⅜	2	⅝	1	1⅝	4⅞	5⅝	6⅞
	1⅜	1-14	1¼-12	1⅝	1.999	⅝	1⅞	15/16	⅜	—	1	1⅝	2⅝	5⅞	6⅞	7⅞
2½	1	¾-16	7/8-14	1⅞	1.499	½	7/8	15/16	⅜	2¾	7/8	1⅜	2⅝	5⅞	6¼	7
	1¾	1¼-12	1½-12	2	2.374	¾	1½	11/16	⅜	—	1⅞	1⅞	2⅝	5⅞	6¾	8
3¼	1⅜	1-14	1¼-12	1⅝	1.999	⅝	1⅞	15/16	⅜	—	1	1⅝	2⅝	5⅞	6½	7½
	⅝	7/16-20	1/2-20	¾	1.124	⅜	½	9/16	⅜	2	⅝	1	1⅝	5⅞	5⅞	6¼
4	1	¾-16	7/8-14	1⅞	1.499	½	7/8	15/16	⅜	2¾	7/8	1⅜	2⅝	6	7	7½
	2	1½-12	1¾-12	2¼	2.624	7/8	11/16	15/16	⅝	—	1⅞	2	3⅞	6⅞	7⅞	8¾
5	1¾	1¼-12	1½-12	2	2.374	¾	1½	11/16	⅝	3¾	1⅞	1⅞	2⅝	6½	7½	8¾
	3½	2½-12	3¼-12	3½	4.249	1	3	3⅞	⅝	5½	1¼	2¼	3⅞	7⅞	8⅞	9½
6	2	1½-12	1¾-12	2¼	2.624	7/8	11/16	15/16	⅝	4⅞	1⅞	2	3⅞	6⅞	7⅞	8¾
	2½	1⅞-12	2¼-12	3	3.124	1	2⅞	2⅞	⅝	4½	1¼	2¼	3⅞	7⅞	8⅞	9½
7	3	2¼-12	2¾-12	3½	3.749	1	2⅞	2⅞	⅝	5¼	1¼	2¼	3⅞	7⅞	8⅞	9½
	1	¾-16	7/8-14	1⅞	1.499	½	7/8	15/16	⅜	2¾	7/8	1⅜	2⅝	6⅞	7⅞	7¾
8	1⅜	1-14	1¼-12	1⅝	1.999	⅝	1⅞	15/16	⅜	3¼	1	1⅝	2⅝	6⅞	7⅞	8¼
	1¾	1¼-12	1½-12	2	2.374	¾	1½	11/16	⅝	3¾	1⅞	1⅞	2⅝	6⅞	7⅞	8¼
9	4	3-12	3¾-12	4	4.749	1	3⅞	3⅞	⅝	6	1¼	2¼	3⅞	7⅞	9⅞	10
	2	1½-12	1¾-12	2¼	2.624	7/8	11/16	15/16	⅝	4⅞	1⅞	2	3⅞	7⅞	8⅞	9½
10	2½	1⅞-12	2¼-12	3	3.124	1	2⅞	2⅞	⅝	4½	1¼	2¼	3⅞	7⅞	9⅞	10
	3	2¼-12	2¾-12	3½	3.749	1	2⅞	2⅞	⅝	5¼	1¼	2¼	3⅞	7⅞	9⅞	10
11	3½	2½-12	3¼-12	3½	4.249	1	3	3⅞	⅝	5½	1¼	2¼	3⅞	7⅞	9⅞	10
	1⅜	1-14	1¼-12	1⅝	1.999	⅝	1⅞	15/16	⅜	3¼	1	1⅝	2⅝	7⅞	8⅞	8¾

Series 7L Tie Rod Mounted Cylinders 1.50" to 6.00"

**STYLE L—Tie Rods
Extended Both Ends**
(NFPA Mounting
Style MX1)

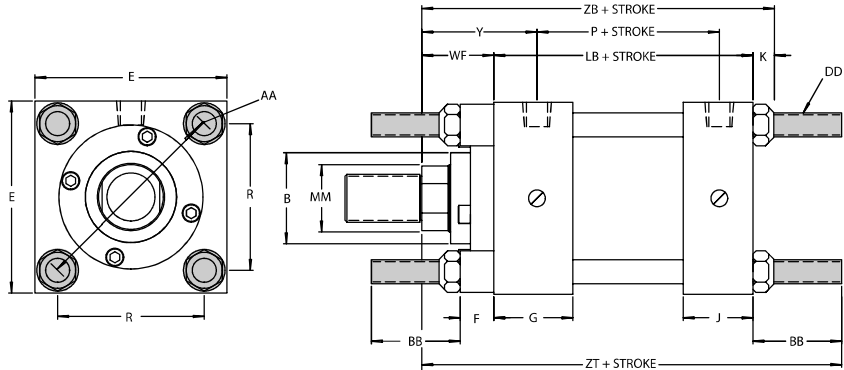

**STYLE DL—Tie Rods
Extended Both Ends
Double Rod End Cylinder**
(NFPA Mounting
Style MDX1)

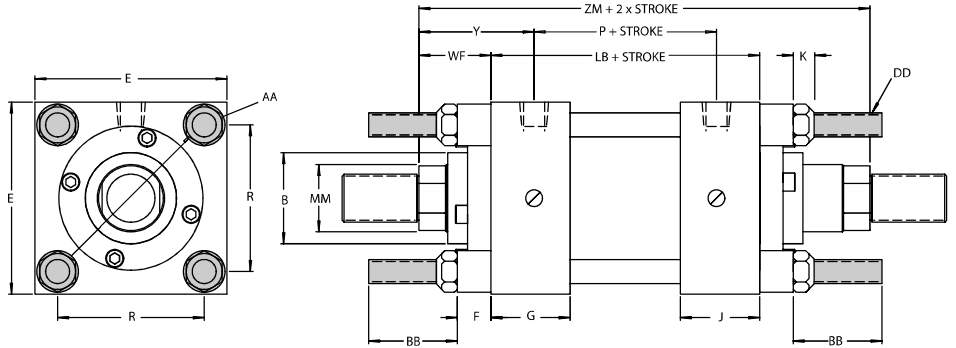

**STYLE M—Tie Rods
Extended Head End**
(NFPA Mounting
Style MX3)

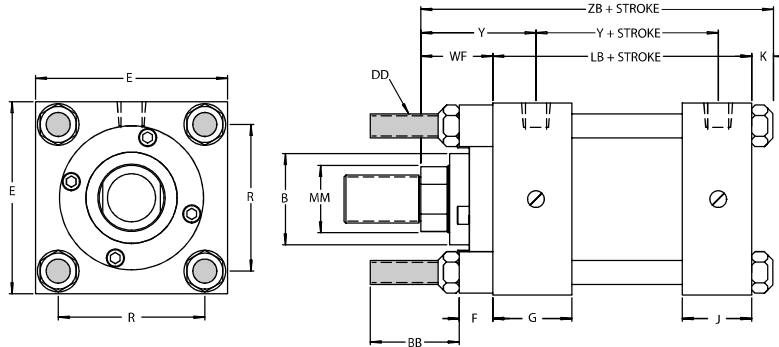

**STYLE N—Tie Rods
Extended Cap End**
(NFPA Mounting
Style MX2)

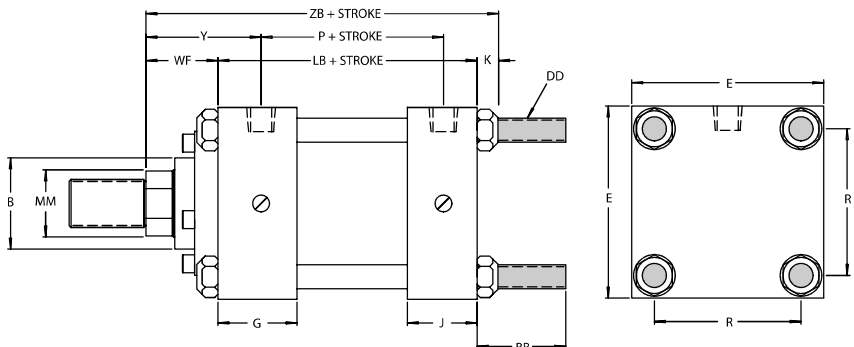

Double rod cylinders are available in all styles except A, AA, EB, and G. Dimensions for other styles are the same as above with mounting added. Add prefix D to style when ordering. Example: DB HYD. CYL.

BB is standard tie rod extension on Styles L, M, N, DL and DM, but will be increased or decreased when specified. To do this, specify BB to be (so many) inches. Extra nuts are available for tie rod ends.

Consult factory on availability of Style DCC cylinder.

ENVELOPE AND MOUNTING DIMENSIONS

BORE	AA	BB	DD	E	EE NPTF	F	G	J	K	R	ADD STROKE		
											LB	LD	P
1½	2.02	1	¼-28	2	⅜	⅜	1½	1	¼	1.43	⅜	4⅛	2¼
2	2.6	1⅛	⅝-24	2½	⅜	⅜	1½	1	⅝	1.84	⅜	4⅛	2¼
2½	3.1	1⅛	⅝-24	3	⅜	⅜	1½	1	⅝	2.19	¾	4¼	2⅜
3¼	3.9	1⅜	⅜-24	3¾	½	⅝	1¾	1¼	⅜	2.76	¾	4¾	2⅝
4	4.7	1⅜	⅜-24	4½	½	⅝	1¾	1¼	⅜	3.32	¾	4¾	2⅝
5	5.8	1⅜	½-20	5½	½	⅝	1¾	1¼	⅞	4.10	½	5	2⅞
6	6.9	1⅜	½-20	6½	¾	¾	2	1½	⅞	4.88	5	5½	3⅞

SAE straight thread ports are optional on all cylinders except the 1½", 2" and 2½" bore sizes with maximum size rods. On these three sizes the head end NPTF ports are tapped shallow. Head end cushions are not available on cylinder bores 1½", 2", and 2½" with maximum size rods.

ROD END DIMENSIONS

ENVELOPE AND MOUNTING DIMENSIONS

BORE	ROD DIA.		THREAD SIZE		ROD EXTENSIONS AND PILOT DIMENSIONS								ADD STROKE		ADD 2X STK.	
	MM	KK	FF	A	+000 -002 B	C	D	NA	FA	RD	VB	WF	Y	ZB	ZT	ZM
1½	⅝	⅞-20	½-20	¾	1.124	⅜	½	⅑	⅜	2	⅝	1	1⅝	4⅞	5⅝	6⅞
	1	¾-16	⅞-14	1⅛	1.499	½	⅞	⅒	⅜	—	⅞	1⅜	2⅝	5¼	6	6⅞
2	⅝	⅞-20	½-20	¾	1.124	⅜	½	⅑	⅜	2	⅝	1	1⅝	4⅞	5⅝	6⅞
	1⅜	1-14	1¼-12	1⅝	1.999	⅝	1⅛	1⅝	⅜	—	1	1⅝	2⅞	5⅞	6⅞	7⅝
2½	⅝	⅞-20	½-20	¾	1.124	⅜	½	⅑	⅜	2	⅝	1	1⅝	5⅞	5⅝	6¼
	1⅜	1¼-12	1½-12	2	2.374	¾	1½	1⅒	⅜	—	1⅛	1⅞	2⅓	5⅞	6¾	8
3¼	1	¾-16	⅞-14	1⅛	1.499	½	⅞	⅒	⅜	2¾	⅞	1⅜	2⅞	6	7	7½
	2	1½-12	1¾-12	2¼	2.624	⅞	1⅒	1⅒	⅝	—	1⅛	2	3⅞	6⅞	7⅝	8¾
	1⅜	1-14	1¼-12	1⅝	1.999	⅝	1⅛	1⅝	⅝	3¼	1	1⅝	2⅒	6¼	7¼	8
	1¾	1¼-12	1½-12	2	2.374	¾	1½	1⅒	⅝	3¾	1⅛	1⅞	2⅓	6½	7½	8½
4	1	¾-16	⅞-14	1⅛	1.499	½	⅞	⅒	⅜	2¾	⅞	1⅜	2⅞	6	7	7½
	2½	1⅞-12	2¼-12	3	3.124	1	2⅞	2⅞	⅝	4½	1¼	2¼	3⅞	6⅞	7⅞	9¼
	1⅜	1-14	1¼-12	1⅝	1.999	⅝	1⅛	1⅝	⅝	3¼	1	1⅝	2⅒	6¼	7¼	8
	1¾	1¼-12	1½-12	2	2.374	¾	1½	1⅒	⅝	3¾	1⅛	1⅞	2⅓	6½	7½	8½
5	2	1½-12	1¾-12	2¼	2.624	⅞	1⅒	1⅒	⅝	4⅞	1⅛	2	3⅞	6⅞	8⅞	9
	2½	1⅞-12	2¼-12	3	3.124	1	2⅞	2⅞	⅝	4½	1¼	2¼	3⅞	7⅞	8⅞	9½
	3	2¼-12	2¾-12	3½	3.749	1	2⅞	2⅞	⅝	5¼	1¼	2¼	3⅞	7⅞	8⅞	9½
	1⅜	1-14	1¼-12	1⅝	1.999	⅝	1⅛	1⅝	⅝	3¼	1	1⅝	2⅒	6⅞	7⅞	8¼
	1¾	1¼-12	1½-12	2	2.374	¾	1½	1⅒	⅝	3¾	1⅛	1⅞	2⅓	6⅞	8⅞	8¾
	2	1½-12	1¾-12	2¼	2.624	⅞	1⅒	1⅒	⅝	4⅞	1⅛	2	3⅞	6⅞	8⅞	9
6	2½	1⅞-12	2¼-12	3	3.124	1	2⅞	2⅞	⅝	4½	1¼	2¼	3⅞	7⅞	8⅞	9½
	3	2¼-12	2¾-12	3½	3.749	1	2⅞	2⅞	⅝	5¼	1¼	2¼	3⅞	7⅞	8⅞	9½
	1⅜	1-14	1¼-12	1⅝	1.999	⅝	1⅛	1⅝	⅝	3¼	1	1⅝	2⅒	6⅞	8⅞	8¾
	4	3-12	3¾-12	4	4.749	1	3⅞	3⅞	¾	6	1¼	2¼	3⅞	7⅞	9⅞	10
	1¾	1¼-12	1½-12	2	2.374	¾	1½	1⅒	⅝	3¾	1⅛	1⅞	2⅓	6⅞	8⅞	9¼
	2	1½-12	1¾-12	2¼	2.624	⅞	1⅒	1⅒	⅝	4⅞	1⅛	2	3⅞	7⅞	8⅞	9½

Series 7L

Foot Mounted Cylinders

1.50" to 6.00"

STYLE J—Side Lug Mount (NFPA Mounting Style MS2)

Do not specify ports in #2 or #4 position without checking clearance between pipe fitting and mounting bolt head. 1/2"-4" bore will require C-Bored mount holes to provide pipe clearance.

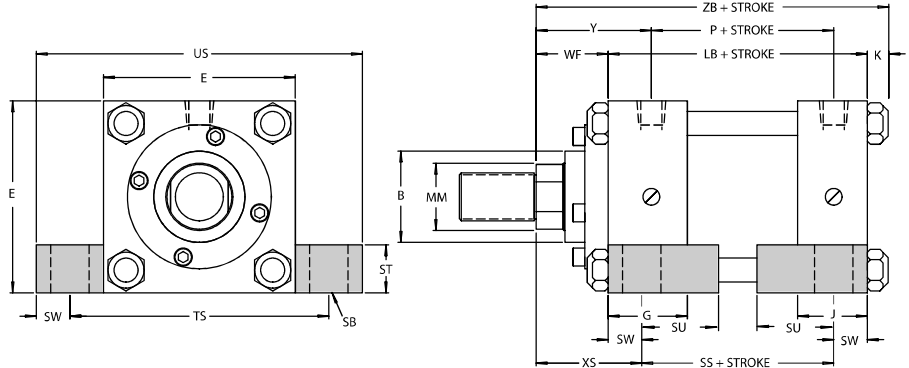

STYLE K—Center Line Mount (NFPA Mounting Style MS3)

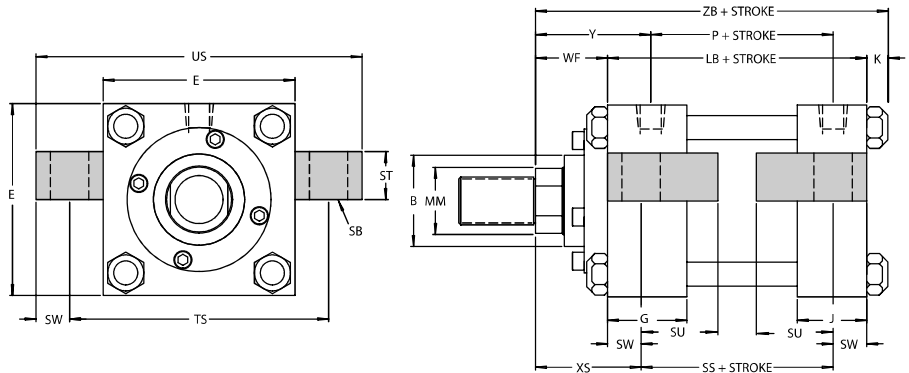

STYLE CC—Foot Mount (NFPA Mounting Style MS7)

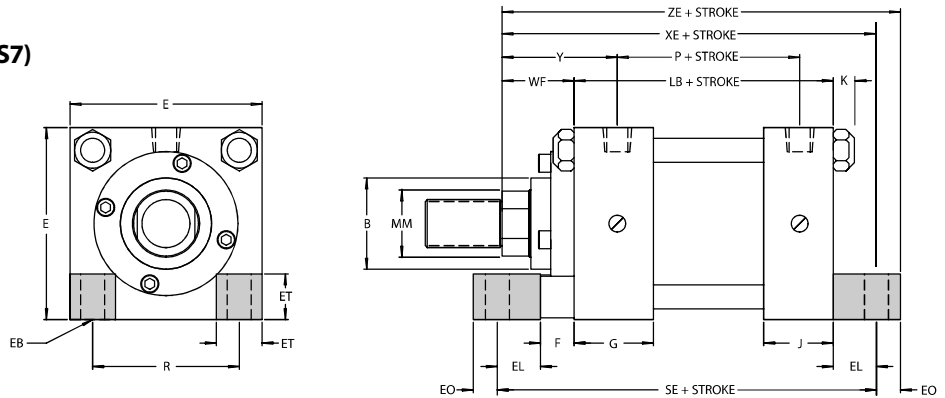

STYLE H—Side Flush Mount (NFPA Mounting Style MS4)

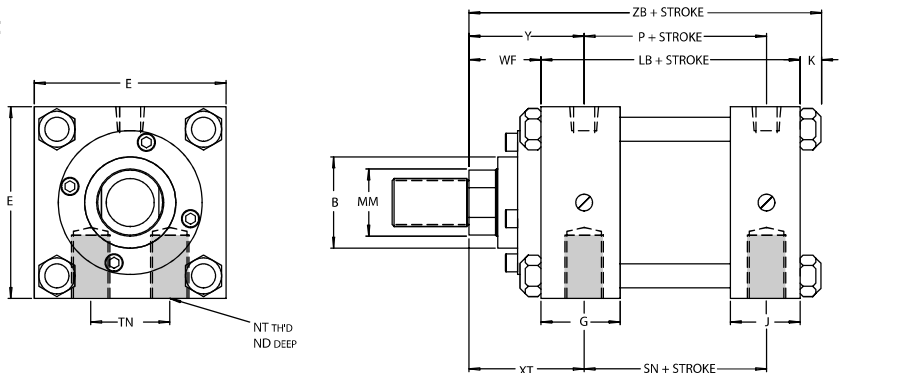

ENVELOPE AND MOUNTING DIMENSIONS

BORE	E	EB*	EE NPTF	EL	EO	ET	F	G	J	K	NT	R	SB*	ST	SU	SW	TN	TS	US	ADD STROKE				
																				LB	P	SE	SN	SS
1 1/2	2	1/4	3/8	3/4	1/4	9/16	3/8	1 1/2	1	1/4	1/4-20	1.43	3/8	1/2	15/16	3/8	5/8	2 3/4	3 1/2	3 5/8	2 1/4	5 1/2	2 1/4	2 7/8
2	2 1/2	5/16	3/8	15/16	5/16	11/16	3/8	1 1/2	1	5/16	5/16-18	1.84	3/8	1/2	15/16	3/8	7/8	3 1/4	4	3 5/8	2 1/4	5 7/8	2 1/4	2 7/8
2 1/2	3	5/16	3/8	1 1/16	5/16	13/16	3/8	1 1/2	1	5/16	3/8-16	2.19	3/8	1/2	15/16	3/8	1 1/4	3 3/4	4 1/2	3 3/4	2 3/8	6 1/4	2 3/8	3
3 1/4	3 3/4	3/8	1/2	7/8	3/8	1	5/8	1 3/4	1 1/4	3/8	1/2-13	2.76	1/2	3/4	1 1/4	1/2	1 1/2	4 3/4	5 3/4	4 1/4	2 5/8	6 5/8	2 5/8	3 1/4
4	4 1/2	3/8	1/2	1	3/8	1 3/16	5/8	1 3/4	1 1/4	3/8	1/2-13	3.32	1/2	3/4	1 1/4	1/2	2 1/16	5 1/2	6 1/2	4 1/4	2 5/8	6 7/8	2 5/8	3 1/4
5	5 1/2	1/2	1/2	1 1/16	1/2	1 3/8	5/8	1 3/4	1 1/4	7/16	5/8-11	4.10	3/4	1	1 9/16	11/16	2 11/16	6 7/8	8 1/4	4 1/2	2 7/8	7 1/4	2 7/8	3 1/8
6	6 1/2	1/2	3/4	1	1/2	1 5/8	3/4	2	1 1/2	7/16	3/4-10	4.88	3/4	1	1 9/16	11/16	3 1/4	7 7/8	9 1/4	5	3 1/8	7 3/4	3 1/8	3 5/8

SAE straight thread ports are optional on all cylinders except the 1 1/2", 2" and 2 1/2" bore sizes with maximum size rods. On these three sizes the head end NPTF ports are tapped shallow. Head end cushions are not available on cylinder bores 1 1/2", 2", and 2 1/2" with maximum size rods.

Styles J, H, K and CC should be pinned or keyed at one end to prevent shifting.

*Mounting holes are 1/16" larger than screw size shown.

ENVELOPE AND MOUNTING DIMENSIONS

ROD END DIMENSIONS

BORE	ROD DIA. MM	THREAD SIZE			ROD EXTENSIONS AND PILOT DIMENSIONS												ADD STROKE		
		KK	FF	A	+000 -002 B	C	D	NA	FA	RD	VB	WF	Y	ND	XS	XT	XE	ZB	ZE
1 1/2	5/8*	7/16-20	1/2-20	3/4	1.124	3/8	1/2	9/16	3/8	2	5/8	1	1 15/16	3/8	1 3/8	1 15/16	5 3/8	4 7/8	5 5/8
	1*	3/4-16	7/8-14	1 1/8	1.499	1/2	7/8	15/16	3/8	—	7/8	1 3/8	2 5/16	1/4	1 3/4	2 5/16	5 3/4	5 1/4	6
2	5/8	7/16-20	1/2-20	3/4	1.124	3/8	1/2	9/16	3/8	2	5/8	1	1 15/16	1/2	1 3/8	1 15/16	5 9/16	4 15/16	5 7/8
	1 3/8*	1-14	1 1/4-12	1 5/8	1.999	5/8	1 1/8	1 5/16	3/8	—	1	1 5/8	2 9/16	5/16	2	2 9/16	6 3/16	5 9/16	6 1/2
2 1/2	5/8	7/16-20	1/2-20	3/4	1.124	3/8	1/2	9/16	3/8	2	5/8	1	1 15/16	9/16	1 3/8	1 15/16	5 13/16	5 1/16	6 1/8
	1 3/4*	1 1/4-12	1 1/2-12	2	2.374	3/4	1 1/2	1 11/16	3/8	—	1 1/8	1 7/8	2 13/16	3/8	2 1/4	2 13/16	6 11/16	5 15/16	7
3 1/4	1	3/4-16	7/8-14	1 1/8	1.499	1/2	7/8	15/16	3/8	2 3/4	7/8	1 3/8	2 5/16	9/16	1 3/4	2 5/16	6 3/16	5 7/16	6 1/2
	1 3/8*	1-14	1 1/4-12	1 5/8	1.999	5/8	1 1/8	1 5/16	3/8	—	1	1 5/8	2 9/16	9/16	2	2 9/16	6 7/16	5 11/16	6 3/4
4	1	3/4-16	7/8-14	1 1/8	1.499	1/2	7/8	15/16	3/8	2 3/4	7/8	1 3/8	2 7/16	3/4	1 7/8	2 7/16	6 5/8	6	7
	2 1/2*	1 7/8-12	2 1/4-12	3	3.124	1	2 1/16	2 3/8	5/8	4 1/2	1 1/4	2 1/4	3 5/16	5/8	2 3/4	3 5/16	7 1/2	6 7/8	7 7/8
5	1 3/8	1-14	1 1/4-12	1 5/8	1.999	5/8	1 1/8	1 5/16	5/8	3 1/4	1	1 5/8	2 11/16	3/4	2 1/8	2 11/16	6 7/8	6 1/4	7 1/4
	1 3/4*	1 1/4-12	1 1/2-12	2	2.374	3/4	1 1/2	1 11/16	5/8	3 3/4	1 1/8	1 7/8	2 15/16	3/4	2 3/8	2 15/16	7 1/8	6 1/2	7 1/2
6	1	3/4-16	7/8-14	1 1/8	1.499	1/2	7/8	15/16	3/8	2 3/4	7/8	1 3/8	2 7/16	3/4	1 7/8	2 7/16	6 15/16	6 5/16	7 1/16
	3 1/2*	2 1/2-12	3 1/4-12	3 1/2	4.249	1	3	3 3/8	5/8	5 1/2	1 1/4	2 1/4	3 5/16	3/4	2 15/16	3 5/16	7 13/16	7 3/16	8 5/16
7	1 3/8	1-14	1 1/4-12	1 5/8	1.999	5/8	1 1/8	1 5/16	5/8	3 1/4	1	1 5/8	2 13/16	1 1/8	2 5/16	2 13/16	7 5/8	7 1/16	8 1/8
	4*	3-12	3 3/4-12	4	4.749	1	3 3/8	3 7/8	3/4	6	1 1/4	2 1/4	3 7/16	1	2 15/16	3 7/16	8 1/4	7 11/16	8 3/4
8	1 3/4	1 1/4-12	1 1/2-12	2	2.374	3/4	1 1/2	1 11/16	5/8	3 3/4	1 1/8	1 7/8	3 1/16	1 1/8	2 9/16	3 1/16	7 7/8	7 5/16	8 3/8
	2	1 1/2-12	1 3/4-12	2 1/4	2.624	7/8	1 11/16	1 15/16	5/8	4 1/8	1 1/8	2	3 1/16	1 1/8	2 11/16	3 1/16	8	7 1/16	8 1/2
9	2 1/2	1 7/8-12	2 1/4-12	3	3.124	1	2 1/16	2 3/8	5/8	4 1/2	1 1/4	2 1/4	3 7/16	1 1/8	2 15/16	3 7/16	8 1/4	7 11/16	8 3/4
	3*	2 1/4-12	2 3/4-12	3 1/2	3.749	1	2 5/8	2 7/8	5/8	5 1/4	1 1/4	2 1/4	3 7/16	1 1/8	2 15/16	3 7/16	8 1/4	7 11/16	8 3/4
10	3 1/2*	2 1/2-12	3 1/4-12	3 1/2	4.249	1	3	3 3/8	5/8	5 1/2	1 1/4	2 1/4	3 7/16	1 1/8	2 15/16	3 7/16	8 1/4	7 11/16	8 3/4

*Style CC foot lugs interfere with cartridge removal.

Series 7L Pivot Mounted Cylinders 1.50" to 6.00"

**STYLE ER—Trunnion Mount
Head End**
(NFA Mounting Style MT1)

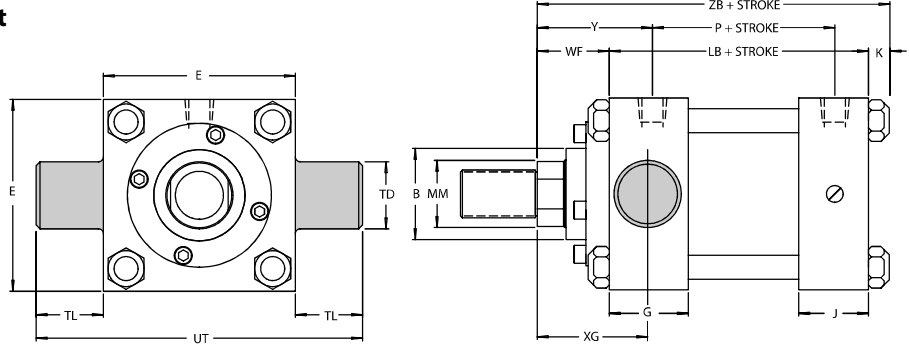

**STYLE EB—Trunnion Mount
Cap End**
(NFA Mounting Style MT2)

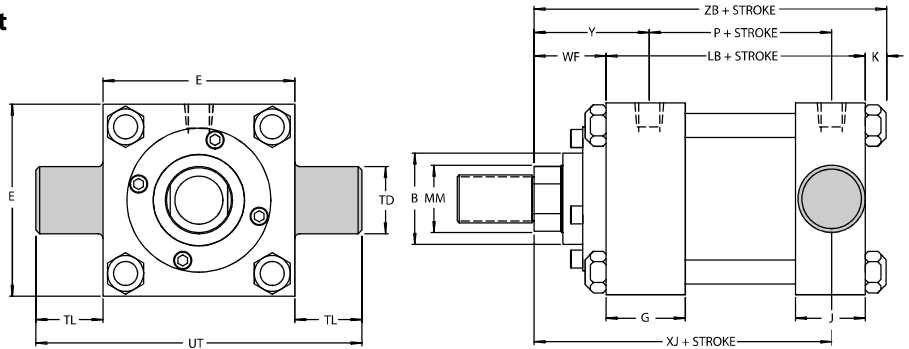

**STYLE E—Intermediate
Trunnion Mount**
(NFA Mounting Style MT4)

Customer to specify Trunnion Location (XI Dim.)

Pintles on trunnion mounted cylinders are designed to withstand shear loads, but not high bending loads. Pillow blocks must be rigidly mounted to provide full support with minimum clearances.

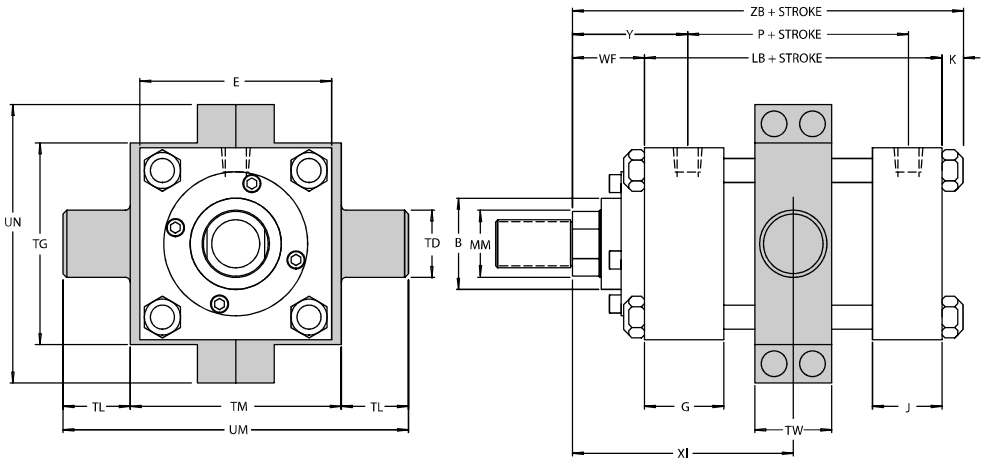

STYLE G—Clevis Mount
(NFA Mounting Style MP1)

Chrome-plated Clevis Pin Assembly (with Snap Rings) is furnished with all Style G Cylinders.

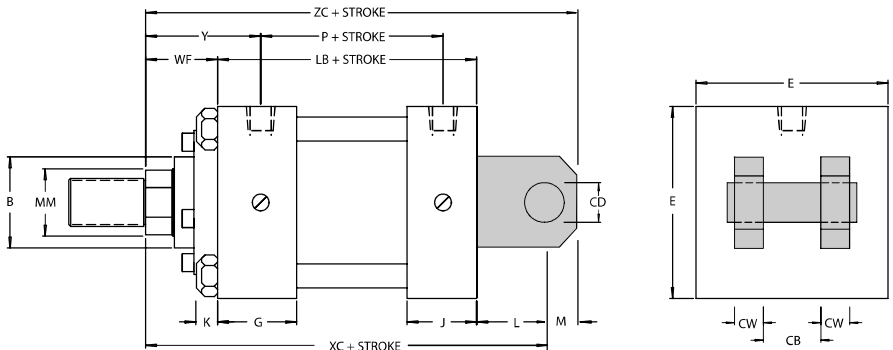

Series 7L
Section 4

ENVELOPE AND MOUNTING DIMENSIONS

BORE	CB	CD	CW	E	EE NPTF	G	J	K	L	LR	M	NR	+000 -001 TD	TL	TG	TM	TW	UM	UT	ADD STROKE	
																				LB	P
1 1/2	3/4	1/2	1/2	2	3/8	1 1/2	1	1/4	3/4	5/8	1/2	9/16	1	1	2 1/2	2 1/2	1 1/4	4 1/2	4	3 5/8	2 1/2
2	3/4	1/2	1/2	2 1/2	3/8	1 1/2	1	5/16	3/4	5/8	1/2	9/16	1	1	3	3	1 1/2	5	4 1/2	3 5/8	2 1/4
2 1/2	3/4	1/2	1/2	3	3/8	1 1/2	1	5/16	3/4	5/8	1/2	9/16	1	1	3 1/2	3 1/2	1 1/2	5 1/2	5	3 3/4	2 3/8
3 1/4	1 1/4	3/4	5/8	3 3/4	1/2	1 3/4	1 1/4	3/8	1 1/4	15/16	3/4	27/32	1	1	4 1/4	4 1/2	2	6 1/2	5 3/4	4 1/4	2 5/8
4	1 1/4	3/4	5/8	4 1/2	1/2	1 3/4	1 1/4	3/8	1 1/4	15/16	3/4	27/32	1	1	5	5 1/4	2	7 1/4	6 1/2	4 1/4	2 5/8
5	1 1/4	3/4	5/8	5 1/2	1/2	1 3/4	1 1/4	7/16	1 1/4	15/16	3/4	27/32	1	1	6	6 1/4	2	8 1/4	7 1/2	4 1/2	2 7/8
6	1 1/2	1	3/4	6 1/2	3/4	2	1 1/2	7/16	1 1/2	1 5/16	1	1 1/8	1 3/8	1 3/8	7	7 5/8	2 1/2	10 3/8	9 1/4	5	3 1/8

SAE straight thread ports are optional on all cylinders except the 1 1/2", 2" and 2 1/2" bore sizes with maximum size rods. On these three sizes the head end NPTF ports are tapped shallow. Head end cushions are not available on cylinder bores 1 1/2", 2", and 2 1/2" with maximum size rods.

ROD END DIMENSIONS

ENVELOPE AND MOUNTING DIMENSIONS

BORE	ROD DIA. MM	THREAD SIZE		ROD EXTENSIONS AND PILOT DIMENSIONS										ADD STROKE					
		KK	FF	A	+000 -002 B	C	D	NA	FA	RD	VB	WF	Y	XG	MIN. XI	XC	XJ	ZB	ZC
1 1/2	5/8	7/16-20	1/2-20	3/4	1.124	3/8	1/2	9/16	3/8	2	5/8	1	1 15/16	1 3/4	3 1/8	5 3/8	4 1/8	4 7/8	5 7/8
	1	3/4-16	7/8-14	1 1/8	1.499	1/2	7/8	15/16	3/8	—	7/8	1 3/8	2 5/16	2 1/8	3 1/2	5 3/4	4 1/2	5 1/4	6 1/4
2	5/8	7/16-20	1/2-20	3/4	1.124	3/8	1/2	9/16	3/8	2	5/8	1	1 15/16	1 3/4	3 1/4	5 3/8	4 1/8	4 15/16	5 7/8
	1 3/8	1-14	1 1/4-12	1 5/8	1.999	5/8	1 1/8	1 5/16	3/8	—	1	1 5/8	2 9/16	2 3/8	3 7/8	6	4 3/4	5 5/16	6 1/2
2 1/2	1	3/4-16	7/8-14	1 1/8	1.499	1/2	7/8	15/16	3/8	—	7/8	1 3/8	2 5/16	2 1/8	3 5/8	5 3/4	4 1/2	5 5/16	6 1/4
	1 3/8	1-14	1 1/4-12	1 5/8	1.999	5/8	1 1/8	1 5/16	3/8	—	1	1 5/8	2 9/16	2 3/8	3 7/8	6 1/8	4 7/8	5 11/16	6 5/8
3 1/4	1	3/4-16	7/8-14	1 1/8	1.499	1/2	7/8	15/16	3/8	2 3/4	7/8	1 3/8	2 7/16	2 1/4	4 1/8	6 7/8	5	6	7 5/8
	2	1 1/2-12	1 3/4-12	2 1/4	2.624	7/8	1 11/16	1 15/16	5/8	—	1 1/8	2	3 1/16	2 7/8	4 3/4	7 1/2	5 5/8	6 5/8	8 1/4
4	1 3/8	1-14	1 1/4-12	1 5/8	1.999	5/8	1 1/8	1 5/16	5/8	3 1/4	1	1 5/8	2 11/16	2 1/2	4 3/8	7 1/8	5 1/4	6 1/4	7 7/8
	1 3/4	1 1/4-12	1 1/2-12	2	2.374	3/4	1 1/2	1 11/16	5/8	3 3/4	1 1/8	1 7/8	2 15/16	2 3/4	4 5/8	7 3/8	5 1/2	6 1/2	8 1/8
5	2	1 1/2-12	1 3/4-12	2 1/4	2.624	7/8	1 11/16	1 15/16	5/8	4 1/8	1 1/8	2	3 1/16	2 7/8	4 3/4	7 3/4	5 7/8	6 15/16	8 1/2
	2 1/2	1 7/8-12	2 1/4-12	3	3.124	1	2 1/16	2 3/8	5/8	4 1/2	1 1/4	2 1/4	3 5/16	3 3/8	5	8	6 1/8	7 3/16	8 3/4
6	3	2 1/4-12	2 3/4-12	3 1/2	3.749	1	2 5/8	2 7/8	5/8	5 1/4	1 1/4	2 1/4	3 5/16	3 3/8	5	8	6 1/8	7 3/16	8 3/4
	1 3/8	1-14	1 1/4-12	1 5/8	1.999	5/8	1 1/8	1 5/16	5/8	3 3/4	1	1 5/8	2 13/16	2 5/8	4 7/8	8 1/8	5 7/8	7 1/16	9 1/8
6	4	3-12	3 3/4-12	4	4.749	1	3 3/8	3 7/8	3/4	6	1 1/4	2 1/4	3 7/16	3 3/4	5 1/2	8 3/4	6 1/2	7 11/16	9 3/4
	1 3/4	1 1/4-12	1 1/2-12	2	2.374	3/4	1 1/2	1 11/16	5/8	3 3/4	1 1/8	1 7/8	3 1/16	2 7/8	5 1/8	8 3/8	6 1/8	7 3/16	9 3/8
6	2	1 1/2-12	1 3/4-12	2 1/4	2.624	7/8	1 11/16	1 15/16	5/8	4 1/8	1 1/8	2	3 3/16	3	5 1/4	8 1/2	6 1/4	7 1/16	9 1/2
	2 1/2	1 7/8-12	2 1/4-12	3	3.124	1	2 1/16	2 3/8	5/8	4 1/2	1 1/4	2 1/4	3 7/16	3 3/4	5 1/2	8 3/4	6 1/2	7 11/16	9 3/4
6	3	2 1/4-12	2 3/4-12	3 1/2	3.749	1	2 5/8	2 7/8	5/8	5 1/4	1 1/4	2 1/4	3 7/16	3 3/4	5 1/2	8 3/4	6 1/2	7 11/16	9 3/4
	3 1/2	2 1/2-12	3 1/4-12	3 1/2	4.249	1	3	3 3/8	5/8	5 1/2	1 1/4	2 1/4	3 7/16	3 3/4	5 1/2	8 3/4	6 1/2	7 11/16	9 3/4

Series 7L Flange Mounted Cylinders 1.50" to 6.00"

**STYLE B—Rectangular Flange
Mount Head End**
(NFPA Mounting Style MF1)

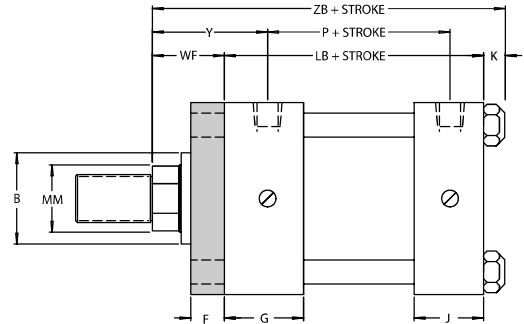
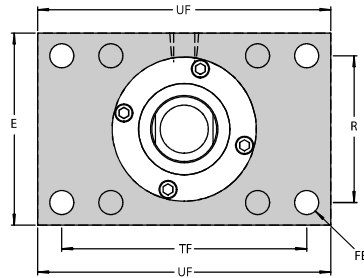

**STYLE A—Rectangular Flange
Mount Cap End**
(NFPA Mounting Style MF2)

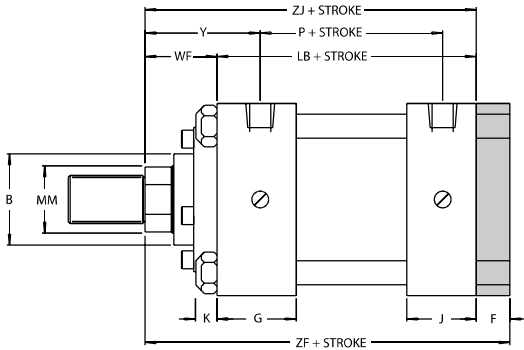
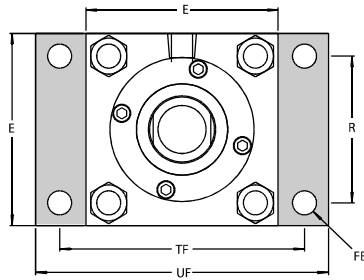

**STYLE BB—Square Flange
Mount Head End**
(NFPA Mounting Style MF5)

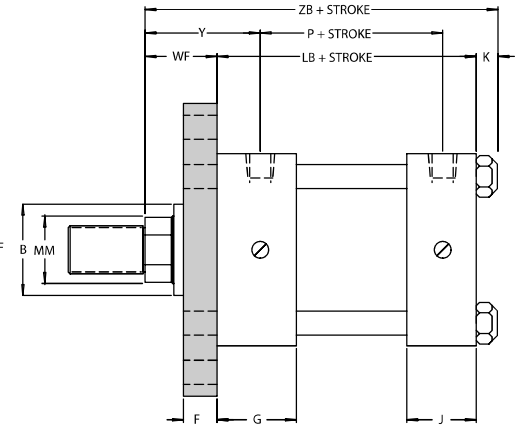
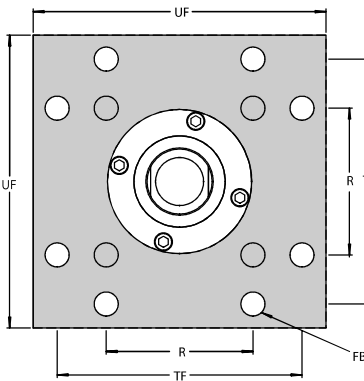

**STYLE AA—Square Flange
Mount Cap End**
(NFPA Mounting Style MF6)

Styles "AA" or "BB" are recommended for maximum pressures and shock loads.

We recommend the use of high tensile mounting bolts on all flange mounted cylinders subject to maximum pressures and shock loads.

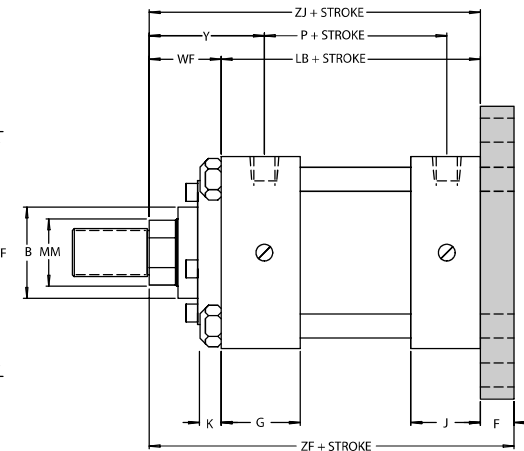
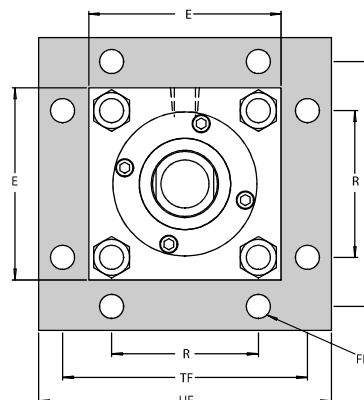

ENVELOPE AND MOUNTING DIMENSIONS

BORE	E	EE NPTF	F	FB*	G	J	K	R	TF	UF	ADD STROKE	
											LF	P
1 1/2	2	3/8	3/8	1/4	1 1/2	1	1/4	1.43	2 3/4	3 3/8	4	2 1/4
2	2 1/2	3/8	3/8	5/16	1 1/2	1	5/16	1.84	3 3/8	4 1/8	4	2 1/4
2 1/2	3	3/8	3/8	5/16	1 1/2	1	5/16	2.19	3 7/8	4 5/8	4 1/8	2 3/8
3 1/4	3 3/4	1/2	5/8	3/8	1 3/4	1 1/4	3/8	2.76	4 11/16	5 1/2	4 7/8	2 5/8
4	4 1/2	1/2	5/8	3/8	1 3/4	1 1/4	3/8	3.32	5 7/16	6 1/4	4 7/8	2 5/8
5	5 1/2	1/2	5/8	1/2	1 3/4	1 1/4	7/16	4.10	6 5/8	7 5/8	5 1/8	2 7/8
6	6 1/2	3/4	3/4	1/2	2	1 1/2	7/16	4.88	7 5/8	8 5/8	5 3/4	3 1/8

SAE straight thread ports are optional on all cylinders except the 1 1/2", 2" and 2 1/2" bore sizes with maximum size rods. On these three sizes the head end NPTF ports are tapped shallow. Head end cushions are not available on cylinder bores 1 1/2", 2", and 2 1/2" with maximum size rods.

*Mounting holes are 1/16" larger than screw size shown.

ROD END DIMENSIONS

ENVELOPE AND MOUNTING DIMENSIONS

BORE	ROD DIA. MM	THREAD SIZE		ROD EXTENSIONS AND PILOT DIMENSIONS								ADD STROKE					
		KK	FF	A	+000 -002 B	C	D	NA	FA	RD	VB	WF	Y	W	ZJ	ZB	ZF
1 1/2	5/8*	7/16-20	1/2-20	3/4	1.124	3/8	1/2	9/16	3/8	2	5/8	1	1 15/16	5/8	4 3/8	4 7/8	5
	1*	3/4-16	7/8-14	1 1/8	1.499	1/2	7/8	15/16	3/8	—	7/8	1 3/8	2 5/16	1	5	5 1/4	5 3/8
2	5/8*	7/16-20	1/2-20	3/4	1.124	3/8	1/2	9/16	3/8	2	5/8	1	1 15/16	5/8	4 3/8	4 15/16	5
	1 3/8*	1-14	1 1/4-12	1 5/8	1.999	5/8	1 1/8	1 5/16	3/8	—	1	1 5/8	2 9/16	1 1/4	5 1/4	5 9/16	5 5/8
2 1/2	5/8*	7/16-20	1/2-20	3/4	1.124	3/8	1/2	9/16	3/8	2	5/8	1	1 15/16	5/8	4 3/4	5 1/16	5 1/8
	1 3/4*	1 1/4-12	1 1/2-12	2	2.374	3/4	1 1/2	1 11/16	3/8	—	1 1/8	1 7/8	2 13/16	1 1/2	5 5/8	5 15/16	6
3 1/4	1*	3/4-16	7/8-14	1 1/8	1.499	1/2	7/8	15/16	3/8	2 3/4	7/8	1 3/8	2 5/16	1	5 1/8	5 1/16	5 1/2
	1 3/8*	1-14	1 1/4-12	1 5/8	1.999	5/8	1 1/8	1 5/16	3/8	—	1	1 5/8	2 9/16	1 1/4	5 3/8	5 11/16	5 3/4
4	1	3/4-16	7/8-14	1 1/8	1.499	1/2	7/8	15/16	3/8	2 3/4	7/8	1 3/8	2 7/16	3/4	5 5/8	6	6 1/4
	2 1/2*	1 7/8-12	2 1/4-12	3	3.124	1	2 1/16	2 3/8	5/8	4 1/2	1 1/4	2 1/4	3 5/16	1 5/8	6 1/2	6 7/8	7 1/8
5	1 3/8*	1-14	1 1/4-12	1 5/8	1.999	5/8	1 1/8	1 5/16	3/8	3 1/4	1	1 5/8	2 11/16	1	5 7/8	6 1/4	6 1/2
	1 3/4*	1 1/4-12	1 1/2-12	2	2.374	3/4	1 1/2	1 11/16	5/8	3 3/4	1 1/8	1 7/8	2 15/16	1 1/4	6 3/8	6 1/2	6 3/4
6	2*	1 1/2-12	1 3/4-12	2 1/4	2.624	7/8	1 11/16	1 15/16	5/8	4 1/8	1 1/8	2	3 1/16	1 3/8	6 1/4	6 3/8	6 7/8
	1	3/4-16	7/8-14	1 1/8	1.499	1/2	7/8	15/16	3/8	2 3/4	7/8	1 3/8	2 7/16	3/4	5 5/8	6 5/16	6 1/2
7	3 1/2*	2 1/2-12	3 1/4-12	3 1/2	4.249	1	3	3 3/8	5/8	5 1/2	1 1/4	2 1/4	3 5/16	1 5/8	6 3/4	7 3/16	7 3/8
	1 3/8	1-14	1 1/4-12	1 5/8	1.999	5/8	1 1/8	1 5/16	3/8	3 1/4	1	1 5/8	2 11/16	1	6 3/8	6 9/16	6 3/4
8	1 3/4	1 1/4-12	1 1/2-12	2	2.374	3/4	1 1/2	1 11/16	5/8	3 3/4	1 1/8	1 7/8	2 15/16	1 1/4	6 3/8	6 13/16	7
	2	1 1/2-12	1 3/4-12	2 1/4	2.624	7/8	1 11/16	1 15/16	5/8	4 1/8	1 1/8	2	3 1/16	1 3/8	6 1/2	6 15/16	7 1/8
9	2 1/2*	1 7/8-12	2 1/4-12	3	3.124	1	2 1/16	2 3/8	5/8	4 1/2	1 1/4	2 1/4	3 5/16	1 5/8	6 3/4	7 3/16	7 3/8
	3*	2 1/4-12	2 3/4-12	3 1/2	3.749	1	2 5/8	2 7/8	5/8	5 1/4	1 1/4	2 1/4	3 5/16	1 5/8	6 3/4	7 3/16	7 3/8
10	1 3/8	1-14	1 1/4-12	1 5/8	1.999	5/8	1 1/8	1 5/16	3/8	3 1/4	1	1 5/8	2 13/16	7/8	6 3/8	7 1/16	7 3/8
	4*	3-12	3 3/4-12	4	4.749	1	3 3/8	3 7/8	3/4	6	1 1/4	2 1/4	3 7/16	1 1/2	7 1/4	7 11/16	8
11	1 3/4	1 1/4-12	1 1/2-12	2	2.374	3/4	1 1/2	1 11/16	5/8	3 3/4	1 1/8	1 7/8	3 1/16	1 1/8	6 3/8	7 3/16	7 5/8
	2	1 1/2-12	1 3/4-12	2 1/4	2.624	7/8	1 11/16	1 15/16	5/8	4 1/8	1 1/8	2	3 3/16	1 1/4	7	7 1/16	7 3/4
12	2 1/2	1 7/8-12	2 1/4-12	3	3.124	1	2 1/16	2 3/8	5/8	4 1/2	1 1/4	2 1/4	3 7/16	1 1/2	7 1/4	7 11/16	8
	3	2 1/4-12	2 3/4-12	3 1/2	3.749	1	2 5/8	2 7/8	5/8	5 1/4	1 1/4	2 1/4	3 7/16	1 1/2	7 1/4	7 11/16	8
13	3 1/2	2 1/2-12	3 1/4-12	3 1/2	4.249	1	3	3 3/8	5/8	5 1/2	1 1/4	2 1/4	3 7/16	1 1/2	7 1/4	7 11/16	8

*These bore and rod combinations use the flange to retain the bearing on "B" and "BB" mounts.

Series 7L

Heavy Duty Flange Mounted Cylinders

1.50" to 6.00"

STYLE Q—Rectangular Head End Mount
(NFPA Mounting Style ME5)

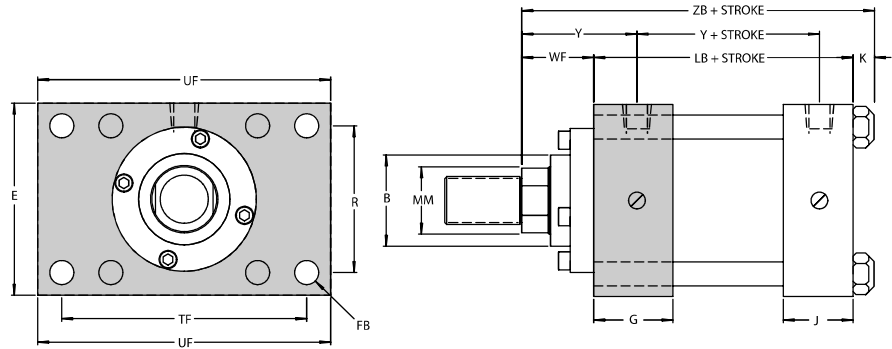

STYLE P—Rectangular Cap End Mount
(NFPA Mounting Style ME6)

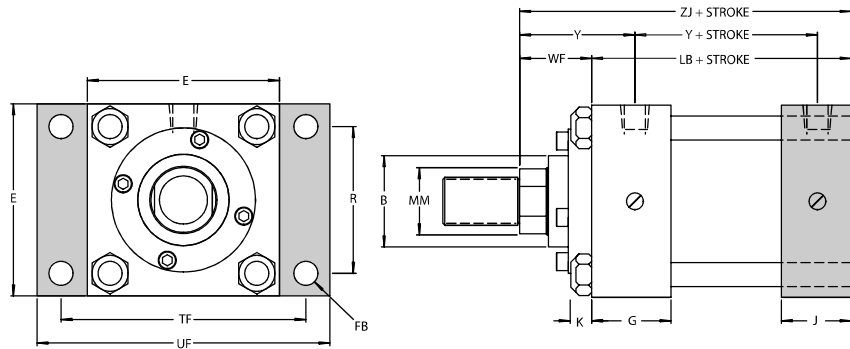

Series 7L
Section 4

BORE	E	EE		FB*	G	J	K	R	TF	UF	ADD STROKE	
		NPTF	SAE								LB	P
1½	2	¾	6	¼	1½	1	¼	1.43	2¾	3⅜	3⅜	2¼
2	2½	¾	6	⅝	1½	1	⅝	1.84	3⅜	4⅞	3⅜	2¼
2½	3	¾	6	⅝	1½	1	⅝	2.19	3⅞	4⅞	3¼	2⅜
3¼	3¾	½	10	¾	1¾	1¼	¾	2.76	4 ¹¹ / ₁₆	5½	4¼	2⅝
4	4½	½	10	¾	1¾	1¼	¾	3.32	5 ⁷ / ₁₆	6¼	4¼	2⅝
5	5½	½	10	½	1¾	1¼	⁷ / ₁₆	4.10	6 ⁵ / ₈	7 ³ / ₈	4½	2⅞
6	6½	¾	12	½	2	1½	⁷ / ₁₆	4.88	7 ⁵ / ₈	8 ⁵ / ₈	5	3⅜

BORE	ROD DIA.	THREAD SIZE			ROD EXTENSIONS AND PILOT DIMENSIONS								ADD STROKE		
	MM	KK	FF	A	+000 -002 B	C	D	NA	FA	RD	VB	WF	Y	ZJ	ZB
1½	⅝	⁷ / ₁₆ -20	½-20	¾	1.124	¾	½	⁹ / ₁₆	¾	2	⅝	1	¹⁵ / ₁₆	4 ⁵ / ₈	4 ⁷ / ₈
	1	¾-16	⁷ / ₈ -14	1⅞	1.499	½	⁷ / ₈	¹⁵ / ₁₆	¾	—	⁷ / ₈	1 ³ / ₈	2 ⁵ / ₁₆	5	5¼
2	⅝	⁷ / ₁₆ -20	½-20	¾	1.124	¾	½	⁹ / ₁₆	¾	2	⅝	1	¹⁵ / ₁₆	4 ⁵ / ₈	4 ¹⁵ / ₁₆
	1⅜	1-14	1¼-12	1⅝	1.999	⅝	1⅞	1 ⁵ / ₁₆	¾	—	1	1 ⁵ / ₈	2 ⁹ / ₁₆	5¼	5 ⁹ / ₁₆
2½	1	¾-16	⁷ / ₈ -14	1⅞	1.499	½	⁷ / ₈	¹⁵ / ₁₆	¾	—	⁷ / ₈	1 ³ / ₈	2 ⁵ / ₁₆	5	5 ⁹ / ₁₆
	1⅜	1-14	1¼-12	1⅝	1.999	⅝	1⅞	1 ⁵ / ₁₆	¾	—	1	1 ⁵ / ₈	2 ⁹ / ₁₆	5¼	5 ⁹ / ₁₆
3¼	1	¾-16	⁷ / ₈ -14	1⅞	1.499	½	⁷ / ₈	¹⁵ / ₁₆	¾	2¾	⁷ / ₈	1 ³ / ₈	2 ⁵ / ₁₆	5⅞	5 ¹⁵ / ₁₆
	1⅜	1-14	1¼-12	1⅝	1.999	⅝	1⅞	1 ⁵ / ₁₆	¾	—	1	1 ⁵ / ₈	2 ⁹ / ₁₆	5⅞	5 ¹⁵ / ₁₆
4	1⅜	1-14	1¼-12	1⅝	1.999	⅝	1⅞	1 ⁵ / ₁₆	¾	—	1	1 ⁵ / ₈	2 ⁹ / ₁₆	5⅞	5 ¹⁵ / ₁₆
	2	1½-12	1¾-12	2	2.374	¾	1½	1 ¹¹ / ₁₆	¾	—	1⅞	1 ⁷ / ₈	2 ¹³ / ₁₆	5⅞	5 ¹⁵ / ₁₆
5	1⅜	1-14	1¼-12	1⅝	1.999	⅝	1⅞	1 ⁵ / ₁₆	¾	—	1	1 ⁵ / ₈	2 ⁹ / ₁₆	5⅞	5 ¹⁵ / ₁₆
	2	1½-12	1¾-12	2	2.374	¾	1½	1 ¹¹ / ₁₆	¾	3¼	1⅞	1 ⁷ / ₈	2 ¹⁵ / ₁₆	6⅞	6½
6	1⅜	1-14	1¼-12	1⅝	1.999	⅝	1⅞	1 ⁵ / ₁₆	¾	2¾	⁷ / ₈	1 ³ / ₈	2 ⁵ / ₁₆	5⅞	6
	2	1½-12	1¾-12	2	2.374	¾	1½	1 ¹¹ / ₁₆	¾	—	1⅞	1 ⁷ / ₈	2 ¹³ / ₁₆	5⅞	5 ¹⁵ / ₁₆
7	1⅜	1-14	1¼-12	1⅝	1.999	⅝	1⅞	1 ⁵ / ₁₆	¾	2¾	⁷ / ₈	1 ³ / ₈	2 ⁵ / ₁₆	5⅞	6
	2	1½-12	1¾-12	2	2.374	¾	1½	1 ¹¹ / ₁₆	¾	—	1⅞	1 ⁷ / ₈	2 ¹³ / ₁₆	5⅞	5 ¹⁵ / ₁₆
8	1⅜	1-14	1¼-12	1⅝	1.999	⅝	1⅞	1 ⁵ / ₁₆	¾	—	1	1 ⁵ / ₈	2 ⁹ / ₁₆	5⅞	6
	2	1½-12	1¾-12	2	2.374	¾	1½	1 ¹¹ / ₁₆	¾	3¼	1⅞	1 ⁷ / ₈	2 ¹⁵ / ₁₆	6⅞	6½
9	1⅜	1-14	1¼-12	1⅝	1.999	⅝	1⅞	1 ⁵ / ₁₆	¾	—	1	1 ⁵ / ₈	2 ⁹ / ₁₆	5⅞	6
	2	1½-12	1¾-12	2	2.374	¾	1½	1 ¹¹ / ₁₆	¾	—	1⅞	1 ⁷ / ₈	2 ¹³ / ₁₆	5⅞	5 ¹⁵ / ₁₆
10	1⅜	1-14	1¼-12	1⅝	1.999	⅝	1⅞	1 ⁵ / ₁₆	¾	—	1	1 ⁵ / ₈	2 ⁹ / ₁₆	5⅞	6
	2	1½-12	1¾-12	2	2.374	¾	1½	1 ¹¹ / ₁₆	¾	—	1⅞	1 ⁷ / ₈	2 ¹³ / ₁₆	5⅞	5 ¹⁵ / ₁₆
11	1⅜	1-14	1¼-12	1⅝	1.999	⅝	1⅞	1 ⁵ / ₁₆	¾	—	1	1 ⁵ / ₈	2 ⁹ / ₁₆	5⅞	6
	2	1½-12	1¾-12	2	2.374	¾	1½	1 ¹¹ / ₁₆	¾	—	1⅞	1 ⁷ / ₈	2 ¹³ / ₁₆	5⅞	5 ¹⁵ / ₁₆
12	1⅜	1-14	1¼-12	1⅝	1.999	⅝	1⅞	1 ⁵ / ₁₆	¾	—	1	1 ⁵ / ₈	2 ⁹ / ₁₆	5⅞	6
	2	1½-12	1¾-12	2	2.374	¾	1½	1 ¹¹ / ₁₆	¾	—	1⅞	1 ⁷ / ₈	2 ¹³ / ₁₆	5⅞	5 ¹⁵ / ₁₆
13	1⅜	1-14	1¼-12	1⅝	1.999	⅝	1⅞	1 ⁵ / ₁₆	¾	—	1	1 ⁵ / ₈	2 ⁹ / ₁₆	5⅞	6
	2	1½-12	1¾-12	2	2.374	¾	1½	1 ¹¹ / ₁₆	¾	—	1⅞	1 ⁷ / ₈	2 ¹³ / ₁₆	5⅞	5 ¹⁵ / ₁₆
14	1⅜	1-14	1¼-12	1⅝	1.999	⅝	1⅞	1 ⁵ / ₁₆	¾	—	1	1 ⁵ / ₈	2 ⁹ / ₁₆	5⅞	6
	2	1½-12	1¾-12	2	2.374	¾	1½	1 ¹¹ / ₁₆	¾	—	1⅞	1 ⁷ / ₈	2 ¹³ / ₁₆	5⅞	5 ¹⁵ / ₁₆
15	1⅜	1-14	1¼-12	1⅝	1.999	⅝	1⅞	1 ⁵ / ₁₆	¾	—	1	1 ⁵ / ₈	2 ⁹ / ₁₆	5⅞	6
	2	1½-12	1¾-12	2	2.374	¾	1½	1 ¹¹ / ₁₆	¾	—	1⅞	1 ⁷ / ₈	2 ¹³ / ₁₆	5⅞	5 ¹⁵ / ₁₆
16	1⅜	1-14	1¼-12	1⅝	1.999	⅝	1⅞	1 ⁵ / ₁₆	¾	—	1	1 ⁵ / ₈	2 ⁹ / ₁₆	5⅞	6
	2	1½-12	1¾-12	2	2.374	¾	1½	1 ¹¹ / ₁₆	¾	—	1⅞	1 ⁷ / ₈	2 ¹³ / ₁₆	5⅞	5 ¹⁵ / ₁₆
17	1⅜	1-14	1¼-12	1⅝	1.999	⅝	1⅞	1 ⁵ / ₁₆	¾	—	1	1 ⁵ / ₈	2 ⁹ / ₁₆	5⅞	6
	2	1½-12	1¾-12	2	2.374	¾	1½	1 ¹¹ / ₁₆	¾	—	1⅞	1 ⁷ / ₈	2 ¹³ / ₁₆	5⅞	5 ¹⁵ / ₁₆
18	1⅜	1-14	1¼-12	1⅝	1.999	⅝	1⅞	1 ⁵ / ₁₆	¾	—	1	1 ⁵ / ₈	2 ⁹ / ₁₆	5⅞	6
	2	1½-12	1¾-12	2	2.374	¾	1½	1 ¹¹ / ₁₆	¾	—	1⅞	1 ⁷ / ₈	2 ¹³ / ₁₆	5⅞	5 ¹⁵ / ₁₆
19	1⅜	1-14	1¼-12	1⅝	1.999	⅝	1⅞	1 ⁵ / ₁₆	¾	—	1	1 ⁵ / ₈	2 ⁹ / ₁₆	5⅞	6
	2	1½-12	1¾-12	2	2.374	¾	1½	1 ¹¹ / ₁₆	¾	—	1⅞	1 ⁷ / ₈	2 ¹³ / ₁₆	5⅞	5 ¹⁵ / ₁₆
20	1⅜	1-14	1¼-12	1⅝	1.999	⅝	1⅞	1 ⁵ / ₁₆	¾	—	1	1 ⁵ / ₈	2 ⁹ / ₁₆	5⅞	6
	2	1½-12	1¾-12	2	2.374	¾	1½	1 ¹¹ / ₁₆	¾	—	1⅞	1 ⁷ / ₈	2 ¹³ / ₁₆	5⅞	5 ¹⁵ / ₁₆

Series 7L

Detachable & Spherical Mounted Cylinders

1.50" to 6.00"

**STYLE R—Detachable
Pivot Mount**
(NFPA Mounting Style MP4)

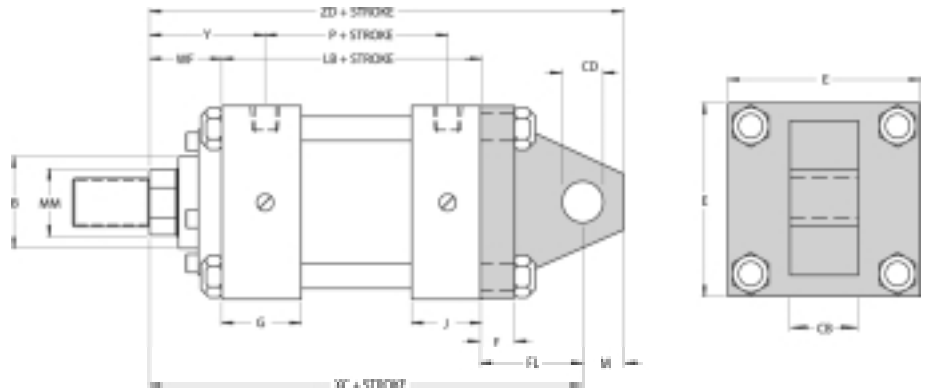

**STYLE Z—Detachable
Clevis Mount**
(NFPA Mounting Style MP2)

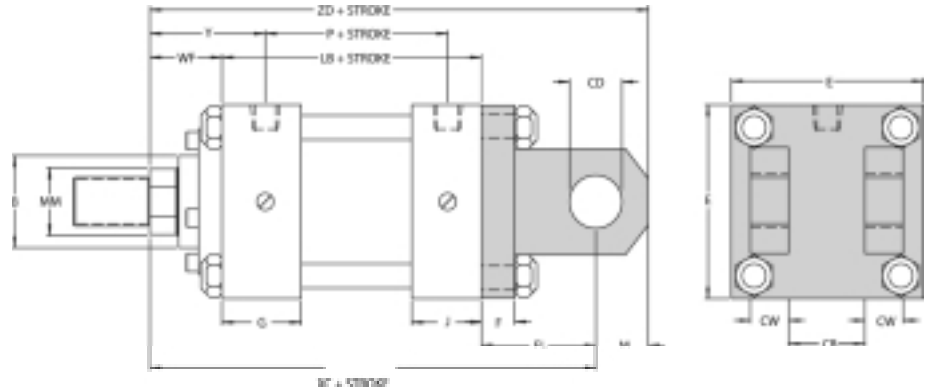

**STYLE SP—Spherical
Bearing Mount**

(Female rod end recommended for use with Spherical Rod Eye accessory)

Cylinders ordered with Rod Eye listed under "Accessories" on page 169 must be ordered with proper female style rod end thread as listed below:

KK = $\frac{7}{16}$ -20 for rod eye with .50 dia. pin; $\frac{3}{4}$ -16 for rod eye with .75 dia. pin; 1-14 for rod eye with 1 dia. pin.

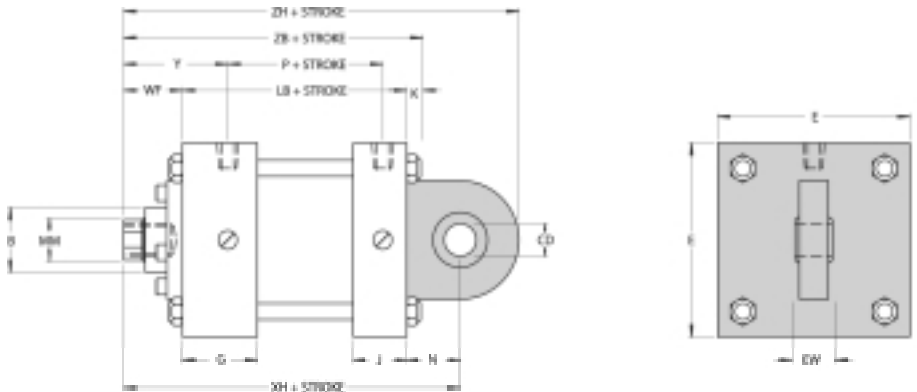

Series 7L
Section 4

BORE	CB	CD	CW	E	EW	EE		F	FL	G	HP	J	K	LH	M	N	ADD STROKE	
						NPTF	SAE										LB	P
1½	¾	½	½	2	.625	¾	6	¾	1⅛	1½	15/16	1	¼	.75	5/8	¾	3⅝	2¼
2	¾	½	½	2½	.625	¾	6	¾	1⅛	1½	15/16	1	5/16	.75	5/8	¾	3⅝	2¼
2½	¾	½	½	3	.625	¾	6	¾	1⅛	1½	15/16	1	5/16	.75	5/8	¾	3¾	2⅝
3¼	1¼	¾	5/8	3¾	.875	½	10	5/8	1⅞	1¾	1⅜	1¼	3/8	1	7/8	1¼	4¼	2⅝
4	1¼	¾	5/8	4½	.875	½	10	5/8	1⅞	1¾	1⅜	1¼	3/8	1	7/8	1¼	4¼	2⅝
5	—	¾	—	5½	.875	½	10	—	—	1¾	1½	1¼	7/16	1	—	1¼	4½	2⅝
6	—	1	—	6½	1.375	¾	12	—	—	2	1⅞	1½	7/16	1.38	—	1½	5	3⅝

BORE	ROD DIA.			THREAD SIZE			ROD EXTENSIONS AND PILOT DIMENSIONS								ADD STROKE			
	MM	KK	FF	A	+000 -002 B	C	D	NA	FA	RD	VB	WF	Y	XC	XH	ZD	ZH	
1½	5/8	7/16-20	1/2-20	¾	1.124	3/8	½	9/16	3/8	2	5/8	1	15/16	5¾	5¾	6¾	6¼	
	1	¾-16	7/8-14	1⅛	1.499	½	7/8	15/16	3/8	—	7/8	1¾	25/16	6⅞	5¾	6¾	6⅝	
2	5/8	7/16-20	1/2-20	¾	1.124	3/8	½	9/16	3/8	2	5/8	1	15/16	5¾	5¾	6¾	6¼	
	1⅜	1-14	1¼-12	1⅝	1.999	5/8	1⅛	15/16	3/8	—	1	15/8	29/16	6¾	6	7	6⅝	
2½	1	¾-16	7/8-14	1⅛	1.499	½	7/8	15/16	3/8	2¾	7/8	1¾	25/16	6¼	5⅝	6⅝	6¾	
	1¾	1¼-12	1½-12	2	2.374	¾	1½	11/16	3/8	—	1⅛	17/8	213/16	6¾	6¾	7¾	7¼	
	1⅜	1-14	1¼-12	1⅝	1.999	5/8	1⅛	15/16	3/8	—	1	15/8	29/16	6½	6⅝	7⅞	7	
	5/8	7/16-20	1/2-20	¾	1.124	3/8	½	9/16	3/8	2	5/8	1	15/16	5⅝	5½	6½	6⅝	
3¼	1	¾-16	7/8-14	1⅛	1.499	½	7/8	15/16	3/8	2¾	7/8	1¾	27/16	7½	6⅝	8¾	8⅝	
	2	1½-12	1¾-12	2¼	2.624	7/8	11/16	15/16	5/8	—	1⅛	2	31/16	8⅞	7½	9	8¾	
	1⅜	1-14	1¼-12	1⅝	1.999	5/8	1⅛	15/16	5/8	3¼	1	15/8	211/16	7¾	7⅝	8⅝	8⅝	
	1¾	1¼-12	1½-12	2	2.374	¾	1½	11/16	5/8	3¾	1⅛	17/8	215/16	8	7¾	8⅝	6⅝	
4	1⅜	1-14	1¼-12	1⅝	1.999	5/8	1⅛	15/16	5/8	3¼	1	15/8	211/16	7¾	6⅝	8⅝	8⅝	
	2½	1⅝-12	2¼-12	3	3.124	1	21/16	2¾	5/8	4½	1¼	2¼	35/16	8¾	7¾	9¼	9	
	1¾	1¼-12	1½-12	2	2.374	¾	1½	11/16	5/8	3¾	1⅛	17/8	215/16	8	7¾	8⅝	8⅝	
	2	1½-12	1¾-12	2¼	2.624	7/8	11/16	15/16	5/8	4⅞	1⅛	2	31/16	8⅞	7½	9	8¾	
	1	¾-16	7/8-14	1⅛	1.499	½	7/8	15/16	3/8	2¾	7/8	1¾	27/16	7½	6⅝	8¾	8⅝	
5	1¾	1¼-12	1½-12	2	2.374	¾	1½	11/16	5/8	3¾	1⅛	17/8	215/16	—	7¾	—	9⅞	
	3½	2½-12	3¼-12	3½	4.249	1	3	3¾	5/8	5½	1¼	2¼	35/16	—	8	—	9½	
	2	1½-12	1¾-12	2¼	2.624	7/8	11/16	15/16	5/8	4⅞	1⅛	2	31/16	—	7¾	—	9¼	
	2½	1⅝-12	2¼-12	3	3.124	1	21/16	2¾	5/8	4½	1¼	2¼	35/16	—	8	—	9½	
	3	2¼-12	2¾-12	3½	3.749	1	25/8	2⅞	5/8	5¼	1¼	2¼	35/16	—	8	—	9½	
	1	¾-16	7/8-14	1⅛	1.499	½	7/8	15/16	3/8	2¾	7/8	1¾	27/16	—	7⅞	—	8⅝	
	1⅜	1-14	1¼-12	1⅝	1.999	5/8	1⅛	15/16	5/8	3¼	1	15/8	211/16	—	7¾	—	8⅝	
6	1¾	1¼-12	1½-12	2	2.374	¾	1½	11/16	5/8	3¾	1⅛	17/8	31/16	—	8¾	—	10¼	
	4	3-12	3¼-12	4	4.749	1	3¾	3⅞	¾	6	1¼	2¼	37/16	—	8¾	—	10¾	
	2	1½-12	1¾-12	2¼	2.624	7/8	11/16	15/16	5/8	4⅞	1⅛	2	33/16	—	8½	—	10½	
	2½	1⅝-12	2¼-12	3	3.124	1	21/16	2¾	5/8	4½	1¼	2¼	37/16	—	8¾	—	10¾	
	3	2¼-12	2¾-12	3½	3.749	1	25/8	2⅞	5/8	5¼	1¼	2¼	37/16	—	8¾	—	10¾	
	3½	2½-12	3¼-12	3½	4.249	1	3	3¾	5/8	5½	1¼	2¼	37/16	—	8¾	—	10¾	
	1⅜	1-14	1¼-12	1⅝	1.999	5/8	1⅛	15/16	5/8	3¼	1	15/8	213/16	—	8⅞	—	10⅞	

Series 7L

Tie Rod Mounted Cylinders

8.00" to 14.00"

STYLE L—Tie Rods
Extended Both Ends
 (NFPA Mounting Style MX1)

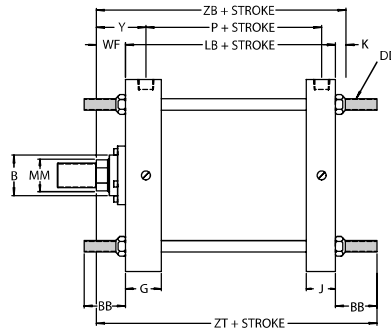
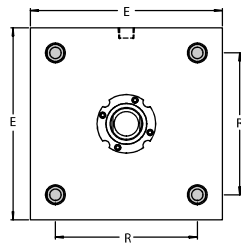

STYLE M—Tie Rods
Extended Head End
 (NFPA Mounting Style MX3)

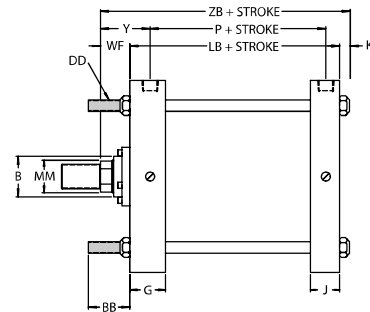
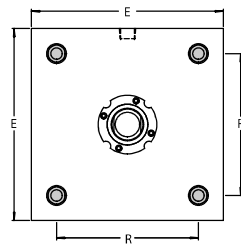

STYLE N—Tie Rods
Extended Cap End
 (NFPA Mounting Style MX2)

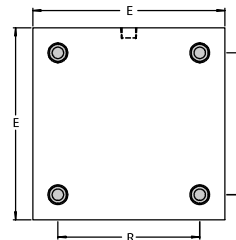
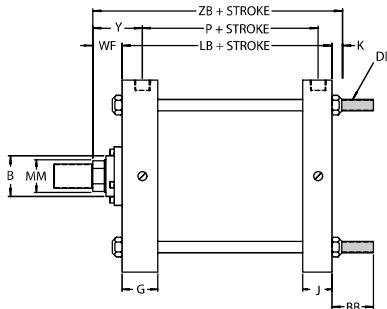

Double rod cylinders are available in all styles except A, AA, EB, and G. Dimensions for other styles are the same as above with mounting added. Add prefix D to style when ordering. Example: DB HYD. CYL.

BB is standard tie rod extension on Styles L, M, N, DL and DM, but will be increased or decreased when specified. To do this, specify BB to be (so many) inches. Extra nuts are available for tie rod ends.

Consult factory on availability of Style DCC cylinder.

ENVELOPE AND MOUNTING DIMENSIONS

BORE	AA	BB	DD	E	EE NPTF	G	J	K	R	ADD STROKE		
										LB	LD	P
8	9.1	2 ⁵ / ₁₆	⁵ / ₈ -18	8 ¹ / ₂	³ / ₄	2	1 ¹ / ₂	⁹ / ₁₆	6.44	5 ¹ / ₈	5 ⁵ / ₈	3 ¹ / ₄
10	11.2	2 ¹¹ / ₁₆	³ / ₄ -16	10 ⁵ / ₈	1	2 ¹ / ₄	2	¹¹ / ₁₆	7.92	6 ³ / ₈	6 ⁵ / ₈	4 ¹ / ₈
12	13.3	2 ¹¹ / ₁₆	³ / ₄ -16	12 ³ / ₄	1	2 ¹ / ₄	2	¹¹ / ₁₆	9.40	6 ⁷ / ₈	7 ¹ / ₈	4 ⁵ / ₈
14	15.4	3 ³ / ₁₆	⁷ / ₈ -14	14 ³ / ₄	1 ¹ / ₄	2 ³ / ₄	2 ¹ / ₄	¹³ / ₁₆	10.90	8 ¹ / ₈	8 ⁵ / ₈	5 ¹ / ₂

ROD END DIMENSIONS

ENVELOPE AND MOUNTING DIMENSIONS

BORE	ROD DIA. MM	THREAD SIZE		ROD EXTENSIONS AND PILOT DIMENSIONS								ADD STROKE		ADD 2X STK.		
		KK	FF	A	+000 -002 B	C	D	NA	FA	RD	VB	WF	Y		ZB	ZT
8	1 ³ / ₈	1-14	1 ¹ / ₄ -12	1 ⁵ / ₈	1.999	⁵ / ₈	1 ¹ / ₈	1 ⁵ / ₁₆	⁵ / ₈	3 ¹ / ₄	1	1 ⁵ / ₈	2 ¹³ / ₁₆	7 ⁵ / ₁₆	9 ¹ / ₁₆	8 ⁷ / ₈
	5 ¹ / ₂	4-12	5 ¹ / ₄ -12	5 ¹ / ₂	6.249	1	4 ⁵ / ₈	5 ³ / ₈	³ / ₄	8	1 ¹ / ₄	2 ¹ / ₄	3 ⁷ / ₁₆	7 ¹⁵ / ₁₆	9 ¹¹ / ₁₆	10 ¹ / ₈
	1 ³ / ₄	1 ¹ / ₄ -12	1 ¹ / ₂ -12	2	2.374	³ / ₄	1 ¹ / ₂	1 ¹¹ / ₁₆	⁵ / ₈	3 ³ / ₄	1 ¹ / ₈	1 ⁷ / ₈	3 ³ / ₁₆	7 ⁹ / ₁₆	9 ⁹ / ₁₆	9 ³ / ₈
	2	1 ¹ / ₂ -12	1 ³ / ₄ -12	2 ¹ / ₄	2.624	⁷ / ₈	1 ¹¹ / ₁₆	1 ¹⁵ / ₁₆	⁵ / ₈	4 ¹ / ₈	1 ¹ / ₈	2	3 ³ / ₁₆	7 ¹¹ / ₁₆	9 ⁷ / ₁₆	9 ⁵ / ₈
	2 ¹ / ₂	1 ⁷ / ₈ -12	2 ¹ / ₄ -12	3	3.124	1	2 ¹ / ₁₆	2 ³ / ₈	⁵ / ₈	4 ¹ / ₂	1 ¹ / ₄	2 ¹ / ₄	3 ³ / ₁₆	7 ¹⁵ / ₁₆	9 ¹¹ / ₁₆	10 ¹ / ₈
	3	2 ¹ / ₄ -12	2 ³ / ₄ -12	3 ¹ / ₂	3.749	1	2 ⁵ / ₈	2 ⁷ / ₈	⁵ / ₈	5 ¹ / ₄	1 ¹ / ₄	2 ¹ / ₄	3 ³ / ₁₆	7 ¹⁵ / ₁₆	9 ¹¹ / ₁₆	10 ¹ / ₈
	3 ¹ / ₂	2 ¹ / ₂ -12	3 ¹ / ₄ -12	3 ¹ / ₂	4.249	1	3	3 ³ / ₈	⁵ / ₈	5 ¹ / ₂	1 ¹ / ₄	2 ¹ / ₄	3 ³ / ₁₆	7 ¹⁵ / ₁₆	9 ¹¹ / ₁₆	10 ¹ / ₈
	4	3-12	3 ³ / ₄ -12	4	4.749	1	3 ³ / ₈	3 ⁷ / ₈	³ / ₄	6	1 ¹ / ₄	2 ¹ / ₄	3 ³ / ₁₆	7 ¹⁵ / ₁₆	9 ¹¹ / ₁₆	10 ¹ / ₈
	4 ¹ / ₂	3 ¹ / ₄ -12	4 ¹ / ₄ -12	4 ¹ / ₂	5.249	1	3 ⁷ / ₈	4 ³ / ₈	³ / ₄	6 ⁷ / ₈	1 ¹ / ₄	2 ¹ / ₄	3 ³ / ₁₆	7 ¹⁵ / ₁₆	9 ¹¹ / ₁₆	10 ¹ / ₈
5	3 ¹ / ₂ -12	4 ³ / ₄ -12	5	5.749	1	4 ¹ / ₄	4 ⁷ / ₈	³ / ₄	7 ¹ / ₄	1 ¹ / ₄	2 ¹ / ₄	3 ³ / ₁₆	7 ¹⁵ / ₁₆	9 ¹¹ / ₁₆	10 ¹ / ₈	
10	1 ³ / ₄	1 ¹ / ₄ -12	1 ¹ / ₂ -12	2	2.374	³ / ₄	1 ¹ / ₂	1 ¹¹ / ₁₆	⁵ / ₈	3 ³ / ₄	1 ¹ / ₈	1 ⁷ / ₈	3 ³ / ₈	8 ¹⁵ / ₁₆	10 ¹⁵ / ₁₆	10 ³ / ₈
	5 ¹ / ₂	4-12	5 ¹ / ₄ -12	5 ¹ / ₂	6.249	1	4 ⁵ / ₈	5 ³ / ₈	³ / ₄	8	1 ¹ / ₄	2 ¹ / ₄	3 ¹ / ₂	9 ⁵ / ₁₆	11 ⁵ / ₁₆	11 ¹ / ₈
	2	1 ¹ / ₂ -12	1 ³ / ₄ -12	2 ¹ / ₄	2.624	⁷ / ₈	1 ¹¹ / ₁₆	1 ¹⁵ / ₁₆	⁵ / ₈	4 ¹ / ₈	1 ¹ / ₈	2	3 ³ / ₄	9 ⁹ / ₁₆	11 ⁹ / ₁₆	10 ⁵ / ₈
	2 ¹ / ₂	1 ⁷ / ₈ -12	2 ¹ / ₄ -12	3	3.124	1	2 ¹ / ₁₆	2 ³ / ₈	⁵ / ₈	4 ¹ / ₂	1 ¹ / ₄	2 ¹ / ₄	3 ³ / ₂	9 ⁵ / ₁₆	11 ⁵ / ₁₆	11 ¹ / ₈
	3	2 ¹ / ₄ -12	2 ³ / ₄ -12	3 ¹ / ₂	3.749	1	2 ⁵ / ₈	2 ⁷ / ₈	⁵ / ₈	5 ¹ / ₄	1 ¹ / ₄	2 ¹ / ₄	3 ³ / ₂	9 ⁵ / ₁₆	11 ⁵ / ₁₆	11 ¹ / ₈
	3 ¹ / ₂	2 ¹ / ₂ -12	3 ¹ / ₄ -12	3 ¹ / ₂	4.249	1	3	3 ³ / ₈	⁵ / ₈	5 ¹ / ₂	1 ¹ / ₄	2 ¹ / ₄	3 ³ / ₂	9 ⁵ / ₁₆	11 ⁵ / ₁₆	11 ¹ / ₈
	4	3-12	3 ³ / ₄ -12	4	4.749	1	3 ³ / ₈	3 ⁷ / ₈	³ / ₄	6	1 ¹ / ₄	2 ¹ / ₄	3 ³ / ₂	9 ⁵ / ₁₆	11 ⁵ / ₁₆	11 ¹ / ₈
	4 ¹ / ₂	3 ¹ / ₄ -12	4 ¹ / ₄ -12	4 ¹ / ₂	5.249	1	3 ⁷ / ₈	4 ³ / ₈	³ / ₄	6 ⁷ / ₈	1 ¹ / ₄	2 ¹ / ₄	3 ³ / ₂	9 ⁵ / ₁₆	11 ⁵ / ₁₆	11 ¹ / ₈
	5	3 ¹ / ₂ -12	4 ³ / ₄ -12	5	5.749	1	4 ¹ / ₄	4 ⁷ / ₈	³ / ₄	7 ¹ / ₄	1 ¹ / ₄	2 ¹ / ₄	3 ³ / ₂	9 ⁵ / ₁₆	11 ⁵ / ₁₆	11 ¹ / ₈
12	2	1 ¹ / ₂ -12	1 ³ / ₄ -12	2 ¹ / ₄	2.624	⁷ / ₈	1 ¹¹ / ₁₆	1 ¹⁵ / ₁₆	⁵ / ₈	4 ¹ / ₈	1 ¹ / ₈	2	3 ³ / ₄	9 ⁹ / ₁₆	11 ⁹ / ₁₆	11 ¹ / ₈
	5 ¹ / ₂	4-12	5 ¹ / ₄ -12	5 ¹ / ₂	6.249	1	4 ⁵ / ₈	5 ³ / ₈	³ / ₄	8	1 ¹ / ₄	2 ¹ / ₄	3 ¹ / ₂	9 ¹³ / ₁₆	11 ¹³ / ₁₆	11 ⁵ / ₈
	2 ¹ / ₂	1 ⁷ / ₈ -12	2 ¹ / ₄ -12	3	3.124	1	2 ¹ / ₁₆	2 ³ / ₈	⁵ / ₈	4 ¹ / ₂	1 ¹ / ₄	2 ¹ / ₄	3 ³ / ₂	9 ¹³ / ₁₆	11 ¹³ / ₁₆	11 ⁵ / ₈
	3	2 ¹ / ₄ -12	2 ³ / ₄ -12	3 ¹ / ₂	3.749	1	2 ⁵ / ₈	2 ⁷ / ₈	⁵ / ₈	5 ¹ / ₄	1 ¹ / ₄	2 ¹ / ₄	3 ³ / ₂	9 ¹³ / ₁₆	11 ¹³ / ₁₆	11 ⁵ / ₈
	3 ¹ / ₂	2 ¹ / ₂ -12	3 ¹ / ₄ -12	3 ¹ / ₂	4.249	1	3	3 ³ / ₈	⁵ / ₈	5 ¹ / ₂	1 ¹ / ₄	2 ¹ / ₄	3 ³ / ₂	9 ¹³ / ₁₆	11 ¹³ / ₁₆	11 ⁵ / ₈
	4	3-12	3 ³ / ₄ -12	4	4.749	1	3 ³ / ₈	3 ⁷ / ₈	³ / ₄	6	1 ¹ / ₄	2 ¹ / ₄	3 ³ / ₂	9 ¹³ / ₁₆	11 ¹³ / ₁₆	11 ⁵ / ₈
	4 ¹ / ₂	3 ¹ / ₄ -12	4 ¹ / ₄ -12	4 ¹ / ₂	5.249	1	3 ⁷ / ₈	4 ³ / ₈	³ / ₄	6 ⁷ / ₈	1 ¹ / ₄	2 ¹ / ₄	3 ³ / ₂	9 ¹³ / ₁₆	11 ¹³ / ₁₆	11 ⁵ / ₈
	5	3 ¹ / ₂ -12	4 ³ / ₄ -12	5	5.749	1	4 ¹ / ₄	4 ⁷ / ₈	³ / ₄	7 ¹ / ₄	1 ¹ / ₄	2 ¹ / ₄	3 ³ / ₂	9 ¹³ / ₁₆	11 ¹³ / ₁₆	11 ⁵ / ₈
	2 ¹ / ₂	1 ⁷ / ₈ -12	2 ¹ / ₄ -12	3	3.124	1	2 ¹ / ₁₆	2 ³ / ₈	⁵ / ₈	4 ¹ / ₂	1 ¹ / ₄	2 ¹ / ₄	3 ³ / ₁₆	11 ³ / ₁₆	13 ³ / ₁₆	13 ³ / ₈
5 ¹ / ₂	4-12	5 ¹ / ₄ -12	5 ¹ / ₂	6.249	1	4 ⁵ / ₈	5 ³ / ₈	³ / ₄	8	1 ¹ / ₄	2 ¹ / ₄	3 ³ / ₁₆	11 ³ / ₁₆	13 ³ / ₁₆	13 ³ / ₈	
14	3	2 ¹ / ₄ -12	2 ³ / ₄ -12	3 ¹ / ₂	3.749	1	2 ⁵ / ₈	2 ⁷ / ₈	⁵ / ₈	5 ¹ / ₄	1 ¹ / ₄	2 ¹ / ₄	3 ³ / ₁₆	11 ³ / ₁₆	13 ³ / ₁₆	13 ³ / ₈
	3 ¹ / ₂	2 ¹ / ₂ -12	3 ¹ / ₄ -12	3 ¹ / ₂	4.249	1	3	3 ³ / ₈	⁵ / ₈	5 ¹ / ₂	1 ¹ / ₄	2 ¹ / ₄	3 ³ / ₁₆	11 ³ / ₁₆	13 ³ / ₁₆	13 ³ / ₈
	4	3-12	3 ³ / ₄ -12	4	4.749	1	3 ³ / ₈	3 ⁷ / ₈	³ / ₄	6	1 ¹ / ₄	2 ¹ / ₄	3 ³ / ₁₆	11 ³ / ₁₆	13 ³ / ₁₆	13 ³ / ₈
	4 ¹ / ₂	3 ¹ / ₄ -12	4 ¹ / ₄ -12	4 ¹ / ₂	5.249	1	3 ⁷ / ₈	4 ³ / ₈	³ / ₄	6 ⁷ / ₈	1 ¹ / ₄	2 ¹ / ₄	3 ³ / ₁₆	11 ³ / ₁₆	13 ³ / ₁₆	13 ³ / ₈
	5	3 ¹ / ₂ -12	4 ³ / ₄ -12	5	5.749	1	4 ¹ / ₄	4 ⁷ / ₈	³ / ₄	7 ¹ / ₄	1 ¹ / ₄	2 ¹ / ₄	3 ³ / ₁₆	11 ³ / ₁₆	13 ³ / ₁₆	13 ³ / ₈

Series 7L

Foot Mounted Cylinders

8.00" to 14.00"

STYLE J—Side Lug Mount
(NFPA Mounting Style MS2)

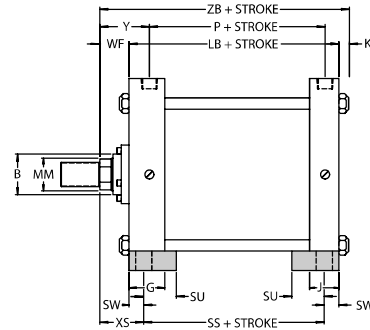
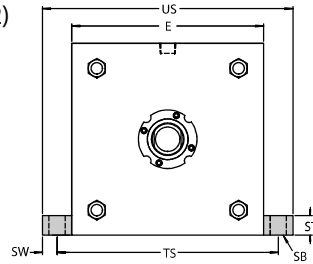

STYLE K—Center Line Mount
(NFPA Mounting Style MS3)

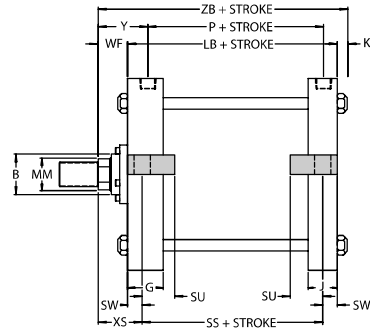
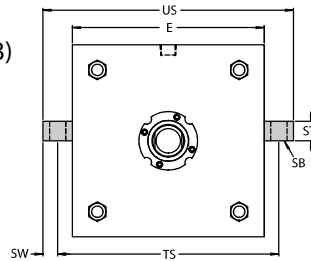

STYLE CC—Foot Mount
(NFPA Mounting Style MS7)

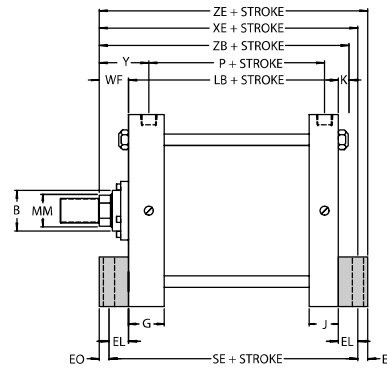
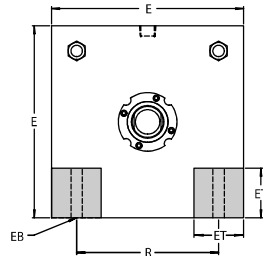

STYLE H—Side Flush Mount
(NFPA Mounting Style MS4)

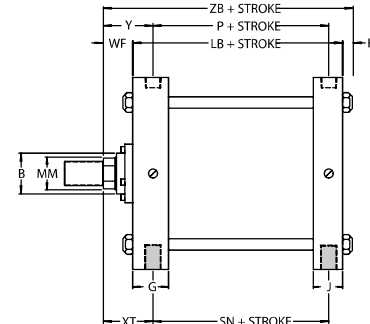
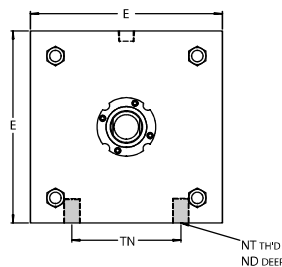

ENVELOPE AND MOUNTING DIMENSIONS

	E	EB*	EE NPTF	EL	EO	ET	G	J	K	ND	NT	R	SB*	ST	SU	SW	TN	TS	US	ADD STROKE				
																				LB	P	SE	SN	SS
8	8 1/2	5/8	3/4	1 1/8	5/8	2 1/16	2	1 1/2	9/16	1 1/8	3/4-10	6.44	3/4	1	1 9/16	1 1/16	4 1/2	9 7/8	11 1/4	5 1/8	3 1/4	7 3/8	3 1/4	3 3/4
10	10 5/8	3/4	1	1 5/16	5/8	2 11/16	2 1/4	2	11/16	1 1/2	1-8	7.92	1	1 1/4	2	7/8	5 1/2	12 3/8	14 1/8	6 3/8	4 1/8	9	4 1/8	4 5/8
12	12 3/4	3/4	1	1 5/16	5/8	3 5/16	2 1/4	2	11/16	1 1/2	1-8	9.40	1	1 1/4	2	7/8	7 1/4	14 1/2	16 1/4	6 7/8	4 3/8	9 1/2	4 5/8	5 1/8
14	14 3/4	7/8	1 1/4	1 1/2	3/4	3 13/16	2 3/4	2 1/4	13/16	1 7/8	1 1/4-7	10.90	1 1/4	1 1/2	2 1/2	1 1/8	8 3/8	17	19 1/4	8 1/8	5 1/2	11 1/8	5 1/2	5 7/8

Styles J, H, K and CC should be pinned or keyed at one end to prevent shifting. *Mounting holes are 1/16" larger than screw size shown.

ENVELOPE AND MOUNTING DIMENSIONS

BORE	ROD END DIMENSIONS														ADD STROKE			
	ROD DIA.	THREAD SIZE		ROD EXTENSIONS AND PILOT DIMENSIONS										ADD STROKE				
	MM	KK	FF	A	+000 -002 B	C	D	NA	FA	RD	VB	WF	Y	XS	XT	XE	ZB	ZE
8	1 3/8	1-14	1 1/4-12	1 5/8	1.999	5/8	1 1/8	1 5/16	5/8	3 1/4	1	1 5/8	2 13/16	2 5/16	2 13/16	7 7/8	7 5/16	8 1/2
	5 1/2*	4-12	5 1/4-12	5 1/2	6.249	1	4 5/8	5 3/8	3/4	8	1 1/4	2 1/4	3 7/16	2 15/16	3 7/16	8 1/2	7 15/16	9 1/8
	1 3/4	1 1/4-12	1 1/2-12	2	2.374	3/4	1 1/2	1 11/16	5/8	3 3/4	1 1/8	1 7/8	3 1/16	2 9/16	3 1/16	8 1/8	7 9/16	8 3/4
	2	1 1/2-12	1 3/4-12	2 1/4	2.624	7/8	1 11/16	1 15/16	5/8	4 1/8	1 1/8	2	3 3/16	2 11/16	3 3/16	8 1/4	7 11/16	8 7/8
	2 1/2	1 7/8-12	2 1/4-12	3	3.124	1	2 1/16	2 3/8	5/8	4 1/2	1 1/4	2 1/4	3 7/16	2 15/16	3 7/16	8 1/2	7 15/16	9 1/8
	3	2 1/4-12	2 3/4-12	3 1/2	3.749	1	2 5/8	2 7/8	5/8	5 1/4	1 1/4	2 1/4	3 7/16	2 15/16	3 7/16	8 1/2	7 15/16	9 1/8
	3 1/2	2 1/2-12	3 1/4-12	3 1/2	4.249	1	3	3 3/8	5/8	5 1/2	1 1/4	2 1/4	3 7/16	2 15/16	3 7/16	8 1/2	7 15/16	9 1/8
	4	3-12	3 3/4-12	4	4.749	1	3 3/8	3 7/8	3/4	6	1 1/4	2 1/4	3 7/16	2 15/16	3 7/16	8 1/2	7 15/16	9 1/8
	4 1/2*	3 1/4-12	4 1/4-12	4 1/2	5.249	1	3 7/8	4 3/8	3/4	6 7/8	1 1/4	2 1/4	3 7/16	2 15/16	3 7/16	8 1/2	7 15/16	9 1/8
5*	3 1/2-12	4 3/4-12	5	5.749	1	4 1/4	4 7/8	3/4	7 1/4	1 1/4	2 1/4	3 7/16	2 15/16	3 7/16	8 1/2	7 15/16	9 1/8	
10	1 3/4	1 1/4-12	1 1/2-12	2	2.374	3/4	1 1/2	1 11/16	5/8	3 3/4	1 1/8	1 7/8	3 1/8	2 3/4	3 1/8	9 9/16	8 15/16	10 3/16
	5 1/2*	4-12	5 1/4-12	5 1/2	6.249	1	4 5/8	5 3/8	3/4	8	1 1/4	2 1/4	3 1/2	3 1/8	3 1/2	9 9/16	9 9/16	10 9/16
	2	1 1/2-12	1 3/4-12	2 1/4	2.624	7/8	1 11/16	1 15/16	5/8	4 1/8	1 1/8	2	3 1/4	2 7/8	3 1/4	9 1/16	9 1/16	10 5/16
	2 1/2	1 7/8-12	2 1/4-12	3	3.124	1	2 1/16	2 3/8	5/8	4 1/2	1 1/4	2 1/4	3 1/2	3 1/8	3 1/2	9 9/16	9 9/16	10 9/16
	3	2 1/4-12	2 3/4-12	3 1/2	3.749	1	2 5/8	2 7/8	5/8	5 1/4	1 1/4	2 1/4	3 1/2	3 1/8	3 1/2	9 9/16	9 9/16	10 9/16
	3 1/2	2 1/2-12	3 1/4-12	3 1/2	4.249	1	3	3 3/8	5/8	5 1/2	1 1/4	2 1/4	3 1/2	3 1/8	3 1/2	9 9/16	9 9/16	10 9/16
	4	3-12	3 3/4-12	4	4.749	1	3 3/8	3 7/8	3/4	6	1 1/4	2 1/4	3 1/2	3 1/8	3 1/2	9 9/16	9 9/16	10 9/16
	4 1/2	3 1/4-12	4 1/4-12	4 1/2	5.249	1	3 7/8	4 3/8	3/4	6 7/8	1 1/4	2 1/4	3 1/2	3 1/8	3 1/2	9 9/16	9 9/16	10 9/16
	5	3 1/2-12	4 3/4-12	5	5.749	1	4 1/4	4 7/8	3/4	7 1/4	1 1/4	2 1/4	3 1/2	3 1/8	3 1/2	9 9/16	9 9/16	10 9/16
12	2	1 1/2-12	1 3/4-12	2 1/4	2.624	7/8	1 11/16	1 15/16	5/8	4 1/8	1 1/8	2	3 1/4	2 7/8	3 1/4	10 3/16	9 9/16	10 13/16
	5 1/2	4-12	5 1/4-12	5 1/2	6.249	1	4 5/8	5 3/8	3/4	8	1 1/4	2 1/4	3 1/2	3 1/8	3 1/2	10 7/16	9 13/16	11 1/16
	2 1/2	1 7/8-12	2 1/4-12	3	3.124	1	2 1/16	2 3/8	5/8	4 1/2	1 1/4	2 1/4	3 1/2	3 1/8	3 1/2	10 7/16	9 13/16	11 1/16
	3	2 1/4-12	2 3/4-12	3 1/2	3.749	1	2 5/8	2 7/8	5/8	5 1/4	1 1/4	2 1/4	3 1/2	3 1/8	3 1/2	10 7/16	9 13/16	11 1/16
	3 1/2	2 1/2-12	3 1/4-12	3 1/2	4.249	1	3	3 3/8	5/8	5 1/2	1 1/4	2 1/4	3 1/2	3 1/8	3 1/2	10 7/16	9 13/16	11 1/16
	4	3-12	3 3/4-12	4	4.749	1	3 3/8	3 7/8	3/4	6	1 1/4	2 1/4	3 1/2	3 1/8	3 1/2	10 7/16	9 13/16	11 1/16
	4 1/2	3 1/4-12	4 1/4-12	4 1/2	5.249	1	3 7/8	4 3/8	3/4	6 7/8	1 1/4	2 1/4	3 1/2	3 1/8	3 1/2	10 7/16	9 13/16	11 1/16
	5	3 1/2-12	4 3/4-12	5	5.749	1	4 1/4	4 7/8	3/4	7 1/4	1 1/4	2 1/4	3 1/2	3 1/8	3 1/2	10 7/16	9 13/16	11 1/16
	14	2 1/2	1 7/8-12	2 1/4-12	3	3.124	1	2 1/16	2 3/8	5/8	4 1/2	1 1/4	2 1/4	3 13/16	3 3/8	3 13/16	11 7/8	11 3/16
5 1/2		4-12	5 1/4-12	5 1/2	6.249	1	4 5/8	5 3/8	3/4	8	1 1/4	2 1/4	3 13/16	3 3/8	3 13/16	11 7/8	11 3/16	12 5/8
3		2 1/4-12	2 3/4-12	3 1/2	3.749	1	2 5/8	2 7/8	5/8	5 1/4	1 1/4	2 1/4	3 13/16	3 3/8	3 13/16	11 7/8	11 3/16	12 5/8
3 1/2		2 1/2-12	3 1/4-12	3 1/2	4.249	1	3	3 3/8	5/8	5 1/2	1 1/4	2 1/4	3 13/16	3 3/8	3 13/16	11 7/8	11 3/16	12 5/8
4		3-12	3 3/4-12	4	4.749	1	3 3/8	3 7/8	3/4	6	1 1/4	2 1/4	3 13/16	3 3/8	3 13/16	11 7/8	11 3/16	12 5/8
4 1/2		3 1/4-12	4 1/4-12	4 1/2	5.249	1	3 7/8	4 3/8	3/4	6 7/8	1 1/4	2 1/4	3 13/16	3 3/8	3 13/16	11 7/8	11 3/16	12 5/8
5	3 1/2-12	4 3/4-12	5	5.749	1	4 1/4	4 7/8	3/4	7 1/4	1 1/4	2 1/4	3 13/16	3 3/8	3 13/16	11 7/8	11 3/16	12 5/8	

*Not available in Style CC

Series 7L

Pivot Mounted Cylinders

8.00" to 14.00"

STYLE ER—Trunnion Mount
Head End
 (NFPA Mounting Style MT1)

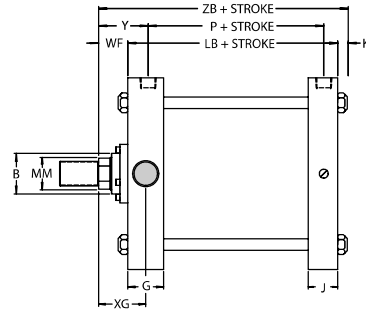
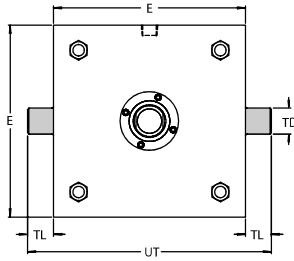

STYLE EB—Trunnion Mount
Cap End
 (NFPA Mounting Style MT2)

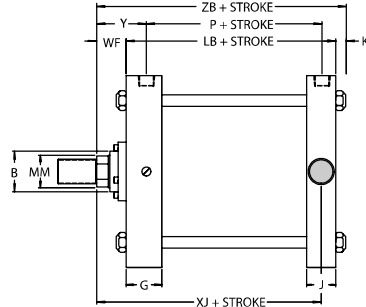
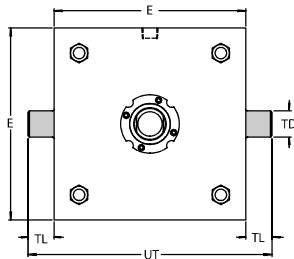

STYLE E—Intermediate
Trunnion Mount
 (NFPA Mounting Style MT4)

Customer to specify Trunnion Location (XI Dim.)

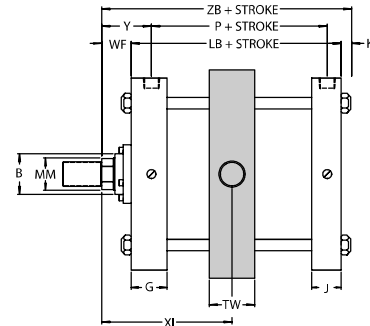
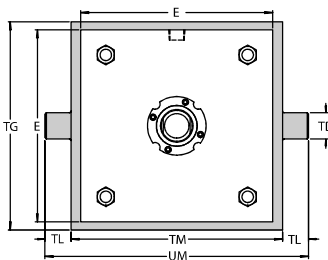

STYLE G—Clevis Mount
 (NFPA Mounting Style MP1)

Chrome-plated Clevis Pin Assembly (with Snap Rings) is furnished with all Style G cylinders.

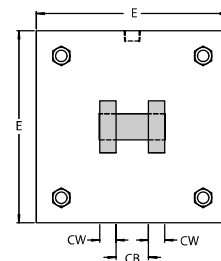
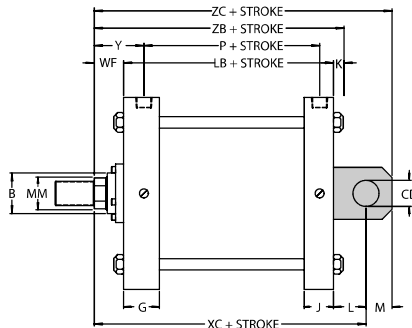

ENVELOPE AND MOUNTING DIMENSIONS

BORE	CB	±001 CD	CW	E	EE NPTF	G	J	K	L	LR	M	NR	+000 -001 TD	TL	TG	TM	TW	UM	UT	ADD STROKE	
																				LB	P
8	1½	1	¾	8½	¾	2	1½	9/16	1½	1 ⁵ / ₁₆	1	1/8	1 ³ / ₈	1 ³ / ₈	9½	9¾	2½	12½	11¼	5/8	3/4
10	2	1 ³ / ₈	1	10 ⁵ / ₈	1	2¼	2	1 ¹ / ₁₆	2/8	1¾	1 ³ / ₈	1½	1¾	1¾	11¾	12	3	15½	14½	6 ³ / ₈	4/8
12	2½	1¾	1¼	12¾	1	2¼	2	1 ¹ / ₁₆	2¼	2	1¾	1 ¹⁵ / ₁₆	1¾	1¾	13¾	14	3	17½	16¼	6 ⁷ / ₈	4 ⁵ / ₈
14	2½	2	1¼	14¾	1¼	2¾	2¼	1 ³ / ₁₆	2½	2¼	2	2 ³ / ₁₆	2	2	16	16¼	3½	20¼	18¾	8/8	5/2

Pintles on trunnion mounted cylinders are designed to withstand shear loads, but not high bending loads. Pillow blocks must be rigidly mounted to provide full support with minimum clearances.

ROD END DIMENSIONS

**ENVELOPE AND
MOUNTING
DIMENSIONS**

BORE	ROD DIA.	THREAD SIZE		ROD EXTENSIONS AND PILOT DIMENSIONS								ADD STROKE							
		MM	KK	FF	A	+000 -002 B	C	D	NA	FA	RD	VB	WF	Y	XG	XI MIN.	XC	XJ	ZB
8	1 ³ / ₈	1-14	1¼-12	1 ⁵ / ₈	1.999	¾	1/8	1 ⁵ / ₁₆	¾	3¼	1	1/8	2 ¹³ / ₁₆	2 ⁵ / ₈	4/8	8¼	6	7 ⁵ / ₁₆	9¼
	5½	4-12	5¼-12	5½	6.249	1	4 ⁵ / ₈	5 ⁵ / ₈	¾	8	1¼	2¼	3 ⁷ / ₁₆	3¼	5½	8 ⁷ / ₈	6 ⁵ / ₈	7 ¹⁵ / ₁₆	9 ⁷ / ₈
	1¾	1¼-12	1½-12	2	2.374	¾	1½	1 ¹¹ / ₁₆	¾	3¼	1/8	1/8	3 ¹ / ₁₆	2 ⁷ / ₈	5/8	8½	6¼	7 ⁹ / ₁₆	9½
	2	1½-12	1¾-12	2¼	2.624	7/8	1 ¹¹ / ₁₆	1 ¹⁵ / ₁₆	¾	4/8	1/8	2	3 ³ / ₁₆	3	5¼	8 ⁵ / ₈	6 ³ / ₈	7 ¹¹ / ₁₆	9 ⁵ / ₈
	2½	1 ⁷ / ₈ -12	2¼-12	3	3.124	1	2 ¹ / ₁₆	2 ³ / ₈	¾	4½	1¼	2¼	3 ⁷ / ₁₆	3¼	5½	8 ⁷ / ₈	6 ⁵ / ₈	7 ¹⁵ / ₁₆	9 ⁷ / ₈
	3	2¼-12	2¾-12	3½	3.749	1	2 ⁵ / ₈	2 ⁷ / ₈	¾	5¼	1¼	2¼	3 ⁷ / ₁₆	3¼	5½	8 ⁷ / ₈	6 ⁵ / ₈	7 ¹⁵ / ₁₆	9 ⁷ / ₈
	3½	2½-12	3¼-12	3½	4.249	1	3	3 ³ / ₈	¾	5½	1¼	2¼	3 ⁷ / ₁₆	3¼	5½	8 ⁷ / ₈	6 ⁵ / ₈	7 ¹⁵ / ₁₆	9 ⁷ / ₈
	4	3-12	3¾-12	4	4.749	1	3 ³ / ₈	3 ⁷ / ₈	¾	6	1¼	2¼	3 ⁷ / ₁₆	3¼	5½	8 ⁷ / ₈	6 ⁵ / ₈	7 ¹⁵ / ₁₆	9 ⁷ / ₈
	4½	3¼-12	4¼-12	4½	5.249	1	3 ⁷ / ₈	4 ³ / ₈	¾	6 ⁷ / ₈	1¼	2¼	3 ⁷ / ₁₆	3¼	5½	8 ⁷ / ₈	6 ⁵ / ₈	7 ¹⁵ / ₁₆	9 ⁷ / ₈
5	3½-12	4¾-12	5	5.749	1	4¼	4 ⁷ / ₈	¾	7¼	1¼	2¼	3 ⁷ / ₁₆	3¼	5½	8 ⁷ / ₈	6 ⁵ / ₈	7 ¹⁵ / ₁₆	9 ⁷ / ₈	
10	1¾	1¼-12	1½-12	2	2.374	¾	1½	1 ¹¹ / ₁₆	¾	3¼	1/8	1/8	3 ¹ / ₈	3	5/8	10 ³ / ₈	7¼	8 ¹⁵ / ₁₆	11¾
	5½	4-12	5¼-12	5½	6.249	1	4 ⁵ / ₈	5 ⁵ / ₈	¾	8	1¼	2¼	3½	3 ³ / ₈	6	10¾	7 ⁵ / ₈	9 ⁵ / ₁₆	12 ⁷ / ₈
	2	1½-12	1¾-12	2¼	2.624	7/8	1 ¹¹ / ₁₆	1 ¹⁵ / ₁₆	¾	4/8	1/8	2	3¼	3 ¹ / ₈	5¼	10½	7 ³ / ₈	9 ¹ / ₁₆	11 ⁷ / ₈
	2½	1 ⁷ / ₈ -12	2¼-12	3	3.124	1	2 ¹ / ₁₆	2 ³ / ₈	¾	4½	1¼	2¼	3½	3 ³ / ₈	6	10¾	7 ⁵ / ₈	9 ⁵ / ₁₆	12 ⁷ / ₈
	3	2¼-12	2¾-12	3½	3.749	1	2 ⁵ / ₈	2 ⁷ / ₈	¾	5¼	1¼	2¼	3½	3 ³ / ₈	6	10¾	7 ⁵ / ₈	9 ⁵ / ₁₆	12 ⁷ / ₈
	3½	2½-12	3¼-12	3½	4.249	1	3	3 ³ / ₈	¾	5½	1¼	2¼	3½	3 ³ / ₈	6	10¾	7 ⁵ / ₈	9 ⁵ / ₁₆	12 ⁷ / ₈
	4	3-12	3¾-12	4	4.749	1	3 ³ / ₈	3 ⁷ / ₈	¾	6	1¼	2¼	3½	3 ³ / ₈	6	10¾	7 ⁵ / ₈	9 ⁵ / ₁₆	12 ⁷ / ₈
	4½	3¼-12	4¼-12	4½	5.249	1	3 ⁷ / ₈	4 ³ / ₈	¾	6 ⁷ / ₈	1¼	2¼	3½	3 ³ / ₈	6	10¾	7 ⁵ / ₈	9 ⁵ / ₁₆	12 ⁷ / ₈
5	3½-12	4¾-12	5	5.749	1	4¼	4 ⁷ / ₈	¾	7¼	1¼	2¼	3½	3 ³ / ₈	6	10¾	7 ⁵ / ₈	9 ⁵ / ₁₆	12 ⁷ / ₈	
12	2	1½-12	1¾-12	2¼	2.624	7/8	1 ¹¹ / ₁₆	1 ¹⁵ / ₁₆	¾	4/8	1/8	2	3¼	3 ¹ / ₈	5¼	11 ¹ / ₈	7 ⁷ / ₈	9 ¹ / ₁₆	12 ⁷ / ₈
	5½	4-12	5¼-12	5½	6.249	1	4 ⁵ / ₈	5 ⁵ / ₈	¾	8	1¼	2¼	3½	3 ³ / ₈	6	11 ³ / ₈	8 ¹ / ₈	9 ¹³ / ₁₆	13 ⁷ / ₈
	2½	1 ⁷ / ₈ -12	2¼-12	3	3.124	1	2 ¹ / ₁₆	2 ³ / ₈	¾	4½	1¼	2¼	3½	3 ³ / ₈	6	11 ³ / ₈	8 ¹ / ₈	9 ¹³ / ₁₆	13 ⁷ / ₈
	3	2¼-12	2¾-12	3½	3.749	1	2 ⁵ / ₈	2 ⁷ / ₈	¾	5¼	1¼	2¼	3½	3 ³ / ₈	6	11 ³ / ₈	8 ¹ / ₈	9 ¹³ / ₁₆	13 ⁷ / ₈
	3½	2½-12	3¼-12	3½	4.249	1	3	3 ³ / ₈	¾	5½	1¼	2¼	3½	3 ³ / ₈	6	11 ³ / ₈	8 ¹ / ₈	9 ¹³ / ₁₆	13 ⁷ / ₈
	4	3-12	3¾-12	4	4.749	1	3 ³ / ₈	3 ⁷ / ₈	¾	6	1¼	2¼	3½	3 ³ / ₈	6	11 ³ / ₈	8 ¹ / ₈	9 ¹³ / ₁₆	13 ⁷ / ₈
	4½	3¼-12	4¼-12	4½	5.249	1	3 ⁷ / ₈	4 ³ / ₈	¾	6 ⁷ / ₈	1¼	2¼	3½	3 ³ / ₈	6	11 ³ / ₈	8 ¹ / ₈	9 ¹³ / ₁₆	13 ⁷ / ₈
5	3½-12	4¾-12	5	5.749	1	4¼	4 ⁷ / ₈	¾	7¼	1¼	2¼	3½	3 ³ / ₈	6	11 ³ / ₈	8 ¹ / ₈	9 ¹³ / ₁₆	13 ⁷ / ₈	
14	2½	1 ⁷ / ₈ -12	2¼-12	3	3.124	1	2 ¹ / ₁₆	2 ³ / ₈	¾	4½	1¼	2¼	3 ¹³ / ₁₆	3 ⁵ / ₈	6¼	12 ⁷ / ₈	9¼	11 ³ / ₁₆	14 ⁷ / ₈
	5½	4-12	5¼-12	5½	6.249	1	4 ⁵ / ₈	5 ⁵ / ₈	¾	8	1¼	2¼	3 ¹³ / ₁₆	3 ⁵ / ₈	6¼	12 ⁷ / ₈	9¼	11 ³ / ₁₆	14 ⁷ / ₈
	3	2¼-12	2¾-12	3½	3.749	1	2 ⁵ / ₈	2 ⁷ / ₈	¾	5¼	1¼	2¼	3 ¹³ / ₁₆	3 ⁵ / ₈	6¼	12 ⁷ / ₈	9¼	11 ³ / ₁₆	14 ⁷ / ₈
	3½	2½-12	3¼-12	3½	4.249	1	3	3 ³ / ₈	¾	5½	1¼	2¼	3 ¹³ / ₁₆	3 ⁵ / ₈	6¼	12 ⁷ / ₈	9¼	11 ³ / ₁₆	14 ⁷ / ₈
	4	3-12	3¾-12	4	4.749	1	3 ³ / ₈	3 ⁷ / ₈	¾	6	1¼	2¼	3 ¹³ / ₁₆	3 ⁵ / ₈	6¼	12 ⁷ / ₈	9¼	11 ³ / ₁₆	14 ⁷ / ₈
	4½	3¼-12	4¼-12	4½	5.249	1	3 ⁷ / ₈	4 ³ / ₈	¾	6 ⁷ / ₈	1¼	2¼	3 ¹³ / ₁₆	3 ⁵ / ₈	6¼	12 ⁷ / ₈	9¼	11 ³ / ₁₆	14 ⁷ / ₈
5	3½-12	4¾-12	5	5.749	1	4¼	4 ⁷ / ₈	¾	7¼	1¼	2¼	3 ¹³ / ₁₆	3 ⁵ / ₈	6¼	12 ⁷ / ₈	9¼	11 ³ / ₁₆	14 ⁷ / ₈	

Series 7L

Heavy Duty Flange Mounted Cylinders

8.00" to 14.00"

Series 7L
Section 4

STYLE QQ—Square Head End Mount
(NFPA Mounting Style ME3)

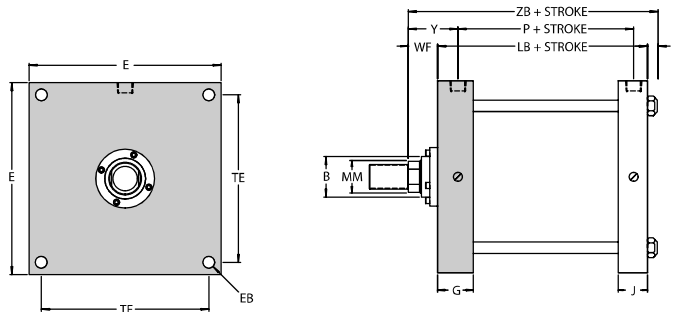

STYLE PP—Square Cap End Mount
(NFPA Mounting Style ME4)

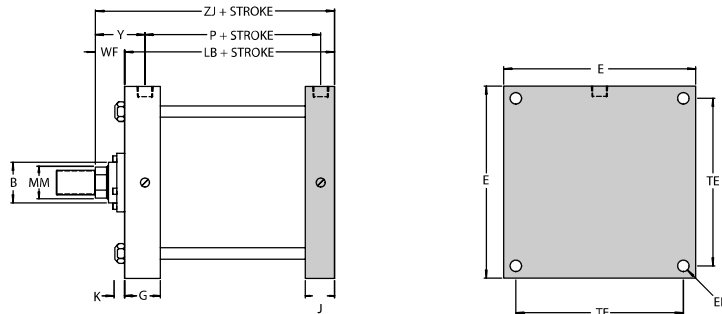

Use socket head cap screws for mounting Styles "QQ" and "PP" 8" bore cylinders, because of tie rod interference with hex bolt heads. We recommend the use of high tensile mounting bolts on all flange mounted cylinders subjected to maximum pressures and shock loads.

ENVELOPE AND MOUNTING DIMENSIONS

BORE	E	EE NPTF	EB*	G	J	K	TE	ADD STROKE	
								LB	P
8	8 1/2	3/4	5/8	2	1 1/2	9/16	7.57	5 1/8	3 1/4
10	10 5/8	1	3/4	2 1/4	2	1 1/16	9.40	6 3/8	4 1/8
12	12 3/4	1	3/4	2 1/4	2	1 1/16	11.10	6 7/8	4 5/8
14	14 3/4	1 1/4	7/8	2 3/4	2 1/4	1 3/16	12.87	8 1/8	5 1/2

*Mounting holes are 1/16" larger than screw size shown.

ROD END DIMENSIONS

ENVELOPE AND
MOUNTING
DIMENSIONS

BORE	ROD DIA. MM	THREAD SIZE		ROD EXTENSIONS AND PILOT DIMENSIONS								ADD STROKE			
		KK	FF	A	+000 -002 B	C	D	NA	FA	RD	VB	WF	Y	ZB	ZJ
8	1 3/8	1-14	1 1/4-12	1 5/8	1.999	5/8	1 1/8	1 5/16	5/8	3 1/4	1	1 5/8	2 13/16	7 5/16	6 3/4
	5 1/2	4-12	5 1/4-12	5 1/2	6.249	1	4 5/8	5 3/8	3/4	8	1 1/4	2 1/4	3 1/16	7 15/16	7 3/8
	1 3/4	1 1/4-12	1 1/2-12	2	2.374	3/4	1 1/2	1 11/16	5/8	3 3/4	1 1/8	1 7/8	3 1/16	7 9/16	7
	2	1 1/2-12	1 3/4-12	2 1/4	2.624	7/8	1 11/16	1 15/16	5/8	4 1/8	1 1/8	2	3 3/16	7 11/16	7 1/8
	2 1/2	1 7/8-12	2 1/4-12	3	3.124	1	2 1/16	2 3/8	5/8	4 1/2	1 1/4	2 1/4	3 1/16	7 15/16	7 3/8
	3	2 1/4-12	2 3/4-12	3 1/2	3.749	1	2 5/8	2 7/8	5/8	5 1/4	1 1/4	2 1/4	3 1/16	7 15/16	7 3/8
	3 1/2	2 1/2-12	3 1/4-12	3 1/2	4.249	1	3	3 3/8	5/8	5 1/2	1 1/4	2 1/4	3 1/16	7 15/16	7 3/8
	4	3-12	3 3/4-12	4	4.749	1	3 3/8	3 7/8	3/4	6	1 1/4	2 1/4	3 1/16	7 15/16	7 3/8
	4 1/2	3 1/4-12	4 1/4-12	4 1/2	5.249	1	3 3/8	4 3/8	3/4	6 7/8	1 1/4	2 1/4	3 1/16	7 15/16	7 3/8
10	1 3/4	1 1/4-12	1 1/2-12	2	2.374	3/4	1 1/2	1 11/16	5/8	3 3/4	1 1/8	1 7/8	3 1/8	8 15/16	8 1/4
	5 1/2	4-12	5 1/4-12	5 1/2	6.249	1	4 5/8	5 3/8	3/4	8	1 1/4	2 1/4	3 1/2	9 5/16	8 5/8
	2	1 1/2-12	1 3/4-12	2 1/4	2.624	7/8	1 11/16	1 15/16	5/8	4 1/8	1 1/8	2	3 1/4	9 1/16	8 3/8
	2 1/2	1 7/8-12	2 1/4-12	3	3.124	1	2 1/16	2 3/8	5/8	4 1/2	1 1/4	2 1/4	3 1/2	9 5/16	8 5/8
	3	2 1/4-12	2 3/4-12	3 1/2	3.749	1	2 5/8	2 7/8	5/8	5 1/4	1 1/4	2 1/4	3 1/2	9 5/16	8 5/8
	3 1/2	2 1/2-12	3 1/4-12	3 1/2	4.249	1	3	3 3/8	5/8	5 1/2	1 1/4	2 1/4	3 1/2	9 5/16	8 5/8
	4	3-12	3 3/4-12	4	4.749	1	3 3/8	3 7/8	3/4	6	1 1/4	2 1/4	3 1/2	9 5/16	8 5/8
	4 1/2	3 1/4-12	4 1/4-12	4 1/2	5.249	1	3 3/8	4 3/8	3/4	6 7/8	1 1/4	2 1/4	3 1/2	9 5/16	8 5/8
12	2	1 1/2-12	1 3/4-12	2 1/4	2.624	7/8	1 11/16	1 15/16	5/8	4 1/8	1 1/8	2	3 1/4	9 9/16	8 7/8
	5 1/2	4-12	5 1/4-12	5 1/2	6.249	1	4 5/8	5 3/8	3/4	8	1 1/4	2 1/4	3 1/2	9 13/16	9 1/8
	2 1/2	1 7/8-12	2 1/4-12	3	3.124	1	2 1/16	2 3/8	5/8	4 1/2	1 1/4	2 1/4	3 1/2	9 13/16	9 1/8
	3	2 1/4-12	2 3/4-12	3 1/2	3.749	1	2 5/8	2 7/8	5/8	5 1/4	1 1/4	2 1/4	3 1/2	9 13/16	9 1/8
	3 1/2	2 1/2-12	3 1/4-12	3 1/2	4.249	1	3	3 3/8	5/8	5 1/2	1 1/4	2 1/4	3 1/2	9 13/16	9 1/8
	4	3-12	3 3/4-12	4	4.749	1	3 3/8	3 7/8	3/4	6	1 1/4	2 1/4	3 1/2	9 13/16	9 1/8
	4 1/2	3 1/4-12	4 1/4-12	4 1/2	5.249	1	3 3/8	4 3/8	3/4	6 7/8	1 1/4	2 1/4	3 1/2	9 13/16	9 1/8
14	2 1/2	1 7/8-12	2 1/4-12	3	3.124	1	2 1/16	2 3/8	5/8	4 1/2	1 1/4	2 1/4	3 13/16	11 3/16	10 3/8
	5 1/2	4-12	5 1/4-12	5 1/2	6.249	1	4 5/8	5 3/8	3/4	8	1 1/4	2 1/4	3 13/16	11 3/16	10 3/8
	3	2 1/4-12	2 3/4-12	3 1/2	3.749	1	2 5/8	2 7/8	5/8	5 1/4	1 1/4	2 1/4	3 13/16	11 3/16	10 3/8
	3 1/2	2 1/2-12	3 1/4-12	3 1/2	4.249	1	3	3 3/8	5/8	5 1/2	1 1/4	2 1/4	3 13/16	11 3/16	10 3/8
	4	3-12	3 3/4-12	4	4.749	1	3 3/8	3 7/8	3/4	6	1 1/4	2 1/4	3 13/16	11 3/16	10 3/8
	4 1/2	3 1/4-12	4 1/4-12	4 1/2	5.249	1	3 3/8	4 3/8	3/4	6 7/8	1 1/4	2 1/4	3 13/16	11 3/16	10 3/8

Series 7L Hydraulic Cylinder Features

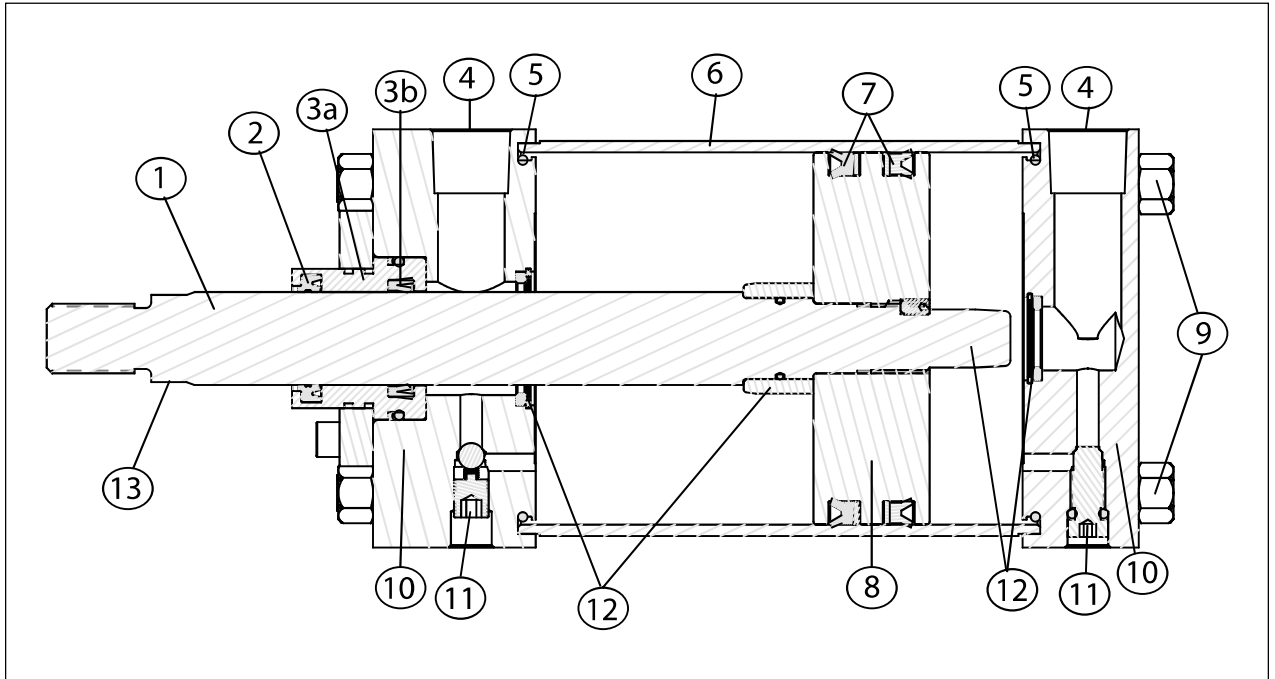

Series 7L Section 4

1. Piston Rods — $\frac{5}{8}$ " thru 4" diameter are medium carbon steel with 100,000 psi minimum yield. Piston rods over 4" diameter have yield strengths between 50,000 and 90,000 psi. Sizes $\frac{5}{8}$ " thru $3\frac{1}{2}$ " diameter are induction case hardened to 54 Rockwell C. All piston rods are hard-chrome plated and highly polished.

2. Rod Wiper —Polyurethane, double lip type wiper designed to protect the piston rod, bearing and rod seal, is standard for all rod sizes. Also, metallic scrapers and Viton wipers are available for all rod sizes.

3. Bolted Rod Gland Cartridge —Heavy wall, ductile iron bearing is accurately piloted in head to assure perfect alignment, designed to accept a variety of seal styles. With certain exceptions, the cartridges can be removed without removing mounts or tie rod nuts. This eliminates the necessity of cylinder disassembly to replace the rod seals or rod bearing. Bearings are held in place with bolted steel retainer plates. Bearings used for a given rod size are interchangeable into any cylinder bore with the same rod diameter (except for bearings used with $1\frac{1}{2}$ ", 2" and $2\frac{1}{2}$ " bores with maximum rod sizes).

a. Rod Seal —Polyurethane compound, flexible lip type rod seal has excellent abrasion resistance and is wear compensating. Inherent characteristics of the material and design assure leakproof performance and long life.

b. Rod Bearing —Ductile iron material insures low friction, high load capabilities and long life.

4. Ports —Large unrestricted ports permit maximum flow with minimum pressure drop. Heads may be rotated independently at 90° intervals for convenient port location.

5. Tube Seals —Positive sealing, synthetic rubber "O" rings seal tube I.D.

6. Tube —Steel tubing is used on $1\frac{1}{2}$ " thru 14" bore. It is microhoned and chrome plated to assure smooth operation with minimum friction. Other tubing materials are also available. Tubing is standard for 10" thru 14" bore sizes. Other tubing materials are also available.

7. Piston Seals —Flexible lip type piston seals with non-extrusion rings provide positive sealing, low friction and long life.

8. Piston —High grade alloy iron, $1\frac{1}{2}$ " thru 8" bores, also in 14" bore; steel piston for 10" thru 14" bore sizes. Pistons are one piece, pilot fitted to piston rod and locked.

9. Tie Rods and Nuts —Tie rods are made from 100,000 psi minimum yield, medium carbon steel. They are pre-stressed at assembly with hi-strength alloy hex nuts to minimize the possibility of tie rod elongation.

10. Heads and Caps —Rolled steel accurately machined to assure perfect alignment of piston rod bearing, piston rod, piston, and tube. Heads and caps pilot

on tube O.D. to prevent "breathing" and provide additional insurance against leakage.

11. Needle valves and check valves — Flush type needle valves and check valves are supplied. Large drilled passages provide maximum control of cushioning effect and assure rapid full power starts at beginning of stroke. Needle valves begin to leak prior to disengagement to prevent valve blow out. Ball checks are permanently retained.

12. Cushions —Self-aligning, synthetic rubber type seals provide a positive leak-proof cushion. This, together with adjustable cushion needle valve, offers an extremely accurate means of obtaining most efficient cushion characteristics for a variety of loads and speeds.

13. Wrench Flats —Large wrench flats are chamfered to protect rod gland packing in installation. All standard piston rods through $5\frac{1}{2}$ " diameter are furnished with two wrench flats. Additional flats are available upon request.

Mounts —All mounts are of steel plate fabricated steel, accurately machined for precise mounting.

JIC —These cylinders are designed to conform to JIC standards.

NFPA —The dimensioning and identification of the cylinders in this catalog are in accordance with the NFPA recommended dimension code for fluid power cylinders.