



aerospace
climate control
electromechanical
filtration
fluid & gas handling
hydraulics
pneumatics
process control
sealing & shielding



Heavy Duty Hydraulic Roundline Cylinders

Series RDH

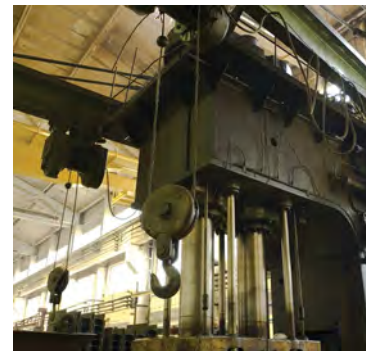

ENGINEERING YOUR SUCCESS.

In line with our policy of continuing product improvement, specifications and information contained in this catalog are subject to change.

Copyright ©2011-2014 by Parker Hannifin Corporation.
All rights reserved.

PRINTED IN THE U.S.A.

 **WARNING**

FAILURE OR IMPROPER SELECTION OR IMPROPER USE OF THE PRODUCTS AND/OR SYSTEMS DESCRIBED HEREIN OR RELATED ITEMS CAN CAUSE DEATH, PERSONAL INJURY AND PROPERTY DAMAGE.

This document and other information from the Parker Hannifin Corporation, its subsidiaries and authorized distributors provide product and/or system options for further investigation by users having expertise. It is important that you analyze all aspects of your application, including consequences of any failure and review the information concerning the product or system in the current product catalog. Due to the variety of operating conditions and applications for these products or systems, the user, through its own analysis and testing, is solely responsible for making the final selection of the products and systems and assuring that all performance, safety and warning requirements of the application are met.

The products described herein, including without limitation, product features, specifications, designs, availability and pricing, are subject to change by Parker Hannifin Corporation and its subsidiaries at any time without notice.

Offer of Sale

The items described in this document are hereby offered for sale by Parker Hannifin Corporation, its subsidiaries or its authorized distributors. This offer and its acceptance are governed by provisions stated on a separate page of the document entitled 'Offer of Sale'.

***Atlas. Our name implies strength.
And that's exactly what you'll find
throughout our entire product line.***



Atlas Cylinders are renowned for their legendary performance, durability and affordability. That's why you'll find Atlas Cylinders in use all over the world.

Here is a short list of what you can expect from Atlas Cylinders:

- Design and Application Experience
- Responsiveness
- Fast Product Delivery
- System Integration Capabilities
- Ingenuity and Creativity
- Organizational Integrity
- Highest Quality
- Competitive Pricing
- Financial Stability
- Worldwide Support



Markets and Applications

Atlas Cylinders are utilized worldwide in many markets and applications, including:

- Oil and Gas
- Renewable Energy
- Power Generation
- Process Valves
- Mining
- Primary Metals
- Metal Fabrication
- Marine
- Civil Engineering Projects (including US Army Corps of Engineers Projects)
- Military and Commercial Aerospace
- Material Handling
- Testing and Analysis
- Construction
- Wood Processing
- Waste Processing
- Automotive
- Tire Press
- Machine Tools
- Entertainment

Atlas Cylinders Series RDH Cylinders

Advanced Sealing Technology

All components are manufactured and designed for high performance, long service life, low friction and zero leakage.

- **Tri-lip rod seal** (3 sealing edges!) and bi-directional piston seal feature proven leak-free performance.
- **Durable polyurethane** material is used to maximize seal life.
- **Nitrile end seals** and backup rings on a smooth bore of the cylinder body for optimal sealing and elimination of extrusion problems.
- **Composite rod and piston wear rings** are internally lubricated for reduced friction and formulated for heavy-duty, load-bearing applications.
- **Standard rod material is case-hardened, hard chrome plated and polished** to an optimum finish.
- And since we make our own seals, **all seals have immediate availability** in other popular compounds.

Switch-Ready

- **The ALS Switch is the lowest cost point feedback solution** for carbon steel cylinders with a piston magnet ring.
- **Switches can be located anywhere along the stroke** and in any orientation.
- **Unique round body brackets** minimize installation time.
- **EPS & CLS threaded switches** are available for end-of-stroke sensing.

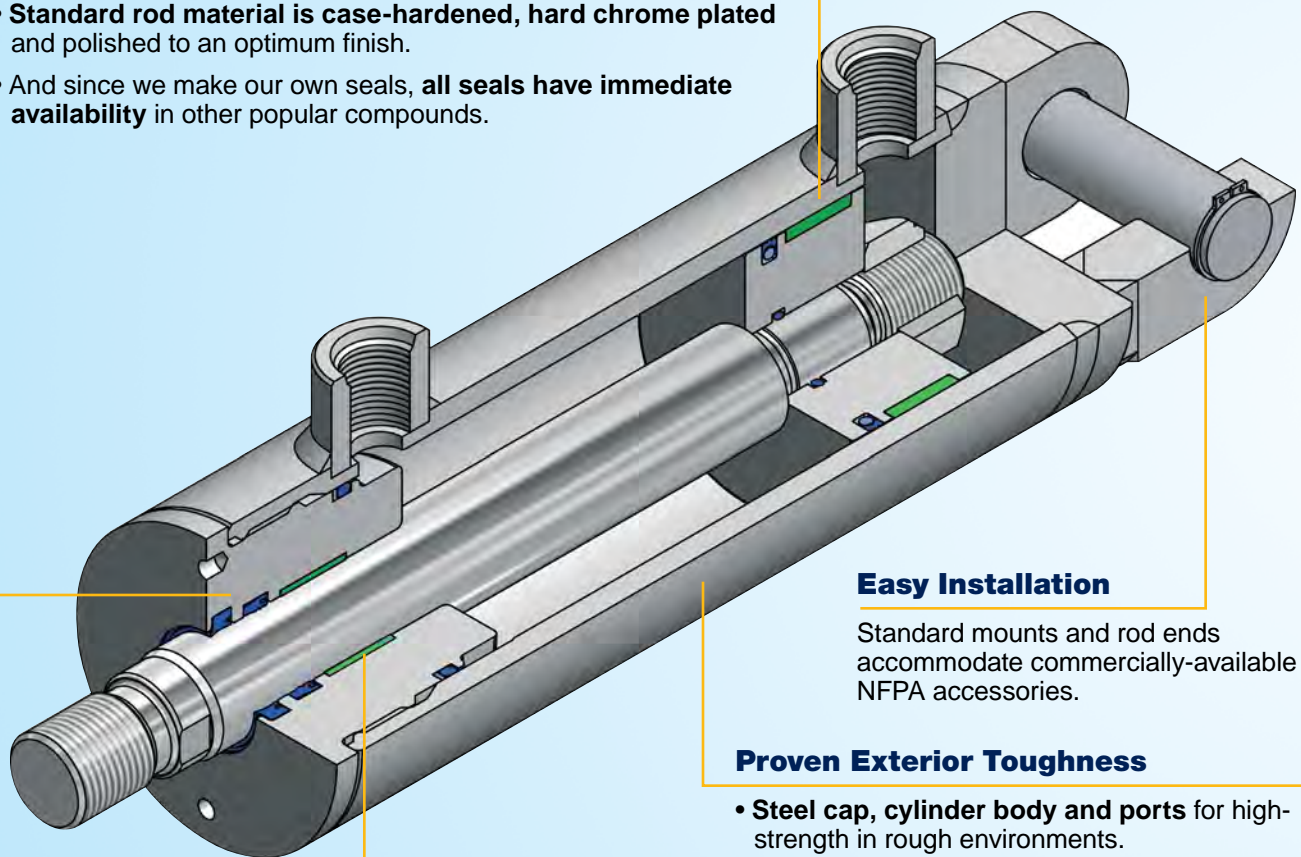

Composite Wear Rings

WearGard™ bearing materials are backed by over 30 years of manufacturing expertise.

- Heat stabilized and internally lubricated for **low friction and maximum service life** in any application.
- Strength characteristics meet or exceed most metals traditionally used in wear rings.

Easy Installation

Standard mounts and rod ends accommodate commercially-available NFPA accessories.

Proven Exterior Toughness

- **Steel cap, cylinder body and ports** for high-strength in rough environments.
- **Case hardened, hard chrome plated** and polished carbon steel piston rod for damage resistance, long rod seal life and low friction.
- **Outboard urethane rod wiper seal** to remove external debris and adherents from the piston rod.
- **High quality paint coating** for interior or exterior applications.



Environmentally Friendly
RoHS-compliant materials

New Value from a Standard Platform

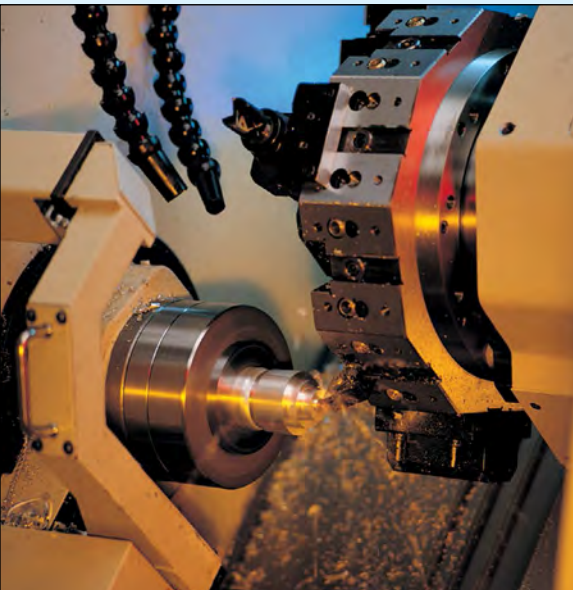

Advanced Manufacturing

Cylinders, by nature, are customized products. Whether it is something basic, such as stroke length, or something more complex, such as a special head, raw material and basic parts must be procured and manufactured into components for configured cylinders.

Organizing cylinder production and assembly requires some degree of planning. To do so, without sacrificing customer service, requires a sharp focus on advanced manufacturing processes.

Lean Manufacturing Principles

Atlas Cylinders has utilized Lean Manufacturing techniques for many years, even before it was called by name. Cellular Manufacturing, Value Stream Mapping, Kaizen events, Kanban, One-Piece Flow and other influences are pervasive in our manufacturing processes.

We now follow Lean Implementation to focus all aspects of our operation on the same goals for customer service.

Made in U.S.A.

Series RDH cylinders are manufactured in the USA. Location is a significant part of our customer service model. We believe that customers value a domestic presence, for many reasons. A few include:

- **Quick Delivery** – standard lead time is a few days, with the capability of shipping some cylinder configurations within 48 hours. We deliver to your request.
- **Made-To-Order** – we are able to quickly manufacture customized products without the need to carry fixed finished goods inventory. This minimizes time-to-customer and cost-to-customer concerns.

- **Late-Day Orders** – our West Coast presence can create an order time advantage of up to three hours for many US locations, which may be instrumental in keeping you on schedule.
- **Risk Management** – the absence of international risks from dealing with non-domestic cylinder suppliers will allow you to relax. Our goal is to offer you the best product, on time, with your financial concerns in mind.

- **Non-Standard Designs** – since 50% of applications require cylinders that are not catalog-standard, we organized our entire culture for flexibility. Our manufacturing processes are prepared to accommodate non-standard designs with minimal lead-time adjustments.

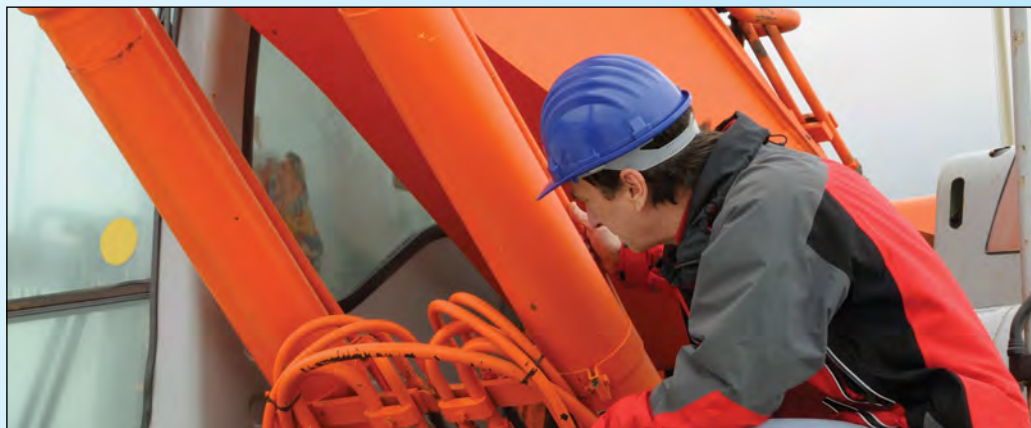

Customer Service Locations



Atlanta, GA



Enfield, CT



Corona, CA



Plymouth, MI



Goodland, IN

California
 221 Helicopter Circle
 Corona, CA 92880
 Tel.: (951) 280-3800
 Fax: (951) 280-3808
 Fax: (800) 869-9886

Indiana
 Goodland Plant
 715 South Iroquois Street
 Goodland, IN 47948
 Tel.: (219) 297-3182
 Fax: (800) 328-8120

Connecticut
 80 Shaker Road
 Enfield, CT 06082
 Tel.: (860) 749-2215
 Fax: (800) 323-0105

Michigan
 900 Plymouth Road
 Plymouth, MI 48170
 Tel.: (734) 455-1700
 Fax: (734) 455-1007

Georgia
 1300 Six Flags Road
 Lithia Springs, GA 30122
 Tel.: (770) 819-3400
 Fax: (800) 437-3498

Oregon
 29289 Airport Road
 Eugene, OR 97402
 Tel.: (541) 689-9111
 Fax: (541) 688-6771
 Fax: (800) 624-7996

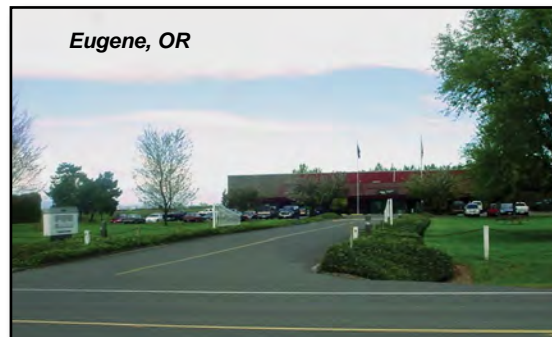

Eugene, OR

Table of Contents

<i>Description</i>	<i>Page</i>	<i>Section</i>
Section A – Basic Cylinder Information	2-20	A
Product Specifications	2	
Available Mounting Styles	3	
Custom Options and Modifications	3	
Features and Benefits	4-5	
Application Checklist	6	
Mounting Styles and Tips for Applying Them	7	
RDH Cylinder Model Code / How to Order	8-9	
Rod End Styles and Dimensions	10	
Mounting Information for Single Rod Cylinders	11-19	
Mounting Information for Double Rod Cylinders	20	
Section B – Cylinder Accessories and Replacement Parts	21-30	B
Cylinder Mounting Accessories	21-24	
Spherical Bearing Mounting Accessories	25-26	
Linear Alignment Couplers	27	
Style 55 Piston Rod End Accessories	28	
Parts Identification / Torque Tool Specifications	29	
Piston and Rod Seal Kits	30	
Section C – Common Modifications	31-57	C
Water Submersible Option	31-32	
Hi Load Piston	33	
Low Friction Seals	34-35	
Other Common Modifications	36	
ALS Switch	37-40	
EPS-A Proximity Sensor / CLS-A Limit Switches	41-43	
Cylinders with Limit Switches – Dimensions	44-52	
Counterbalance Valves	54-57	
Section D – Engineering Data	60-72	D
Theoretical Push and Pull Forces	60	
Cylinder Weights	61	
Seal Information	62-63	
Ports	64-65	
Stroke Data and Tolerances / Fatigue Life	66	
Mounting Groups and Force Transfer	66	
Stop Tubing	67	
Piston Rod Selection Data	68-69	
Cylinder Safety Guide	70-71	
Offer of Sale	72	

General Specifications

- Heavy duty service
- Standard construction – threaded head, welded cap
- Bore diameters – 1.50" through 8.00"
- Strokes – available in any practical stroke length
- Piston rod diameters – 0.625" through 5.500"
(based on bore size)
- Rod end styles – 5 standard, specials available
- Single rod end or double rod ends

In line with our policy of continuing product improvement, specifications in this catalog are subject to change.

- Mounting styles – 9 standard styles at various application ratings
- Nominal pressure – 3,000 psi¹ (207 Bar)
- Standard fluid media – filtered hydraulic oil²
- Standard temperature – -10°F to +165°F³
- RoHS compliant

¹ If hydraulic pressure exceeds 3,000 psi (207 Bar), send application data for engineering evaluation and recommendation.

² See Seal Information pages for appropriate seals with different fluid media.

³ See Seal Information pages for lower and higher temperature service.

Material Specifications – Standard Temperatures and Applications

Head	Ductile iron	Piston	Ductile iron
Cap	Carbon steel	Piston seal	Polyurethane
Cylinder body	Carbon steel	Piston seal energizer	Nitrile
Piston rod	Case-hardened, chrome plated high strength carbon steel	Piston bearing	WearGard™ or MolyGard™
Rod seal	Polyurethane	Piston fastener	Carbon steel
Rod wiper seal	Urethane	Piston joint o-ring	Fluorocarbon
Rod bearing	WearGard™	End seal o-ring	Nitrile
		Backup ring	Nitrile

Operating Temperature Options – Material and Part Changes

High temperatures (to +250°F) Class 5	Rod seal, rod wiper seal, end seal, backup ring and piston seal energizer are fluorocarbon. Piston seal is bronze filled PTFE.	Low temperatures (to -50°F) Class 4	Piston seal energizer, end seal and backup ring are low temperature rated nitrile.
Extreme high temperatures (to +400°F) Class 8	Rod seals, rod wiper seal and piston seal are bronze filled PTFE. End seal o-ring, backup ring and seal energizers are fluorocarbon. Bearings are UltraComp™ CGT.		

Other Standard Options – Material and Part Changes

Cylinder seal options ⁴ (for chemical compatibility)	Water Base Fluid Seals (Class 2) EPR Seals (Class 3) Fluorocarbon Seals (Class 5) HWCF Seals (Class 6) Mixed-Media Piston Seals (bronze filled PTFE and nitrile)	Magnetic ring	Sintered NdFeB
		Piston rod material options	17-4 PH stainless steel, chrome plated 303 and 316 stainless steel are available at lower operating pressures; consult factory.

⁴ See Seal Information pages for additional specifications.

Private Labeling

For those discerning customers wanting a personal touch, we can “private label” cylinders at no charge. The information must be in text format (no logos) and the label must include our serial number and cylinder pressure rating. Just place an “S” for special in the Special Modification field and provide the private label information in the item notes. We take care of the rest!

If labels with logos are desired, contact the Industrial Cylinder Division for assistance.

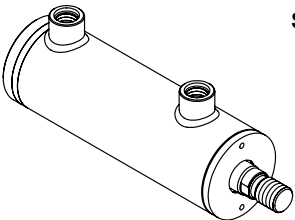
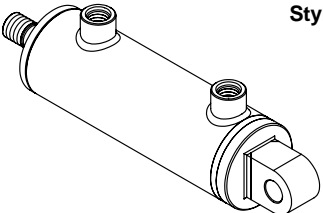
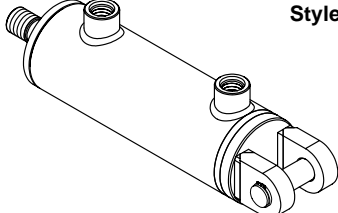
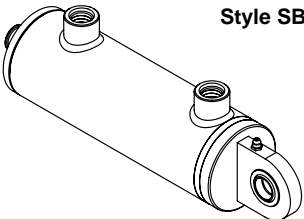
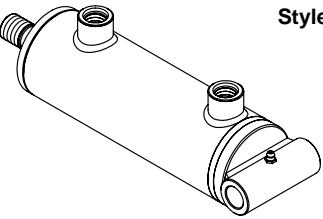
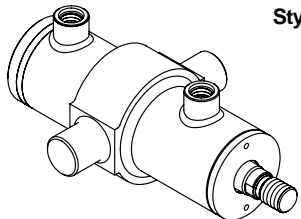
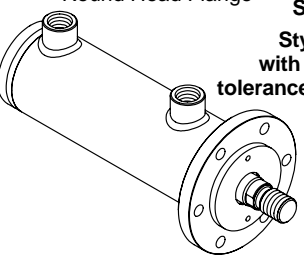
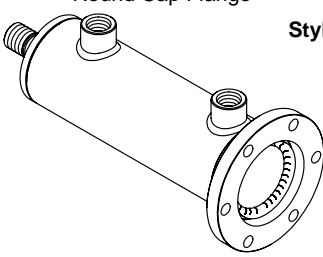
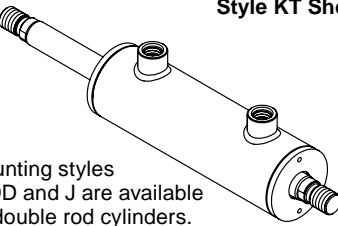

Available Mounting Styles

<p>Basic, No Mount Style T</p> 	<p>Cap Fixed Eye Style B</p> 	<p>Cap Fixed Clevis Style BB</p> 
<p>Spherical Bearing Cap End Style SB/SBM</p> 	<p>Crosstube Cap End Style TT</p> 	<p>Intermediate Fixed Trunnion Style DD</p> 
<p>Round Head Flange Style J Style JP with close tolerance pilot</p> 	<p>Round Cap Flange Style H</p> 	<p>Double Rod Cylinders Style KT Shown</p>  <p>Mounting styles T, DD and J are available as double rod cylinders.</p>



Custom Options and Modifications (consult factory)

- Special Heads, Caps, Pistons and Mounts
- Mount/Port Relocation
- Oversize/Undersize Ports
- Port Thread Styles
- Port Blocks/Valve Manifold and Flow Tubing (at either end)
- Multiple Ports
- Cartridge Valves
- Air Bleeds
- Double Rod End
- Oversize/Undersize Rod Diameters
- Extra Thick Chrome Plated Piston Rod
- Rod Materials (stainless steels, alloy steels, etc.)
- Rod Coatings (laser-clad, nanoplating, etc.)
- Nitrided Rod
- Pinned Rod to Piston
- Welded Rod to Piston
- Welded Rod End Accessory
- Extra Wrench Flats
- Rod Boot
- Crown™ Wiper (Extreme Duty Non-Metallic Rod Wiper)
- Metallic Rod Wiper
- Seal Materials (additional compounds)
- PolyPak Seals
- Stop Tube
- Stroke Adjuster
- Point Feedback – ALS Switch (PNP/NPN Mid-Stroke Switch)
- Point Feedback – CLS-A Switch (Magnetically-Actuated End-Of-Stroke Limit Switch)
- Point Feedback – EPS-A Sensor (PNP End-Of-Stroke Proximity Sensor)
- Continuous Linear Position Feedback Linear Displacement Transducer (LDT)
- Fixed Cushions
- High Pressure Service (>3,000 PSI)
- Pneumatic Service
- Water Submersible Design
- Chrome Plated Bore
- Nickel Plated Assembly
- Application-Specific Paint (Marine-Grade, Salt-Spray Rated, Caustic Washdown, etc.)
- Stainless Steel Construction (derated operating pressure)
- Metric Rod and Bore Diameters
- Dual End Seals

The inside story on why Series RDH is your best choice in heavy duty roundline cylinders

Optional Extreme Temperature/ Low Friction Seal Assembly –

Dual bronze filled PTFE rod seals and bronze filled PTFE wiper seal are energized with fluorocarbon o-rings to maintain consistent contact with the piston rod.

The result is excellent sealing performance with low friction. Our seal set provides a “dry rod” surface on the extend stroke with rod scraping to clean the rod on the retract stroke. Heat resistance to 400°F with the Class 8 Seals option. For additional

details, see the Low Friction Seals page and Class 8 Seals specifications on the Seal Information page.

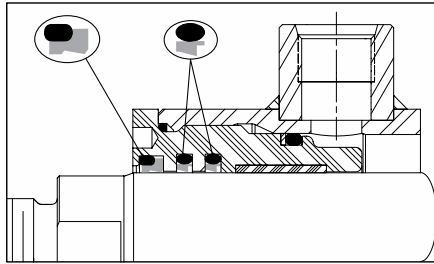

Ports – Seal-welded to the cylinder body. SAE straight thread o-ring ports are standard. Other port styles (NPTF, BSPP, BSPT, etc.) are also available.

Primary Seal – Polyurethane Tri-Lip Rod Seal is a proven leakproof design – completely self-compensating and self-relieving to withstand variations and conform to mechanical deflection that may occur.

Secondary Seal – Dual-Service Urethane Wiperseal™ – wipes clean any oil film adhering to the rod on the extend stroke and removes external debris and adherents from the rod on the return stroke.

Piston Rod – Induction case-hardened, hard chrome-plated medium carbon steel, polished to an optimum finish. Piston rods are made from 100,000 psi minimum yield material for .625" through 4.000" diameters and 70,000 psi minimum yield material for larger diameters. Stainless steel is available as an option.

Ductile Iron Head – Concentric with the bore, it acts as the high-strength rod guide and housing for the rod seal, wiper seal and bearing. Torqued to the cylinder body for lasting cylinder integrity.

End Seal – O-ring with backup ring located on a smooth bore to combine leak-free service with an anti-extrusion design.

Composite Wear Rings – WearGard™ wear rings are internally lubricated for reduced friction and formulated for heavy-duty, load-bearing applications.

Buttress Threads – The strongest commercial thread style for pressure vessels with axial and impact loading.

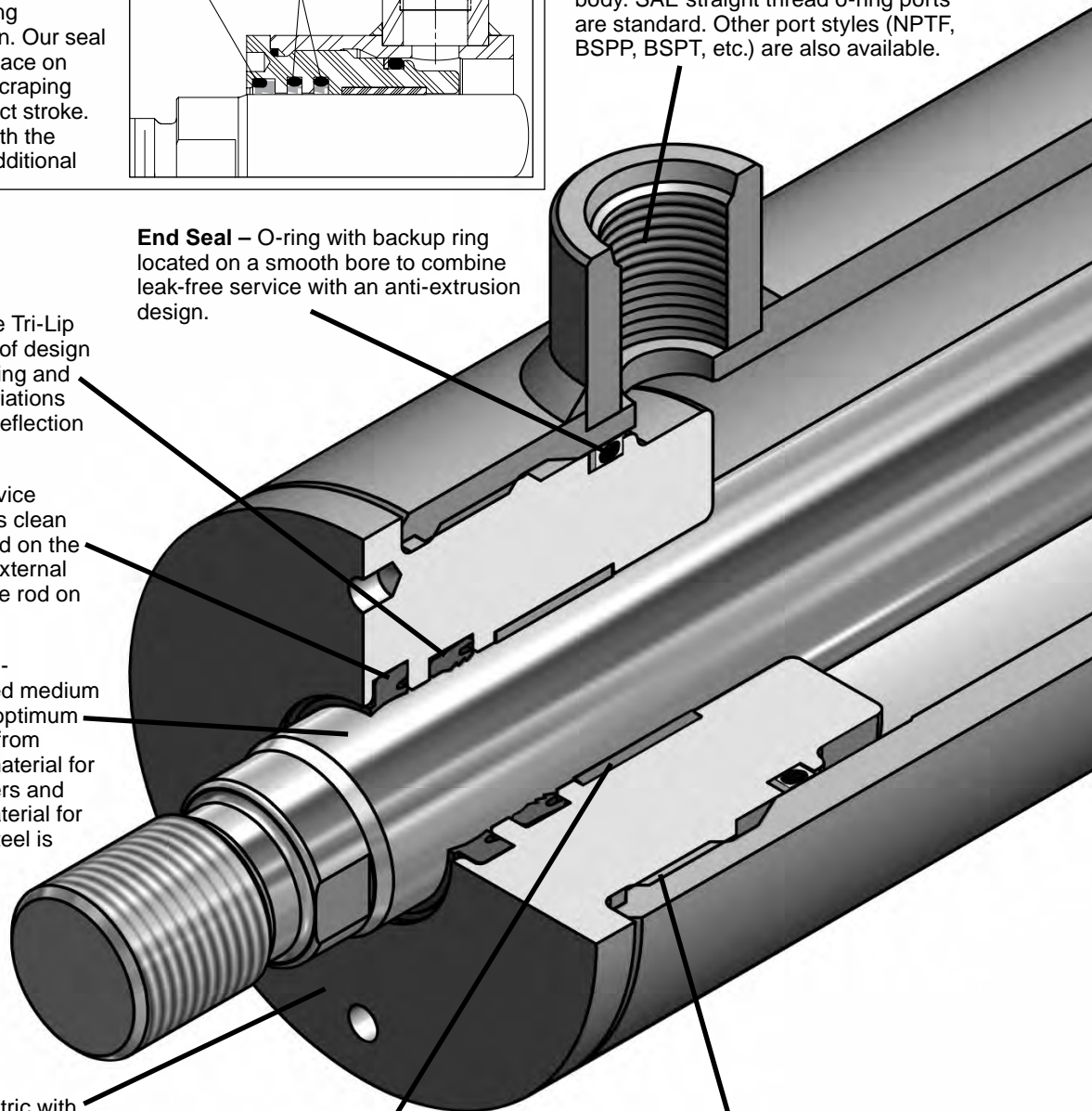

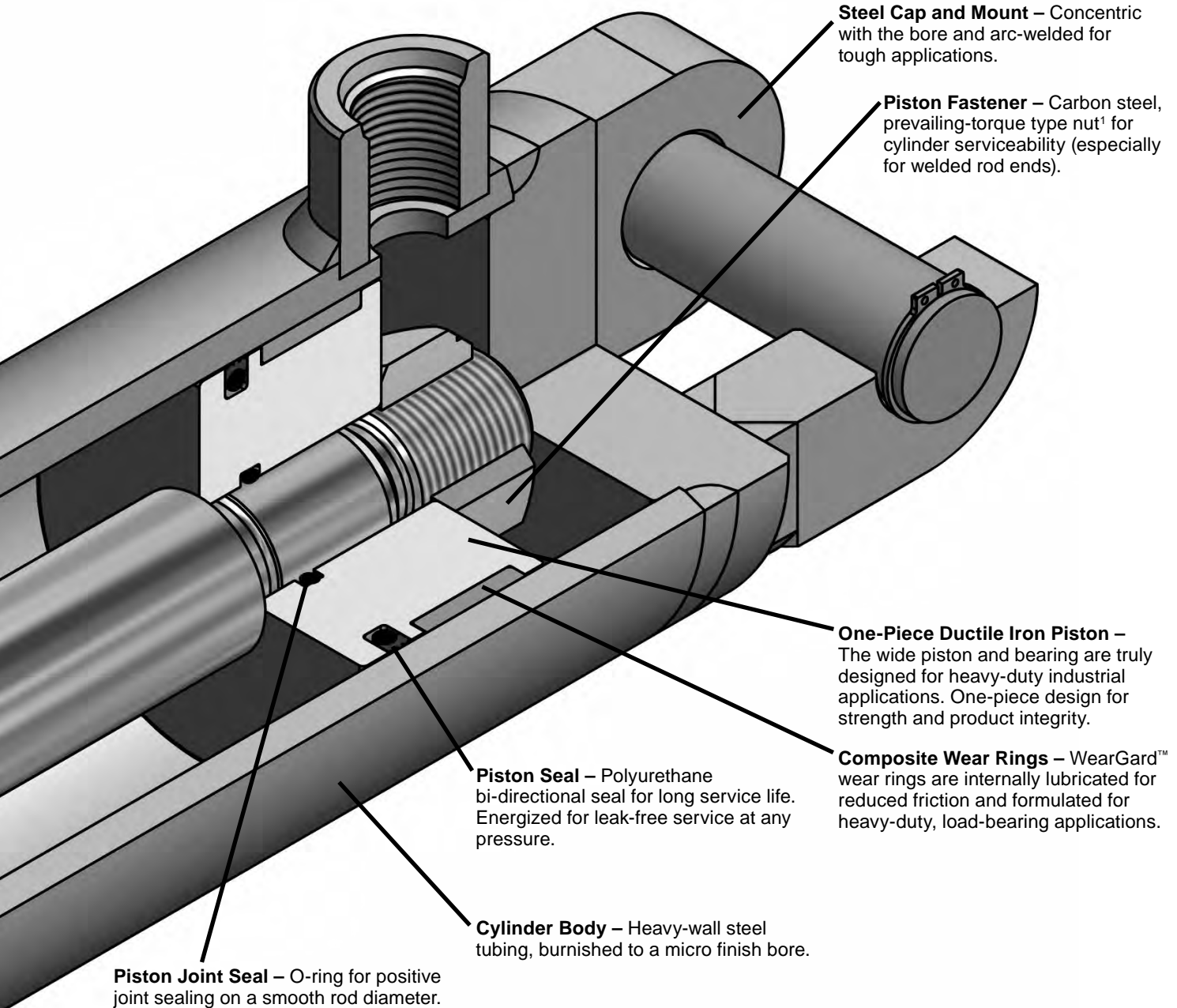

Steel Cap and Mount – Concentric with the bore and arc-welded for tough applications.

Piston Fastener – Carbon steel, prevailing-torque type nut¹ for cylinder serviceability (especially for welded rod ends).

One-Piece Ductile Iron Piston – The wide piston and bearing are truly designed for heavy-duty industrial applications. One-piece design for strength and product integrity.

Composite Wear Rings – WearGard™ wear rings are internally lubricated for reduced friction and formulated for heavy-duty, load-bearing applications.

Piston Seal – Polyurethane bi-directional seal for long service life. Energized for leak-free service at any pressure.

Cylinder Body – Heavy-wall steel tubing, burnished to a micro finish bore.

Piston Joint Seal – O-ring for positive joint sealing on a smooth rod diameter.

¹ Only for 1.50" to 5.00" bores. For 6.00" to 8.00" bores, pistons are threaded and torqued to the piston rod, and set screws are used to lock the piston to the rod.

Optional Pistons

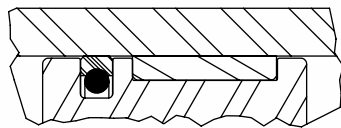

Hi Load/Low Friction Piston – Bronze filled PTFE piston seal for maximum seal life in extreme duty and side load applications.

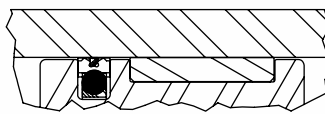

Mixed Media Piston – Used for dissimilar fluids or a gas on either side of the piston (i.e. air/oil applications).

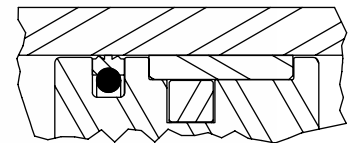

Magnetic Piston – Includes magnetic rings for the ALS Switch option.

Application Checklist

The following checklist should be used to select the best possible cylinder for a given application. Additional information can be referenced in the following pages to help assist in this process. In the event that you have additional questions or concerns, or if more information is required, contact your local distributor or our customer service representatives for assistance.

1. Establish the system requirements

- How heavy is the load to be moved?
- What is the nominal operating pressure of the system?
- How far does the load have to move?
- What is the speed at which the load will move?
- What is the fluid type and the temperature to which the cylinder will be exposed?

2. Mounting StylePages 3 and 7

- Determine the best mounting style for the application.

3. Cylinder Bore and Operating PressurePage 60

- Review the theoretical push and pull forces to determine the applicable bore and rod diameter sizes.

4. Piston Rod Pages 66-69

- Determine what rod size will be required to avoid buckling.
- Determine if a single or double rod cylinder is required.
- Determine the rod end style and rod end thread.
- Will stop tubing be required?
- Is adequate pull force still available or is a larger bore diameter now required?

5. Seals Pages 62-63

- Select the proper seal type and configuration for the application.
- Select the proper seal to assure fluid and temperature compatibility.

6. Ports Page 64-65

- Select the best possible port size for a given speed requirement.
- Select port type.
- Select port position.

7. Piston rod and mounting accessoriesPages 21-28

- Determine how you will attach the cylinder to the load.

8. Optional accessories and modificationsPages 31-57

Mounting Styles and Tips for Applying Them

Pivot Mountings – B, BB, SB/SBM and TT

Application:

- Curved or arc line force transfer
- Can be used in compression or tension loads
- Movement in a simple arc – use B, BB or TT mounts
- Movement in a compound arc – use SB/SBM mount

Advantages:

- Ease of mounting
- Design flexibility
- Self aligning (SB/SBM mount)

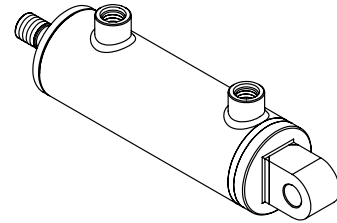

Trunnion Mountings – DD

Application:

- Curved or arc line force transfer
- Can be used in compression or tension loads

Advantages:

- Ease of mounting
- Design flexibility
- Improved cylinder weight support
- Reduces piston and rod bearing loads

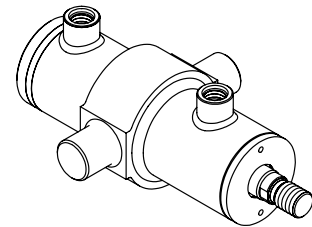

Flange Mountings – J/JP and H

Application:

- Straight line force transfer
- Compression loads (push) – use H mount
- Tension loads (pull) – use J/JP mount

Advantages:

- Ease of mounting
- Rigid base mounting due to large flange area
- JP Mount pilot improves alignment of cylinder and load

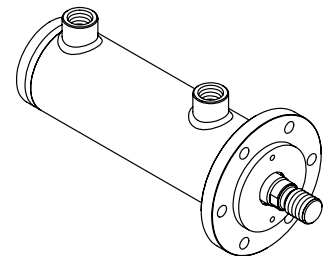

Series RDH Model Code

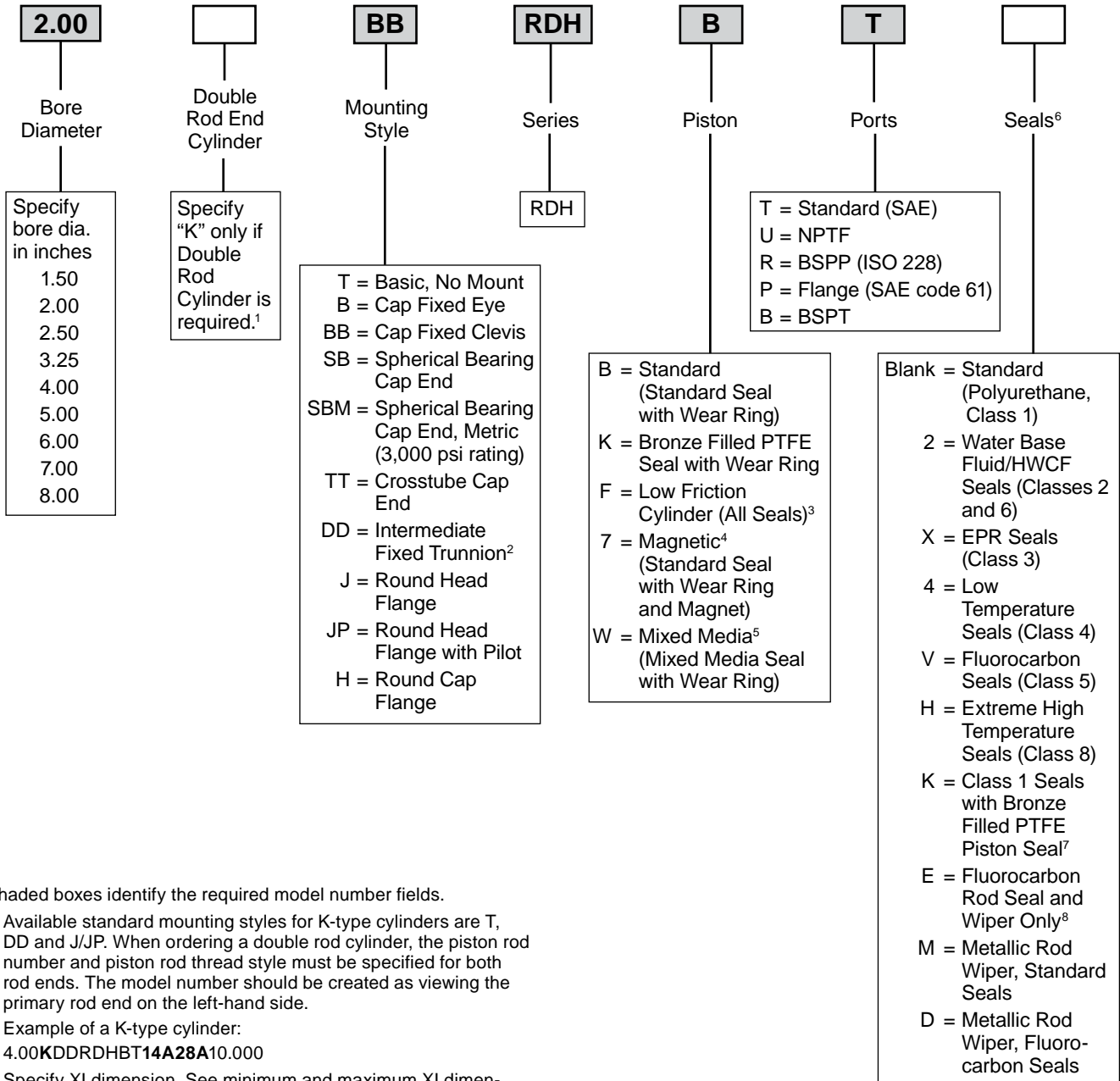

Shaded boxes identify the required model number fields.

¹ Available standard mounting styles for K-type cylinders are T, DD and J/JP. When ordering a double rod cylinder, the piston rod number and piston rod thread style must be specified for both rod ends. The model number should be created as viewing the primary rod end on the left-hand side.

Example of a K-type cylinder:
4.00KDDRDHBT14A28A10.000

² Specify XI dimension. See minimum and maximum XI dimensions on DD Intermediate Fixed Trunnion Mounting Page.

³ Includes low friction seals for the entire cylinder. Available with standard seals and Seal codes 2, X, 4, V and H.

⁴ Used with externally mounted ALS Switches. Includes seal and wear ring from standard piston. Available for 1.50" to 6.00" bore diameters. Switch operating temperature range is -13°F to +185°F. Switch position may be restricted for Mounting Style DD. Consult factory for other options.

⁵ Used for dissimilar fluids or a gas on either side of the piston (i.e. air/oil applications). Standard mixed media piston accommodates fluids which are compatible with Class 1 Seals. See Seal Information pages for more details. For other fluids, consult factory.

⁶ See Seal Information pages for additional information.

⁷ Option used for Piston code 7 (Magnetic Piston).

⁸ Used for external chemical compatibility applications, not high temperature.

Series RDH Model Code

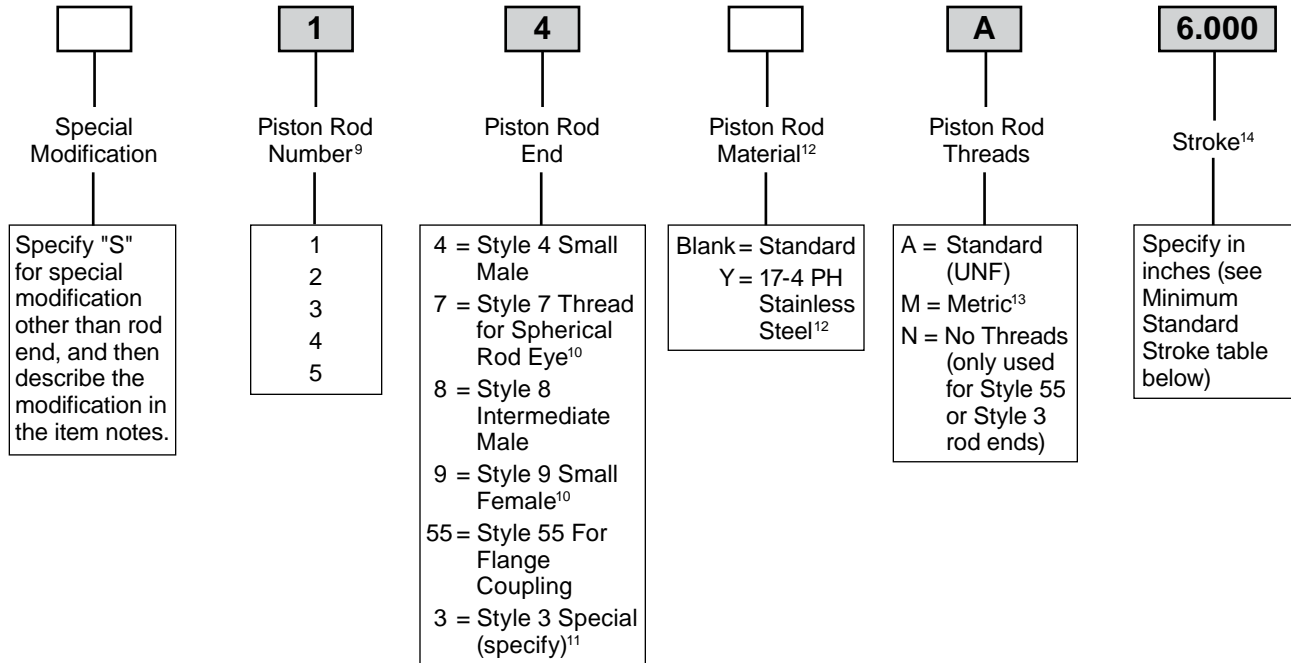

Minimum Standard Stroke

Bore Ø	Rod No.	MM Rod Ø	DD Mount	With Style 9 or 7A Rod End and Standard W Dimension	
				J Mount	All Other Mounts
1.50	1	0.625	3.03	No Min.	No Min.
	2	1.000	3.03	No Min.	No Min.
2.00	1	1.000	3.12	No Min.	No Min.
	2	1.375	3.12	No Min.	0.25
2.50	1	1.000	2.98	No Min.	No Min.
	2	1.750	2.98	No Min.	0.44
	3	1.375	2.98	No Min.	No Min.
3.25	1	1.375	3.61	No Min.	No Min.
	2	2.000	3.61	No Min.	0.65
	3	1.750	3.61	No Min.	0.19
4.00	1	1.750	3.52	No Min.	No Min.
	2	2.500	3.52	1.19	1.94
	3	2.000	3.52	No Min.	0.40
5.00	1	2.000	3.88	No Min.	0.15
	2	3.500	3.88	1.29	2.04
	3	2.500	3.88	0.43	1.18
	4	3.000	3.88	1.08	1.83
6.00	1	2.500	4.46	0.49	1.24
	2	4.000	4.46	2.26	3.01
	3	3.000	4.46	1.14	1.89
	4	3.500	4.46	1.35	2.10
7.00	1	3.000	5.10	0.95	1.95
	2	5.000	5.10	3.36	4.36
	3	3.500	5.10	1.16	2.16
	4	4.000	5.10	2.07	3.07
	5	4.500	5.10	2.65	3.65
8.00	1	3.500	5.54	0.94	1.94
	2	5.500	5.54	4.06	5.06
	3	4.000	5.54	1.86	2.86
	4	4.500	5.54	2.44	3.44
	5	5.000	5.54	3.15	4.15

Shaded boxes identify the required model number fields.

⁹ Refer to the Stop Tubing and Piston Rod Selection Data pages to assure that the selected rod number will not buckle under load.

¹⁰ Style 7A (UNF threads) and Style 9 may require a minimum stroke. See Minimum Standard Stroke in table to the left for details.

¹¹ Provide desired dimensions for KK (or CC), A and W. If otherwise special, supply a dimensioned sketch. Accessories welded to the rod end are available.

¹² Other stainless steels (i.e. 303, 316) are available with a derated maximum operating pressure; consult factory.

¹³ For Style 7M, see page 15 for details. For Styles 4M, 8M and 9M, see page 36 for details.

¹⁴ If a stop tube is required, specify **gross stroke** (net stroke + stop tube length) in the model number field, then place an "S" for special in the Special Modification field and specify the stop tube length in the item notes. For stroke length tolerance, see Stroke Data page.

Rod End Dimensions

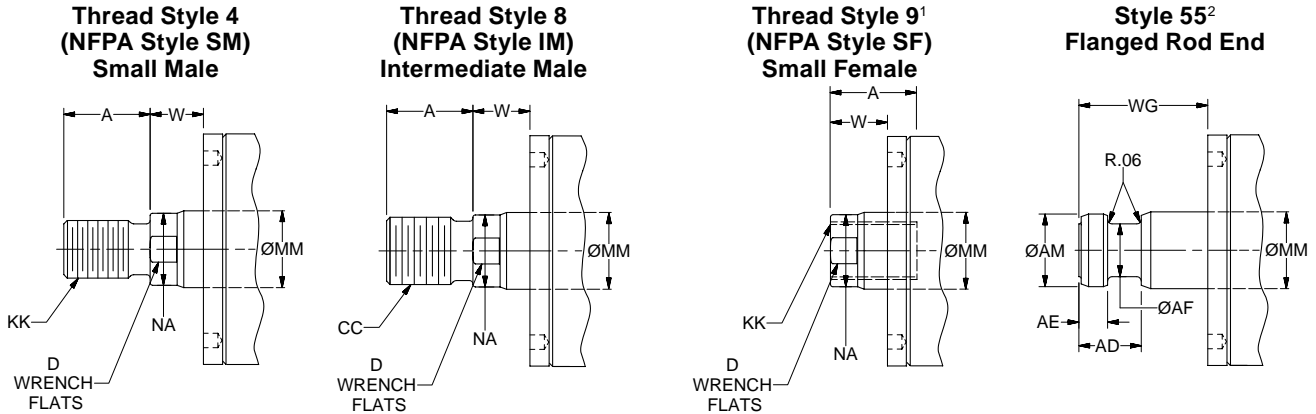

Rod End Dimensions

Bore Ø	Rod No.	MM Rod Ø	Thread		A	AD	AE +0.001 -0.001	AF Ø	AM Ø	D	NA	W	WG
			Style 8 CC	Style 4 & 9 KK									
1.50	1 (std)	0.625	1/2-20	7/16-20	0.75	0.63	0.249	0.38	0.57	0.50	0.56	0.56	1.13
	2	1.000	7/8-14	3/4-16	1.13	0.94	0.374	0.69	0.95	0.88	0.94	0.69	1.50
2.00	1 (std)	1.000	7/8-14	3/4-16	1.13	0.94	0.374	0.69	0.95	0.88	0.94	0.69	1.50
	2	1.375	1 1/4-12	1-14	1.63	1.06	0.374	0.88	1.32	1.13	1.31	0.81	1.75
2.50	1 (std)	1.000	7/8-14	3/4-16	1.13	0.94	0.374	0.69	0.95	0.88	0.94	0.69	1.50
	2	1.750	1 1/2-12	1 1/4-12	2.00	1.31	0.499	1.13	1.70	1.50	1.69	0.94	2.00
	3	1.375	1 1/4-12	1-14	1.63	1.06	0.374	0.88	1.32	1.13	1.31	0.81	1.75
3.25	1 (std)	1.375	1 1/4-12	1-14	1.63	1.06	0.374	0.88	1.32	1.13	1.31	0.81	1.75
	2	2.000	1 3/4-12	1 1/2-12	2.25	1.69	0.624	1.38	1.95	1.69	1.94	1.00	2.63
	3	1.750	1 1/2-12	1 1/4-12	2.00	1.31	0.499	1.13	1.70	1.50	1.69	0.94	2.00
4.00	1 (std)	1.750	1 1/2-12	1 1/4-12	2.00	1.31	0.499	1.13	1.70	1.50	1.69	0.94	2.00
	2	2.500	2 1/4-12	1 7/8-12	3.00	1.94	0.749	1.75	2.45	2.06	2.38	1.06	3.25
	3	2.000	1 3/4-12	1 1/2-12	2.25	1.69	0.624	1.38	1.95	1.69	1.94	1.00	2.63
5.00	1 (std)	2.000	1 3/4-12	1 1/2-12	2.25	1.69	0.624	1.38	1.95	1.69	1.94	1.00	2.63
	2	3.500	3 1/4-12	2 1/2-12	3.50	2.69	0.999	2.50	3.45	3.00	3.38	1.06	4.38
	3	2.500	2 1/4-12	1 7/8-12	3.00	1.94	0.749	1.75	2.45	2.06	2.38	1.06	3.25
	4	3.000	2 3/4-12	2 1/4-12	3.50	2.44	0.874	2.25	2.95	2.63	2.88	1.06	3.63
6.00	1 (std)	2.500	2 1/4-12	1 7/8-12	3.00	1.94	0.749	1.75	2.45	2.06	2.38	1.06	3.25
	2	4.000	3 3/4-12	3-12	4.00	2.69	0.999	3.00	3.95	3.38	3.88	1.06	4.50
	3	3.000	2 3/4-12	2 1/4-12	3.50	2.44	0.874	2.25	2.95	2.63	2.88	1.06	3.63
	4	3.500	3 1/4-12	2 1/2-12	3.50	2.69	0.999	2.50	3.45	3.00	3.38	1.06	4.38
7.00	1 (std)	3.000	2 3/4-12	2 1/4-12	3.50	2.44	0.874	2.25	2.95	2.63	2.88	1.06	3.63
	2	5.000	4 3/4-12	3 1/2-12	5.00	3.19	1.499	3.88	4.95	— ³	4.88	1.19	5.38
	3	3.500	3 1/4-12	2 1/2-12	3.50	2.69	0.999	2.50	3.45	3.00	3.38	1.06	4.38
	4	4.000	3 3/4-12	3-12	4.00	2.69	0.999	3.00	3.95	3.38	3.88	1.06	4.50
	5	4.500	4 1/4-12	3 1/4-12	4.50	3.19	1.499	3.50	4.45	— ³	4.38	1.19	5.25
8.00	1 (std)	3.500	3 1/4-12	2 1/2-12	3.50	2.69	0.999	2.50	3.45	3.00	3.38	1.06	4.38
	2	5.500	5 1/4-12	4-12	5.50	3.94	1.874	4.38	5.45	— ³	5.38	1.19	6.25
	3	4.000	3 3/4-12	3-12	4.00	2.69	0.999	3.00	3.95	3.38	3.88	1.06	4.50
	4	4.500	4 1/4-12	3 1/4-12	4.50	3.19	1.499	3.50	4.45	— ³	4.38	1.19	5.25
	5	5.000	4 3/4-12	3 1/2-12	5.00	3.19	1.499	3.88	4.95	— ³	4.88	1.19	5.38

“Special” Thread Style 3

Special thread, extension, rod eye, blank, welded rod end accessory, etc. are also available.

To order, specify “Style 3” and give desired dimensions for KK, A, W or WF. If otherwise special, furnish dimensioned sketch.

¹ Style 9 stroke restrictions may apply. See Minimum Stroke for Style 9 Rod End in table on How To Order page for details.

² For any special Style 55 dimensions, specify “Style 3” and provide the desired dimensions for AD, AE, AF, AM and WG. For other changes, specify “S” in the model code, and describe the rod end with a dimensioned sketch.

³ These piston rods have four 0.515" dia. x 0.5" deep spanner wrench holes instead of wrench flats on diameter NA.

Mounting Information – 1.50" to 8.00" Bore

Series RDH

**Basic, No Mount
Style T**

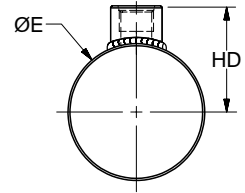
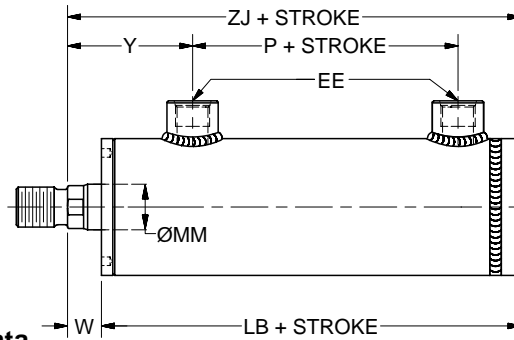
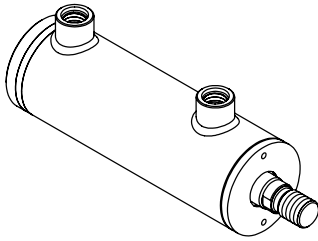

Table 1 – Dimensional and Mounting Data

Bore Ø	Rod No.	E Ø	EE		HD	Add Stroke	
			NPTF ¹	SAE ²		LB	P
1.50	1 (std)	1.88	3/8	6	1.60	3.56	1.19
	2	1.88	3/8	6	1.60	3.94	1.19
2.00	All	2.38	1/2	8	2.04	4.81	1.93
2.50	All	3.00	1/2	8	2.37	5.25	1.88
3.25	All	3.88	3/4	12	2.81	6.00	2.06
4.00	All	4.61	3/4	12	3.20	6.50	2.50
5.00	All	5.75	3/4	12	3.79	7.12	2.56
6.00	All	7.00	1	16	4.58	8.37	3.00
7.00	All	8.00	1 1/4	20	5.11	9.00	3.25
8.00	All	9.25	1 1/4	20	5.76	9.50	3.25

¹ NPTF ports are available for no additional charge ² SAE straight thread o-ring ports are standard

Table 2 – Dimensional and Mounting Data

Bore Ø	Rod No.	MM Rod Ø	W	Y	Add Stroke
					ZJ
1.50	1 (std)	0.625	0.56	2.12	4.12
	2	1.000	0.69	2.62	4.63
2.00	1 (std)	1.000	0.69	2.51	5.50
	2	1.375	0.81	2.63	5.62
2.50	1 (std)	1.000	0.69	2.69	5.94
	2	1.750	0.94	2.94	6.19
	3	1.375	0.81	2.81	6.06
3.25	1 (std)	1.375	0.81	3.06	6.81
	2	2.000	1.00	3.25	7.00
	3	1.750	0.94	3.19	6.94
4.00	1 (std)	1.750	0.94	3.40	7.44
	2	2.500	1.06	3.52	7.56
	3	2.000	1.00	3.46	7.50
5.00	1 (std)	2.000	1.00	3.70	8.12
	2	3.500	1.06	3.76	8.18
	3	2.500	1.06	3.76	8.18
	4	3.000	1.06	3.76	8.18
6.00	1 (std)	2.500	1.06	4.24	9.43
	2	4.000	1.06	4.24	9.43
	3	3.000	1.06	4.24	9.43
	4	3.500	1.06	4.24	9.43
7.00	1 (std)	3.000	1.06	4.25	10.06
	2	5.000	1.19	4.38	10.19
	3	3.500	1.06	4.25	10.06
	4	4.000	1.06	4.25	10.06
	5	4.500	1.19	4.38	10.19
8.00	1 (std)	3.500	1.06	4.44	10.56
	2	5.500	1.19	4.56	10.68
	3	4.000	1.06	4.44	10.56
	4	4.500	1.19	4.56	10.68
	5	5.000	1.19	4.56	10.68



Mounting Information – 1.50" to 8.00" Bore Series RDH

Cap Fixed Eye Mounting Style B

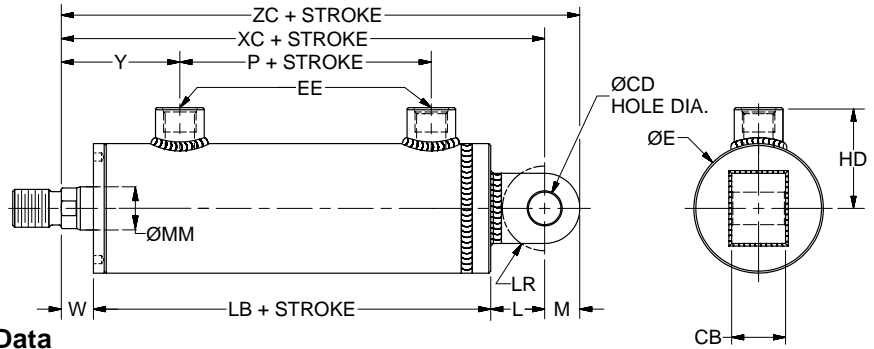
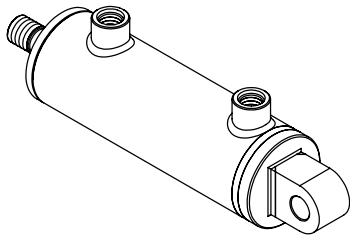

Table 1 – Dimensional and Mounting Data

Bore Ø	Rod No.	CB	CD Ø +0.002 -0.000	E Ø	EE		HD	L	LR min.	M	Add Stroke	
					NPTF ¹	SAE ²					LB	P
1.50	1 (std)	0.75	0.502	1.88	3/8	6	1.60	0.75	0.56	0.50	3.56	1.19
	2	0.75	0.502	1.88	3/8	6	1.60	0.75	0.56	0.50	3.94	1.19
2.00	All	1.25	0.752	2.38	1/2	8	2.04	1.25	0.88	0.75	4.81	1.93
2.50	All	1.25	0.752	3.00	1/2	8	2.37	1.25	0.88	0.75	5.25	1.88
3.25	All	1.50	1.002	3.88	3/4	12	2.81	1.50	1.13	1.00	6.00	2.06
4.00	All	2.00	1.377	4.61	3/4	12	3.20	2.13	1.81	1.38	6.50	2.50
5.00	All	2.50	1.752	5.75	3/4	12	3.79	2.25	1.88	1.75	7.12	2.56
6.00	All	2.50	2.002	7.00	1	16	4.58	2.50	2.13	2.00	8.37	3.00
7.00	All	3.00	2.502	8.00	1 1/4	20	5.11	3.00	2.63	2.50	9.00	3.25
8.00	All	3.00	3.002	9.25	1 1/4	20	5.76	3.25	3.00	2.75	9.50	3.25

¹ NPTF ports are available for no additional charge ² SAE straight thread o-ring ports are standard

Table 2 – Dimensional and Mounting Data

Bore Ø	Rod No.	MM Rod Ø	W	Y	Add Stroke	
					XC	ZC
1.50	1 (std)	0.625	0.56	2.12	4.87	5.37
	2	1.000	0.69	2.62	5.38	5.88
2.00	1 (std)	1.000	0.69	2.51	6.75	7.50
	2	1.375	0.81	2.63	6.87	7.62
2.50	1 (std)	1.000	0.69	2.69	7.19	7.94
	2	1.750	0.94	2.94	7.44	8.19
	3	1.375	0.81	2.81	7.31	8.06
3.25	1 (std)	1.375	0.81	3.06	8.31	9.31
	2	2.000	1.00	3.25	8.50	9.50
	3	1.750	0.94	3.19	8.44	9.44
4.00	1 (std)	1.750	0.94	3.40	9.56	10.94
	2	2.500	1.06	3.52	9.69	11.06
	3	2.000	1.00	3.46	9.62	11.00
5.00	1 (std)	2.000	1.00	3.70	10.37	12.12
	2	3.500	1.06	3.76	10.43	12.18
	3	2.500	1.06	3.76	10.43	12.18
	4	3.000	1.06	3.76	10.43	12.18
6.00	1 (std)	2.500	1.06	4.24	11.93	13.93
	2	4.000	1.06	4.24	11.93	13.93
	3	3.000	1.06	4.24	11.93	13.93
	4	3.500	1.06	4.24	11.93	13.93
7.00	1 (std)	3.000	1.06	4.25	13.06	15.56
	2	5.000	1.19	4.38	13.19	15.69
	3	3.500	1.06	4.25	13.06	15.56
	4	4.000	1.06	4.25	13.06	15.56
	5	4.500	1.19	4.38	13.09	15.69
8.00	1 (std)	3.500	1.06	4.44	13.81	16.56
	2	5.500	1.19	4.56	13.93	16.68
	3	4.000	1.06	4.44	13.81	16.56
	4	4.500	1.19	4.56	13.93	16.68
	5	5.000	1.19	4.56	13.93	16.68

Mounting Information – 1.50" to 8.00" Bore Series RDH

Cap Fixed Clevis Mounting Style BB

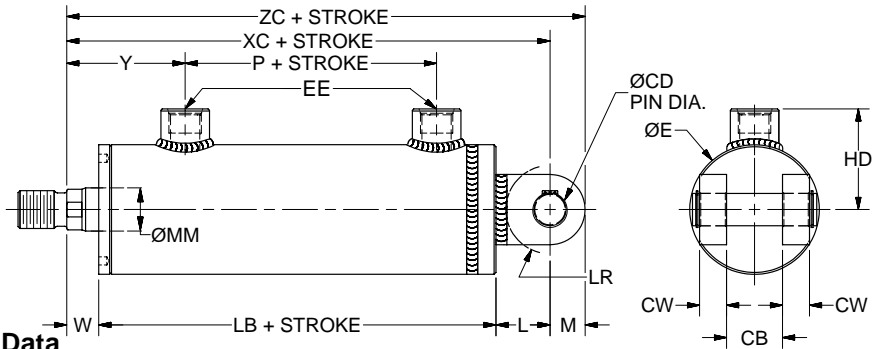
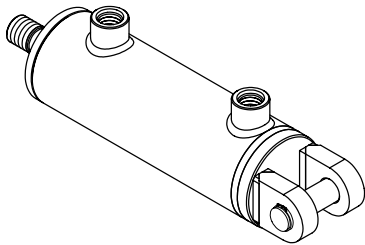

Table 1 – Dimensional and Mounting Data

Bore Ø	Rod No.	CB min.	CD ¹ Ø +.000 -.002	CW	E Ø	EE		HD	L	LR min.	M	Add Stroke	
						NPTF ²	SAE ³					LB	P
1.50	1 (std)	0.77	.501	0.50	1.88	3/8	6	1.60	0.75	0.56	0.50	3.56	1.19
	2	0.77	.501	0.50	1.88	3/8	6	1.60	0.75	0.56	0.50	3.94	1.19
2.00	All	1.09	.751	0.50	2.38	1/2	8	2.04	1.25	0.88	0.75	4.81	1.93
2.50	All	1.28	.751	0.63	3.00	1/2	8	2.37	1.25	0.88	0.75	5.25	1.88
3.25	All	1.53	1.001	0.75	3.88	3/4	12	2.81	1.50	1.13	1.00	6.00	2.06
4.00	All	2.06	1.376	1.00	4.61	3/4	12	3.20	2.13	1.81	1.38	6.50	2.50
5.00	All	2.56	1.751	1.25	5.75	3/4	12	3.79	2.25	1.88	1.75	7.12	2.56
6.00	All	2.56	2.001	1.25	7.00	1	16	4.58	2.50	2.13	2.00	8.37	3.00
7.00	All	3.06	2.501	1.50	8.00	1 1/4	20	5.11	3.00	2.63	2.50	9.00	3.25
8.00	All	3.06	3.001	1.50	9.25	1 1/4	20	5.76	3.25	3.00	2.75	9.50	3.25

¹ Diameter CD is the Pivot Pin diameter (included) ² NPTF ports are available for no additional charge

³ SAE straight thread o-ring ports are standard

Table 2 – Dimensional and Mounting Data

Bore Ø	Rod No.	MM Rod Ø	W	Y	Add Stroke	
					XC	ZC
1.50	1 (std)	0.625	0.56	2.12	4.87	5.37
	2	1.000	0.69	2.62	5.38	5.88
2.00	1 (std)	1.000	0.69	2.51	6.75	7.50
	2	1.375	0.81	2.63	6.87	7.62
2.50	1 (std)	1.000	0.69	2.69	7.19	7.94
	2	1.750	0.94	2.94	7.44	8.19
	3	1.375	0.81	2.81	7.31	8.06
3.25	1 (std)	1.375	0.81	3.06	8.31	9.31
	2	2.000	1.00	3.25	8.50	9.50
	3	1.750	0.94	3.19	8.44	9.44
4.00	1 (std)	1.750	0.94	3.40	9.56	10.94
	2	2.500	1.06	3.52	9.69	11.06
	3	2.000	1.00	3.46	9.62	11.00
5.00	1 (std)	2.000	1.00	3.70	10.37	12.12
	2	3.500	1.06	3.76	10.43	12.18
	3	2.500	1.06	3.76	10.43	12.18
	4	3.000	1.06	3.76	10.43	12.18
6.00	1 (std)	2.500	1.06	4.24	11.93	13.93
	2	4.000	1.06	4.24	11.93	13.93
	3	3.000	1.06	4.24	11.93	13.93
	4	3.500	1.06	4.24	11.93	13.93
7.00	1 (std)	3.000	1.06	4.25	13.06	15.56
	2	5.000	1.19	4.38	13.19	15.69
	3	3.500	1.06	4.25	13.06	15.56
	4	4.000	1.06	4.25	13.06	15.56
	5	4.500	1.19	4.38	13.19	15.69
8.00	1 (std)	3.500	1.06	4.44	13.81	16.56
	2	5.500	1.19	4.56	13.93	16.68
	3	4.000	1.06	4.44	13.81	16.56
	4	4.500	1.19	4.56	13.93	16.68
	5	5.000	1.19	4.56	13.93	16.68



Mounting Information – 1.50" to 6.00" Bore Series RDH

Spherical Bearing Cap End Mounting

Inch Size Bearing
Style SB

Note: Standard spherical bearing is maintenance-free (sealed) for hole diameters larger than 0.5000".

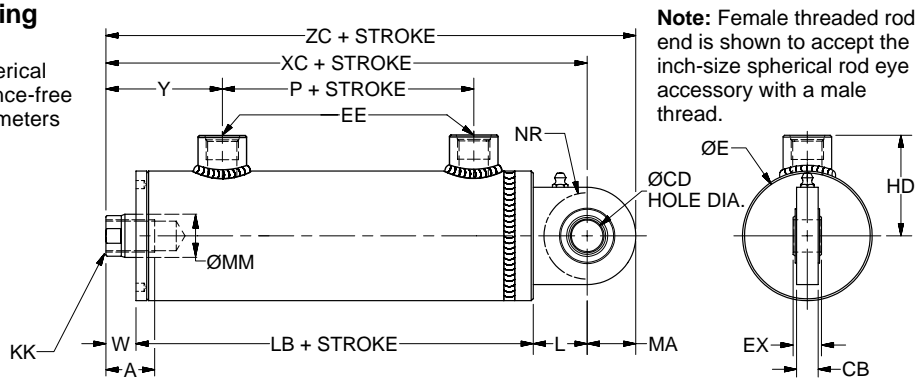
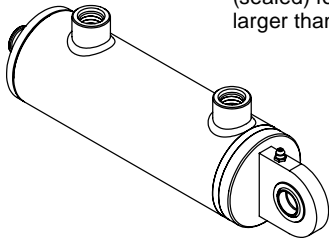

Note: Female threaded rod end is shown to accept the inch-size spherical rod eye accessory with a male thread.

Table 1 — Dimensional and Mounting Data

Bore Ø	Rod No.	MM Rod Ø	Thread		A	CB	CD ² Ø +.0000 - .0005	EX	L	MA	NR min.	W	Y	Add Stroke			
			Style 9A KK ¹	Style 7A KK ¹										XC	ZC		
1.50	1 (std)	0.625	7/16-20	—	0.75	0.38	0.5000	0.44	0.75	0.75	0.56	0.56	2.12	4.87	5.62		
	2	1.000	—	7/16-20	0.75									0.69	2.62	5.38	6.13
2.00	1 (std)	1.000	3/4-16	—	1.13	0.56	0.7500	0.66	1.25	1.00	1.06	0.69	2.51	6.75	7.75		
	2	1.375	—	3/4-16	1.13									0.81	2.63	6.87	7.87
2.50	1 (std)	1.000	3/4-16	—	1.13	0.56	0.7500	0.66	1.25	1.00	1.06	0.69	2.69	7.19	8.19		
	2	1.750	—	3/4-16	1.13									0.94	2.94	7.44	8.44
	3	1.375	—	3/4-16	1.13									0.81	2.81	7.31	8.31
3.25	1 (std)	1.375	1-14	—	1.63	0.75	1.0000	0.88	1.50	1.25	1.31	0.81	3.06	8.31	9.56		
	2	2.000	—	1-14	1.63									1.00	3.25	8.50	9.75
	3	1.750	—	1-14	1.63									0.94	3.19	8.44	9.69
4.00	1 (std)	1.750	1 1/4-12	—	2.00	1.00	1.3750	1.19	2.13	1.88	1.88	0.94	3.40	9.56	11.44		
	2	2.500	—	1 1/4-12	2.00									1.06	3.52	9.69	11.56
	3	2.000	—	1 1/4-12	2.00									1.00	3.46	9.62	11.50
5.00	1 (std)	2.000	1 1/2-12	—	2.25	1.25	1.7500	1.53	2.25	2.50	1.94	1.00	3.70	10.37	12.87		
	2	3.500	—	1 1/2-12	2.25									1.06	3.76	10.43	12.93
	3	2.500	—	1 1/2-12	2.25									1.06	3.76	10.43	12.93
	4	3.000	—	1 1/2-12	2.25									1.06	3.76	10.43	12.93
6.00	1 (std)	2.500	1 7/8-12	—	3.00	1.50	2.0000	1.75	2.50	2.50	2.19	1.06	4.24	11.93	14.43		
	2	4.000	—	1 7/8-12	3.00									1.06	4.24	11.93	14.43
	3	3.000	—	1 7/8-12	3.00									1.06	4.24	11.93	14.43
	4	3.500	—	1 7/8-12	3.00									1.06	4.24	11.93	14.43
7.00	See SBM Mount on the next page																
8.00																	

Note: for additional dimensions see Style BB mount.

² Dimension CD is the hole diameter.

¹ These thread dimensions match mating thread dimensions of an inch-size spherical rod eye with the same hole diameter as the cap end. It must be purchased separately; see Spherical Bearing Mounting Accessories page for detailed information.

Table 2 – Recommended maximum swivel angle on each side of the cylinder centerline.

Bore Ø	Head End Mounted		Cap End Mounted	
	Angle a	Tan. of a	Angle a	Tan. of a
1.50	2.00°	0.035	2.00°	0.035
2.00	2.50°	0.044	4.50°	0.079
2.50	2.50°	0.044	4.50°	0.079
3.25	3.00°	0.052	3.00°	0.052
4.00	2.50°	0.044	3.00°	0.052
5.00	3.00°	0.052	3.00°	0.052
6.00	3.00°	0.052	3.00°	0.052

Note: Dimension X is the maximum off-center mounting of the cylinder. To determine dimension X for various stroke lengths, multiply the distance between pivot pin holes by tangent of angle a. For extended position use XL + 2 x STROKE.

Mounting Information³

Head End Mounting

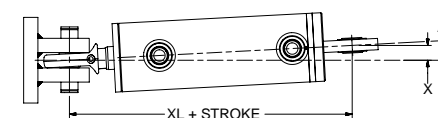

Cap End Mounting

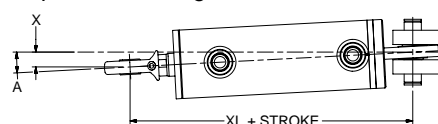

³ See Spherical Bearing Mounting Accessories pages for information on mounting accessories.

SB Pressure Ratings

Bore Ø	Maximum Operating Pressure (psi) ⁴
1.50	1,500
2.00	2,200
2.50	1,450
3.25	1,500
4.00	1,850
5.00	2,000
6.00	1,800

⁴ Pressure ratings are based on standard commercial bearing ratings. For spherical bearing mount rated to 3,000 psi, see the SBM Mount on the next page.

Mounting Information – 1.50" to 8.00" Bore Series RDH

Spherical Bearing Cap End Mounting
Metric Size Bearing
Style SBM

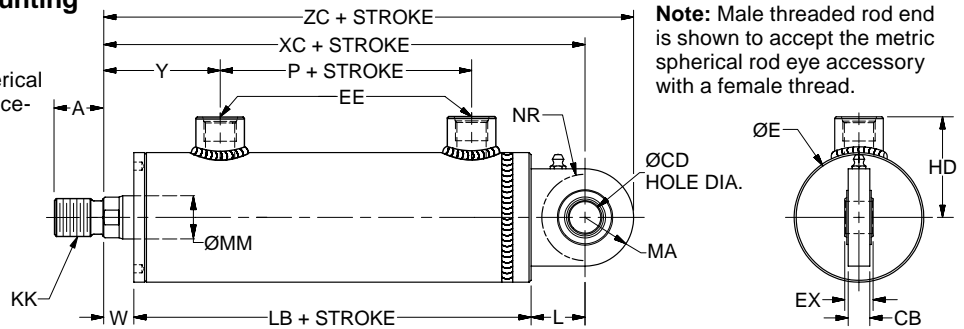
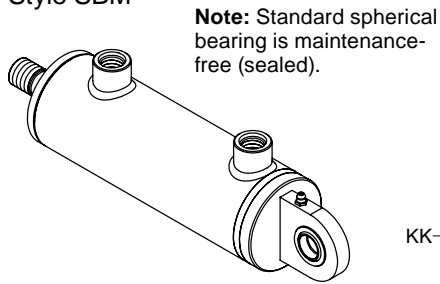

Although the standard SB Mount has derated pressure ratings below 3,000 psi, the SBM Mount is a standard spherical bearing mount rated at 3,000 psi. Note that

the SBM Mount has slightly different lug dimensions and a metric bearing size. See Spherical Bearing Mounting Accessories page for metric size accessories.

Table 1 — Dimensional and Mounting Data

Bore Ø	Rod No.	MM Rod Ø	A ¹ Thread Length (mm)	KK ¹ Thread Style 7M Male	W	Y	Add Stroke		Dimensions at cap end (mm)					
							XC	ZC	CB (mm)	CD ² Ø (mm)	EX (mm)	L (mm)	MA (mm)	NR min. (mm)
1.50	1 (std)	0.625	0.71 (18)	M14X1.5	0.56	2.12	5.11	6.25	0.51 (13)	0.7874 -0.0005 (20 -0.012)	0.63 (16)	0.98 (25)	1.14 (29)	0.87 (22)
	2	1.000	0.71 (18)	M14X1.5	0.69	2.62	5.61	6.75						
2.00	1 (std)	1.000	0.87 (22)	M16X1.5	0.69	2.51	6.72	8.02	0.67 (17)	0.9843 -0.0005 (25 -0.012)	0.79 (20)	1.22 (31)	1.30 (33)	1.10 (28)
	2	1.375	0.87 (22)	M16X1.5	0.81	2.63	6.84	8.14						
2.50	1 (std)	1.000	1.10 (28)	M20X1.5	0.69	2.69	7.43	9.01	0.75 (19)	1.1811 -0.0005 (30 -0.012)	0.87 (22)	1.50 (38)	1.57 (40)	1.38 (35)
	2	1.750	1.10 (28)	M20X1.5	0.94	2.94	7.68	9.26						
	3	1.375	1.10 (28)	M20X1.5	0.81	2.81	7.56	9.13						
3.25	1 (std)	1.375	1.42 (36)	M27X2	0.81	3.06	8.70	10.67	0.91 (23)	1.5748 -0.0005 (40 -0.012)	1.10 (28)	1.89 (48)	1.97 (50)	1.73 (44)
	2	2.000	1.42 (36)	M27X2	1.00	3.25	8.89	10.86						
	3	1.750	1.42 (36)	M27X2	0.94	3.19	8.83	10.80						
4.00	1 (std)	1.750	1.77 (45)	M33X2	0.94	3.40	9.72	12.16	1.18 (30)	1.9685 -0.0005 (50 -0.012)	1.38 (35)	2.28 (58)	2.44 (62)	2.13 (54)
	2	2.500	1.77 (45)	M33X2	1.06	3.52	9.84	12.28						
	3	2.000	1.77 (45)	M33X2	1.00	3.46	9.78	12.22						
5.00	1 (std)	2.000	2.20 (56)	M42X2	1.00	3.70	10.95	14.10	1.50 (38)	2.3622 -0.0006 (60 -0.015)	1.73 (44)	2.83 (72)	3.15 (80)	2.68 (68)
	2	3.500	2.20 (56)	M42X2	1.06	3.76	11.01	14.16						
	3	2.500	2.20 (56)	M42X2	1.06	3.76	11.01	14.16						
	4	3.000	2.20 (56)	M42X2	1.06	3.76	11.01	14.16						
6.00	1 (std)	2.500	2.48 (63)	M48X2	1.06	4.24	13.05	16.99	1.85 (47)	3.1496 -0.0006 (80 -0.015)	2.17 (55)	3.62 (92)	3.94 (100)	3.46 (88)
	2	4.000	2.48 (63)	M48X2	1.06	4.24	13.05	16.99						
	3	3.000	2.48 (63)	M48X2	1.06	4.24	13.05	16.99						
	4	3.500	2.48 (63)	M48X2	1.06	4.24	13.05	16.99						
7.00	1 (std)	3.000	3.35 (85)	M64X3	1.06	4.25	14.63	19.35	2.24 (57)	3.9370 -0.0008 (100 -0.020)	2.76 (70)	4.57 (116)	4.72 (120)	4.37 (111)
	2	5.000	3.35 (85)	M64X3	1.19	4.38	14.75	19.47						
	3	3.500	3.35 (85)	M64X3	1.06	4.25	14.63	19.35						
	4	4.000	3.35 (85)	M64X3	1.06	4.25	14.63	19.35						
	5	4.500	3.35 (85)	M64X3	1.19	4.38	14.75	19.47						
8.00	1 (std)	3.500	3.35 (85)	M64X3	1.06	4.44	15.12	19.85	2.24 (57)	3.9370 -0.0008 (100 -0.020)	2.76 (70)	4.57 (116)	4.72 (120)	4.37 (111)
	2	5.500	3.35 (85)	M64X3	1.19	4.56	15.25	19.97						
	3	4.000	3.35 (85)	M64X3	1.06	4.44	15.12	19.85						
	4	4.500	3.35 (85)	M64X3	1.19	4.56	15.25	19.97						
	5	5.000	3.35 (85)	M64X3	1.19	4.56	15.25	19.97						

Note: for additional dimensions, see Style SB Mount.

² Dimension CD is the hole diameter.

For recommended maximum swivel angles, see Table 2 and sketch on the previous page.

¹ These thread dimensions match mating thread dimensions of a metric spherical rod eye with the same hole diameter as the cap end. It must be purchased separately; see Spherical Bearing Mounting Accessories page for metric sizes for detailed information.

Mounting Information – 1.50" to 8.00" Bore Series RDH

Crosstube Cap End Mounting Style TT

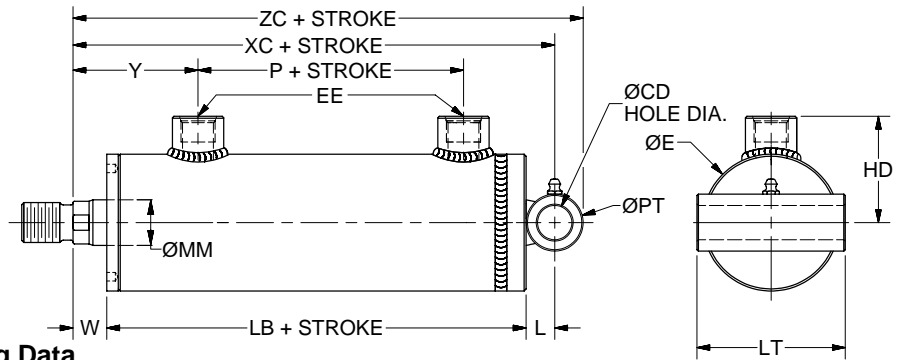
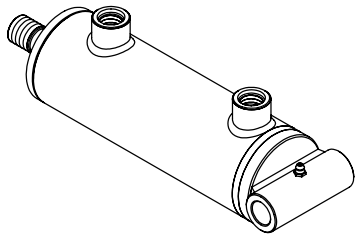

Table 1 – Dimensional and Mounting Data

Bore Ø	Rod No.	CD Ø +0.002 -0.000	E Ø	EE		HD	L	LT	PT Ø	Add Stroke	
				NPTF ¹	SAE ²					LB	P
1.50	1 (std)	0.752	1.88	3/8	6	1.60	0.63	2.38	1.25	3.56	1.19
	2	0.752	1.88	3/8	6	1.60	0.63	2.38	1.25	3.94	1.19
2.00	All	0.752	2.38	1/2	8	2.04	0.63	2.88	1.25	4.81	1.93
2.50	All	1.002	3.00	1/2	8	2.37	0.75	3.50	1.50	5.25	1.88
3.25	All	1.252	3.88	3/4	12	2.81	0.94	4.38	1.88	6.00	2.06
4.00	All	1.377	4.61	3/4	12	3.20	1.00	5.13	2.00	6.50	2.50
5.00	All	1.752	5.75	3/4	12	3.79	1.38	6.25	2.75	7.12	2.56
6.00	All	2.002	7.00	1	16	4.58	1.50	7.50	3.00	8.37	3.00
7.00	All	2.502	8.00	1 1/4	20	5.11	1.88	8.50	3.75	9.00	3.25
8.00	All	3.002	9.25	1 1/4	20	5.76	2.00	9.75	4.00	9.50	3.25

¹ NPTF ports are available for no additional charge ² SAE straight thread o-ring ports are standard

Table 2 – Dimensional and Mounting Data

Bore Ø	Rod No.	MM Rod Ø	W	Y	Add Stroke	
					XC	ZC
1.50	1 (std)	0.625	0.56	2.12	4.75	5.37
	2	1.000	0.69	2.62	5.25	5.88
2.00	1 (std)	1.000	0.69	2.51	6.13	6.75
	2	1.375	0.81	2.63	6.25	6.87
2.50	1 (std)	1.000	0.69	2.69	6.69	7.44
	2	1.750	0.94	2.94	6.94	7.69
	3	1.375	0.81	2.81	6.81	7.56
3.25	1 (std)	1.375	0.81	3.06	7.75	8.69
	2	2.000	1.00	3.25	7.94	8.88
	3	1.750	0.94	3.19	7.88	8.81
4.00	1 (std)	1.750	0.94	3.40	8.44	9.44
	2	2.500	1.06	3.52	8.56	9.56
	3	2.000	1.00	3.46	8.50	9.50
5.00	1 (std)	2.000	1.00	3.70	9.49	10.87
	2	3.500	1.06	3.76	9.55	10.93
	3	2.500	1.06	3.76	9.55	10.93
	4	3.000	1.06	3.76	9.55	10.93
6.00	1 (std)	2.500	1.06	4.24	10.93	12.43
	2	4.000	1.06	4.24	10.93	12.43
	3	3.000	1.06	4.24	10.93	12.43
	4	3.500	1.06	4.24	10.93	12.43
7.00	1 (std)	3.000	1.06	4.25	11.94	13.81
	2	5.000	1.19	4.38	12.06	13.94
	3	3.500	1.06	4.25	11.94	13.81
	4	4.000	1.06	4.25	11.94	13.81
	5	4.500	1.19	4.38	12.06	13.94
8.00	1 (std)	3.500	1.06	4.44	12.56	14.56
	2	5.500	1.19	4.56	12.68	14.68
	3	4.000	1.06	4.44	12.56	14.56
	4	4.500	1.19	4.56	12.68	14.68
	5	5.000	1.19	4.56	12.68	14.68

Mounting Information – 1.50" to 8.00" Bore Series RDH

Intermediate Fixed Trunnion Mounting Style DD

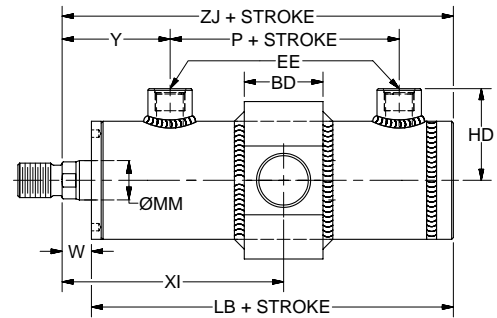
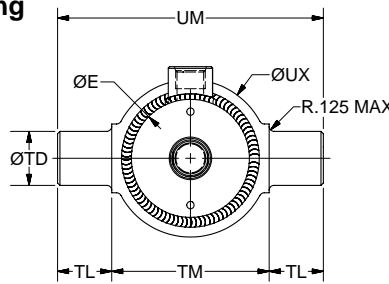
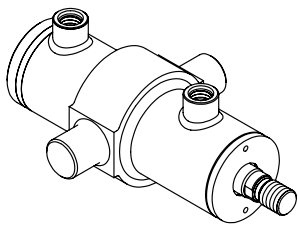

Table 1 – Dimensional and Mounting Data

Bore Ø	Rod No.	BD	E Ø	EE		HD	TD Ø +.000 - .001	TL	TM	UM	UX Ø	Add Stroke	
				NPTF ¹	SAE ²							LB	P
1.50	1 (std)	1.31	1.88	3/8	6	1.60	1.000	1.00	3.00	5.00	3.00	3.56	1.19
	2	1.31	1.88	3/8	6	1.60	1.000	1.00	3.00	5.00	3.00	3.94	1.19
2.00	All	1.69	2.38	1/2	8	2.04	1.375	1.38	3.50	6.25	3.50	4.81	1.93
2.50	All	1.69	3.00	1/2	8	2.37	1.375	1.38	4.00	6.75	4.00	5.25	1.88
3.25	All	2.19	3.88	3/4	12	2.81	1.750	1.75	5.00	8.50	5.00	6.00	2.06
4.00	All	2.44	4.61	3/4	12	3.20	2.000	1.75	5.50	9.00	6.00	6.50	2.50
5.00	All	2.88	5.75	3/4	12	3.79	2.500	1.75	7.00	10.50	7.38	7.12	2.56
6.00	All	3.38	7.00	1	16	4.58	3.000	2.00	8.50	12.50	9.00	8.37	3.00
7.00	All	3.88	8.00	1 1/4	20	5.11	3.500 ³	2.50	9.75	14.75	10.25	9.00	3.25
8.00	All	4.44	9.25	1 1/4	20	5.76	4.000 ³	3.00	11.00	17.00	11.75	9.50	3.25

¹ NPTF ports are available for no additional charge ² SAE straight thread o-ring ports are standard ³ Tolerance is +.000/-.002

Table 2 – Dimensional and Mounting Data

Bore Ø	Rod No.	MM Rod Ø	W	Y	Min. Stroke ⁴	Min. XI ⁵	Add Stroke	
							Max. XI ⁶	ZJ
1.50	1 (std)	0.625	0.56	2.12	3.03	4.25	1.19	4.12
	2	1.000	0.69	2.62	3.03	4.75	1.69	4.63
2.00	1 (std)	1.000	0.69	2.51	3.12	4.95	2.00	5.50
	2	1.375	0.81	2.63	3.12	5.07	2.12	5.62
2.50	1 (std)	1.000	0.69	2.69	2.98	5.13	2.13	5.94
	2	1.750	0.94	2.94	2.98	5.38	2.38	6.19
	3	1.375	0.81	2.81	2.98	5.25	2.25	6.06
3.25	1 (std)	1.375	0.81	3.06	3.61	5.87	2.31	6.81
	2	2.000	1.00	3.25	3.61	6.06	2.50	7.00
	3	1.750	0.94	3.19	3.61	6.00	2.44	6.94
4.00	1 (std)	1.750	0.94	3.40	3.52	6.33	2.96	7.44
	2	2.500	1.06	3.52	3.52	6.46	3.08	7.56
	3	2.000	1.00	3.46	3.52	6.40	3.02	7.50
5.00	1 (std)	2.000	1.00	3.70	3.88	6.89	3.07	8.12
	2	3.500	1.06	3.76	3.88	6.95	3.13	8.18
	3	2.500	1.06	3.76	3.88	6.95	3.13	8.18
	4	3.000	1.06	3.76	3.88	6.95	3.13	8.18
6.00	1 (std)	2.500	1.06	4.24	4.46	7.87	3.62	9.43
	2	4.000	1.06	4.24	4.46	7.87	3.62	9.43
	3	3.000	1.06	4.24	4.46	7.87	3.62	9.43
	4	3.500	1.06	4.24	4.46	7.87	3.62	9.43
7.00	1 (std)	3.000	1.06	4.25	5.10	8.38	3.38	10.06
	2	5.000	1.19	4.38	5.10	8.51	3.51	10.19
	3	3.500	1.06	4.25	5.10	8.38	3.38	10.06
	4	4.000	1.06	4.25	5.10	8.38	3.38	10.06
	5	4.500	1.19	4.38	5.10	8.51	3.51	10.19
8.00	1 (std)	3.500	1.06	4.44	5.54	8.81	3.31	10.56
	2	5.500	1.19	4.56	5.54	8.94	3.44	10.68
	3	4.000	1.06	4.44	5.54	8.81	3.31	10.56
	4	4.500	1.19	4.56	5.54	8.94	3.44	10.68
	5	5.000	1.19	4.56	5.54	8.94	3.44	10.68

⁴ Shorter net/working strokes are available with the use of a stop tube; however, the overall length of the cylinder will increase. To achieve a net/working stroke that is less than the minimum shown, specify the stop tube length as the minimum stroke in Table 2. Gross stroke (designated in the model code) will be the combination of the stop tube length and net (working) stroke length. If shortest total cylinder length is required and a stop tube is unacceptable, consult the factory.

⁵ Cylinders with an XI dimension shorter than the standard minimum are available with a special modification; consult the factory.

⁶ Add this number to the stroke to determine the maximum allowable XI dimension with the standard rod extension (W dimension).



Mounting Information – 1.50" to 8.00" Bore Series RDH

Round Head Flange Mounting

Style J

Style JP – with close tolerance pilot

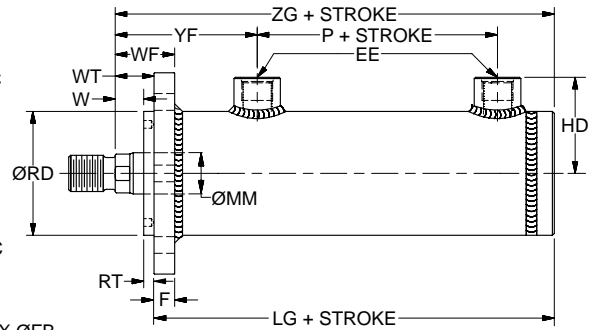
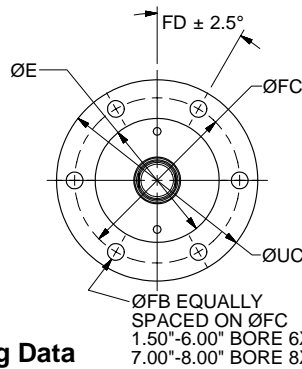
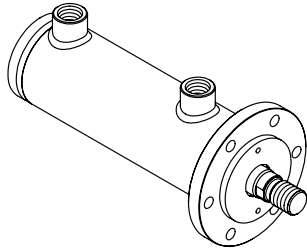

Table 1 – Dimensional and Mounting Data

Bore Ø	E Ø	EE		F	FB Ø	FC Ø	FD	HD	RD Ø		UC Ø	Add Stroke	
		NPTF ¹	SAE ²						Style J	Style JP +0.000 / -0.002		LG	P
1.50	1.88	3/8	6	0.38	0.28	2.75	30°	1.60	1.88	1.810	3.38	3.94	1.19
2.00	2.38	1/2	8	0.44	0.34	3.31	30°	2.04	2.38	2.310	4.00	5.31	1.93
2.50	3.00	1/2	8	0.50	0.41	4.13	30°	2.37	3.00	2.936	5.00	5.75	1.88
3.25	3.88	3/4	12	0.63	0.53	5.25	30°	2.81	3.88	3.810	6.38	6.50	2.06
4.00	4.61	3/4	12	0.75	0.66	6.25	30°	3.20	4.61	4.560	7.63	7.00	2.50
5.00	5.75	3/4	12	0.88	0.78	7.50	30°	3.79	5.75	5.686	9.00	7.55	2.56
6.00	7.00	1	16	1.00	0.91	9.13	30°	4.58	6.99	6.936	10.94	8.75	3.00
7.00	8.00	1 1/4	20	1.00	0.91	10.13	22.5°	5.11	7.99	7.936	11.94	9.63	3.25
8.00	9.25	1 1/4	20	1.13	1.06	11.63	22.5°	5.76	9.24	9.186	13.75	10.00	3.25

¹ NPTF ports are available for no additional charge ² SAE straight thread o-ring ports are standard

Table 2 – Dimensional and Mounting Data

Bore Ø	Rod No.	MM Rod Ø	RT	W	WF	WT	YF	Add Stroke
								ZG
1.50	1 (std)	0.625	0.25	0.56	1.19	0.81	2.75	4.75
	2	1.000	0.63	0.69	1.69	1.31	3.25	5.25
2.00	1 (std)	1.000	0.25	0.69	1.38	0.94	3.26	6.25
	2	1.375	0.25	0.81	1.50	1.06	3.38	6.37
2.50	1 (std)	1.000	0.25	0.69	1.44	0.94	3.44	6.69
	2	1.750	0.25	0.94	1.69	1.19	3.69	6.94
	3	1.375	0.25	0.81	1.56	1.06	3.56	6.81
3.25	1 (std)	1.375	0.25	0.81	1.69	1.06	3.82	7.56
	2	2.000	0.25	1.00	1.88	1.25	4.00	7.75
	3	1.750	0.25	0.94	1.81	1.19	3.94	7.69
4.00	1 (std)	1.750	0.25	0.94	1.94	1.19	4.14	8.19
	2	2.500	0.25	1.06	2.06	1.31	4.27	8.31
	3	2.000	0.25	1.00	2.00	1.25	4.21	8.25
5.00	1 (std)	2.000	0.31	1.00	2.19	1.31	4.45	8.87
	2	3.500	0.31	1.06	2.25	1.37	4.51	8.93
	3	2.500	0.31	1.06	2.25	1.37	4.51	8.93
	4	3.000	0.31	1.06	2.25	1.37	4.51	8.93
6.00	1 (std)	2.500	0.38	1.06	2.44	1.44	4.99	10.18
	2	4.000	0.38	1.06	2.44	1.44	4.99	10.18
	3	3.000	0.38	1.06	2.44	1.44	4.99	10.18
	4	3.500	0.38	1.06	2.44	1.44	4.99	10.18
7.00	1 (std)	3.000	0.38	1.06	2.44	1.44	5.25	11.06
	2	5.000	0.38	1.19	2.56	1.56	5.38	11.19
	3	3.500	0.38	1.06	2.44	1.44	5.25	11.06
	4	4.000	0.38	1.06	2.44	1.44	5.25	11.06
	5	4.500	0.38	1.19	2.56	1.56	5.38	11.19
8.00	1 (std)	3.500	0.50	1.06	2.69	1.56	5.44	11.56
	2	5.500	0.50	1.19	2.81	1.69	5.56	11.68
	3	4.000	0.50	1.06	2.69	1.56	5.44	11.56
	4	4.500	0.50	1.19	2.81	1.69	5.56	11.68
	5	5.000	0.50	1.19	2.81	1.69	5.56	11.68

Note: Mounting Styles J/JP, in 1.50 - 6.00 inch bores, has 6 equally spaced bolt holes in the mounting flange. The bolt pattern is oriented to allow clearance for assembling mounting bolts when ports or switches are in positions 1 and/or 3. This bolt pattern orientation puts one hole each at positions 2 and 3, which results in bolt interference with ports or switches specified there. Consequently, ports or switches are not available in position J/2 or 4 on the head end of mounting Styles J/JP.

Installations that require a switch and port(s) located 90 degrees apart, on the head end of mounting Styles J/JP, can be accommodated by welding the flange with the mounting bolt pattern rotated slightly or with a special bolt size and quantity. Contact the factory in these cases.

Mounting Information – 1.50" to 8.00" Bore Series RDH

Round Cap Flange Mounting Style H

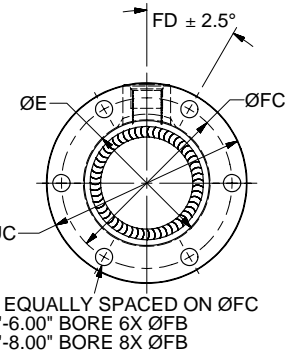
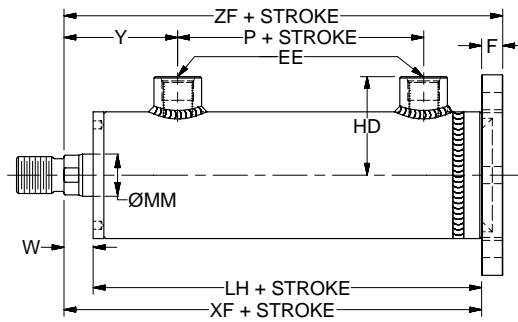
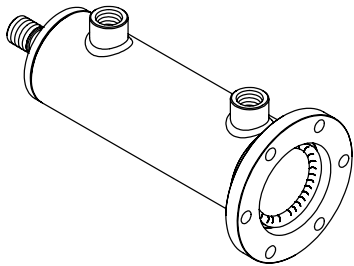

Table 1 – Dimensional and Mounting Data

Bore Ø	Rod No.	E Ø	EE		F	FB Ø	FC Ø	FD	HD	UC Ø	Add Stroke	
			NPTF ¹	SAE ²							LH	P
1.50	1 (std)	1.88	3/8	6	0.38	0.28	2.75	30°	1.60	3.38	3.44	1.19
	2	1.88	3/8	6	0.38	0.28	2.75	30°	1.60	3.38	3.81	1.19
2.00	All	2.38	1/2	8	0.44	0.34	3.31	30°	2.04	4.00	4.69	1.93
2.50	All	3.00	1/2	8	0.50	0.41	4.13	30°	2.37	5.00	5.13	1.88
3.25	All	3.88	3/4	12	0.63	0.53	5.25	30°	2.81	6.38	5.88	2.06
4.00	All	4.61	3/4	12	0.75	0.66	6.25	30°	3.20	7.63	6.37	2.50
5.00	All	5.75	3/4	12	0.88	0.78	7.50	30°	3.79	9.00	6.99	2.56
6.00	All	7.00	1	16	1.00	0.91	9.13	30°	4.58	10.94	8.25	3.00
7.00	All	8.00	1 1/4	20	1.00	0.91	10.13	22.5°	5.11	11.94	8.88	3.25
8.00	All	9.25	1 1/4	20	1.13	1.06	11.63	22.5°	5.76	13.75	9.37	3.25

¹ NPTF ports are available for no additional charge

² SAE straight thread o-ring ports are standard

Table 2 – Dimensional and Mounting Data

Bore Ø	Rod No.	MM Rod Ø	W	Y	Add Stroke	
					XF	ZF
1.50	1 (std)	0.625	0.56	2.12	4.00	4.37
	2	1.000	0.69	2.62	4.50	4.88
2.00	1 (std)	1.000	0.69	2.51	5.38	5.81
	2	1.375	0.81	2.63	5.50	5.94
2.50	1 (std)	1.000	0.69	2.69	5.81	6.31
	2	1.750	0.94	2.94	6.06	6.56
	3	1.375	0.81	2.81	5.94	6.44
3.25	1 (std)	1.375	0.81	3.07	6.69	7.31
	2	2.000	1.00	3.25	6.88	7.50
	3	1.750	0.94	3.19	6.81	7.44
4.00	1 (std)	1.750	0.94	3.39	7.31	8.06
	2	2.500	1.06	3.52	7.44	8.19
	3	2.000	1.00	3.46	7.37	8.12
5.00	1 (std)	2.000	1.00	3.70	7.99	8.87
	2	3.500	1.06	3.76	8.05	8.93
	3	2.500	1.06	3.76	8.05	8.93
	4	3.000	1.06	3.76	8.05	8.93
6.00	1 (std)	2.500	1.06	4.24	9.31	10.31
	2	4.000	1.06	4.24	9.31	10.31
	3	3.000	1.06	4.24	9.31	10.31
	4	3.500	1.06	4.24	9.31	10.31
7.00	1 (std)	3.000	1.06	4.25	9.94	10.94
	2	5.000	1.19	4.38	10.06	11.06
	3	3.500	1.06	4.25	9.94	10.94
	4	4.000	1.06	4.25	9.94	10.94
	5	4.500	1.19	4.38	10.06	11.06
8.00	1 (std)	3.500	1.06	4.44	10.43	11.56
	2	5.500	1.19	4.56	10.56	11.68
	3	4.000	1.06	4.44	10.43	11.56
	4	4.500	1.19	4.56	10.56	11.68
	5	5.000	1.19	4.56	10.56	11.68

Note: Mounting Style H, in 1.50 - 6.00 inch bores, has 6 equally spaced bolt holes in the mounting flange. The bolt pattern is oriented to allow clearance for assembling mounting bolts when ports or switches are in positions 1 and/or 3. This bolt pattern orientation puts one hole each at positions 2 and 3, which results in bolt interference with ports or switches specified there. Consequently, ports or switches are not available in position 2 or 4 on the cap end of mounting Style H.

Installations that require a switch and port(s) located 90 degrees apart, on the cap end of mounting Style H, can be accommodated by welding the flange with the mounting bolt pattern rotated slightly or with a special bolt size and quantity. Contact the factory in these cases.



**Double Rod Cylinder
Styles KT & KDD**

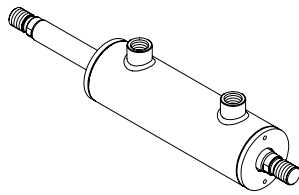

Styles KJ / KJP

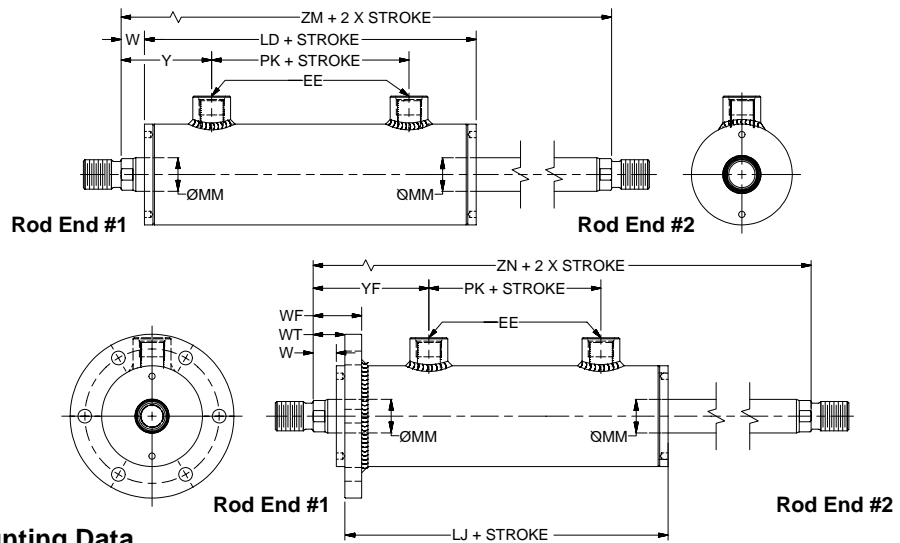
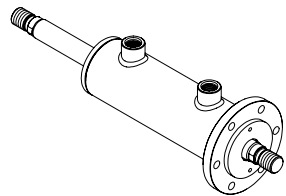

Table 1 – Dimensional and Mounting Data

Bore Ø	Rod No.	MM Rod Ø	EE		W	PK	Styles KJ / KJP					All Other Mounts		
			NPTF	SAE			WF	WT	YF	LJ	ZN	Y	LD	ZM
1.50	1 (std)	0.625	3/8	6	0.56	1.22	1.19	0.81	2.87	4.78	6.10	2.12	4.34	5.48
	2	1.000	3/8	6	0.69	1.22	1.69	1.31	3.37	4.78	7.10	2.62	5.09	6.48
2.00	1 (std)	1.000	1/2	8	0.69	1.76	1.38	0.94	3.26	6.09	7.53	2.51	5.40	6.78
	2	1.375	1/2	8	0.81	1.76	1.50	1.06	3.38	6.09	7.78	2.63	5.40	7.03
2.50	1 (std)	1.000	1/2	8	0.69	1.90	1.44	0.94	3.44	6.78	8.03	2.69	5.90	7.28
	2	1.750	1/2	8	0.94	1.90	1.69	1.19	3.69	6.78	8.53	2.94	5.90	7.78
	3	1.375	1/2	8	0.81	1.90	1.56	1.06	3.56	6.78	8.28	2.81	5.90	7.53
3.25	1 (std)	1.375	3/4	12	0.81	2.02	1.69	1.06	3.82	7.59	8.90	3.07	6.53	8.15
	2	2.000	3/4	12	1.00	2.02	1.88	1.25	4.00	7.59	9.28	3.25	6.53	8.53
	3	1.750	3/4	12	0.94	2.02	1.81	1.19	3.94	7.59	9.16	3.19	6.53	8.41
4.00	1 (std)	1.750	3/4	12	0.94	2.35	1.94	1.19	4.14	8.10	9.91	3.39	7.27	9.16
	2	2.500	3/4	12	1.06	2.35	2.06	1.31	4.27	8.10	10.15	3.52	7.27	9.40
	3	2.000	3/4	12	1.00	2.35	2.00	1.25	4.21	8.10	10.03	3.46	7.27	9.28
5.00	1 (std)	2.000	3/4	12	1.00	2.50	2.19	1.31	4.45	8.70	10.66	3.70	7.90	9.91
	2	3.500	3/4	12	1.06	2.50	2.25	1.37	4.51	8.70	10.78	3.76	7.90	10.03
	3	2.500	3/4	12	1.06	2.50	2.25	1.37	4.51	8.70	10.78	3.76	7.90	10.03
	4	3.000	3/4	12	1.06	2.50	2.25	1.37	4.51	8.70	10.78	3.76	7.90	10.03
6.00	1 (std)	2.500	1	16	1.06	2.79	2.44	1.44	4.99	10.02	12.03	4.24	9.15	11.28
	2	4.000	1	16	1.06	2.79	2.44	1.44	4.99	10.02	12.03	4.24	9.15	11.28
	3	3.000	1	16	1.06	2.79	2.44	1.44	4.99	10.02	12.03	4.24	9.15	11.28
	4	3.500	1	16	1.06	2.79	2.44	1.44	4.99	10.02	12.03	4.24	9.15	11.28
7.00	1 (std)	3.000	1 1/4	20	1.06	3.16	2.44	1.44	5.25	10.97	12.67	4.25	9.54	11.67
	2	5.000	1 1/4	20	1.19	3.16	2.56	1.56	5.38	10.97	12.92	4.38	9.54	11.92
	3	3.500	1 1/4	20	1.06	3.16	2.44	1.44	5.25	10.97	12.67	4.25	9.54	11.67
	4	4.000	1 1/4	20	1.06	3.16	2.44	1.44	5.25	10.97	12.67	4.25	9.54	11.67
	5	4.500	1 1/4	20	1.19	3.16	2.56	1.56	5.38	10.97	12.92	4.38	9.54	11.92
8.00	1 (std)	3.500	1 1/4	20	1.06	3.21	2.69	1.56	5.44	11.46	13.09	4.44	9.96	12.09
	2	5.500	1 1/4	20	1.19	3.21	2.81	1.69	5.56	11.46	13.34	4.56	9.96	12.34
	3	4.000	1 1/4	20	1.06	3.21	2.69	1.56	5.44	11.46	13.09	4.44	9.96	12.09
	4	4.500	1 1/4	20	1.19	3.21	2.81	1.69	5.56	11.46	13.34	4.56	9.96	12.34
	5	5.000	1 1/4	20	1.19	3.21	2.81	1.69	5.56	11.46	13.34	4.56	9.96	12.34

How to Use Double Rod Cylinder Drawing Dimensions

To determine the dimensions for a double rod cylinder, first refer to the desired mounting style of the single rod version, as seen in the preceding pages of this catalog. When you have the required dimensions from that drawing, return to this page to supplement and replace the single rod dimensions with those shown on the double rod drawing and table above. Note that double rod cylinders have a head at both ends and that dimension LD replaces LB, and LJ replaces LG. The double rod dimensions differ from, or are in addition to those for single rod cylinders shown on

preceding pages and provide the information needed to completely dimension a double rod cylinder.

On a double rod cylinder where the two rod ends are different, be sure to clearly state which rod end is to be assembled at which end. Port position 1 is standard. If other than standard, specify position 2, 3 or 4 when viewed from rod end #1 only. See Port information page for more details.

Rod End Accessories

Accessories offered for the rod end of the cylinder include: Rod Clevis, Eye Bracket, Knuckle, Clevis Bracket and Pivot Pin. To select the proper part number for any desired rod mounted accessory, refer to the table below and look opposite the thread size of the rod end as indicated in the first column. The Pivot Pins, Eye Brackets and Clevis Brackets are listed opposite the pin diameter that fits their mating Knuckles or Clevises.

Accessory Load Capacity

The various accessories on this and the following pages have been load rated for your convenience. The load capacity, shown in the table below, is the recommended maximum load for that accessory based on a 4:1 design factor in tension. (Pivot Pin is rated in shear.) Before specifying, compare the actual load or the tension (pull) force at maximum operating pressure of the cylinder with the load capacity of the accessory you plan to use. If load or pull force of cylinder exceeds load capacity of accessory, consult factory.

Thread Size	Pin Ø	Rod Clevis		Mounting Plate or Eye Bracket		Pivot Pin	
		Part Number	Load Capacity (lb)	Forged Steel or Cast Ductile Iron		Part Number	Shear Capacity (lb)
				Part Number	Load Capacity (lb)		
5/16-24	0.312	0512210000 ¹	2600	0959810031	1850	—	—
7/16-20	0.500	0509400000	4250	0959810050 ²	4620	0683680000	8600
1/2-20	0.500	0509410000	4900	0959810050 ²	4620	0683680000	8600
3/4-16	0.750	0509420000	11200	0959810075 ²	12370	0683690000	19300
3/4-16	0.750	1332840000	11200	0959810075 ²	12370	0683690000	19300
7/8-14	1.000	0509430000	18800	0959810100 ²	20450	0683700000	34300
1-14	1.000	0509440000	19500	0959810100 ²	20450	0683700000	34300
1-14	1.000	1332850000	19500	0959810100 ²	20450	0683700000	34300
1 1/4-12	1.375	0509450000	33500	0959810138	33500	0683710000	65000
1 1/4-12	1.375	1332860000	33500	0959810138	33500	0683710000	65000
1 1/2-12	1.750	0509460000	45600	0959810175	49480	0683720000	105200
1 3/4-12	2.000	0509470000	65600	0959810200 ²	70100	0683730000	137400
1 7/8-12	2.000	0509480000	65600	0959810200 ²	70100	0683730000	137400
2 1/4-12	2.500	0509490000	98200	0959810250 ²	98200	0683740000	214700
2 1/2-12	3.000	0509500000	98200	0959810300 ²	121940	0683750000	309200
2 3/4-12	3.000	0509510000	98200	0959810300 ²	121940	0683750000	309200
3 1/4-12	3.500	0509520000	156700	0959810350	187910	0735450000	420900
3 1/2-12	4.000	0509530000	193200	0959810400	268000	0735470000	565800
4-12	4.000	0509540000	221200	0959810400	268000	0735470000	565800

¹ Includes pivot pin. ² Cylinder accessory dimensions conform to ANSI/NFPA/T3.6.8 R3-2010

Forged Steel or Cast Ductile Iron Mounting Plate or Eye Bracket Dimensions³

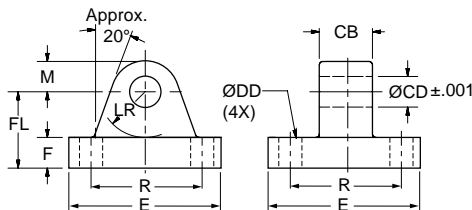

Note: Cast ductile iron eye brackets must not be welded in place.

Cast or Forged Part Number ⁵	Pin Ø	CB	CD Ø	DD Ø	E (As Cast)	F	FL	LR	M (As Cast)	R	For Use With BB Mount Per Bore
0959810031	0.312	0.31	0.314	0.27	2.25	0.38	1.00	0.59	0.38	1.75	—
0959810050	0.500	0.75	0.503	0.41	2.50	0.38	1.13	0.69	0.50	1.63	1.50
095981B075	0.750	1.06	0.750	0.53	3.50	0.63	1.88	1.06	0.75	2.55	2.00
0959810075	0.750	1.25	0.753	0.53	3.50	0.63	1.88	1.13	0.75	2.55	2.50
0959810100	1.000	1.50	1.003	0.66	4.50	0.88	2.38	1.37	1.00	3.25	3.25
0959810138	1.375	2.00	1.378	0.66	5.00	1.00 ⁴	3.00	1.88	1.38	3.82	4.00
0959810175	1.750	2.50	1.753	0.91	6.50	1.25 ⁴	3.38	2.13	1.75	4.95	5.00
0959810200	2.000	2.50	2.003	1.06	7.50	1.50	4.00	2.38	2.00	5.73	6.00
0959810250	2.500	3.00	2.503	1.19	8.50	1.75	4.75	2.88	2.50	6.58	7.00
0959810300	3.000	3.00	3.003	1.31	9.50	2.00	5.25	3.13	3.00	7.50	8.00
0959810350	3.500	4.00	3.503	1.81	12.63	2.50 ⁶	6.50 ⁶	3.88	3.50	9.62	—
0959810400	4.000	4.50	4.003	2.06	14.88	3.00 ⁶	7.50 ⁶	4.38	4.06	11.45	—

³ When used to mate with the Rod Clevis, select by pin diameter in the table above.

⁴ These dimensions vary from NFPA standard. F is increased by 0.13. Sufficient LR clearance remains for full swing arc with cap clevis cylinders and rod clevises.

⁵ Eye Brackets with pin diameters 0.500 thru 1.000 are forged steel. Eye Brackets with 0.312 and 1.375 pin diameter and larger are cast ductile iron.

⁶ Mounting base thickness dimension F is increased on these sizes to provide greater load capacity than the former fabricated steel design. Cast ductile iron dimensions F and FL are 0.81 larger for 3.500 pin diameter and 1.06 larger for 4.000 pin diameter.

Rod Clevis Dimensions

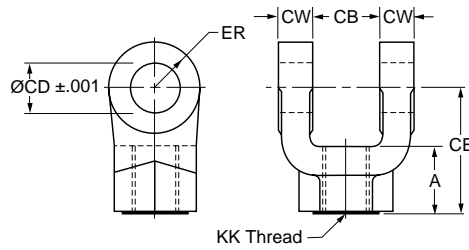

Part Number ¹	Pin Ø	A	CB	CD Ø	CE	CW	ER	KK Thread
0512210000 ²	0.312	0.81	0.34	0.314	2.25	0.20	0.30	5/16-24
0509400000	0.500	0.75	0.77	0.503	1.50	0.49	0.50	7/16-20
0509410000	0.500	0.75	0.77	0.503	1.50	0.49	0.50	1/2-20
0509420000	0.750	1.13	1.27	0.753	2.13	0.62	0.75	3/4-16
1332840000	0.750	1.13	1.27	0.753	2.38	0.62	0.75	3/4-16
0509430000	1.000	1.63	1.52	1.003	2.94	0.74	1.00	7/8-14
0509440000	1.000	1.63	1.52	1.003	2.94	0.74	1.00	1-14
1332850000	1.000	1.63	1.52	1.003	3.13	0.74	1.00	1-14
0509450000	1.375	1.88	2.04	1.378	3.75	0.99	1.38	1 1/4-12
1332860000	1.375	2.00	2.04	1.378	4.13	0.99	1.38	1 1/4-12
0509460000	1.750	2.25	2.54	1.753	4.50	1.24	1.75	1 1/2-12
0509470000	2.000	3.00	2.54	2.003	5.50	1.24	2.00	1 3/4-12
0509480000	2.000	3.00	2.54	2.003	5.50	1.24	2.00	1 7/8-12
0509490000	2.500	3.50	3.04	2.503	6.50	1.49	2.50	2 1/4-12
0509500000	3.000	3.50	3.04	3.003	6.75	1.49	2.75	2 1/2-12
0509510000	3.000	3.50	3.04	3.003	6.75	1.49	2.75	2 3/4-12
0509520000	3.500	3.50 ³	4.04	3.503	7.75	1.98	3.50	3 1/4-12
0509530000	4.000	4.00 ³	4.54	4.003	8.81	2.23	4.00	3 1/2-12
0509540000	4.000	4.00 ³	4.54	4.003	8.81	2.23	4.00	4-12

¹ Rod Clevises with pin diameters .312 thru 1.375 are forged steel. Rod Clevises with 1.750 pin diameters and larger are cast ductile iron.

² Includes Pivot Pin

³ Consult appropriate cylinder rod end dimensions for compatibility.

Pivot Pin Dimensions

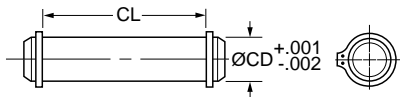

Part Number	CD Ø	CL
0683680000	0.500	1.88
0683690000	0.750	2.63
0683700000	1.000	3.13
0683710000	1.375	4.19
0683720000	1.750	5.19
0683730000	2.000	5.19
0683740000	2.500	6.19
0683750000	3.000	6.25
0735450000	3.500	8.25
0735470000 ⁴	4.000	9.00

Notes:

- Pivot Pins are furnished with Clevis Mounted Cylinders as standard.
- Pivot Pins are furnished with (2) Retainer Rings.
- Pivot Pins must be ordered as a separate item if to be used with Knuckles, Rod Clevises, or Clevis Brackets.

⁴ This size supplied with cotter pins.

Rod End Accessories

Accessories offered for the rod end of the cylinder include Rod Clevis, Eye Bracket, Knuckle, Clevis Bracket, and Pivot Pin. To select the proper part number for any rod mounted accessory, refer to the table below and look in the row to the right of the rod thread in the first column. The Pivot Pins, Eye Brackets and Clevis Brackets are listed opposite the pin diameter that fits their mating Knuckles or Clevises.

Accessory Load Capacity

The various accessories have been load rated for your convenience. The load capacity, shown in the table below, is the recommended maximum load for that accessory based on a 4:1 design factor in tension. (Pivot Pin is rated in shear.) Before specifying, compare the actual load or the tension (pull) force at the maximum operating pressure of the cylinder with the load capacity of the accessory you plan to use. If load or pull force of cylinder exceeds load capacity of accessory, consult factory.

Thread Size	Pin Ø	Knuckle		Clevis Bracket				Pivot Pin	
		Part Number	Load Capacity (lb)	Forged Steel or Cast Ductile Iron		Fabricated Steel		Part Number	Shear Capacity (lb)
				Part Number	Load Capacity (lb)	Part Number	Load Capacity (lb)		
5/16-24	0.438	0740750000	3300	0960160044	2830	0740760000	3600	0740780000	6600
7/16-20	0.500	0690890000	5000	0960160050	7740	0692050000	7300	0683680000	8600
1/2-20	0.500	0690900000	5700	0960160050	7740	0692050000	7300	0683680000	8600
3/4-16	0.750	0690910000	12100	0960160075	13600	0692060000	10880	0683690000	19300
7/8-14	1.000	0690920000	13000	0960160100	23000	0692070000	15180	0683700000	34300
1-14	1.000	0690930000	21700	0960160100	23000	0692070000	15180	0683700000	34300
1 1/4-12	1.375	0690940000	33500	0960160138	39500	0692080000	23560	0683710000	65000
1 1/2-12	1.750	0690950000	45000	0960160175	49480	0692090000	21520	0683720000	105200
1 3/4-12	2.000	0690960000	53500	0960160200	72400	0692100000	26000	0692150000	137400
1 7/8-12	2.000	0962160000	75000	0960160200	72400	0692100000	26000	0692150000	137400
2 1/4-12	2.500	0962170000	98700	0960160250	98700	0692110000	28710	0683740000	214700
2 1/2-12	3.000	0962180000	110000	0960160300	123300	0692120000	28190	0683750000	309200
2 3/4-12	3.000	0962190000	123300	N/A	N/A	0692130000	31390	0692160000	309200
3 1/4-12	3.500	0962200000	161300	0960160350	200400	0735420000	80250	0735450000	420900
3 1/2-12	3.500	0962210000	217300	0960160350	200400	0735420000	80250	0735450000	420900
4-12	4.000	0962220000	273800	0960160400	292100	0735430000	98420	0821810000	565800
N/A	4.000	N/A	N/A	N/A	N/A	N/A	N/A	0735470000 ¹	565800

¹ This size supplied with cotter pins.

Forged Steel or Cast Ductile Iron Clevis Bracket Dimensions

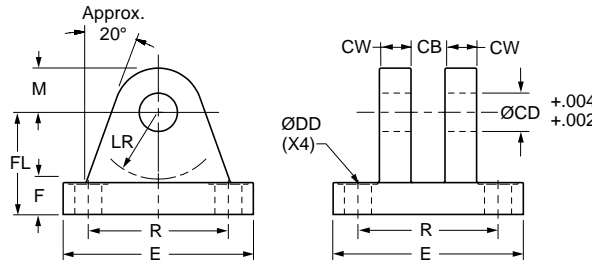

Cast or Forged Part Number ²	Pin Ø	CB	CD Ø	CW	DD Ø	E (As Cast)	F	FL	LR	M (As Cast)	R	For Use With B Mount Per Bore
0960160044	0.438	0.46	0.440	0.37	0.27	2.25	0.38	1.00	0.56	0.44	1.75	-
0960160050	0.500	0.78	0.503	0.50	0.41	2.50	0.38	1.13	0.63	0.56	1.63	1.50
0960160075	0.750	1.28	0.753	0.63	0.53	3.50	0.63	1.88	1.06	0.75	2.56	2.00, 2.50
0960160100	1.000	1.53	1.003	0.75	0.66	4.50	0.75	2.25	1.25	1.00	3.25	3.25
0960160138	1.375	2.03	1.378	1.00	0.66	5.00	0.88	3.00	1.94	1.38	3.81	4.00
0960160175	1.750	2.53	1.753	1.25	0.91	6.50	0.94	3.13	2.00	1.75	4.94	5.00
0960160200	2.000	2.53	2.003	1.25	1.06	7.50	1.38	3.75	2.25	2.00	5.75	6.00
0960160250	2.500	3.03	2.503	1.50	1.19	8.50	1.50	4.50	2.81	2.50	6.59	7.00
0960160300	3.000	3.03	3.003	1.50	1.31	9.50	1.88	5.38	3.31	3.00	7.50	8.00
0960160350	3.500	4.03	3.503	2.00	1.81	12.63	2.31	6.38	3.88	3.50	9.62	-
0960160400	4.000	4.53	4.003	2.25	2.06	14.88	2.88	7.50	4.50	4.00	11.50	-

² Clevis Brackets with pin diameters .438 thru 1.000 are forged steel. Clevis Brackets with 1.375 pin and larger are cast ductile iron.

Knuckle Dimensions

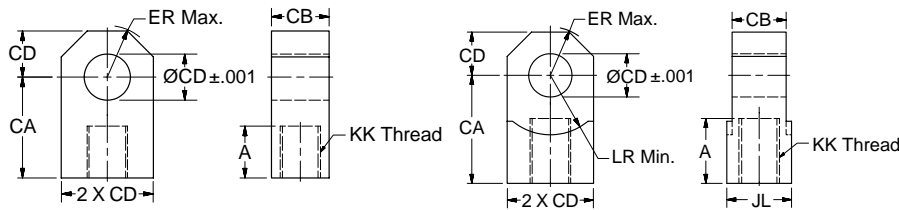

Thread Size thru 1 3/4-12

Thread Size 1 7/8-12 & Larger

Part Number	Pin Ø	A	CA	CB	CD Ø	ER	JL	LR min	KK Thread
0740750000	0.438	0.75	1.50	0.43	0.440	0.53	-	-	5/16-24
0690890000	0.500	0.75	1.50	0.75	0.503	0.59	-	-	7/16-20
0690900000	0.500	0.75	1.50	0.75	0.503	0.59	-	-	1/2-20
0690910000	0.750	1.13	2.06	1.25	0.753	0.87	-	-	3/4-16
0690920000	1.000	1.13	2.38	1.50	1.003	1.15	-	-	7/8-14
0690930000	1.000	1.63	2.81	1.50	1.003	1.15	-	-	1-14
0690940000	1.375	2.00	3.44	2.00	1.378	1.55	-	-	1 1/4-12
0690950000	1.750	2.25	4.00	2.50	1.753	1.96	-	-	1 1/2-12
0690960000	2.000	2.25	4.38	2.50	2.003	2.24	-	-	1 3/4-12
0962160000	2.000	3.00	5.00	2.50	2.003	2.24	3.00	2.77	1 7/8-12
0962170000	2.500	3.50	5.81	3.00	2.503	2.76	3.50	3.09	2 1/4-12
0962180000	3.000	3.50	6.13	3.00	3.003	3.30	4.00	3.58	2 1/2-12
0962190000	3.000	3.63	6.50	3.50	3.003	3.30	4.00	3.58	2 3/4-12
0962200000	3.500	4.50	7.63	4.00	3.503	3.87	6.00	4.18	3 1/4-12
0962210000	3.500	5.00	7.63	4.00	3.503	3.87	6.00	4.18	3 1/2-12
0962220000	4.000	5.50	9.13	4.50	4.003	4.43	6.00	4.80	4-12

Pivot Pin Dimensions

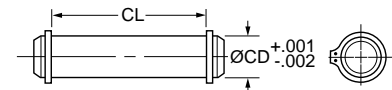

Part Number	CD Ø	CL
0740780000	0.438	1.31
0683680000	0.500	1.88
0683690000	0.750	2.63
0683700000	1.000	3.13
0683710000	1.375	4.19
0683720000	1.750	5.19
0692150000	2.000	5.69
0683740000	2.500	6.19
0683750000	3.000	6.25
0692160000	3.000	6.75
0735450000	3.500	8.25
0821810000	4.000	8.69
0735470000 ¹	4.000	9.00

¹ This size supplied with cotter pins.

Notes:

- Pivot Pins are furnished with Clevis Mounted Cylinders as standard.
- Pivot Pins are furnished with (2) Retainer Rings.
- Pivot Pins must be ordered as a separate item if to be used with Knuckles, Rod Clevises, or Clevis Brackets.

Fabricated Steel Clevis Bracket Dimensions

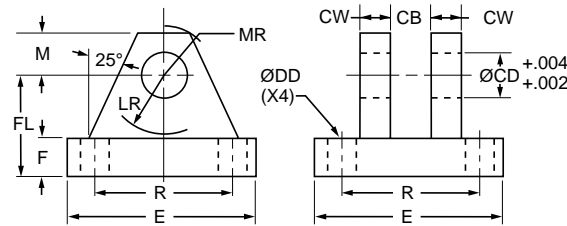

Fabricated Steel Part Number	Pin Ø	CB	CD Ø	CW	DD Ø	E	F	FL	LR	M	MR	R	For Use With B Mount Per Bore
0740760000	0.438	0.46	0.440	0.38	0.27	2.25	0.38	1.00	0.63	0.38	0.50	1.75	-
0692050000	0.500	0.80	0.503	0.50	0.41	3.50	0.50	1.50	0.75	0.50	0.63	2.55	1.50
0692060000	0.750	1.30	0.753	0.63	0.53	5.00	0.63	1.88	1.19	0.75	0.91	3.82	2.00, 2.50
0692070000	1.000	1.59	1.003	0.75	0.66	6.50	0.75	2.25	1.50	1.00	1.25	4.95	3.25
0692080000	1.375	2.09	1.378	1.00	0.66	7.50	0.88	3.00	2.00	1.38	1.66	5.73	4.00
0692090000	1.750	2.59	1.753	1.25	0.91	9.50	0.88	3.63	2.75	1.75	2.22	7.50	5.00
0692100000	2.000	2.59	2.003	1.50	1.06	12.75	1.00	4.25	3.19	2.25	2.78	9.40	6.00
0692110000	2.500	3.09	2.503	1.50	1.19	12.75	1.00	4.50	3.50	2.50	3.13	9.40	7.00
0692120000	3.000	3.09	3.003	1.50	1.31	12.75	1.00	6.00	4.25	3.00	3.59	9.40	8.00
0692130000	3.000	3.59	3.003	1.50	1.31	12.75	1.00	6.00	4.25	3.00	3.59	9.40	-
0735420000	3.500	4.09	3.503	2.00	1.81	15.50	1.69	6.69	5.00	3.50	4.13	12.00	-
0735430000	4.000	4.59	4.003	2.00	2.06	17.50	1.94	7.69	5.75	4.00	4.88	13.75	-

Accessories for spherical bearing mount cylinders include Spherical Rod Eyes, Pivot Pins and Clevis

Brackets. To identify the proper part number for the desired accessory, see the tables below.

**Spherical Rod Eye
(Inch Sizes)**

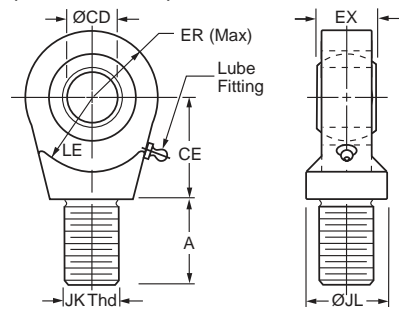

Note: Standard spherical bearing is maintenance-free (sealed) for CDØ > 0.5000"

Bore Ø	Part Number	A	CD Ø +.0000 -.0005	CE	ER	EX	JK Thread Size	JL Ø	LE	Load Capacity (lb)
1.50	0961000050	0.72	0.5000	0.86	0.80	0.44	7/16-20	0.88	0.78	2644
2.00	0961000075	1.02	0.7500	1.25	1.14	0.66	3/4-16	1.31	1.06	9441
2.50										
3.25	0961000100	1.52	1.0000	1.88	1.34	0.88	1-14	1.50	1.45	16860
4.00	0961000138	2.02	1.3750	2.13	1.67	1.19	1 1/4-12	2.00	1.91	28562
5.00	0961000175	2.14	1.7500	2.50	2.05	1.53	1 1/2-12	2.00	2.16	43005
6.00	0961000200	2.89	2.0000	2.75	2.60	1.75	1 7/8-12	2.75	2.50	70193

Order to fit Piston Rod Thread Size

Pivot Pin (Inch Sizes)

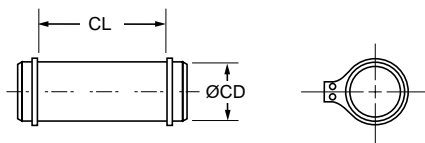

Pivot Pins are furnished with (2) Retainer Rings.

Bore Ø	Part Number	CD Ø	CL	Shear Capacity (lb)
1.50	0839620000	.4997 -.0004	1.56	8600
2.00	0839630000	.7497 -.0005	2.03	19300
2.50				
3.25	0839640000	.9997 -.0005	2.50	34300
4.00	0839650000	1.3746 -.0006	3.31	65000
5.00	0839660000	1.7496 -.0006	4.22	105200
6.00	0839670000	1.9996 -.0007	4.94	137400

Clevis Bracket for SB Mount Cap or Spherical Rod Eye (Inch Sizes)

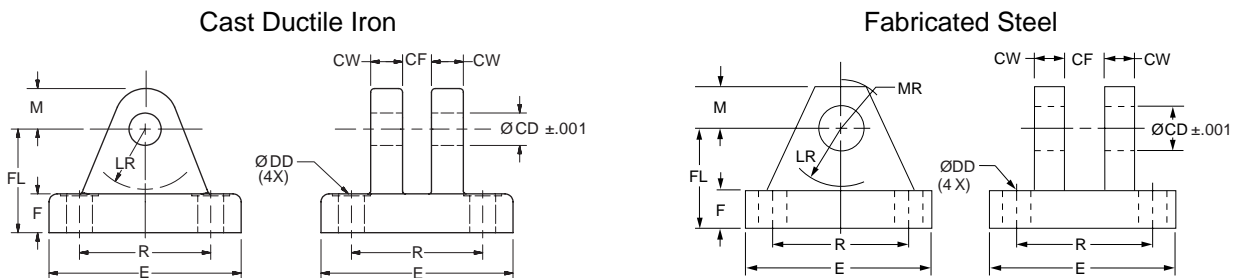

Bore Ø	Pin Ø	Cast Ductile Iron Part Number	Fabricated Steel Part Number	CD Ø	CF	CW	DD Ø	E	F	FL	LR	M	MR	R	Load Capacity (lb)
1.50	0.500	0959450000	0839470000	0.503	0.45	0.50	0.41	3.00	0.50	1.50	0.94	0.50	0.63	2.05	5770
2.00	0.750	0959300000	0839480000	0.753	0.67	0.63	0.53	3.75	0.63	2.00	1.38	0.88	1.00	2.76	9450
2.50															
3.25	1.000	0959310000	0839490000	1.003	0.89	0.75	0.53	5.50	0.75	2.50	1.69	1.00	1.19	4.10	14300
4.00	1.375	0959320000	0839500000	1.378	1.20	1.00	0.66	6.50	0.88	3.50	2.44	1.38	1.63	4.95	20322
5.00	1.750	0959330000	0839510000	1.753	1.55	1.25	0.91	8.50	1.25	4.50	2.88	1.75	2.06	6.58	37800
6.00	2.000	0959340000	0839520000	2.003	1.77	1.50	0.91	10.63	1.50	5.00	3.00	2.00	2.38	7.92	50375

Accessories for spherical bearing mount cylinders include Spherical Rod Eyes, Pivot Pins and Clevis

Brackets. To identify the proper part number for the desired accessory, see the tables below.

**Spherical Rod Eye
(Metric Sizes)**

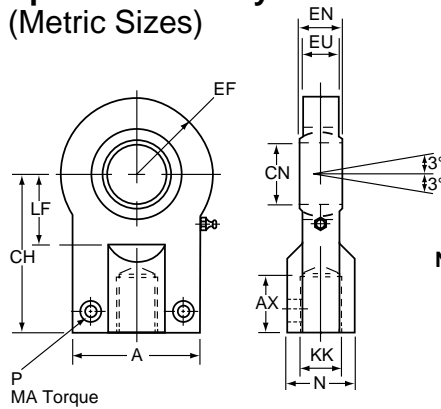

Note: Standard spherical bearing is maintenance-free (sealed)

Bore Ø (inches)	Part Number	A max	AX min	CH	CN	EF max	EN	EU	KK	LF min	MA max Nm	N max	P	Load Cap. (lb)
1.50	1452560000	55	19	58	20 -0.012	27.5	16 -.012	13	M14x1.5	25	25	25	M8	5301
2.00	1452570000	62	23	68	25 -0.012	32.5	20 -.012	17	M16x1.5	30	25	30	M8	9425
2.50	1452580000	80	29	85	30 -0.012	40	22 -.012	19	M20x1.5	35	45	36	M10	14726
3.25	1452590000	90	37	105	40 -0.012	50	28 -.012	23	M27x2	45	45	45	M10	24887
4.00	1452600000	105	46	130	50 -0.012	62.5	35 -.012	30	M33x2	58	80	55	M12	37699
5.00	1452610000	134	57	150	60 -0.015	80	44 -.015	38	M42x2	68	160	68	M16	58905
6.00	1452620000	156	64	185	80 -0.015	102.5	55 -.015	47	M48x2	92	310	90	M20	84823
7.00, 8.00	1452630000	190	86	240	100 -0.020	120	70 -.020	57	M64x3	116	530	110	M24	150796

Clevis Bracket and Pin for Style SBM Cap or Spherical Rod Eye (Metric Sizes)

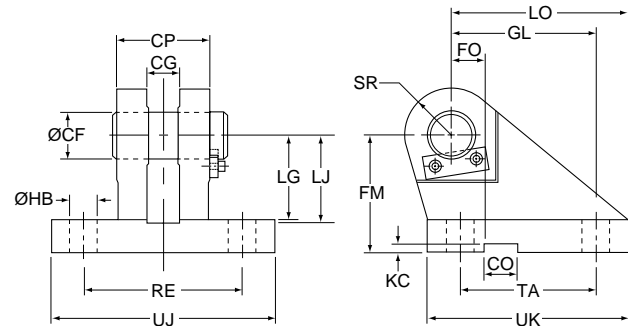

Bore Ø (inches)	Part Number	CF Ø K7/h6	CG +0.1, +0.3	CO N9	CP	FM js11	FO js14	GL js13	HB Ø	KC 0, +0.30	LG	LJ	LO	RE js13	SR max	TA js13	UJ	UK	Load Cap. (lb)
1.50	1455320000	20	16	16	50	55	20	64	14	4.3	39	40	80	85	20	58	120	90	4496
2.00	1455330000	25	20	25	60	65	22	78	16	5.4	48	49	98	100	25	70	140	110	7194
2.50	1455340000	30	22	25	70	85	24	97	18	5.4	62	63	120	115	30	90	160	135	11240
3.25	1455350000	40	28	36	80	100	24	123	22	8.4	72	73	148	135	40	120	190	170	17985
4.00	1455360000	50	35	36	100	125	35	155	30	8.4	90	92	190	170	50	145	240	215	28101
5.00	1455370000	60	44	50	120	150	35	187	39	11.4	108	110	225	200	60	185	270	260	44962
6.00	1455380000	80	55	50	160	190	35	255	45	11.4	140	142	295	240	80	260	320	340	71939
7.00, 8.00	1455390000	100	70	63	200	210	35	285	48	12.4	150	152	335	300	100	300	400	400	112404

All dimensions are in millimeters unless otherwise specified.

Linear Alignment Couplers are available in 19 standard thread sizes

Cost Saving Features and Benefits Include:

- Maximize reliability for trouble-free operation, long life and lower operating costs
- Increase cylinder life by reducing wear on piston and rod bearings
- Simplify cylinder installation and reduce assembly costs
- Lower maintenance costs from possible machine misalignment

Alignment Coupler

See Table for Part Numbers and Dimensions

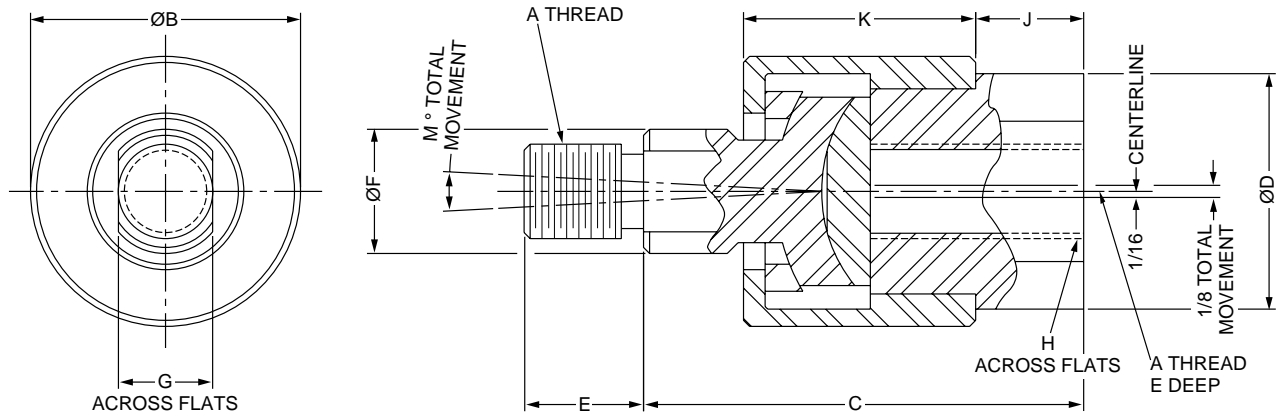

Part Numbers and Dimensions

Part Number	A ¹ Thread Size	B \varnothing	C	D \varnothing	E	F \varnothing	G	H	J	K	M	Max. Pull Load (lbs.)	Max. Approx. Weight (lbs.)
1347570031	5/16-24	1.13	1.75	0.94	0.50	0.50	0.38	0.75	0.38	0.94	6°	1200	.35
1347570038	3/8-24	1.13	1.75	0.94	0.50	0.50	0.38	0.75	0.38	0.94	6°	2425	.35
1347570044	7/16-20	1.38	2.00	1.13	0.75	0.63	0.50	0.88	0.38	1.09	6°	3250	.55
1347570050	1/2-20	1.38	2.00	1.13	0.75	0.63	0.50	0.88	0.38	1.09	6°	4450	.55
1347570063	5/8-18	1.38	2.00	1.13	0.75	0.63	0.50	0.88	0.38	1.09	6°	6800	.55
1347570075	3/4-16	2.00	2.31	1.63	1.13	0.94	0.75	1.31	0.44	1.28	6°	9050	1.4
1347570088	7/8-14	2.00	2.31	1.63	1.13	0.94	0.75	1.31	0.44	1.28	6°	14450	1.4
1347570100	1-14	3.13	3.00	2.38	1.63	1.44	1.25	1.88	0.75	1.78	6°	19425	4.8
1347570125	1 1/4-12	3.13	3.00	2.38	1.63	1.44	1.25	1.88	0.75	1.78	6°	30500	4.8
1337390125	1 1/4-12	3.50	4.00	2.00	2.00	1.50	1.25	1.69	0.75	2.50	10°	30500	6.9
1337390150	1 1/2-12	4.00	4.38	2.25	2.25	1.75	1.50	1.94	0.88	2.75	10°	45750	9.8
1337390175	1 3/4-12	4.00	4.38	2.25	2.25	1.75	1.50	1.94	0.88	2.75	10°	58350	9.8
1337390188	1 7/8-12	5.00	5.63	3.00	3.00	2.25	1.94	2.63	1.38	3.38	10°	67550	19.8
1337390200	2-12	5.00	5.63	3.00	3.00	2.25	1.94	2.63	1.38	3.38	10°	77450	19.8
1337390225	2 1/4-12	6.75	6.38	3.25	3.50	2.75	2.38	2.88	1.63	3.75	10°	99250	35.3
1337390250	2 1/2-12	7.00	6.50	4.00	3.50	3.25	2.88	3.38	1.63	3.88	10°	123750	45.3
1337390275	2 3/4-12	7.00	6.50	4.00	3.50	3.25	2.88	3.38	1.63	3.88	10°	150950	45.3
1337390300	3-12	7.00	6.50	4.00	3.50	3.25	2.88	3.38	1.63	3.88	10°	180850	45.3
1337390325	3 1/4-12	9.25	8.50	5.25	4.50	4.00	3.38	4.50	2.00	5.50	10°	218450	-
1337390425	4 1/4-12	12.88	11.25	7.75	4.50	5.50	4.88	7.00	1.50	8.75	10°	370850	-

¹ Metric thread size couplers are also available, consult factory.

How to Order Linear Alignment Couplers — When ordering a cylinder with a threaded male rod end, specify the coupler of equal thread size by part number as listed in the table. For example, Piston Rod “KK” or “CC” dimension is 3/4"-16, specify coupler part number 1347570075.

Style 55 Piston Rod End
Split Couplers and Weld Plates

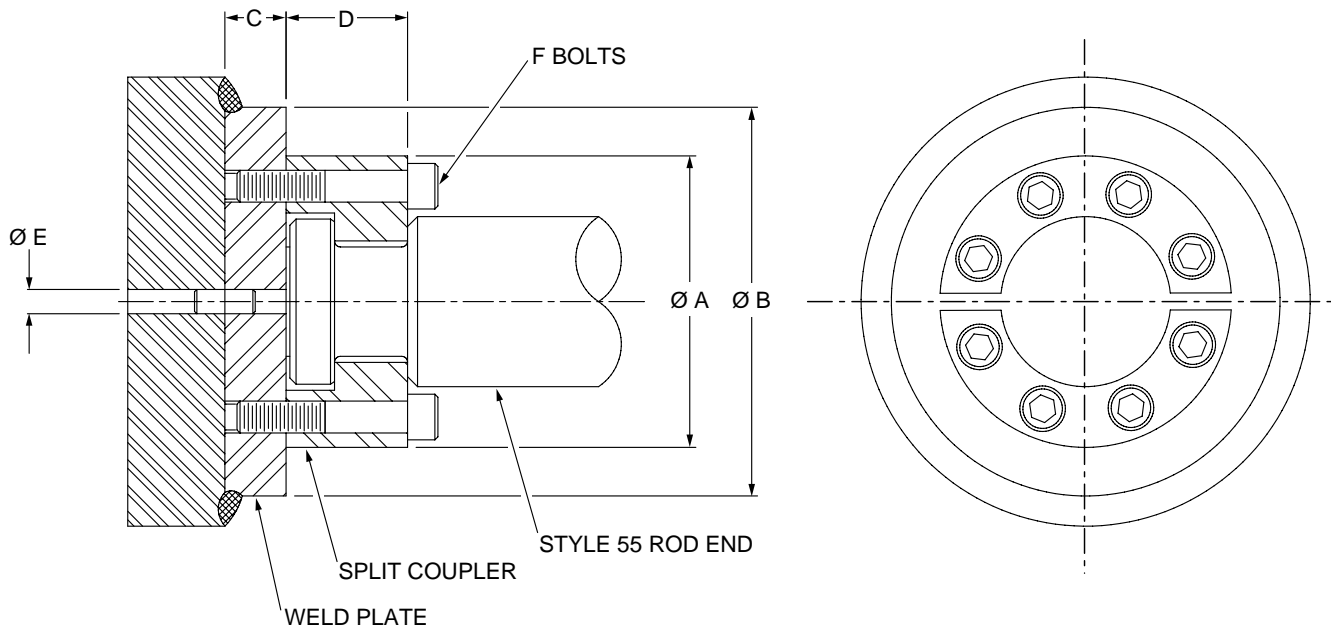

⚠ WARNING: Piston rod separation from the machine member can result in severe personal injury or even death to nearby personnel. The cylinder user must make sure the weld holding the weld plate to the machine is of sufficient quality and size to hold the intended load. The cylinder user must also make sure the bolts holding split coupler to the weld plate are of sufficient strength to hold the intended load and installed in such a way that they will not become loose during the machine's operation.

Part Numbers and Dimensions

Rod Ø	A Ø	B Ø	C	D	E Ø	F	Bolt Size	Bolt Circle	Split Coupler Part Number	Weld Plate Part Number
0.625	1.50	2.00	0.50	0.56	.250	4	#10-24 x .94 LG	1.125	1472340062	1481740062
1.000	2.00	2.50	0.50	0.88	.250	6	1/4-20 x 1.25 LG	1.500	1472340100	1481740100
1.375	2.50	3.00	0.63	1.00	.250	6	5/16-18 x 1.50 LG	2.000	1472340138	1481740138
1.750	3.00	4.00	0.63	1.25	.250	8	5/16-18 x 1.75 LG	2.375	1472340175	1481740175
2.000	3.50	4.00	0.75	1.63	.375	12	3/8-16 x 2.25 LG	2.687	1472340200	1481740200
2.500	4.00	4.50	0.75	1.88	.375	12	3/8-16 x 2.50 LG	3.187	1472340250	1481740250
3.000	5.00	5.50	1.00	2.38	.375	12	1/2-13 x 3.25 LG	4.000	1472340300	1481740300
3.500	5.88	7.00	1.00	2.63	.375	12	5/8-11 x 3.50 LG	4.687	1472340350	1481740350
4.000	6.38	7.00	1.00	2.63	.375	12	5/8-11 x 3.50 LG	5.187	1472340400	1481740400
4.500	6.88	8.00	1.00	3.13	.375	12	5/8-11 x 4.00 LG	5.687	1472340450	1481740450
5.000	7.38	8.00	1.00	3.13	.375	12	5/8-11 x 4.00 LG	6.187	1472340500	1481740500
5.500	8.25	9.00	1.25	3.88	.375	12	3/4-10 x 5.00 LG	6.875	1472340550	1481740550

Note: Bolts are not included with split coupler or weld plate

Parts Identification / Tools

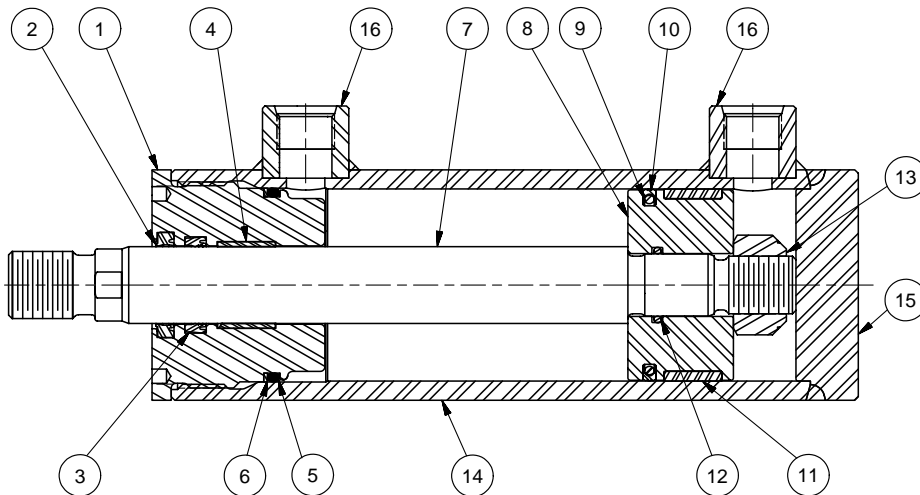

Cylinder Service Tool
(Head Torquing)

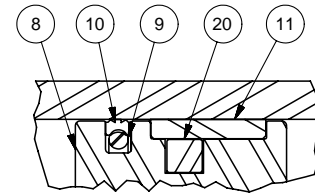

Optional
Magnetic Piston

Notes:

Factory assembled piston rod assemblies (which include seals for the specified piston type) are recommended. Do not remove the piston from the rod.

Cylinders rated for high temperatures (Seal Codes V, H and D) may include a set screw to lock the head to the cylinder body. Remove and replace it when servicing the cylinder.

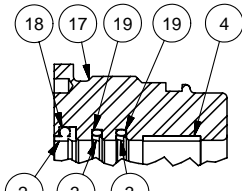

Optional Extreme High
Temperature and Low
Friction Head

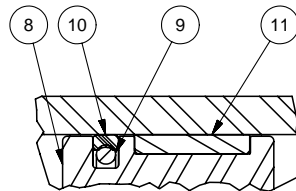

Optional Hi Load and
Low Friction Piston
(Bronze Filled PTFE Seal)

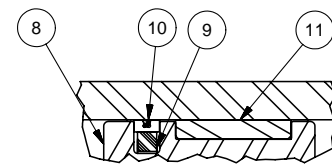

Optional Mixed
Media Piston

Parts Identification

Symbol	Description
1	Head
2	Rod wiper
3	Rod seal
4	Rod wear ring ¹
5	End seal (o-ring)
6	Backup ring for end seal
7	Piston rod (single rod type)
8	Piston
9	Piston seal energizer
10	Piston seal
11	Piston wear ring
12	Piston joint o-ring
13	Piston rod nut ²
14	Cylinder body (welded to cap)
15	Cap (welded to cylinder body)
16	Port (welded to cylinder body)
17	Head (optional) ³
18	Rod wiper energizer ^{3,4}
19	Rod seal energizer ³
20	Magnetic rings ⁵

Torque Tool Specifications

Spanner Hole Ø	Cylinder Service Tool	Head Torque Units	
		USA Lb-Ft	Metric N-m
2 holes on head face	Fits standard square drive on torque wrench		
0.171	RDHSVCTL15	55	75
0.203	RDHSVCTL20	70	95
0.203	RDHSVCTL25	100	136
0.266	RDHSVCTL32	150	203
0.266	RDHSVCTL40	175	237
0.266	RDHSVCTL50	225	305
0.266	RDHSVCTL60	285	386
0.391	RDHSVCTL70	400	542
0.516	RDHSVCTL80	485	658

¹ Not used for 0.625" rod diameter

² Only for 1.50" to 5.00" bores. For 6.00" to 8.00" bores, pistons are threaded and torqued to the piston rod, and set screws are used to lock the piston to the rod.

³ Used for Piston code F or Seal code H

⁴ Used for Seal codes M and D

⁵ Used for Piston code 7

Piston Seal Kits

Seal Class	Piston Code	Bore Diameter				
		1.50	2.00	2.50	3.25	4.00
1	B, 7	PK151RDH01	PK201RDH01	PK251RDH01	PK321RDH01	PK401RDH01
1	K, F	PK151RDHK1	PK201RDHK1	PK251RDHK1	PK321RDHK1	PK401RDHK1
1	W	PK151RDHW1	PK201RDHW1	PK251RDHW1	PK321RDHW1	PK401RDHW1
2	B, K, F, 7	PK151RDH02	PK201RDH02	PK251RDH02	PK321RDH02	PK401RDH02
3	B, K, F, 7	PK151RDH03	PK201RDH03	PK251RDH03	PK321RDH03	PK401RDH03
4	B, 7	PK151RDH04	PK201RDH04	PK251RDH04	PK321RDH04	PK401RDH04
4	K, F	PK151RDHK5	PK201RDHK5	PK251RDHK5	PK321RDHK5	PK401RDHK5
4	W	PK151RDHW4	PK201RDHW4	PK251RDHW4	PK321RDHW4	PK401RDHW4
5	B, K, F, 7	PK151RDH05	PK201RDH05	PK251RDH05	PK321RDH05	PK401RDH05
5	W	PK151RDHW5	PK201RDHW5	PK251RDHW5	PK321RDHW5	PK401RDHW5
8	B, F, K	PK151RDH08	PK201RDH08	PK251RDH08	PK321RDH08	PK401RDH08

Seal Class	Piston Code	Bore Diameter			
		5.00	6.00	7.00	8.00
1	B, 7	PK501RDH01	PK601RDH01	PK701RDH01	PK801RDH01
1	K, F	PK501RDHK1	PK601RDHK1	PK701RDHK1	PK801RDHK1
1	W	PK501RDHW1	PK601RDHW1	PK701RDHW1	PK801RDHW1
2	B, K, F, 7	PK501RDH02	PK601RDH02	PK701RDH02	PK801RDH02
3	B, K, F, 7	PK501RDH03	PK601RDH03	PK701RDH03	PK801RDH03
4	B, 7	PK501RDH04	PK601RDH04	PK701RDH04	PK801RDH04
4	K, F	PK501RDHK5	PK601RDHK5	PK701RDHK5	PK801RDHK5
4	W	PK501RDHW4	PK601RDHW4	PK701RDHW4	PK801RDHW4
5	B, K, F, 7	PK501RDH05	PK601RDH05	PK701RDH05	PK801RDH05
5	W	PK501RDHW5	PK601RDHW5	PK701RDHW5	PK801RDHW5
8	B, F, K	PK501RDH08	PK601RDH08	PK701RDH08	PK801RDH08

Rod Seal Kits

Seal Class	Piston Rod Diameter					
	0.625	1.000	1.375	1.750	2.000	2.500
Class 1	RKRDH00061	RKRDH00101	RKRDH00131	RKRDH00171	RKRDH00201	RKRDH00251
Class 2	RKRDH00062	RKRDH00102	RKRDH00132	RKRDH00172	RKRDH00202	RKRDH00252
Class 3	RKRDH00063	RKRDH00103	RKRDH00133	RKRDH00173	RKRDH00203	RKRDH00253
Class 4	RKRDH00064	RKRDH00104	RKRDH00134	RKRDH00174	RKRDH00204	RKRDH00254
Class 5	RKRDH00065	RKRDH00105	RKRDH00135	RKRDH00175	RKRDH00205	RKRDH00255
Class 8	N/A	RKRDH00108	RKRDH00138	RKRDH00178	RKRDH00208	RKRDH00258
Class 1 (Low Friction)	N/A	RKRDHF0101	RKRDHF0131	RKRDHF0171	RKRDHF0201	RKRDHF0251
Class 5 (Low Friction)	N/A	RKRDHF0105	RKRDHF0135	RKRDHF0175	RKRDHF0205	RKRDHF0255
Class 1 (Metallic Scrapper)	RKRDHM0061	RKRDHM0101	RKRDHM0131	RKRDHM0171	RKRDHM0201	RKRDHM0251
Class 5 (Metallic Scrapper)	RKRDHM0065	RKRDHM0105	RKRDHM0135	RKRDHM0175	RKRDHM0205	RKRDHM0255

Seal Class	Piston Rod Diameter					
	3.000	3.500	4.000	4.500	5.000	5.500
Class 1	RKRDH00301	RKRDH00351	RKRDH00401	RKRDH00451	RKRDH00501	RKRDH00551
Class 2	RKRDH00302	RKRDH00352	RKRDH00402	RKRDH00452	RKRDH00502	RKRDH00552
Class 3	RKRDH00303	RKRDH00353	RKRDH00403	RKRDH00453	RKRDH00503	RKRDH00553
Class 4	RKRDH00304	RKRDH00354	RKRDH00404	RKRDH00454	RKRDH00504	RKRDH00554
Class 5	RKRDH00305	RKRDH00355	RKRDH00405	RKRDH00455	RKRDH00505	RKRDH00555
Class 8	RKRDH00308	RKRDH00358	RKRDH00408	RKRDH00458	RKRDH00508	RKRDH00558
Class 1 (Low Friction)	RKRDHF0301	RKRDHF0351	RKRDHF0401	RKRDHF0451	RKRDHF0501	RKRDHF0551
Class 5 (Low Friction)	RKRDHF0305	RKRDHF0355	RKRDHF0405	RKRDHF0455	RKRDHF0505	RKRDHF0555
Class 1 (Metallic Scrapper)	RKRDHM0301	RKRDHM0351	RKRDHM0401	RKRDHM0451	RKRDHM0501	RKRDHM0551
Class 5 (Metallic Scrapper)	RKRDHM0305	RKRDHM0355	RKRDHM0405	RKRDHM0455	RKRDHM0505	RKRDHM0555

Water Submersible Option

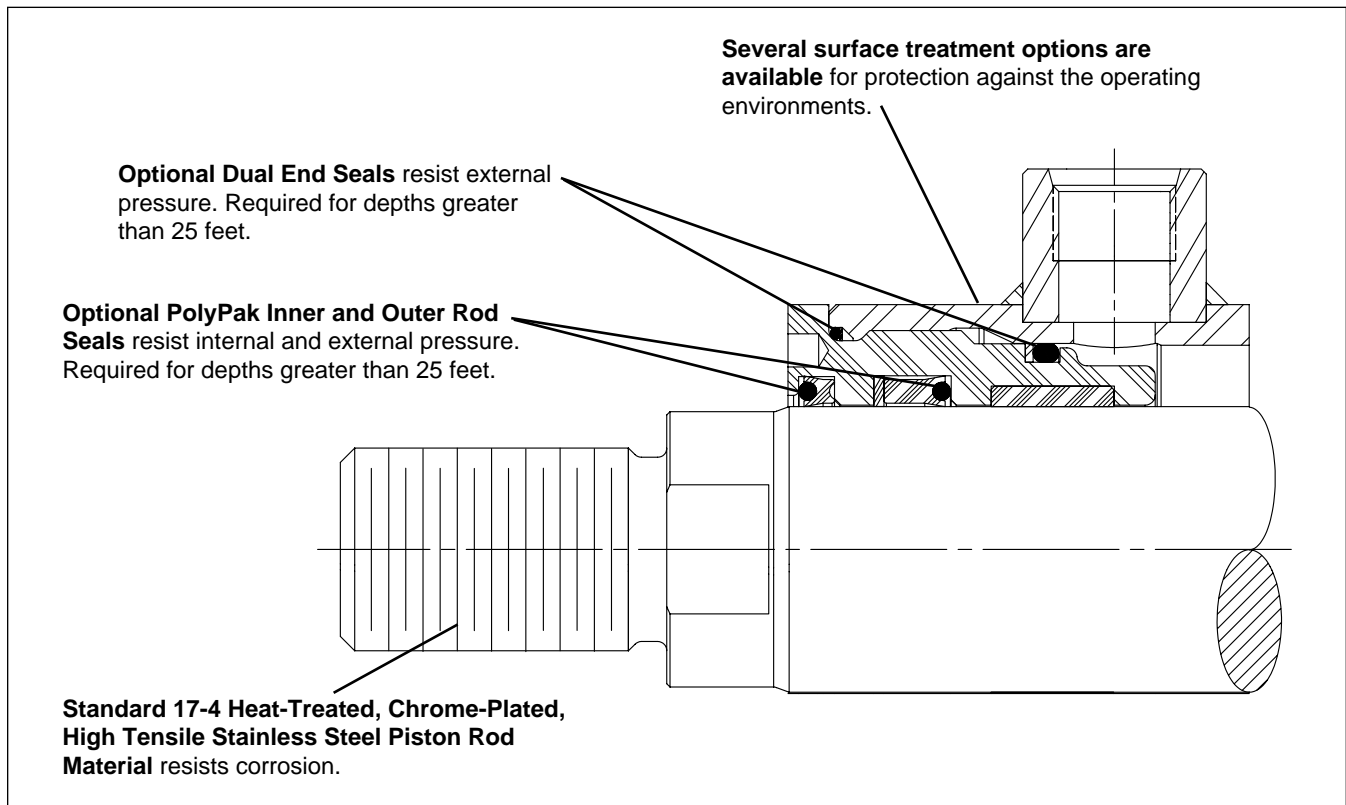

Specifications:

- Submersion Depth – to 15,000 feet
- Nominal Pressure – 3,000 psi
- Operating Temperature – -10°F to +165°F
- 17-4 PH chrome plated stainless steel piston rod
- Stainless steel nametag

Cylinder Seal Construction:

- 0 to 25 feet depth – Standard rod seal and end seals
- 25 to 5,000 feet depth
 - Subsea rod seal package that includes a PolyPak oil seal and an outward-facing PolyPak wiper to seal against water intrusion.
 - Subsea end seal package with ID oil seal and body-end o-ring to seal against water intrusion.
- Over 5,000 feet depth – consult factory for details

Standard Options for Water Submersible Cylinders:

Material

- Chrome plated cylinder body ID

Surface Treatments for Corrosion Protection

- Electroless nickel plated exterior (head, cap and cylinder body)
- Inorganic zinc primer (zinc primer only – without bond coating)
- Inorganic zinc primer with epoxy undercoat and polyurethane or acrylic epoxy topcoat
- Epoxy undercoat and topcoat

Custom Options available for Special Order:

- All stainless steel construction



How to Order Water Submersible Option

Water Submersible Option

How to order:

1. Specify the complete cylinder model number.
2. Put an "S" in the model number to indicate a Special Modification.
3. Include the 3 digit "Submersible Code" (see below).
4. For custom options, provide a complete description or drawing of your requirements.

Submersible Code

When selecting the submersible option, an S must be placed in the Model Number. Select Submersible Code values for the required Submersion Depth, Cylinder Body, and Corrosion Protection. See the example Model Number below:

Feature	Code	Specification	For
Submersion Depth	1	Conventional rod seal, rod wiper and end seal	Depths to 25 feet
	2	Submersible rod seal, rod wiper and end seal	Depths to 5,000 feet
	3	Other	Specify depth / requirements
Cylinder Body	P	Plain cylinder body ID	
	C	Chrome plated cylinder body ID	
Corrosion Protection	1	Inorganic zinc primer	Splash and short term immersion service where equipment is top coated by the customer
	3	Electroless nickel plated exterior	
	4	Inorganic zinc primer, epoxy undercoat, and polyurethane or acrylic epoxy topcoat.	Splash and short term immersion service
	6	Epoxy base and top coat.	Long term immersion service
	9	Other	Specify requirements

Example:

4.00BBRDHKTS14A24.000

S = Submersible Code 2P1

(describes a 4" bore x 24" stroke Series RDH cylinder for submersion up to 5,000 feet, with a plain cylinder body ID and inorganic zinc primer corrosion protection.)

Water Submersible Codes and Features Supplied

Depths to 5,000 feet¹

Submersible Cylinder Feature	Water Submersible Code ¹							
	2P1	2P3	2P4	2P6	2C1	2C3	2C4	2C6
17-4 PH stainless steel piston rod	X	X	X	X	X	X	X	X
Stainless steel nametag	X	X	X	X	X	X	X	X
Submersible rod seal and wiper	X	X	X	X	X	X	X	X
Dual end seals	X	X	X	X	X	X	X	X
Chrome plated cylinder body ID					X	X	X	X
Electroless nickel plated exterior		X				X		
Inorganic zinc primer	X				X			
Inorganic zinc primer with topcoats			X				X	
Epoxy base and topcoat				X				X

¹ Corresponding submersible codes for depths to 25 feet begin with 1 (e.g. 1P1, 1P3, etc.) and include all of the features marked for 5,000 feet depth **except** Submersible Rod Seal, Rod Wiper and End Seals.

The Exclusive Hi Load Piston

The effective difference... bronze filled PTFE ring design.

- Virtually eliminates leakage
- High load capacity
- High contamination tolerance
- Long life
- Low friction

The revolutionary Hi Load piston assembly was designed to increase and insure consistent quality performance of the piston seals and your equipment. It's a major innovative refinement over typical cast iron piston rings and nitrile or fluorocarbon lipseals.

The Hi Load piston assembly overcomes the inherent problems commonly associated with these conventional types of seals, such as scoring of the cylinder bore due to contamination, and it virtually eliminates leakage flow. It can also reduce or eliminate the need for stop tubing. It has much greater side load carrying capacity, and most importantly, even at pressures up to 3,000 psi, it has a longer wearing life than any seal that we have tested to date.

The Hi Load piston assembly is comprised of a bronze filled PTFE piston seal (with a nitrile energizer) and a WearGard™ non-metallic wear ring to achieve dramatic efficiency.

Reduced scoring. Low friction. The WearGard™ non-metallic wear ring eliminates all metal-to-metal contact between the piston and cylinder body. Some scoring may occur even with the use of compatible materials such as cast iron or bronze for the piston and steel for the cylinder body. The combination of the high imbeddability factor and the wiping action of the wear ring prevents contamination from getting between the piston bearing and sealing surfaces; therefore, scoring is greatly reduced and cylinder life is extended. Other benefits of the Hi Load piston are excellent lubricity and minimum wear when using water base fluids, soluble oil & water, or biodegradable fluids.

Extensive controlled contamination tests in our laboratory have shown the Hi Load piston to operate more than **4 times longer** than lip seals when high degrees of contamination are present.

Note: Because the Hi Load piston prevents metal-to-metal contact with the cylinder bore, steel pistons may be used.

Higher side load carrying capacity. Under severe side load conditions arising from long stroke or pivot mounted cylinders, the characteristics of a non-metallic wear ring provide increased side load carrying capability, a distinctive benefit. The non-metallic bearing can also absorb hydraulic shock and conform more to the piston and cylinder body. The action of deformation increases the area of contact, which in turn keeps the contact stresses from increasing and permits the Hi Load piston to have a higher side load carrying capacity. This can often reduce or eliminate the need for stop tubing.

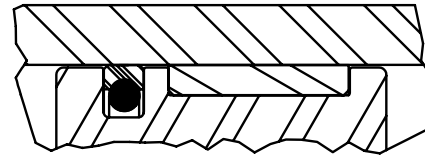

Optional Hi Load Piston

Virtually zero leakage. The Hi Load piston assembly provides virtually zero leakage with hydraulic and/or water base fluids due to the continuous bronze filled PTFE ring with a homogenous inner ring of Nitrile rubber to apply seal preloading. The Nitrile energizer provide enough initial radial force to eliminate low pressure leakage. At higher pressure (above 2,000 psi) the seal is also pressurized underneath, and is therefore dynamically self-sealing.

The bronze filled PTFE resists extrusion in the clearance between the piston and bore much better than Nitrile, and, as a result, increases the life of a cylinder, significantly at higher pressures.

When ordering the Hi Load piston option for Series RDH cylinders, specify K in the Piston field of the model code.

Comparative Piston Seal Friction

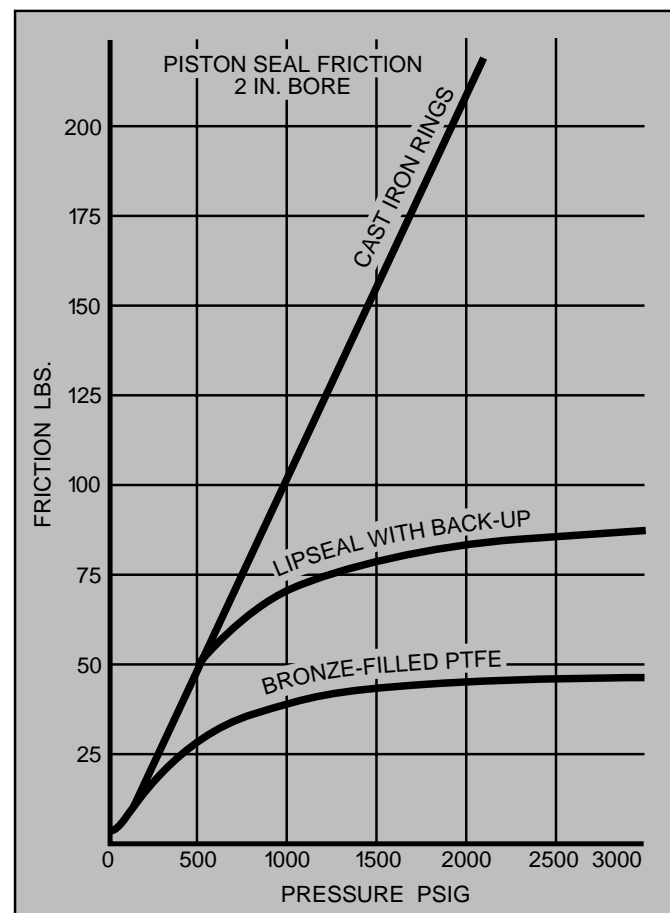

Low Friction Seal Option

- Smooth-running operation – reduces “stick/slip” or “chatter”
- Bronze filled PTFE seals and WearGard™ wear rings for low friction, rapid break-in and long service life

- Appropriate for servo applications
- Innovative seal geometry for maximum sealing efficiency
- When ordering Series RDH cylinders, place an “F” in the Piston field for Low Friction Seals.

Low Friction Rod Seal Design

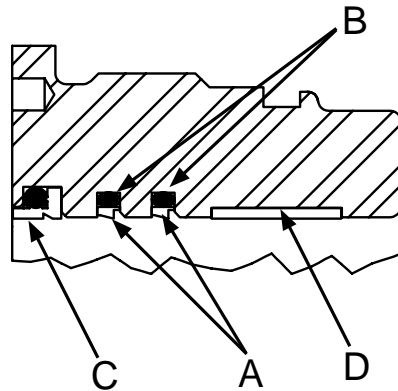

- A** - Dual bronze filled PTFE step-seal rod seals insure positive sealing and smooth operation at low or high pressures.
- B** - Elastomer expander for pressure compensation and low pressure effectiveness.
- C** - Durable, energized bronze filled PTFE lip wiper keeps contaminants out.
- D** - WearGard™ wear ring for high load capacity, low friction and no metal-to-metal contact.

Available for all standard piston rod diameters larger than 0.625"

Low Friction Piston Seal Design

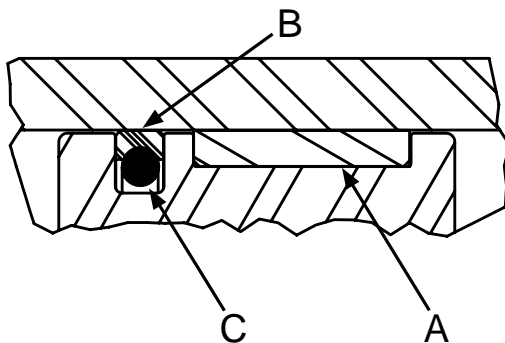

- A** - WearGard™ wear ring for high load capacity, low friction and no metal-to-metal contact.
- B** - Bronze filled PTFE piston seal ensures maximum sealing efficiency.
- C** - Elastomer expander for pressure compensation and low pressure effectiveness.

Available for all standard bore diameters.

Seal Friction

Seal friction under a given set of working conditions is not easily calculated due to the multiplicity of variables involved. The following graph is offered as a guide for use in performance calculations, but for critical applications, measurements should be made under simulated or actual working conditions.

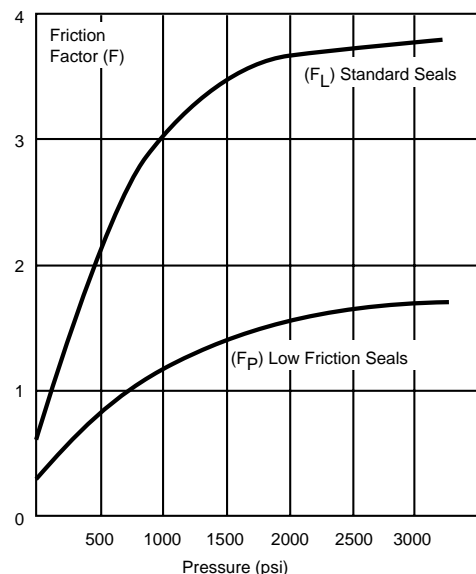

Calculation of Running Friction

The seal friction attributable to the cylinder is calculated as the sum of the friction due to the individual sealing elements (wiperseal friction + rod seal friction + piston seal friction), using the following formulae:

Option:	Formula:
Standard rod and piston seals	$12d + 12 F_L d + 24 F_L D$
Low friction rod and piston seals	$12d + 30 F_p d + 6 F_p D$

Where: d = rod dia. (inch) D = bore dia. (inch)

F_L = friction factor for standard seals (F_L)

F_p = friction factor for PTFE low friction seals (F_p)

Breakaway Friction

Breakaway friction may be calculated by applying the following correction factors:

Correction factors –

Standard seals: $F_L \times 1.5$

Low friction seals: $F_p \times 1.0$

Sample Calculation

Series RDH Cylinder with 3.25 dia. bore and 1.75 dia. piston rod with low friction seals at 1500 psi.

Running Friction Calculation:

$$\text{Friction (lbs. force)} \approx 12d + 30F_p d + 6F_p D$$

$$\text{Friction (lbs. force)} \approx 12 (1.75) + 30 (1.3 \times 1.75) + 6 (1.3 \times 3.25)$$

$$\text{Friction (lbs. force)} \approx 115$$

Breakaway Friction Calculation:

$$F_p \times 1.0 \approx F_p$$

Based on zero pressure:

$$\text{Friction (lbs. force)} \approx 12d + 30F_p d + 6F_p D$$

$$\text{Friction (lbs. force)} \approx 12 (1.75) + 30 (.3 \times 1.75) + 6 (.3 \times 3.25)$$

$$\text{Friction (lbs. force)} \approx 43$$

Specifications for Low Friction Options:

Operating Pressure: 0 - 3000 psi

Operating Temperature: -10°F to +165°F.

For higher temperatures, consult factory.

Fluid Media: petroleum-based hydraulic oils.

For other fluids, consult factory.

The following modifications can be supplied on most Series RDH cylinders for an additional charge.

Metallic Rod Wiper

When specified, metallic rod wipers can be supplied instead of the standard urethane wiperseal. Recommended in applications where contaminants tend to cling to the extended piston rod and would damage the standard urethane wiperseal. Installation of metallic rod wiper does not affect cylinder dimensions.

Air Bleeds

In most hydraulic circuits, cylinders are considered self-bleeding when cycled full stroke. If air bleeds are required and specified, Air Bleed Ports for venting air can be provided at both ends of the cylinder body, or on the head or cap. To order, specify "Bleed Port" and indicate the desired position on the cylinder.

Rod End Boots

Cylinders have a hardened bearing surface on the piston rod to resist external damage and are equipped with the high efficiency "wiperseal" to remove external dust and dirt. Exposed piston rods that are subjected to contaminants with air hardening properties, such as paint, should be protected. In such applications, the use of a collapsing cover should be considered. This is commonly referred to as a "rod boot". Calculate the longer rod end required to accommodate the collapsed length of the boot from the following data.

LF	.13	.13	.13	.13	.13	.13	.13	.10	.10	.10	.10	.10
OD	2.25	2.25	2.63	3.00	3.38	3.75	4.38	5.13	5.63	6.25	7.00	7.50
MM	.500	.625	1.000	1.380	1.750	2.000	2.500	3.000	3.500	4.000	5.000	5.500

To determine extra length of piston rod required to accommodate boot, calculate:
 $BL = \text{Stroke} \times LF + 1.13"$
 $BL + W + A = \text{length of piston rod to extend beyond the head face.}$
Note: Check all Boot O.D's against "E" dimension from catalog.

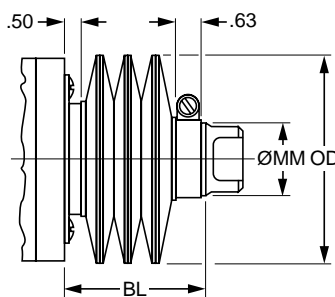

Stroke Adjusters

For the requirement where adjusting the stroke is specified. Several designs are available.

A "retracting stroke adjuster" must be ordered with an S for Special Modification in the model code, and the length of the adjustment must be specified.

"Infrequent-type" is defined by positioning the retract stroke in a couple of attempts at original machine set up. The "frequent-type" stroke adjuster is recommended for adjustments required after the equipment has been adjusted by the original machine manufacturer.

Metric Piston Rod Thread

The table below lists the standard thread supplied when Piston Rod Thread Type M is specified in the cylinder model code with Piston Rod Ends 4, 8 and 9. For Style 7M, see page 15 for details.

MM Rod Ø (inches)	Thread Size		A Thread Length (inches)
	Styles 4M & 9M KK	Style 8M CC	
0.625	M10x1.5	M12x1.5	0.75
1.000	M20x1.5	M22x1.5	1.13
1.375	M26x1.5	M30x2	1.63
1.750	M33x2	M39x2	2.00
2.000	M39x2	M45x2	2.25
2.500	M48x2	M56x2	3.00
3.000	M58x2	M68x2	3.50
3.500	M64x2	M76x2	3.50
4.000	M76x2	M95x2	4.00
4.500	M80x2	M110x2	4.50
5.000	M90x2	M110x2	5.00
5.500	M100x2	M130x2	5.50

Rectangular Head and Cap Flanges

Rectangular head flanges and cap flanges that match-mount NFPA Style ME5 and ME6 are available as a special modification. Enter "S" for Special Modification in the cylinder model code, request the desired flange in the item notes and consult the factory for a quote.

Welded Rod End Accessories

Some standard and special rod end accessories can be welded to the piston rod. In the cylinder model code, specify "3" in the Piston Rod Thread Style field (for special rod end). Then describe the accessory in the item notes (or furnish a dimensioned sketch), signify that it is welded to the piston rod and consult the factory for a quote.

Additional common and custom modifications are available, see Custom Options and Modifications page or consult the factory.

Switches Mounted on Series RDH Cylinders Add Value to Your Machine Design

- Switches and cylinder combine to form a compact package
- Body-mounted switches are easily adjustable along cylinder stroke length
- Low profile switches are less prone to mechanical damage
- Non-intrusive design eliminates the possibility of oil leakage
- Utilizes the standard carbon steel cylinder body

Series RDH Cylinder – with magnetic piston

Durable polyurethane bi-directional seal – for positive sealing with no by-pass and long life.

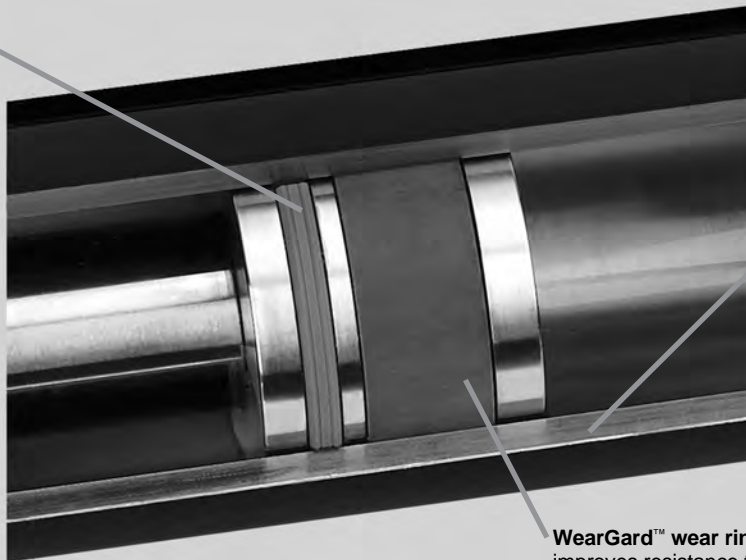

Cylinder Body – Standard carbon steel material for ALS Switch.

WearGard™ wear ring – improves resistance to bearing loads and provides support for magnet.

C

ALS Switch Wiring and Installation

- For magnetic piston sensing through steel tube material
- 4 wire DC connection
- PNP and NPN versions can be wired N.O. or N.C.

Switch Operation

The switch detects a change in polarity of the magnetic field as a piston with magnet moves through the cylinder.

Formatting

Before the switch is used for the first time, the piston with magnet should be run in and out of the cylinder to format the cylinder tube. The switch will detect the polarity of the residual magnetic field created by the movement of the magnetic piston during formatting.

Field Direction with Magnetic Piston

Single rod end cylinders are assembled with the piston magnet's North Pole facing the rod end. As the magnetic piston moves through the cylinder, it creates a stronger field opposite in polarity to the residual magnetism in the cylinder tube. As it moves under the switch, the change in polarity of the magnetic field in the cylinder tube is detected.

Switch Zone

Switch actuation occurs as the piston enters a switching "zone". The switching point is highly repeatable, in either direction, under conditions of constant piston speed and operating temperature.

Note: ALS Switches are designed to sense near end of stroke positions ("stroke-to-go") and stroke positions in between these two points. For true end-of-stroke position sensing, use the CLS-A or EPS-A Limit Switches featured on the EPS-A Sensors / CLS-A Switches page.

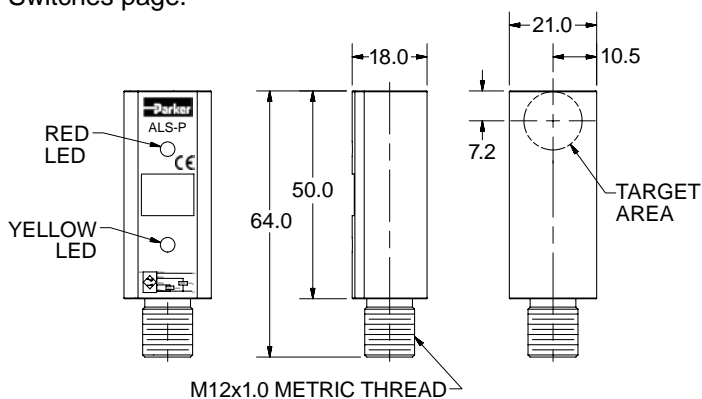

ALS Switch output states may be influenced by an external magnetic field. Care must be taken to avoid external magnetic field exposure.

- The ALS Switch is not designed for use with non-ferrous tubes
- CE approved
- ATEX approved version available

The switching zone may be up to 21mm wide depending on tube wall thickness and piston speed.

LED Indicators

There are two LED's (yellow and red) to indicate that the piston is inside or outside the switching zone. The sequence of the LED's is determined by the orientation of the north pole of the magnet system (rod end side of single rod end cylinders) to the connector.

When the ALS Switch connector faces the rod side of single rod end cylinders the red LED turns ON when the piston is within the switching zone. The yellow LED is ON otherwise.

When the ALS Switch connector faces the cap side of single rod end cylinders the yellow LED turns ON when the piston is within the switching zone. The red LED is ON otherwise.

Performance

ALS Switches have been designed to operate at a maximum piston speed of 0.5m/s, and a maximum cylinder operating temperature of 85°C.

Specifications

Switching Output:	PNP or NPN
Hysteresis¹:	5mm
Repeatability¹:	0.5mm
Load Current:	100mA
Leakage Current:	≤ 10μA
Voltage Drop:	≤ 1.5 VDC
Short Circuit and Overload Protection:	Yes
Reverse Polarity Protection:	Yes
Supply Voltage:	10 - 30 VDC
LED(s):	Yes (2)
Current Consumption:	≤ 30 mA
Operating Temperature Range:	-25°C to +85°C (-13°F to +185°F)
Housing Material:	Black Polyamide (PA)
Enclosure Rating:	IP67

¹Hysteresis and repeatability based on measurements with a cylinder outer diameter of 46mm, wall thickness of 3mm and piston speed of 0.5m/s.

ALS Switch Wiring and Installation

Because the ALS Switch detects change in polarity as the magnet moves through the cylinder, wiring connections are dependent on switch mounting orientation to the magnet's North Pole. The two possible orientations are:

- A – connector facing toward the rod end (rod end 1 if K-type)
- B – connector facing toward the cap end (rod end 2 if K-type)

Connections to Pin 1 (+VDC) and Pin 3 (-VDC) are the same for either switch orientation. But, as outlined in the table and wiring schematic diagrams below, the normal output state of Pins 2 & 4 flip between mounting orientations A & B. Note that to sense near the fully retracted position of the cylinder the cap end switch must be mounted in orientation A, and to sense near the fully extended position of the cylinder the rod end switch must be mounted in orientation B.

General view of switches as installed:

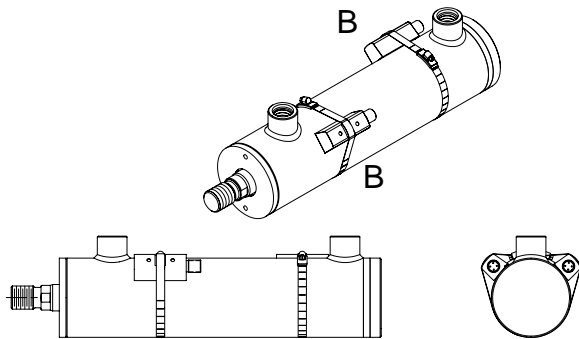

Example: An application requires that ALS Switches sense two positions of the cylinder with normally closed logic at both ends. How would the switches be wired?

Answer: The two switches would not be installed or wired the same way. The cap end switch would be installed in orientation A with Pin 1 (+VDC), Pin 2 (Load), Pin 3 (-VDC), Pin 4 (not used). The rod end switch would be installed in orientation B with Pin 1 (+VDC), Pin 2 (not used), Pin 3 (-VDC), Pin 4 (Load).

LED Function and Pin Wiring

Switch Mounting Orientation	Connector Facing Toward		LED indicator (on/off) when magnet is:				Pin	Wire	Function
	Single Rod Cylinder	Double Rod Cylinder	Out of Switch Zone		In Switch Zone				
			Red	Yellow	Red	Yellow			
A	Rod End	Rod End #1	off	on	on	off	1	Brown	+VDC
			off	on	on	off	2	White	N.C.
			off	on	on	off	3	Blue	-VDC
			off	on	on	off	4	Black	N.O.
B	Cap End	Rod End #2	on	off	off	on	1	Brown	+VDC
			on	off	off	on	2	White	N.O.
			on	off	off	on	3	Blue	-VDC
			on	off	off	on	4	Black	N.C.

PNP

Switch Orientation A

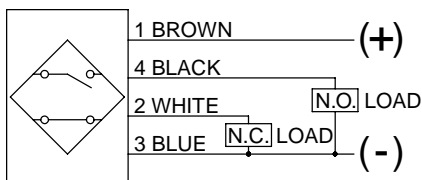

Switch Orientation B

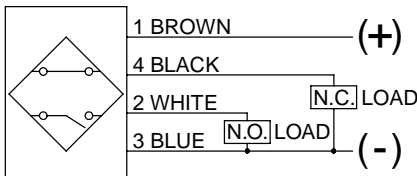

**ALS Switch – Wiring Connection
12mm Connector**

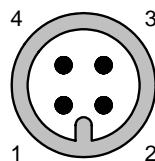

NPN

Switch Orientation A

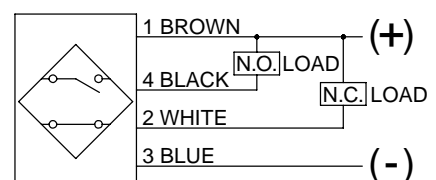

Switch Orientation B

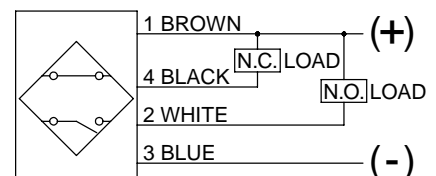

ALS Switch and Accessory Part Numbers

All switches have a 4-pin male M12x1 threaded connector.

Body mounting band for ALS switches must be ordered separately.

Switch Part Number	
PNP	NPN
0944520000	0942230000

Note: Specify piston code '7' in cylinder model number when using ALS Switches.

Body Mounting Band Part Number	
Bore Ø	Part Number
1.50	0965360150
2.00	0965360200
2.50	0965360250
3.25	0965360325
4.00	0965360400
5.00	0965360500
6.00	0965630600

Minimum Net Stroke for ALS Switch

Bore Ø	Stroke
1.50	3.00
2.00	3.00
2.50	2.88
3.25	2.75
4.00	2.63
5.00	2.38
6.00	2.19

12mm Cordset for ALS Switches

12mm Cordset with Female Quick Connect

M12 Straight Connector	
Cable Length	Part Number
5 meters	9126487205
2 meters	9126487202

M12 Right Angle Connector	
Cable Length	Part Number
5 meters	9126487305
2 meters	9126487302

A female connector is available for all switches with the male 12mm quick connect option. The cordsets are available with a right angle or straight connector. Cordset part numbers are listed above.

Cordset Specifications

- Connector..... Polyvinylchloride (PVC) body material, PVC contact carrier, spacing to VDE 0110 Group C, (250VAC / 300VDC)
- Contacts Gold Plated Copper Tin (CuSn), stamped from stock.
- Coupling Method..... Threaded nut: Chrome plated brass.
- Cord Construction ... PVC non-wicking, non-hygroscopic, 250VAC / 300VDC. Cable end is stripped.
- Conductors..... Extra high flex stranding with PVC insulation
- Temperature..... -13°F to 158°F (-25°C to 70°C)
- Protection NEMA 1, 3, 4, 6P and IEC 1P67
- Cable Length..... 6.56 ft (2m) or 16.4 ft (5m)

Straight Connector

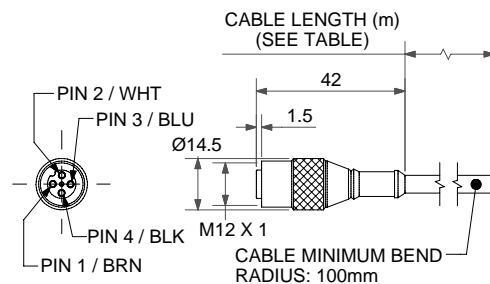

Right Angle Connector

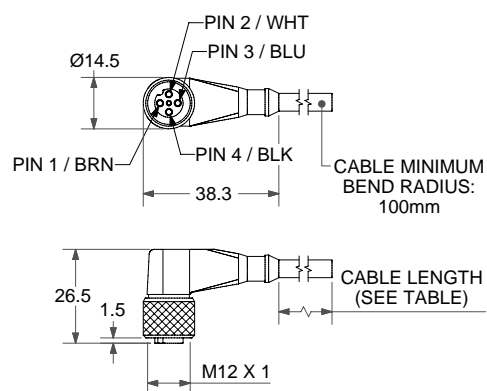

EPS-A Threaded Style End-Of-Stroke Inductive Proximity Sensor

Non-contacting, end-of-stroke position sensor

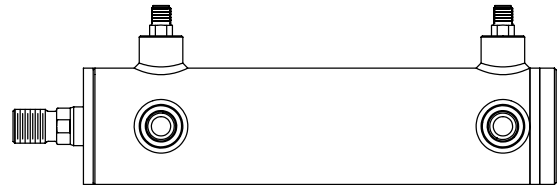
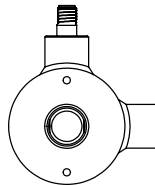
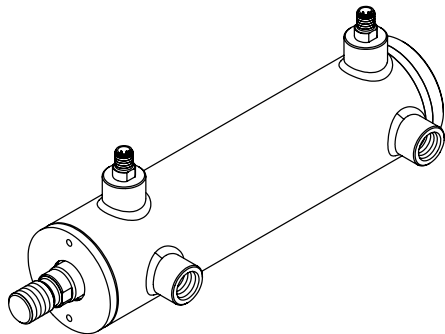

Note: Cylinders that include EPS-A Switches may be longer than standard cylinders. Consult Switch dimension tables for exact lengths.

- Shouldered one-piece stainless steel body for positive installation and easy replacement
- PNP (sourcing) output
- Normally Open function
- 10-30 VDC
- Minor voltage drop and leakage current
- CE, C-UL-US Approved
- IP68 rating
- 4-pin 12mm connector (standard)
- Cable and short cable/connector options

CLS-A Threaded Style End-Of-Stroke Limit Switches

Non-contacting, magnetically-actuating

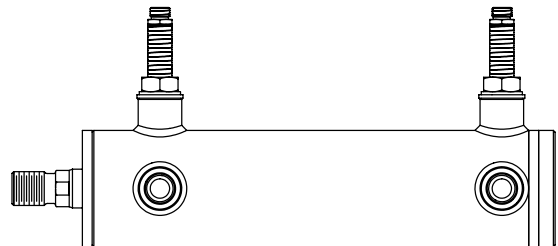
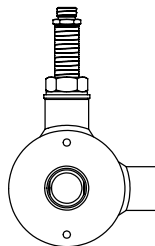
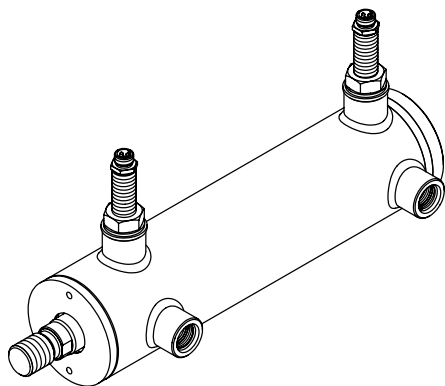

As shown in the illustrations below, these switches are magnetically operated. Dual magnets provide a dependable “snap action” for positive position sensing.

In the “Unoperated” position, the magnet assembly is attracted in the opposite direction of the arrow, causing a finely ground stainless steel connecting rod to hold the contacts open.

In the “Operated” position a ferrous part (piston or piston spacer) enters the sensing area and attracts the magnet assembly which causes the rod to draw the contacts together.

Threaded switches can be height-adjusted for small changes to end-of-stroke position sensing.

Note: Cylinders that include CLS-A Switches may be longer than standard cylinders. Consult Switch Dimension tables for exact lengths.

Operating Principle

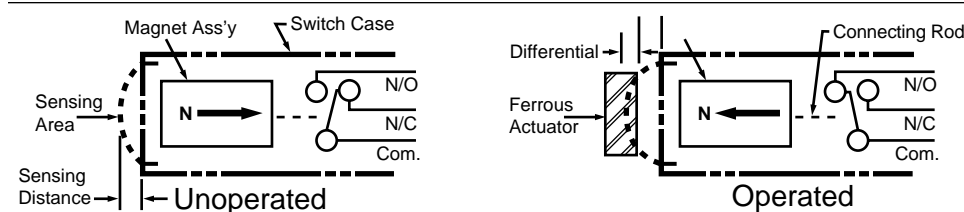

Sensing gap: .030" to .060"
Trip point: Factory set with piston bottomed out.
Release point: Approx. 0.250" of piston travel.
Minimum net stroke is 0.500" for 1.50" and 2.00" bores and 0.750" for larger bores.

See the specification table on the next page for additional details.

EPS-A Sensor /CLS-A Switch Specifications Common Modifications

EPS-A Sensor & CLS-A Limit Switch Specifications

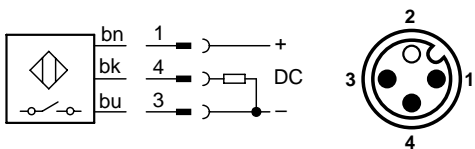
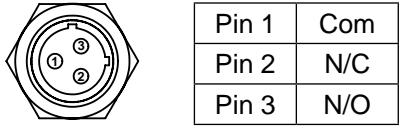
Switch Type:	Inductive Proximity	Non-contacting, magnetically actuating						
Style:	EPS-A	CLS-A						
Code Designator:	C	G						
Description:	“General Purpose, 3 wire, DC Sensor”	For applications where the customer needs NO or NC contacts, zero leakage, zero voltage drop, higher or lower load current than EPS style. Threaded style permits small adjustability of make/break location.						
Supply Voltage:	10 to 30 VDC	24 to 240 VAC/DC						
Load Current, max.:	200 mA	4 AMPS @ 120 VAC 3 AMPS @ 24 VDC						
Leakage Current:	10 µA	None						
Voltage Drop:	≤ 2.0 V	None						
Operating Temperature:	-13°F to +194°F	-40°F to +221°F						
Part Number:	0961640M12	0961710000 - 1.50" Bore 0961680000 - 2.00" - 8.00" Bores						
Connection:	M12 4-pin connector	3-pin micro connector						
Enclosure Rating:	Enclosure – IP68	Enclosure – IP68						
LED Indication:	No	No						
Short Circuit Protection:	Yes	No						
RFI/Weld Field Immune:	No	Yes						
Output:	PNP	SPDT (Single Pole Double Throw), Normally Open/Normally Closed, Form C						
Approvals/Marks:	CE	UL Listed General Purpose						
Make/Break Location:	0.25" from end of stroke typical. Tolerance is +0 / -0.13"	0.25" from end of stroke typical. Tolerance is +0 / -0.13"						
Wiring Instructions:		 <table border="1" data-bbox="1214 1438 1421 1564"> <tr> <td>Pin 1</td> <td>Com</td> </tr> <tr> <td>Pin 2</td> <td>N/C</td> </tr> <tr> <td>Pin 3</td> <td>N/O</td> </tr> </table>	Pin 1	Com	Pin 2	N/C	Pin 3	N/O
Pin 1	Com							
Pin 2	N/C							
Pin 3	N/O							
Options: (Consult factory)	5m cable	½" conduit hub, cable, flying lead and other connector types High temperature version (to +400°F) ATEX, CSA, intrinsically-safe, explosion-proof, non-incendive, DPDT and Subsea versions						

EPS-A & CLS-A limit switches may be ordered as follows:

- 1) Complete the basic cylinder model number.
- 2) Place an "S" in the model number for Special Modification.
- 3) Mounting styles DD, J and H should be used with caution because of possible mounting interferences.
- 4) Special modifications to cylinders other than switches must be described in the item notes.

- 5) Limit Switch Code – Specify letter prefix "C" for EPS-A or "G" for CLS-A, then fill in the four blanks specifying port location, switch location and actuation point for both head and cap. If only one switch is used, place "XXXX" in the unused blanks.

Example = G13GG-XXXX denotes a switch on the head end only.

Example = XXXX-G42GG denotes a switch on the cap end only.

Limit Switch Code

Head End

G	1	3	GG
Specify: "C" = EPS-A "G" = CLS-A "T" = Prepared for CLS-A Threaded Switch "X" = Special installed switch (Specify)	Port Location See Figure 1.	Switch Location See Figure 1.	Actuation Point GG = End of Stroke.

Cap End

4	2	GG
Port Location See Figure 1.	Switch Location See Figure 1.	Actuation Point GG = End of Stroke.

Note: All specified switch and port locations are as seen from rod end of cylinder.

Figure 1

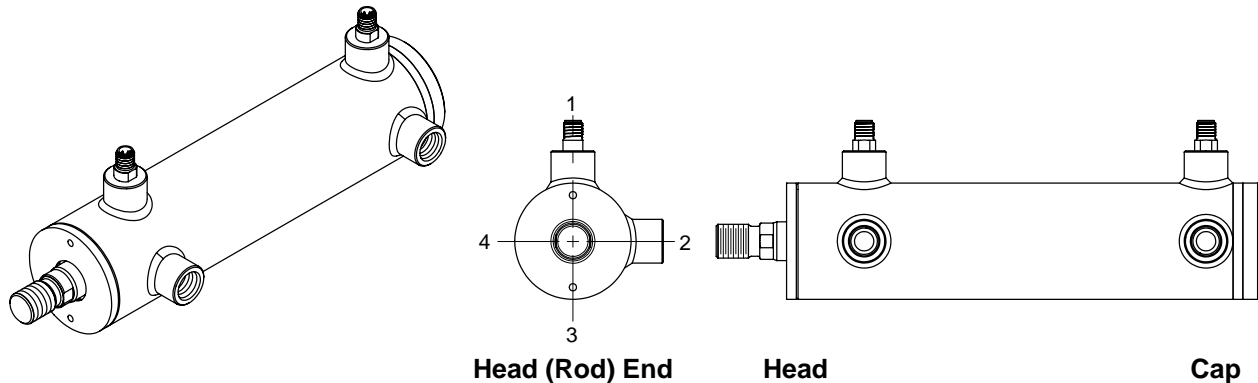

Dimensions – Cylinders with Limit Switches Common Modifications

Series RDH cylinders with Limit Switches require additional length for the piston collar(s) required to activate the switch. The table below and those on following pages show dimensions that are changed when switches are

specified. Note that dimension changes are specific to whether switches are specified on both ends, switch on cap end only or switch on head end only.

Switch on Both Ends

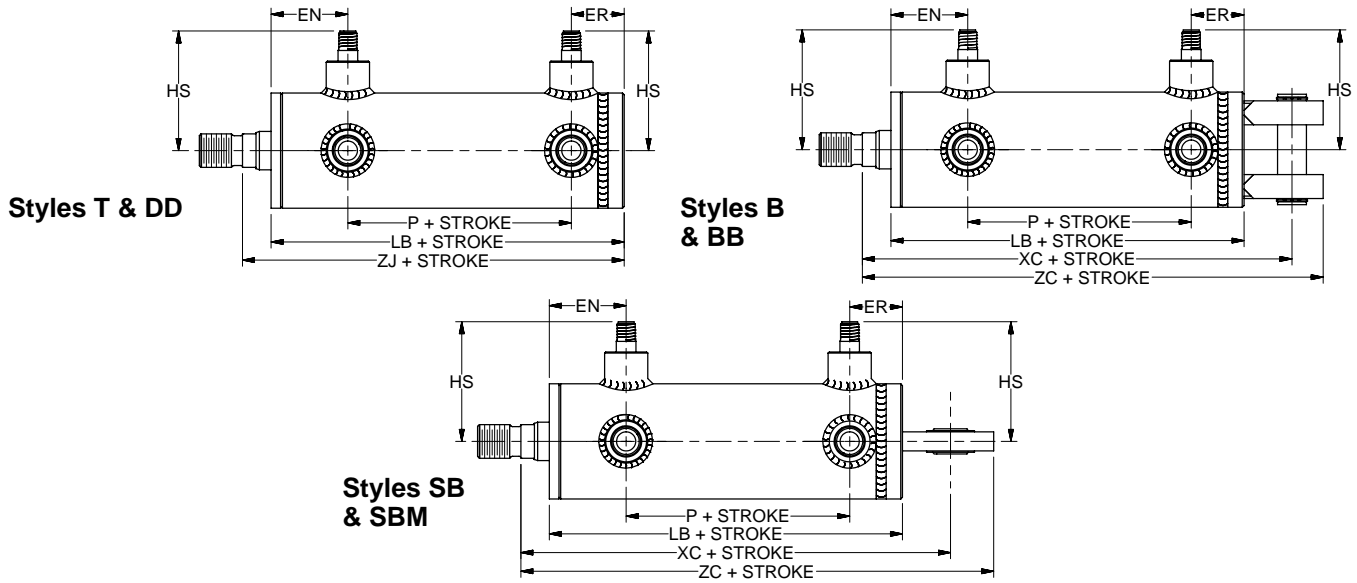

Bore Ø	Rod No.	MM Rod Ø	All Mountings				All Mountings Except Styles J/JP				Styles T & DD		Styles B & BB		Style SB		Style SBM	
			ER	HS		EN		Add Stroke		Add Stroke	Add Stroke	Add Stroke	Add Stroke	Add Stroke	Add Stroke			
				CLS-A	EPS-A	CLS-A	EPS-A	LB	P							ZJ	XC	ZC
1.50	1 (std)	0.625	0.83	4.49	2.66	1.63	1.63	4.19	1.82	4.75	5.50	6.00	5.50	6.25	5.73	6.87		
	2	1.000	0.83	4.49	2.66	2.01	2.01	4.56	1.82	5.25	6.00	6.50	6.00	6.75	6.23	7.38		
2.00	1 (std)	1.000	1.12	4.25	2.91	2.31	2.20	5.69	2.81	6.38	7.63	8.38	7.63	8.63	7.60	8.89		
	2	1.375	1.12	4.25	2.91	2.31	2.20	5.69	2.81	6.50	7.75	8.50	7.75	8.75	7.72	9.02		
2.50	1 (std)	1.000	1.31	4.47	3.13	2.56	2.45	6.13	2.75	6.81	8.06	8.81	8.06	9.06	8.31	9.88		
	2	1.750	1.31	4.47	3.13	2.56	2.45	6.13	2.75	7.06	8.31	9.06	8.31	9.31	8.56	10.13		
	3	1.375	1.31	4.47	3.13	2.56	2.45	6.13	2.75	6.94	8.19	8.94	8.19	9.19	8.43	10.01		
3.25	1 (std)	1.375	1.68	4.84	3.51	2.81	2.70	6.88	2.94	7.69	9.19	10.19	9.19	10.44	9.58	11.55		
	2	2.000	1.68	4.84	3.51	2.81	2.70	6.88	2.94	7.88	9.38	10.38	9.38	10.63	9.76	11.73		
	3	1.750	1.68	4.84	3.51	2.81	2.70	6.88	2.94	7.81	9.31	10.31	9.31	10.56	9.70	11.67		
4.00	1 (std)	1.750	1.44	5.15	3.82	3.06	2.95	7.25	3.25	8.19	10.31	11.69	10.31	12.19	10.47	12.91		
	2	2.500	1.44	5.15	3.82	3.06	2.95	7.25	3.25	8.31	10.44	11.81	10.44	12.31	10.59	13.03		
	3	2.000	1.44	5.15	3.82	3.06	2.95	7.25	3.25	8.25	10.37	11.75	10.37	12.25	10.53	12.97		
5.00	1 (std)	2.000	1.79	5.59	4.26	3.31	3.20	7.87	3.31	8.87	11.12	12.87	11.12	13.62	11.70	14.85		
	2	3.500	1.79	5.59	4.26	3.31	3.20	7.87	3.31	8.93	11.18	12.93	11.18	13.68	11.76	14.91		
	3	2.500	1.79	5.59	4.26	3.31	3.20	7.87	3.31	8.93	11.18	12.93	11.18	13.68	11.76	14.91		
	4	3.000	1.79	5.59	4.26	3.31	3.20	7.87	3.31	8.93	11.18	12.93	11.18	13.68	11.76	14.91		
6.00	1 (std)	2.500	2.36	6.09	4.76	3.19	3.14	8.37	3.00	9.43	11.93	13.93	11.93	14.43	13.05	16.99		
	2	4.000	2.36	6.09	4.76	3.19	3.14	8.37	3.00	9.43	11.93	13.93	11.93	14.43	13.05	16.99		
	3	3.000	2.36	6.09	4.76	3.19	3.14	8.37	3.00	9.43	11.93	13.93	11.93	14.43	13.05	16.99		
	4	3.500	2.36	6.09	4.76	3.19	3.14	8.37	3.00	9.43	11.93	13.93	11.93	14.43	13.05	16.99		
7.00	1 (std)	3.000	2.67	6.59	5.26	3.20	3.08	9.00	3.25	10.06	13.06	15.56	N/A		14.63	18.57		
	2	5.000	2.67	6.59	5.26	3.20	3.08	9.00	3.25	10.19	13.19	15.69			14.75	18.69		
	3	3.500	2.67	6.59	5.26	3.20	3.08	9.00	3.25	10.06	13.06	15.56			14.63	18.57		
	4	4.000	2.67	6.59	5.26	3.20	3.08	9.00	3.25	10.06	13.06	15.56			14.63	18.57		
	5	4.500	2.67	6.59	5.26	3.20	3.08	9.00	3.25	10.19	13.19	15.69			14.75	18.69		
8.00	1 (std)	3.500	2.96	7.09	5.76	3.41	3.29	9.50	3.25	10.56	13.81	16.56		15.12	19.85			
	2	5.500	2.96	7.09	5.76	3.41	3.29	9.50	3.25	10.68	13.93	16.68		15.25	19.97			
	3	4.000	2.96	7.09	5.76	3.41	3.29	9.50	3.25	10.56	13.81	16.56		15.12	19.85			
	4	4.500	2.96	7.09	5.76	3.41	3.29	9.50	3.25	10.68	13.93	16.68		15.25	19.97			
	5	5.000	2.96	7.09	5.76	3.41	3.29	9.50	3.25	10.68	13.93	16.68		15.25	19.97			

Dimensions – Cylinders with Limit Switches Common Modifications

Switch on Both Ends

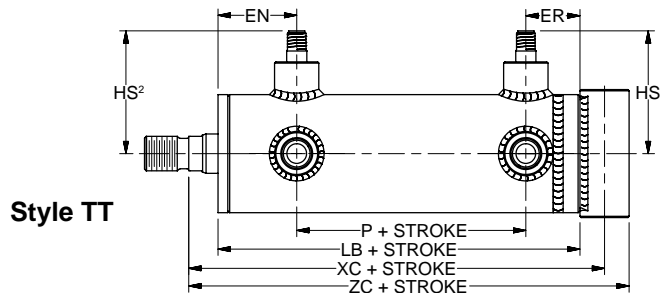
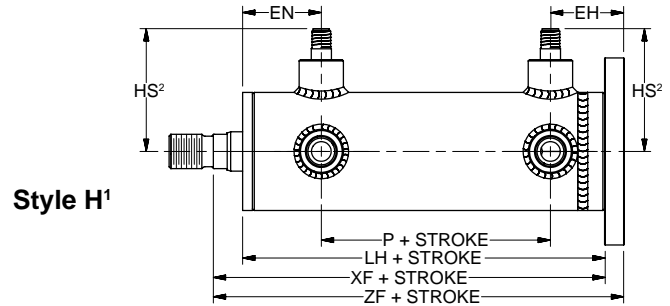
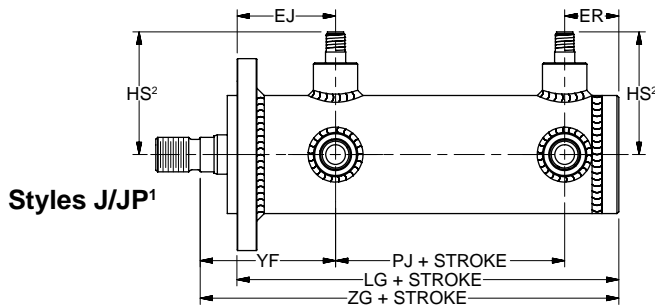

Bore Ø	Rod No.	MM Rod Ø	All Mountings Except Styles J/JP			Styles J/JP							Style H			Style TT				
			EN		Add Stroke	EJ		ER	YF	Add Stroke			EH	Add Stroke			ER	Add Stroke		
			CLS-A	EPS-A		CLS-A	EPS-A			LG	PJ	ZG		LH	XF	ZF		LB	XC	ZC
			P	P	P	P	P	P	P	P	P	P	P	P	P	P	P	P	P	
1.50	1 (std)	0.625	1.63	1.63	1.82	2.01	2.01	0.83	2.75	4.56	1.82	5.37	1.08	4.06	4.62	5.00	0.83	4.19	5.37	6.00
	2	1.000	2.01	2.01	1.82	2.01	2.01	0.83	3.25	4.56	1.82	5.88	1.08	4.44	5.13	5.50	0.83	4.56	5.88	6.50
2.00	1 (std)	1.000	2.31	2.20	2.81	2.44	2.33	1.12	3.26	5.81	2.81	6.75	1.43	5.56	6.25	6.69	1.12	5.69	7.00	7.63
	2	1.375	2.31	2.20	2.81	2.44	2.33	1.12	3.38	5.81	2.81	6.87	1.43	5.56	6.37	6.81	1.12	5.69	7.12	7.75
2.50	1 (std)	1.000	2.56	2.45	2.75	2.69	2.58	1.31	3.44	6.25	2.75	7.19	1.68	6.00	6.69	7.19	1.31	6.13	7.56	8.31
	2	1.750	2.56	2.45	2.75	2.69	2.58	1.31	3.69	6.25	2.75	7.44	1.68	6.00	6.94	7.44	1.31	6.13	7.81	8.56
	3	1.375	2.56	2.45	2.75	2.69	2.58	1.31	3.56	6.25	2.75	7.31	1.68	6.00	6.81	7.31	1.31	6.13	7.69	8.44
3.25	1 (std)	1.375	2.81	2.70	2.94	2.94	2.83	1.68	3.81	7.00	2.94	8.06	2.18	6.75	7.56	8.19	1.68	6.88	8.62	9.56
	2	2.000	2.81	2.70	2.94	2.94	2.83	1.68	4.00	7.00	2.94	8.25	2.18	6.75	7.75	8.38	1.68	6.88	8.81	9.75
	3	1.750	2.81	2.70	2.94	2.94	2.83	1.68	3.94	7.00	2.94	8.19	2.18	6.75	7.69	8.31	1.68	6.88	8.75	9.69
4.00	1 (std)	1.750	3.06	2.95	3.25	3.06	2.95	1.44	4.15	7.25	3.25	8.44	2.07	7.12	8.06	8.81	1.44	7.25	9.19	10.19
	2	2.500	3.06	2.95	3.25	3.06	2.95	1.44	4.27	7.25	3.25	8.56	2.07	7.12	8.19	8.94	1.44	7.25	9.31	10.31
	3	2.000	3.06	2.95	3.25	3.06	2.95	1.44	4.21	7.25	3.25	8.50	2.07	7.12	8.12	8.87	1.44	7.25	9.25	10.25
5.00	1 (std)	2.000	3.31	3.20	3.31	3.25	3.14	1.79	4.45	7.80	3.31	9.12	2.54	7.74	8.74	9.62	1.79	7.87	10.24	11.62
	2	3.500	3.31	3.20	3.31	3.25	3.14	1.79	4.51	7.80	3.31	9.18	2.54	7.74	8.80	9.68	1.79	7.87	10.30	11.68
	3	2.500	3.31	3.20	3.31	3.25	3.14	1.79	4.51	7.80	3.31	9.18	2.54	7.74	8.80	9.68	1.79	7.87	10.30	11.68
	4	3.000	3.31	3.20	3.31	3.25	3.14	1.79	4.51	7.80	3.31	9.18	2.54	7.74	8.80	9.68	1.79	7.87	10.30	11.68
6.00	1 (std)	2.500	3.19	3.14	3.00	3.56	3.51	2.36	4.99	8.75	3.00	10.18	3.24	8.25	9.31	10.31	2.36	8.37	10.93	12.43
	2	4.000	3.19	3.14	3.00	3.56	3.51	2.36	4.99	8.75	3.00	10.18	3.24	8.25	9.31	10.31	2.36	8.37	10.93	12.43
	3	3.000	3.19	3.14	3.00	3.56	3.51	2.36	4.99	8.75	3.00	10.18	3.24	8.25	9.31	10.31	2.36	8.37	10.93	12.43
	4	3.500	3.19	3.14	3.00	3.56	3.51	2.36	4.99	8.75	3.00	10.18	3.24	8.25	9.31	10.31	2.36	8.37	10.93	12.43
7.00	1 (std)	3.000	3.20	3.08	3.25	3.82	3.70	2.67	5.25	9.63	3.25	11.06	3.55	8.88	9.94	10.94	2.67	9.00	11.94	13.81
	2	5.000	3.20	3.08	3.25	3.82	3.70	2.67	5.38	9.63	3.25	11.19	3.55	8.88	10.06	11.06	2.67	9.00	12.06	13.94
	3	3.500	3.20	3.08	3.25	3.82	3.70	2.67	5.25	9.63	3.25	11.06	3.55	8.88	9.94	10.94	2.67	9.00	11.94	13.81
	4	4.000	3.20	3.08	3.25	3.82	3.70	2.67	5.25	9.63	3.25	11.06	3.55	8.88	9.94	10.94	2.67	9.00	11.94	13.81
	5	4.500	3.20	3.08	3.25	3.82	3.70	2.67	5.38	9.63	3.25	11.19	3.55	8.88	10.06	11.06	2.67	9.00	12.06	13.94
8.00	1 (std)	3.500	3.41	3.29	3.25	3.91	3.79	2.96	5.44	10.00	3.25	11.56	3.96	9.37	10.43	11.56	2.96	9.50	12.56	14.56
	2	5.500	3.41	3.29	3.25	3.91	3.79	2.96	5.56	10.00	3.25	11.68	3.96	9.37	10.56	11.68	2.96	9.50	12.68	14.68
	3	4.000	3.41	3.29	3.25	3.91	3.79	2.96	5.44	10.00	3.25	11.56	3.96	9.37	10.43	11.56	2.96	9.50	12.56	14.56
	4	4.500	3.41	3.29	3.25	3.91	3.79	2.96	5.56	10.00	3.25	11.68	3.96	9.37	10.56	11.68	2.96	9.50	12.68	14.68
	5	5.000	3.41	3.29	3.25	3.91	3.79	2.96	5.56	10.00	3.25	11.68	3.96	9.37	10.56	11.68	2.96	9.50	12.68	14.68

¹ See port and switch position note on mounting Styles J/JP & H pages.

² See previous page for HS dimensions.

Dimensions – Cylinders with Limit Switches Common Modifications

Switch on Head End

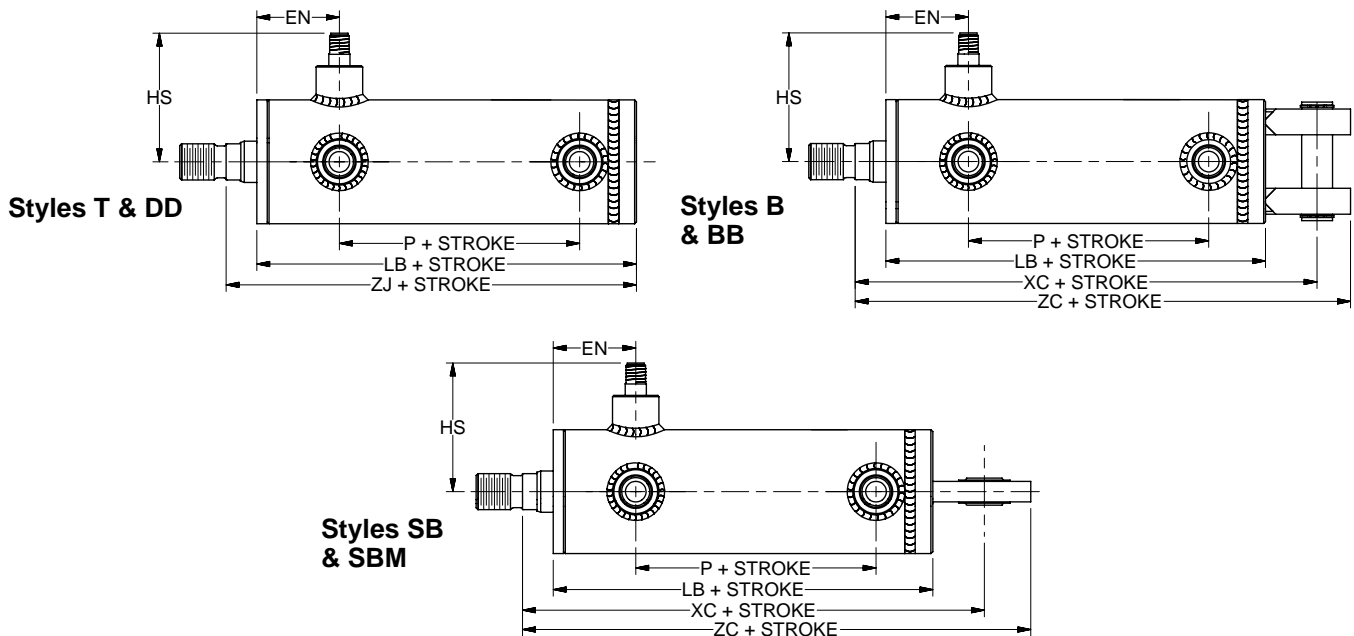

Bore Ø	Rod No.	MM Rod Ø	All Mountings		All Mountings Except Styles J/JP				Styles T & DD	Styles B & BB		Style SB		Style SBM	
			HS		EN		Add Stroke		Add Stroke	Add Stroke		Add Stroke		Add Stroke	
			CLS-A	EPS-A	CLS-A	EPS-A	LB	P	ZJ	XC	ZC	XC	ZC	XC	ZC
1.50	1 (std)	0.625	4.49	2.66	1.63	1.63	4.06	1.69	4.62	5.37	5.87	5.37	6.12	5.61	6.75
	2	1.000	4.49	2.66	2.01	2.01	4.44	1.69	5.13	5.88	6.38	5.88	6.63	6.11	7.25
2.00	1 (std)	1.000	4.25	2.91	2.31	2.20	5.56	2.68	6.25	7.50	8.25	7.50	8.50	7.47	8.77
	2	1.375	4.25	2.91	2.31	2.20	5.56	2.68	6.37	7.62	8.37	7.62	8.62	7.59	8.89
2.50	1 (std)	1.000	4.47	3.13	2.56	2.45	6.00	2.63	6.69	7.94	8.69	7.94	8.94	8.18	9.76
	2	1.750	4.47	3.13	2.56	2.45	6.00	2.63	6.94	8.19	8.94	8.19	9.19	8.43	10.01
	3	1.375	4.47	3.13	2.56	2.45	6.00	2.63	6.81	8.06	8.81	8.06	9.06	8.31	9.88
3.25	1 (std)	1.375	4.84	3.51	2.81	2.70	6.75	2.81	7.56	9.06	10.06	9.06	10.31	9.45	11.42
	2	2.000	4.84	3.51	2.81	2.70	6.75	2.81	7.75	9.25	10.25	9.25	10.50	9.64	11.61
	3	1.750	4.84	3.51	2.81	2.70	6.75	2.81	7.69	9.19	10.19	9.19	10.44	9.58	11.55
4.00	1 (std)	1.750	5.15	3.82	3.06	2.95	7.25	3.25	8.19	10.31	11.69	10.31	12.19	10.47	12.91
	2	2.500	5.15	3.82	3.06	2.95	7.25	3.25	8.31	10.44	11.81	10.44	12.31	10.59	13.03
	3	2.000	5.15	3.82	3.06	2.95	7.25	3.25	8.25	10.37	11.75	10.37	12.25	10.53	12.97
5.00	1 (std)	2.000	5.59	4.26	3.31	3.20	7.87	3.31	8.87	11.12	12.87	11.12	13.62	11.70	14.85
	2	3.500	5.59	4.26	3.31	3.20	7.87	3.31	8.93	11.18	12.93	11.18	13.68	11.76	14.91
	3	2.500	5.59	4.26	3.31	3.20	7.87	3.31	8.93	11.18	12.93	11.18	13.68	11.76	14.91
	4	3.000	5.59	4.26	3.31	3.20	7.87	3.31	8.93	11.18	12.93	11.18	13.68	11.76	14.91
6.00	1 (std)	2.500	6.09	4.76	3.19	3.14	8.37	3.00	9.43	11.93	13.93	11.93	14.43	13.05	16.99
	2	4.000	6.09	4.76	3.19	3.14	8.37	3.00	9.43	11.93	13.93	11.93	14.43	13.05	16.99
	3	3.000	6.09	4.76	3.19	3.14	8.37	3.00	9.43	11.93	13.93	11.93	14.43	13.05	16.99
	4	3.500	6.09	4.76	3.19	3.14	8.37	3.00	9.43	11.93	13.93	11.93	14.43	13.05	16.99
7.00	1 (std)	3.000	6.59	5.26	3.20	3.08	9.00	3.25	10.06	13.06	15.56	N/A			
	2	5.000	6.59	5.26	3.20	3.08	9.00	3.25	10.19	13.19	15.69				
	3	3.500	6.59	5.25	3.20	3.08	9.00	3.25	10.06	13.06	15.56				
	4	4.000	6.59	5.26	3.20	3.08	9.00	3.25	10.06	13.06	15.56				
	5	4.500	6.59	5.26	3.20	3.08	9.00	3.25	10.19	13.19	15.69				
8.00	1 (std)	3.500	7.09	5.76	3.41	3.29	9.50	3.25	10.56	13.81	16.56	N/A			
	2	5.500	7.09	5.76	3.41	3.29	9.50	3.25	10.68	13.93	16.68				
	3	4.000	7.09	5.76	3.41	3.29	9.50	3.25	10.56	13.81	16.56				
	4	4.500	7.09	5.76	3.41	3.29	9.50	3.25	10.68	13.93	16.68				
	5	5.000	7.09	5.76	3.41	3.29	9.50	3.25	10.68	13.93	16.68				

Dimensions – Cylinders with Limit Switches Common Modifications

Switch on Head End

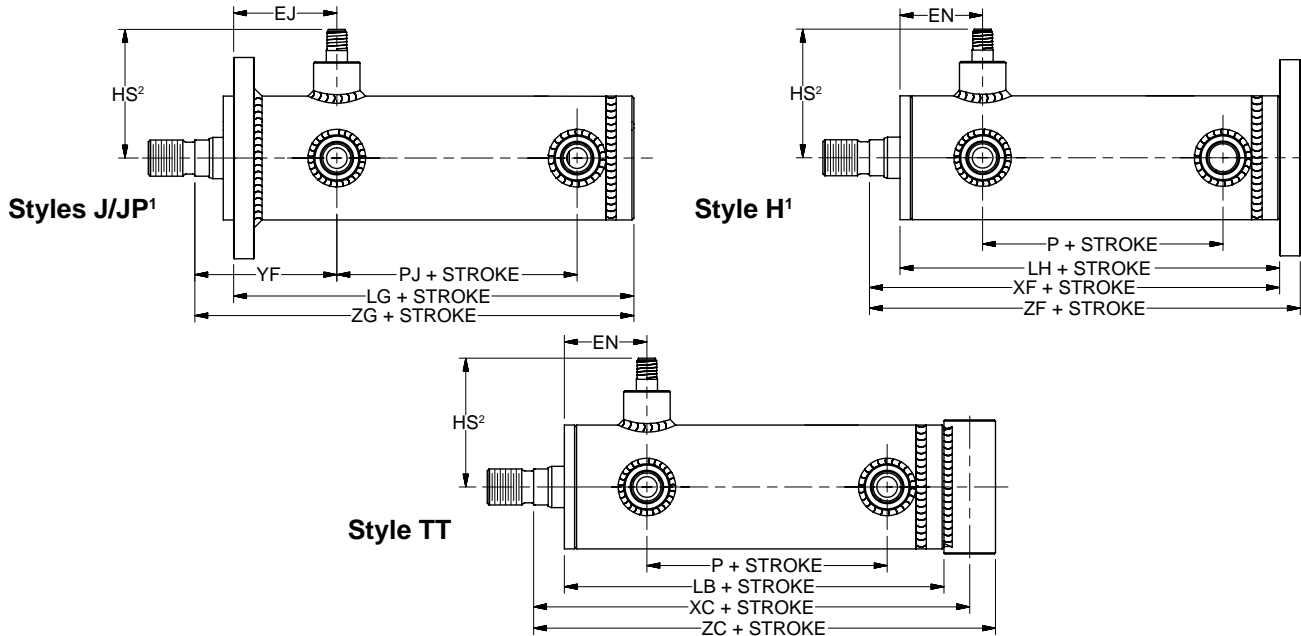

Bore Ø	Rod No.	MM Rod Ø	All Mountings Except Styles J/JP			Styles J/JP						Style H			Style TT		
			EN		Add Stroke	EJ		YF	Add Stroke			Add Stroke			Add Stroke		
			CLS-A	EPS-A	P	CLS-A	EPS-A		LG	PJ	ZG	LH	XF	ZF	LB	XC	ZC
1.50	1 (std)	0.625	1.63	1.63	1.69	2.01	2.01	2.75	4.44	1.69	5.25	3.94	4.50	4.87	4.06	5.25	5.87
	2	1.000	2.01	2.01	1.69	2.01	2.01	3.25	4.44	1.69	5.75	4.31	5.00	5.38	4.44	5.75	6.38
2.00	1 (std)	1.000	2.31	2.20	2.68	2.44	2.33	3.26	5.69	2.68	6.63	5.44	6.13	6.56	5.56	6.88	7.50
	2	1.375	2.31	2.20	2.68	2.44	2.33	3.38	5.69	2.68	6.75	5.44	6.25	6.69	5.56	7.00	7.62
2.50	1 (std)	1.000	2.56	2.45	2.63	2.69	2.58	3.44	6.13	2.63	7.06	5.88	6.56	7.06	6.00	7.44	8.19
	2	1.750	2.56	2.45	2.63	2.69	2.58	3.69	6.13	2.63	7.31	5.88	6.81	7.31	6.00	7.69	8.44
	3	1.375	2.56	2.45	2.63	2.69	2.58	3.56	6.13	2.63	7.19	5.88	6.69	7.19	6.00	7.56	8.31
3.25	1 (std)	1.375	2.81	2.70	2.81	2.94	2.83	3.81	6.88	2.81	7.94	6.63	7.44	8.06	6.75	8.50	9.44
	2	2.000	2.81	2.70	2.81	2.94	2.83	4.00	6.88	2.81	8.13	6.63	7.63	8.25	6.75	8.69	9.63
	3	1.750	2.81	2.70	2.81	2.94	2.83	3.94	6.88	2.81	8.06	6.63	7.56	8.19	6.75	8.63	9.56
4.00	1 (std)	1.750	3.06	2.95	3.25	3.06	2.95	4.15	7.25	3.25	8.44	7.12	8.06	8.81	7.25	9.19	10.19
	2	2.500	3.06	2.95	3.25	3.06	2.95	4.27	7.25	3.25	8.56	7.12	8.19	8.94	7.25	9.31	10.31
	3	2.000	3.06	2.95	3.25	3.06	2.95	4.21	7.25	3.25	8.50	7.12	8.12	8.87	7.25	9.25	10.25
5.00	1 (std)	2.000	3.31	3.20	3.31	3.25	3.14	4.45	7.80	3.31	9.12	7.74	8.74	9.62	7.87	10.24	11.62
	2	3.500	3.31	3.20	3.31	3.25	3.14	4.51	7.80	3.31	9.18	7.74	8.80	9.68	7.87	10.30	11.68
	3	2.500	3.31	3.20	3.31	3.25	3.14	4.51	7.80	3.31	9.18	7.74	8.80	9.68	7.87	10.30	11.68
	4	3.000	3.31	3.20	3.31	3.25	3.14	4.51	7.80	3.31	9.18	7.74	8.80	9.68	7.87	10.30	11.68
6.00	1 (std)	2.500	3.19	3.14	3.00	3.56	3.51	4.99	8.75	3.00	10.18	8.25	9.31	10.31	8.37	10.93	12.43
	2	4.000	3.19	3.14	3.00	3.56	3.51	4.99	8.75	3.00	10.18	8.25	9.31	10.31	8.37	10.93	12.43
	3	3.000	3.19	3.14	3.00	3.56	3.51	4.99	8.75	3.00	10.18	8.25	9.31	10.31	8.37	10.93	12.43
	4	3.500	3.19	3.14	3.00	3.56	3.51	4.99	8.75	3.00	10.18	8.25	9.31	10.31	8.37	10.93	12.43
7.00	1 (std)	3.000	3.20	3.08	3.25	3.82	3.70	5.25	9.63	3.25	11.06	8.88	9.94	10.94	9.00	11.94	13.81
	2	5.000	3.20	3.08	3.25	3.82	3.70	5.38	9.63	3.25	11.19	8.88	10.06	11.06	9.00	12.06	13.94
	3	3.500	3.20	3.08	3.25	3.82	3.70	5.25	9.63	3.25	11.06	8.88	9.94	10.94	9.00	11.94	13.81
	4	4.000	3.20	3.08	3.25	3.82	3.70	5.25	9.63	3.25	11.06	8.88	9.94	10.94	9.00	11.94	13.81
	5	4.500	3.20	3.08	3.25	3.82	3.70	5.38	9.63	3.25	11.19	8.88	10.06	11.06	9.00	12.06	13.94
8.00	1 (std)	3.500	3.41	3.29	3.25	3.91	3.79	5.44	10.00	3.25	11.56	9.37	10.43	11.56	9.50	12.56	14.56
	2	5.500	3.41	3.29	3.25	3.91	3.79	5.56	10.00	3.25	11.68	9.37	10.56	11.68	9.50	12.68	14.68
	3	4.000	3.41	3.29	3.25	3.91	3.79	5.44	10.00	3.25	11.56	9.37	10.43	11.56	9.50	12.56	14.56
	4	4.500	3.41	3.29	3.25	3.91	3.79	5.56	10.00	3.25	11.68	9.37	10.56	11.68	9.50	12.68	14.68
	5	5.000	3.41	3.29	3.25	3.91	3.79	5.56	10.00	3.25	11.68	9.37	10.56	11.68	9.50	12.68	14.68

¹ See port and switch position note on mounting Styles J/JP & H pages.

² See previous page for HS dimensions.

Dimensions – Cylinders with Limit Switches Common Modifications

Switch on Cap End

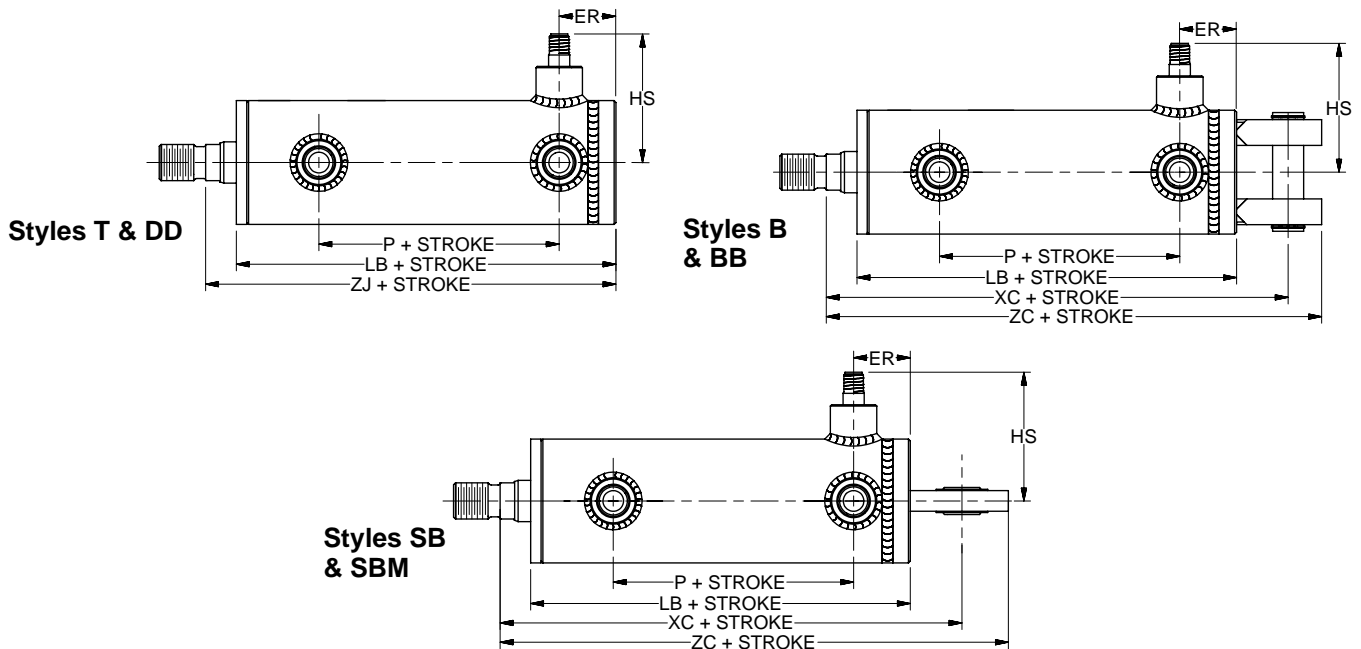

Bore Ø	Rod No.	MM Rod Ø	All Mountings Except Styles J/JP or H					Styles T & DD	Styles B & BB		Style SB		Style SBM	
			ER	HS		Add Stroke		Add Stroke	Add Stroke		Add Stroke		Add Stroke	
				CLS-A	EPS-A	LB	P	ZJ	XC	ZC	XC	ZC	XC	ZC
1.50	1 (std)	0.625	0.83	4.49	2.66	3.69	1.32	4.25	5.00	5.50	5.00	5.75	5.23	6.37
	2	1.000	0.83	4.49	2.66	4.06	1.32	4.75	5.50	6.00	5.50	6.25	5.73	6.88
2.00	1 (std)	1.000	1.12	4.25	2.91	4.94	2.06	5.63	6.88	7.63	6.88	7.88	6.85	8.14
	2	1.375	1.12	4.25	2.91	4.94	2.06	5.75	7.00	7.75	7.00	8.00	6.97	8.27
2.50	1 (std)	1.000	1.31	4.47	3.13	5.38	2.00	6.06	7.31	8.06	7.31	8.31	7.56	9.13
	2	1.750	1.31	4.47	3.13	5.38	2.00	6.31	7.56	8.31	7.56	8.56	7.81	9.38
	3	1.375	1.31	4.47	3.13	5.38	2.00	6.19	7.44	8.19	7.44	8.44	7.68	9.26
3.25	1 (std)	1.375	1.68	4.84	3.51	6.13	2.19	6.94	8.44	9.44	8.44	9.69	8.83	10.80
	2	2.000	1.68	4.84	3.51	6.13	2.19	7.13	8.63	9.63	8.63	9.88	9.01	10.98
	3	1.750	1.68	4.84	3.51	6.13	2.19	7.06	8.56	9.56	8.56	9.81	8.95	10.92
4.00	1 (std)	1.750	1.44	5.15	3.82	6.50	2.50	7.44	9.56	10.94	9.56	11.44	9.72	12.16
	2	2.500	1.44	5.15	3.82	6.50	2.50	7.56	9.69	11.06	9.69	11.56	9.84	12.28
	3	2.000	1.44	5.15	3.82	6.50	2.50	7.50	9.62	11.00	9.62	11.50	9.78	12.22
5.00	1 (std)	2.000	1.79	5.59	4.26	7.12	2.56	8.12	10.37	12.12	10.37	12.87	10.95	14.10
	2	3.500	1.79	5.59	4.26	7.12	2.56	8.18	10.43	12.18	10.43	12.93	11.01	14.16
	3	2.500	1.79	5.59	4.26	7.12	2.56	8.18	10.43	12.18	10.43	12.93	11.01	14.16
	4	3.000	1.79	5.59	4.26	7.12	2.56	8.18	10.43	12.18	10.43	12.93	11.01	14.16
6.00	1 (std)	2.500	2.36	6.09	4.76	8.37	3.00	9.43	11.93	13.93	11.93	14.43	13.05	16.99
	2	4.000	2.36	6.09	4.76	8.37	3.00	9.43	11.93	13.93	11.93	14.43	13.05	16.99
	3	3.000	2.36	6.09	4.76	8.37	3.00	9.43	11.93	13.93	11.93	14.43	13.05	16.99
	4	3.500	2.36	6.09	4.76	8.37	3.00	9.43	11.93	13.93	11.93	14.43	13.05	16.99
7.00	1 (std)	3.000	2.67	6.59	5.26	9.00	3.25	10.06	13.06	15.56	N/A			
	2	5.000	2.67	6.59	5.26	9.00	3.25	10.19	13.19	15.69				
	3	3.500	2.67	6.59	5.26	9.00	3.25	10.06	13.06	15.56				
	4	4.000	2.67	6.59	5.26	9.00	3.25	10.06	13.06	15.56				
	5	4.500	2.67	6.59	5.26	9.00	3.25	10.19	13.19	15.69				
8.00	1 (std)	3.500	2.96	7.09	5.76	9.50	3.25	10.56	13.81	16.56				
	2	5.500	2.96	7.09	5.76	9.50	3.25	10.68	13.93	16.68				
	3	4.000	2.96	7.09	5.76	9.50	3.25	10.56	13.81	16.56				
	4	4.500	2.96	7.09	5.76	9.50	3.25	10.68	13.93	16.68				
	5	5.000	2.96	7.09	5.76	9.50	3.25	10.58	13.93	16.68				

Dimensions – Cylinders with Limit Switches Common Modifications

Switch on Cap End

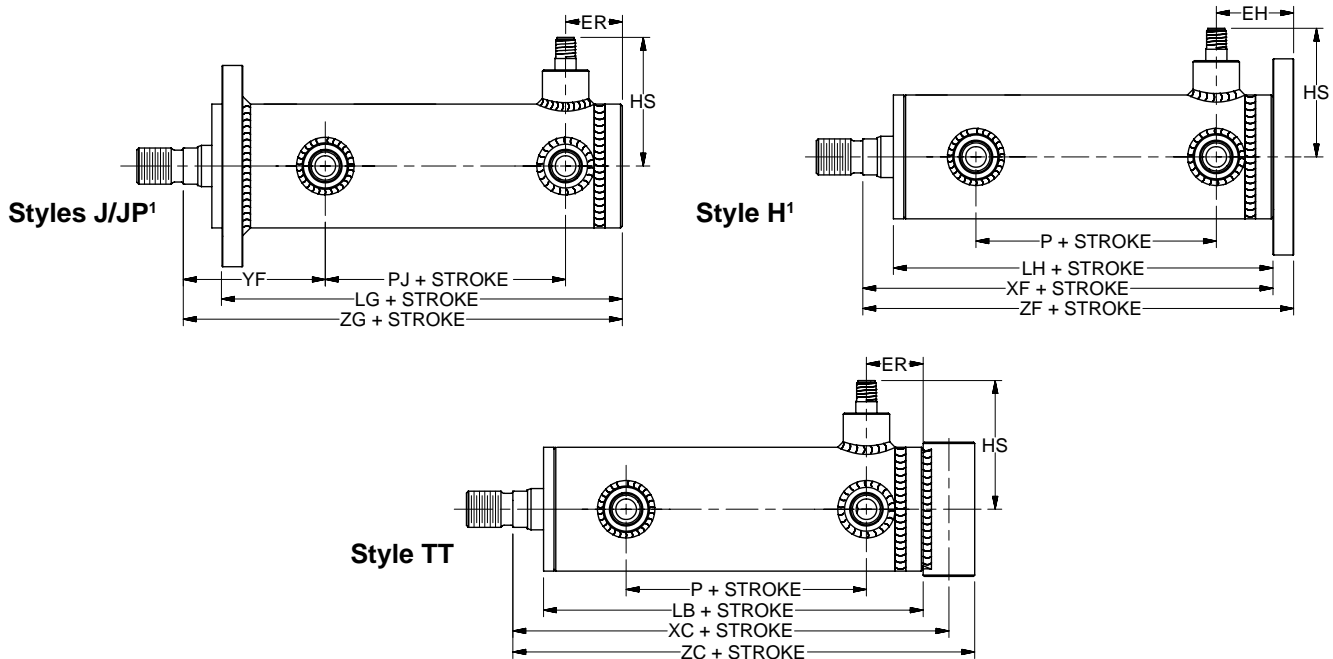

Bore Ø	Rod No.	MM Rod Ø	All Mountings		Styles J/JP					Style H				Style TT					
			HS		ER	YF	Add Stroke			EH	Add Stroke				ER	Add Stroke			
			CLS-A	EPS-A			LG	PJ	ZG		LH	P	XF	ZF		LB	P	XC	ZC
1.50	1 (std)	0.625	4.49	2.66	0.83	2.75	4.06	1.32	4.87	1.08	3.56	1.32	4.12	4.50	0.83	3.69	1.32	4.87	5.50
	2	1.000	4.49	2.66	0.83	3.25	4.06	1.32	5.38	1.08	3.94	1.32	4.63	5.00	0.83	4.06	1.32	5.38	6.00
2.00	1 (std)	1.000	4.25	2.91	1.12	3.26	5.44	2.06	6.38	1.43	4.81	2.06	5.50	5.94	1.12	4.94	2.06	6.25	6.88
	2	1.375	4.25	2.91	1.12	3.38	5.44	2.06	6.50	1.43	4.81	2.06	5.62	6.06	1.12	4.94	2.06	6.37	7.00
2.50	1 (std)	1.000	4.47	3.13	1.31	3.44	5.88	2.00	6.81	1.68	5.25	2.00	5.94	6.44	1.31	5.38	2.00	6.81	7.56
	2	1.750	4.47	3.13	1.31	3.69	5.88	2.00	7.06	1.68	5.25	2.00	6.19	6.69	1.31	5.38	2.00	7.06	7.81
	3	1.375	4.47	3.13	1.31	3.56	5.88	2.00	6.94	1.68	5.25	2.00	6.06	6.56	1.31	5.38	2.00	6.94	7.69
3.25	1 (std)	1.375	4.84	3.51	1.68	3.81	6.63	2.19	7.69	2.18	6.00	2.19	6.81	7.44	1.68	6.13	2.19	7.87	8.81
	2	2.000	4.84	3.51	1.68	4.00	6.63	2.19	7.88	2.18	6.00	2.19	7.00	7.63	1.68	6.13	2.19	8.06	9.00
	3	1.750	4.84	3.51	1.68	3.94	6.63	2.19	7.81	2.18	6.00	2.19	6.94	7.56	1.68	6.13	2.19	8.00	8.94
4.00	1 (std)	1.750	5.15	3.82	1.44	4.15	7.00	2.50	8.19	2.07	6.37	2.50	7.31	8.06	1.44	6.50	2.50	8.44	9.44
	2	2.500	5.15	3.82	1.44	4.27	7.00	2.50	8.31	2.07	6.37	2.50	7.44	8.19	1.44	6.50	2.50	8.56	9.56
	3	2.000	5.15	3.82	1.44	4.21	7.00	2.50	8.25	2.07	6.37	2.50	7.37	8.12	1.44	6.50	2.50	8.50	9.50
5.00	1 (std)	2.000	5.59	4.26	1.79	4.45	7.55	2.56	8.87	2.54	6.99	2.56	7.99	8.87	1.79	7.12	2.56	9.49	10.87
	2	3.500	5.59	4.26	1.79	4.51	7.55	2.56	8.93	2.54	6.99	2.56	8.05	8.93	1.79	7.12	2.56	9.55	10.93
	3	2.500	5.59	4.26	1.79	4.51	7.55	2.56	8.93	2.54	6.99	2.56	8.05	8.93	1.79	7.12	2.56	9.55	10.93
	4	3.000	5.59	4.26	1.79	4.51	7.55	2.56	8.93	2.54	6.99	2.56	8.05	8.93	1.79	7.12	2.56	9.55	10.93
6.00	1 (std)	2.500	6.09	4.76	2.36	4.99	8.75	3.00	10.18	3.24	8.25	3.00	9.31	10.31	2.36	8.37	3.00	10.93	12.43
	2	4.000	6.09	4.76	2.36	4.99	8.75	3.00	10.18	3.24	8.25	3.00	9.31	10.31	2.36	8.37	3.00	10.93	12.43
	3	3.000	6.09	4.76	2.36	4.99	8.75	3.00	10.18	3.24	8.25	3.00	9.31	10.31	2.36	8.37	3.00	10.93	12.43
	4	3.500	6.09	4.76	2.36	4.99	8.75	3.00	10.18	3.24	8.25	3.00	9.31	10.31	2.36	8.37	3.00	10.93	12.43
7.00	1 (std)	3.000	6.59	5.26	2.67	5.25	9.63	3.25	11.06	3.55	8.88	3.25	9.94	10.94	2.67	9.00	3.25	11.94	13.81
	2	5.000	6.59	5.26	2.67	5.38	9.63	3.25	11.19	3.55	8.88	3.25	10.06	11.06	2.67	9.00	3.25	12.06	13.94
	3	3.500	6.59	5.26	2.67	5.25	9.63	3.25	11.06	3.55	8.88	3.25	9.94	10.94	2.67	9.00	3.25	11.94	13.81
	4	4.000	6.59	5.26	2.67	5.25	9.63	3.25	11.06	3.55	8.88	3.25	9.94	10.94	2.67	9.00	3.25	11.94	13.81
	5	4.500	6.59	5.26	2.67	5.38	9.63	3.25	11.19	3.55	8.88	3.25	10.06	11.06	2.67	9.00	3.25	12.06	13.94
8.00	1 (std)	3.500	7.09	5.76	2.96	5.44	10.00	3.25	11.56	3.96	9.37	3.25	10.43	11.56	2.96	9.50	3.25	12.56	14.56
	2	5.500	7.09	5.76	2.96	5.56	10.00	3.25	11.68	3.96	9.37	3.25	10.56	11.68	2.96	9.50	3.25	12.68	14.68
	3	4.000	7.09	5.76	2.96	5.44	10.00	3.25	11.56	3.96	9.37	3.25	10.43	11.56	2.96	9.50	3.25	12.56	14.56
	4	4.500	7.09	5.76	2.96	5.56	10.00	3.25	11.68	3.96	9.37	3.25	10.56	11.68	2.96	9.50	3.25	12.68	14.68
	5	5.000	7.09	5.76	2.96	5.56	10.00	3.25	11.68	3.96	9.37	3.25	10.56	11.68	2.96	9.50	3.25	12.68	14.68

¹ See port and switch position note on mounting Styles J/JP & H pages.

Dimensions – Cylinders with Limit Switches Common Modifications

Switch on K-Type – Both Ends

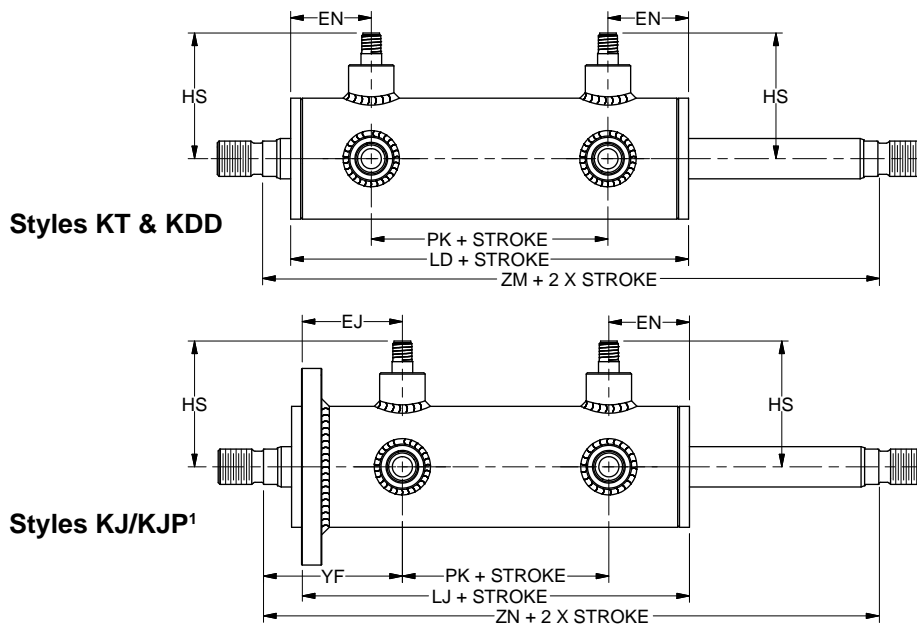

Bore Ø	Rod No.	MM Rod Ø	Styles KT, KDD & KJ / KJP					Style KT & KDD			Styles KJ / KJP				
			EN		HS		Add Stroke	Add Stroke	Add 2 X Stroke	EJ		YF	Add Stroke	Add 2 X Stroke	
			CLS-A	EPS-A	CLS-A	EPS-A	PK	LD	ZM	CLS-A	EPS-A		LJ	ZN	
1.50	1 (std)	0.625	1.63	1.63	4.49	2.66	1.91	5.03	6.10	2.01	2.01	2.75	5.40	6.73	
	2	1.000	2.01	2.01	4.49	2.66	1.91	5.78	7.10	2.01	2.01	3.25	5.78	7.73	
2.00	1 (std)	1.000	2.31	2.20	4.25	2.91	3.26	6.90	7.66	2.44	2.33	3.26	7.03	8.03	
	2	1.375	2.31	2.20	4.25	2.91	3.26	6.90	7.90	2.44	2.33	3.38	7.03	8.28	
2.50	1 (std)	1.000	2.56	2.45	4.47	3.13	3.40	7.40	8.16	2.69	2.58	3.44	7.53	8.53	
	2	1.750	2.56	2.45	4.47	3.13	3.40	7.40	8.66	2.69	2.58	3.69	7.53	9.03	
	3	1.375	2.56	2.45	4.47	3.13	3.40	7.40	8.40	2.69	2.58	3.56	7.53	8.78	
3.25	1 (std)	1.375	2.81	2.70	4.84	3.51	3.53	8.03	9.03	2.94	2.83	3.81	8.15	9.40	
	2	2.000	2.81	2.70	4.84	3.51	3.53	8.03	9.41	2.94	2.83	4.00	8.15	9.78	
	3	1.750	2.81	2.70	4.84	3.51	3.53	8.03	9.28	2.94	2.83	3.94	8.15	9.66	
4.00	1 (std)	1.750	3.06	2.95	5.15	3.82	3.86	8.78	9.91	3.06	2.95	4.15	8.78	10.16	
	2	2.500	3.06	2.95	5.15	3.82	3.86	8.78	10.15	3.06	2.95	4.27	8.78	10.40	
	3	2.000	3.06	2.95	5.15	3.82	3.86	8.78	10.03	3.06	2.95	4.21	8.78	10.28	
5.00	1 (std)	2.000	3.31	3.20	5.59	4.26	4.00	9.40	10.66	3.25	3.14	4.45	9.34	10.91	
	2	3.500	3.31	3.20	5.59	4.26	4.00	9.40	10.78	3.25	3.14	4.51	9.34	11.03	
	3	2.500	3.31	3.20	5.59	4.26	4.00	9.40	10.78	3.25	3.14	4.51	9.34	11.03	
	4	3.000	3.31	3.20	5.59	4.26	4.00	9.40	10.78	3.25	3.14	4.51	9.34	11.03	
6.00	1 (std)	2.500	3.19	3.14	6.09	4.76	2.92	9.28	11.28	3.56	3.51	4.99	9.65	12.03	
	2	4.000	3.19	3.14	6.09	4.76	2.92	9.28	11.28	3.56	3.51	4.99	9.65	12.03	
	3	3.000	3.19	3.14	6.09	4.76	2.92	9.28	11.28	3.56	3.51	4.99	9.65	12.03	
	4	3.500	3.19	3.14	6.09	4.76	2.92	9.28	11.28	3.56	3.51	4.99	9.65	12.03	
7.00	1 (std)	3.000	3.20	3.08	6.59	5.26	3.16	9.54	11.67	3.82	3.70	5.25	10.16	12.67	
	2	5.000	3.20	3.08	6.59	5.26	3.16	9.54	11.92	3.82	3.70	5.38	10.16	12.92	
	3	3.500	3.20	3.08	6.59	5.26	3.16	9.54	11.67	3.82	3.70	5.25	10.16	12.67	
	4	4.000	3.20	3.08	6.59	5.26	3.16	9.54	11.67	3.82	3.70	5.25	10.16	12.67	
	5	4.500	3.20	3.08	6.59	5.26	3.16	9.54	11.92	3.82	3.70	5.38	10.16	12.92	
8.00	1 (std)	3.500	3.41	3.29	7.09	5.76	3.21	9.96	12.09	3.91	3.79	5.44	10.46	13.09	
	2	5.500	3.41	3.29	7.09	5.76	3.21	9.96	12.34	3.91	3.79	5.56	10.46	13.34	
	3	4.000	3.41	3.29	7.09	5.76	3.21	9.96	12.09	3.91	3.79	5.44	10.46	13.09	
	4	4.500	3.41	3.29	7.09	5.76	3.21	9.96	12.34	3.91	3.79	5.56	10.46	13.34	
	5	5.000	3.41	3.29	7.09	5.76	3.21	9.96	12.34	3.91	3.79	5.56	10.46	13.34	

¹ See port and switch position note on mounting Styles J/JP dimension page.

Dimensions – Cylinders with Limit Switches Common Modifications

Switch on K-Type – End 1 Only

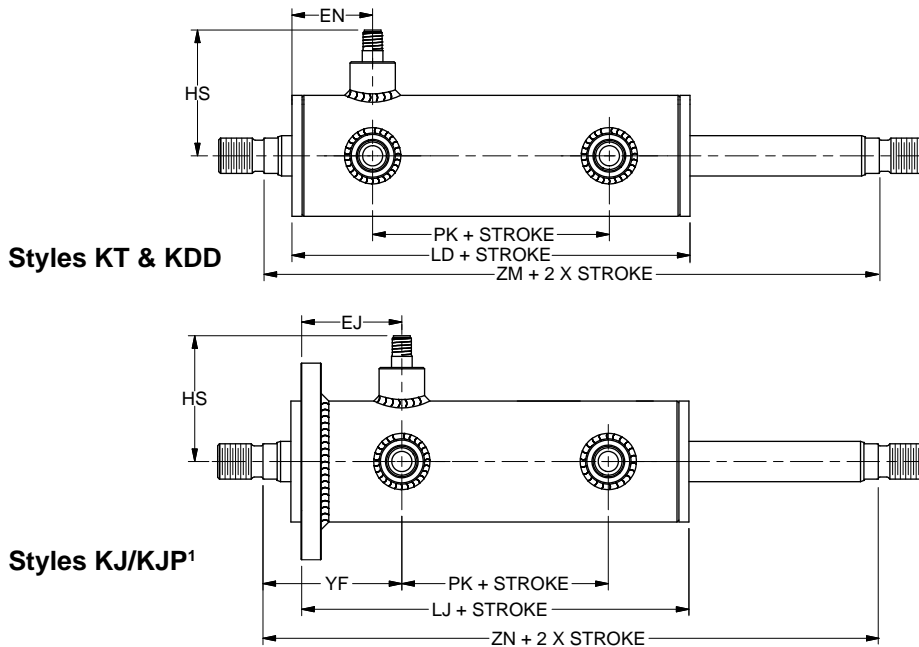

Bore Ø	Rod No.	MM Rod Ø	Styles KT, KDD & KJ / KJP			Styles KT & KDD				Styles KJ / KJP				
			HS		Add Stroke	EN		Add Stroke	Add 2 X Stroke	EJ		YF	Add Stroke	Add 2 X Stroke
			CLS-A	EPS-A	PK	CLS-A	EPS-A	LD	ZM	CLS-A	EPS-A	LJ	ZN	
1.50	1 (std)	0.625	4.49	2.66	1.72	1.63	1.63	4.84	5.98	2.01	2.01	2.75	5.21	6.60
	2	1.000	4.49	2.66	1.72	2.01	2.01	5.59	6.98	2.01	2.01	3.25	5.59	7.60
2.00	1 (std)	1.000	4.25	2.91	2.51	2.31	2.20	6.15	7.53	2.44	2.33	3.26	6.28	7.91
	2	1.375	4.25	2.91	2.51	2.31	2.20	6.15	7.78	2.44	2.33	3.38	6.28	8.15
2.50	1 (std)	1.000	4.47	3.13	2.65	2.56	2.45	6.65	8.03	2.69	2.58	3.44	6.78	8.41
	2	1.750	4.47	3.13	2.65	2.56	2.45	6.65	8.53	2.69	2.58	3.69	6.78	8.91
	3	1.375	4.47	3.13	2.65	2.56	2.45	6.65	8.28	2.69	2.58	3.56	6.78	8.65
3.25	1 (std)	1.375	4.84	3.51	2.78	2.81	2.70	7.28	8.90	2.94	2.83	3.81	7.40	9.28
	2	2.000	4.84	3.51	2.78	2.81	2.70	7.28	9.28	2.94	2.83	4.00	7.40	9.66
	3	1.750	4.84	3.51	2.78	2.81	2.70	7.28	9.16	2.94	2.83	3.94	7.40	9.53
4.00	1 (std)	1.750	5.15	3.82	3.11	3.06	2.95	8.03	9.91	3.06	2.95	4.15	8.03	10.16
	2	2.500	5.15	3.82	3.11	3.06	2.95	8.03	10.15	3.06	2.95	4.27	8.03	10.40
	3	2.000	5.15	3.82	3.11	3.06	2.95	8.03	10.03	3.06	2.95	4.21	8.03	10.28
5.00	1 (std)	2.000	5.59	4.26	3.25	3.31	3.20	8.65	10.66	3.25	3.14	4.45	8.59	10.91
	2	3.500	5.59	4.26	3.25	3.31	3.20	8.65	10.78	3.25	3.14	4.51	8.59	11.03
	3	2.500	5.59	4.26	3.25	3.31	3.20	8.65	10.78	3.25	3.14	4.51	8.59	11.03
	4	3.000	5.59	4.26	3.25	3.31	3.20	8.65	10.78	3.25	3.14	4.51	8.59	11.03
6.00	1 (std)	2.500	6.09	4.76	2.79	3.19	3.14	9.15	11.28	3.56	3.51	4.99	9.53	12.03
	2	4.000	6.09	4.76	2.79	3.19	3.14	9.15	11.28	3.56	3.51	4.99	9.53	12.03
	3	3.000	6.09	4.76	2.79	3.19	3.14	9.15	11.28	3.56	3.51	4.99	9.53	12.03
	4	3.500	6.09	4.76	2.79	3.19	3.14	9.15	11.28	3.56	3.51	4.99	9.53	12.03
7.00	1 (std)	3.000	6.59	5.26	3.16	3.20	3.08	9.54	11.67	3.82	3.70	5.25	10.16	12.67
	2	5.000	6.59	5.26	3.16	3.20	3.08	9.54	11.92	3.82	3.70	5.38	10.16	12.92
	3	3.500	6.59	5.26	3.16	3.20	3.08	9.54	11.67	3.82	3.70	5.25	10.16	12.67
	4	4.000	6.59	5.26	3.16	3.20	3.08	9.54	11.67	3.82	3.70	5.25	10.16	12.67
	5	4.500	6.59	5.26	3.16	3.20	3.08	9.54	11.92	3.82	3.70	5.38	10.16	12.92
8.00	1 (std)	3.500	7.09	5.76	3.21	3.41	3.29	9.96	12.09	3.91	3.79	5.44	10.46	13.09
	2	5.500	7.09	5.76	3.21	3.41	3.29	9.96	12.34	3.91	3.79	5.56	10.46	13.34
	3	4.000	7.09	5.76	3.21	3.41	3.29	9.96	12.09	3.91	3.79	5.44	10.46	13.09
	4	4.500	7.09	5.76	3.21	3.41	3.29	9.96	12.34	3.91	3.79	5.56	10.46	13.34
	5	5.000	7.09	5.76	3.21	3.41	3.29	9.96	12.34	3.91	3.79	5.56	10.46	13.34

¹ See port and switch position note on mounting Style J dimension page.



Dimensions – Cylinders with Limit Switches Common Modifications

Switch on K-Type – End 2 Only

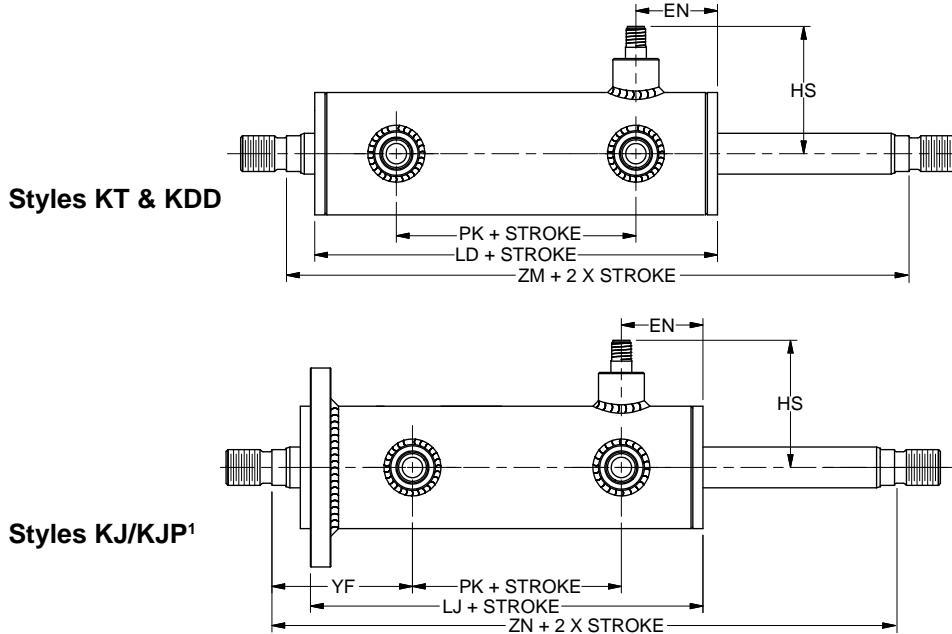

Rod No.	MM Rod Ø	Styles KT, KDD & KJ / KJP					Styles KT & KDD			Styles KJ / KJP		
		EN		HS		Add Stroke	Add Stroke	Add 2 X Stroke	YF	Add Stroke	Add 2 X Stroke	
		CLS-A	EPS-A	CLS-A	EPS-A	PK	LD	ZM		LJ	ZN	
1 (std)	0.625	1.63	1.63	4.49	2.66	1.41	4.53	5.60	2.75	4.90	6.23	
2	1.000	2.01	2.01	4.49	2.66	1.41	5.28	6.60	3.25	5.28	7.23	
1 (std)	1.000	2.31	2.20	4.25	2.91	2.51	6.15	6.91	3.26	6.65	7.66	
2	1.375	2.31	2.20	4.25	2.91	2.51	6.15	7.15	3.38	6.65	7.90	
1 (std)	1.000	2.56	2.45	4.47	3.13	2.65	6.65	7.41	3.44	7.15	8.16	
2	1.750	2.56	2.45	4.47	3.13	2.65	6.65	7.91	3.69	7.15	8.66	
3	1.375	2.56	2.45	4.47	3.13	2.65	6.65	7.65	3.56	7.15	8.40	
1 (std)	1.375	2.81	2.70	4.84	3.51	2.78	7.28	8.28	3.81	7.78	9.03	
2	2.000	2.81	2.70	4.84	3.51	2.78	7.28	8.66	4.00	7.78	9.41	
3	1.750	2.81	2.70	4.84	3.51	2.78	7.28	8.53	3.94	7.78	9.28	
1 (std)	1.750	3.06	2.95	5.15	3.82	3.11	8.03	9.16	4.15	8.53	9.91	
2	2.500	3.06	2.95	5.15	3.82	3.11	8.03	9.40	4.27	8.53	10.15	
3	2.000	3.06	2.95	5.15	3.82	3.11	8.03	9.28	4.21	8.53	10.03	
1 (std)	2.000	3.31	3.20	5.59	4.26	3.25	8.65	9.91	4.45	9.09	10.66	
2	3.500	3.31	3.20	5.59	4.26	3.25	8.65	10.03	4.51	9.09	10.78	
3	2.500	3.31	3.20	5.59	4.26	3.25	8.65	10.03	4.51	9.09	10.78	
4	3.000	3.31	3.20	5.59	4.26	3.25	8.65	10.03	4.51	9.09	10.78	
1 (std)	2.500	3.19	3.14	6.09	4.76	2.92	9.28	11.28	4.99	9.65	12.03	
2	4.000	3.19	3.14	6.09	4.76	2.92	9.28	11.28	4.99	9.65	12.03	
3	3.000	3.19	3.14	6.09	4.76	2.92	9.28	11.28	4.99	9.65	12.03	
4	3.500	3.19	3.14	6.09	4.76	2.92	9.28	11.28	4.99	9.65	12.03	
1 (std)	3.000	3.20	3.08	6.59	5.26	3.16	9.54	11.67	5.25	10.16	12.67	
2	5.000	3.20	3.08	6.59	5.26	3.16	9.54	11.92	5.38	10.16	12.92	
3	3.500	3.20	3.08	6.59	5.26	3.16	9.54	11.67	5.25	10.16	12.67	
4	4.000	3.20	3.08	6.59	5.26	3.16	9.54	11.67	5.25	10.16	12.67	
5	4.500	3.20	3.08	6.59	5.26	3.16	9.54	11.92	5.38	10.16	12.92	
1 (std)	3.500	3.41	3.29	7.09	5.76	3.21	9.96	12.09	5.44	10.46	13.09	
2	5.500	3.41	3.29	7.09	5.76	3.21	9.96	12.34	5.56	10.46	13.34	
3	4.000	3.41	3.29	7.09	5.76	3.21	9.96	12.09	5.44	10.46	13.09	
4	4.500	3.41	3.29	7.09	5.76	3.21	9.96	12.34	5.56	10.46	13.34	
5	5.000	3.41	3.29	7.09	5.76	3.21	9.96	12.34	5.56	10.46	13.34	

¹ See port and switch position note on mounting Style J dimension page.

Notes

C

Port Mounted Counterbalance Valves Add Versatility to Series RDH Cylinders

- Offer hose break protection
- Prevent loads from drifting
- Control overrunning loads
- Provide overcenter load control
- Protect against pressure due to thermal expansion

Counterbalance valves can be supplied for control of both extend and retract stroke or only in one stroke direction. The valve manifold can be installed on either the head end or cap end. Carbon steel hydraulic tubing connects the valve manifold to the opposite end port. A Lenz fitting in the manifold port is plumbed to a matched SAE size zinc plated Triple-Lok fitting in the cylinder port.

Many functional options are available to suit a wide variety of applications:

- 3 Valve Manifold sizes with 3 flow choices per size
- 3 standard pressure settings – 1,000, 2,000 and 3,000 psi
- 4 standard pressure adjustment ranges
- 2 pilot ratios – 3 to 1 or 4.5 to 1
- Class 1 (standard) or Class 5 seals (contact the factory for other seal classes)

Required information for selecting the correct Counterbalance Valve for your application:

1. Oil flow through the port in GPM
2. System operating pressure in psi
3. Pressure (psi) to hold the load
4. Valve manifold location – head or cap
5. Control of both extend and retract stroke or only in one stroke direction

Note – control of only one stroke direction affects the required manifold location:

- Manifold must be mounted at the cap end for retract stroke control and load holding
- Manifold must be mounted at the head end for extend stroke control and load holding

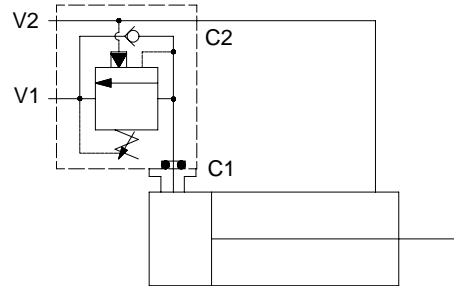

Single Counterbalance, Cap Mounted

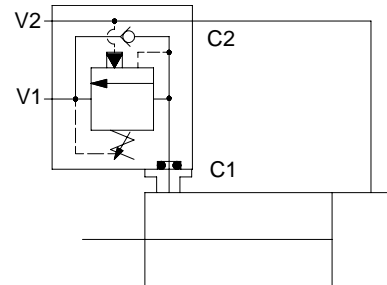

Single Counterbalance, Head Mounted

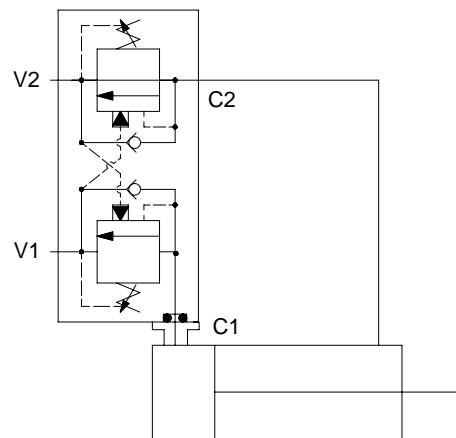

Double Counterbalance, Cap Mounted

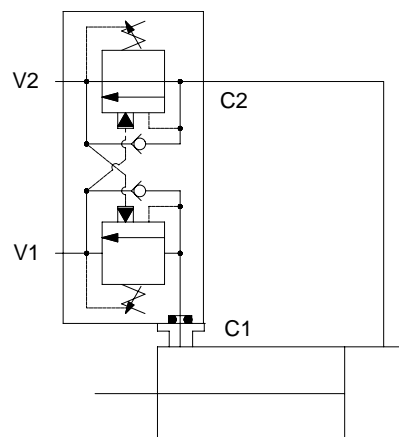

Double Counterbalance, Head Mounted

RDH Counterbalance Valve Manifold Assembly Ordering Code

Counterbalance Valves can be ordered on Series RDH cylinders as follows.

- 1) Complete the basic cylinder model number.
- 2) Place an 'S' in the model number to denote Special Modifications.
- 3) Specify the Counterbalance Valve Manifold option Ordering Code by making selections from the categories below.

	A	S	A	C	CA	H	N	A	-	3000	/	2500
Valve Manifold Size												
A – SAE 6 Port - 5 GPM ¹												
B – SAE 8 Port - 10 GPM ¹												
C – SAE 12 Port - 20 GPM ¹												
D – SAE 16 Port - 40 GPM ¹												
Single or Double Valve												
S – Single – Control in one direction												
D – Double – Control in both directions												
Valve Manifold Material												
A – Aluminum												
D – Ductile Iron												
Cap End or Head End Mounted												
C – Cap End Mounted												
H – Head End Mounted												
Counterbalance Valve Capacity & Pilot Ratio												
See Table A												
Pressure Range												
Valves with 3 to 1 Pilot Ratio												
H – 1000 to 4000 psi (3000 psi std. setting)												
I – 400 to 1500 psi (1000 psi std. setting)												
Valves with 4.5 to 1 Pilot Ratio												
J – 2000 to 5000 psi (3000 psi std. setting)												
K – 1000 to 2500 psi (2000 psi std. setting)												
Seals												
N – NBR - Nitrile												
V – FKM - Fluorocarbon												
Valve Adjustment												
A – Screw Adjust (Std)												
T – with Tamper Resist Cover												
Pressure Setting												
Single Valve Manifold – pressure setting of counterbalance valve (psi)												
or												
Double Valve Manifold – pressure setting of counterbalance valve on C1 port (psi)												
Pressure Setting – C2 Port (Double Valve Manifold Only)												
Double Valve Manifold - pressure setting of counterbalance valve on C2 port (psi)												

¹ Nominal flow for port size at 25 fps velocity.

Table A – Counterbalance Valve Capacity & Pilot Ratio

Counterbalance Valve Capacity	Valve Manifold Size A			Valve Manifold Size B			Valve Manifold Sizes C & D		
	Rated Max. Flow (GPM)	Pilot Ratio	Order Code	Rated Max. Flow (GPM)	Pilot Ratio	Order Code	Rated Max. Flow (GPM)	Pilot Ratio	Order Code
Standard	15	3:1	CA	30	3:1	EA	60	3:1	GA
Standard	15	4.5:1	CG	30	4.5:1	EG	60	4.5:1	GG
Semi-Restrictive	10	3:1	BC	20	3:1	DC	40	3:1	FC
Semi-Restrictive	10	4.5:1	BD	20	4.5:1	DD	40	4.5:1	FD
Restrictive	5	3:1	BA	8	3:1	DA	15	3:1	FA
Restrictive	5	4.5:1	BG	8	4.5:1	DG	15	4.5:1	FG



Counterbalance Valve Control of One Stroke Direction Only – Dimensions

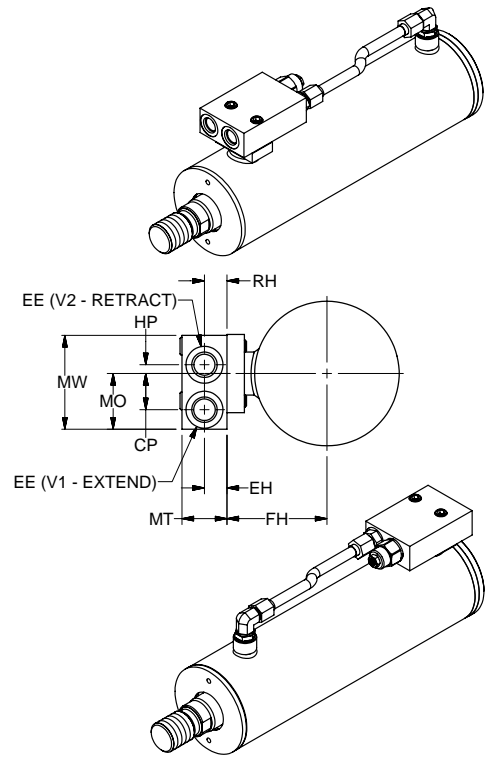
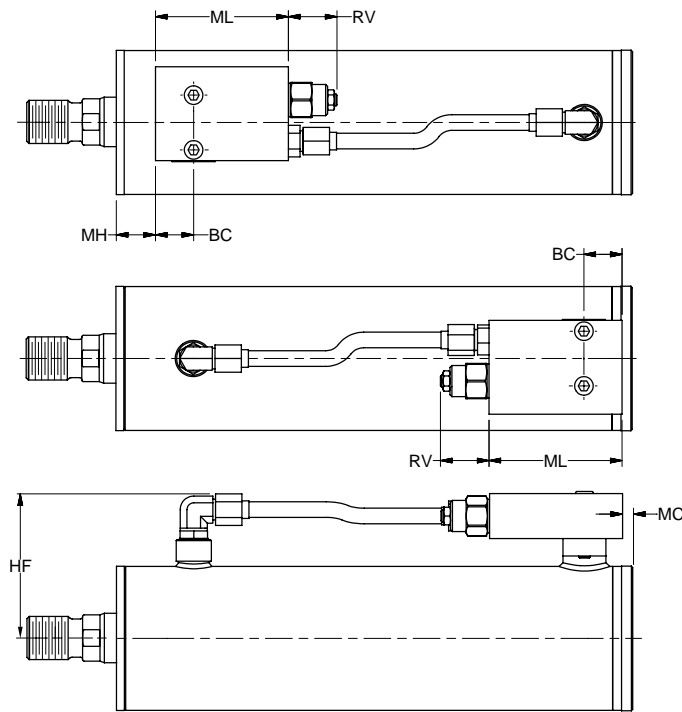

Bore Ø	Rod No.	Manifold Size	Min. Stroke	BC	CP	EE SAE	EH	FH	HF	HP	MC ¹	MH	ML	MO	MT	MW	RH	RV
1.50	1	A	5.50	1.00	0.96	6	0.59	1.79	3.00	0.22	-0.19	0.56	3.75	1.46	1.18	2.50	0.59	1.27
	2	A	5.50	1.00	0.96	6	0.59	1.79	3.00	0.22	-0.19	0.94	3.75	1.46	1.18	2.50	0.59	1.27
2.00	All	A	4.95	1.00	0.96	6	0.59	2.04	3.39	0.22	0.06	0.82	3.75	1.46	1.18	2.50	0.59	1.27
		B	5.86	1.21	1.16	8	0.71	2.12	3.52	0.28	-0.15	0.61	4.25	1.78	1.43	3.00	0.71	1.63
2.50	All	A	5.00	1.00	0.96	6	0.59	2.37	3.73	0.22	0.38	1.00	3.75	1.46	1.18	2.50	0.59	1.27
		B	5.92	1.21	1.16	8	0.71	2.43	3.84	0.28	0.17	0.79	4.25	1.78	1.43	3.00	0.71	1.63
3.25	All	A	4.81	1.00	0.96	6	0.59	2.81	4.16	0.22	0.69	1.25	3.75	1.46	1.18	2.50	0.59	1.27
		B	5.73	1.21	1.16	8	0.71	2.81	4.21	0.28	0.48	1.04	4.25	1.78	1.43	3.00	0.71	1.63
		C	7.63	1.43	1.68	12	1.09	3.18	4.82	0.50	0.26	0.82	5.46	2.43	2.18	4.00	1.09	1.69
		D	8.28	1.43	1.53	16	1.09	3.18	5.07	0.66	0.26	0.82	5.46	2.43	2.18	4.00	1.09	1.69
4.00	All	A	4.38	1.00	0.96	6	0.59	3.17	4.53	0.22	0.54	1.46	3.75	1.46	1.18	2.50	0.59	1.27
		B	5.29	1.21	1.16	8	0.71	3.19	4.60	0.28	0.33	1.25	4.25	1.78	1.43	3.00	0.71	1.63
		C	7.19	1.43	1.68	12	1.09	3.57	5.20	0.50	0.11	1.03	5.46	2.43	2.18	4.00	1.09	1.69
		D	7.84	1.43	1.53	16	1.09	3.57	5.46	0.66	0.11	1.03	5.46	2.43	2.18	4.00	1.09	1.69
5.00	All	A	4.31	1.00	0.96	6	0.59	3.75	5.10	0.22	0.86	1.70	3.75	1.46	1.18	2.50	0.59	1.27
		B	5.23	1.21	1.16	8	0.71	3.80	5.20	0.28	0.65	1.49	4.25	1.78	1.43	3.00	0.71	1.63
		C	7.13	1.43	1.68	12	1.09	4.17	5.81	0.50	0.43	1.27	5.46	2.43	2.18	4.00	1.09	1.69
		D	7.78	1.43	1.53	16	1.09	4.17	6.06	0.66	0.43	1.27	5.46	2.43	2.18	4.00	1.09	1.69
6.00	All	A	3.87	1.00	0.96	6	0.59	4.37	5.73	0.22	1.19	2.18	3.75	1.46	1.18	2.50	0.59	1.27
		B	4.79	1.21	1.16	8	0.71	4.42	5.83	0.28	0.98	1.97	4.25	1.78	1.43	3.00	0.71	1.63
		C	6.69	1.43	1.68	12	1.09	4.80	6.43	0.50	0.76	1.75	5.46	2.43	2.18	4.00	1.09	1.69
		D	7.34	1.43	1.53	16	1.09	4.80	6.69	0.66	0.76	1.75	5.46	2.43	2.18	4.00	1.09	1.69
7.00	All	A	3.63	1.00	0.96	6	0.59	4.87	6.23	0.22	1.56	2.19	3.75	1.46	1.18	2.50	0.59	1.27
		B	4.54	1.21	1.16	8	0.71	4.92	6.33	0.28	1.35	1.98	4.25	1.78	1.43	3.00	0.71	1.63
		C	6.44	1.43	1.68	12	1.09	5.30	6.93	0.50	1.13	1.76	5.46	2.43	2.18	4.00	1.09	1.69
		D	7.09	1.43	1.53	16	1.09	5.30	7.19	0.66	1.13	1.76	5.46	2.43	2.18	4.00	1.09	1.69
8.00	All	A	3.63	1.00	0.96	6	0.59	5.50	6.85	0.22	1.87	2.38	3.75	1.46	1.18	2.50	0.59	1.27
		B	4.54	1.21	1.16	8	0.71	5.55	6.95	0.28	1.66	2.17	4.25	1.78	1.43	3.00	0.71	1.63
		C	6.44	1.43	1.68	12	1.09	5.92	7.56	0.50	1.44	1.95	5.46	2.43	2.18	4.00	1.09	1.69
		D	7.09	1.43	1.53	16	1.09	5.92	7.81	0.66	1.44	1.95	5.46	2.43	2.18	4.00	1.09	1.69

¹ Negative values indicate valve block extension beyond rear of cap. Check rear mounting styles (especially pivot mounts) for possible interference with a cap mounted manifold.

Counterbalance Valve Control of Both Extend and Retract Strokes – Dimensions

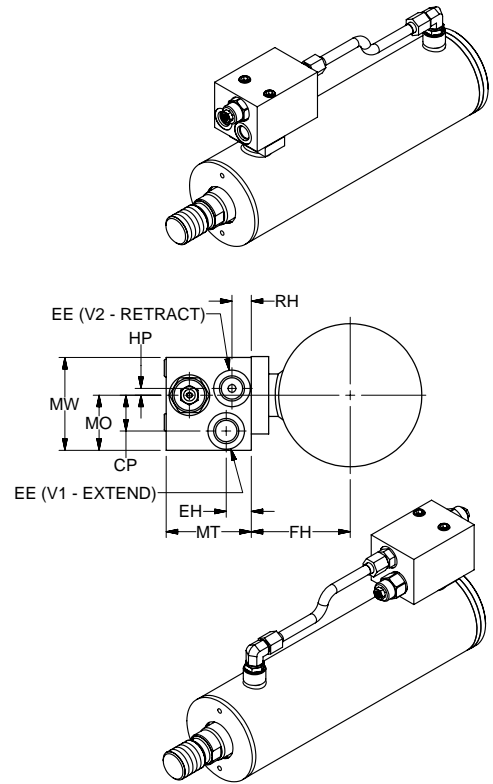
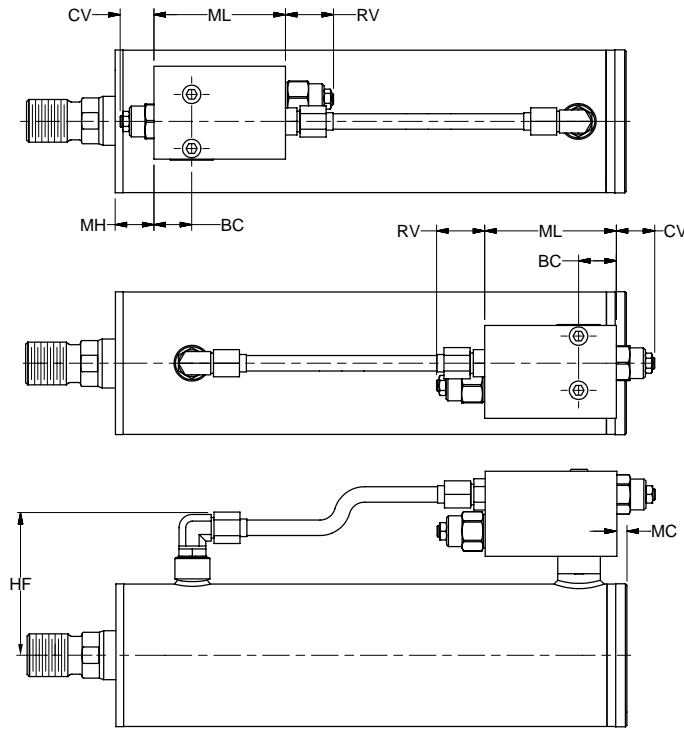

Bore Ø	Rod No.	Manifold Size	Min. Stroke	BC	CP	CV	EE SAE	EH	FH	HF	HP	MC ¹	MH	ML	MO	MT	MW	RH	RV
1.50	1	A	5.50	1.00	0.96	1.28	6	0.59	1.79	3.00	0.25	-0.19	0.56	3.75	1.46	2.18	2.50	0.50	1.27
	2	A	5.50	1.00	0.96	1.28	6	0.59	1.79	3.00	0.25	-0.19	0.94	3.75	1.46	2.18	2.50	0.50	1.27
2.00	All	A	4.95	1.00	0.96	1.28	6	0.59	2.04	3.39	0.25	0.06	0.82	3.75	1.46	2.18	2.50	0.50	1.27
		B	5.86	1.21	1.16	1.32	8	0.81	2.12	3.52	0.22	-0.15	0.61	4.25	1.78	2.75	3.00	0.62	1.63
2.50	All	A	5.00	1.00	0.96	1.28	6	0.59	2.37	3.73	0.25	0.38	1.00	3.75	1.46	2.18	2.50	0.50	1.27
		B	5.92	1.21	1.16	1.32	8	0.81	2.43	3.84	0.22	0.17	0.79	4.25	1.78	2.75	3.00	0.62	1.63
3.25	All	A	4.81	1.00	0.96	1.28	6	0.59	2.81	4.16	0.25	0.69	1.25	3.75	1.46	2.18	2.50	0.50	1.27
		B	5.73	1.21	1.16	1.32	8	0.81	2.81	4.21	0.22	0.48	1.04	4.25	1.78	2.75	3.00	0.62	1.63
		C	7.63	1.43	1.68	1.69	12	1.43	3.18	4.82	0.00	0.26	0.82	5.46	2.43	3.93	4.00	1.18	1.69
		D	8.28	1.43	1.53	1.69	16	1.93	3.18	5.07	0.35	0.26	0.82	5.46	2.43	3.93	4.00	1.09	1.69
4.00	All	A	4.38	1.00	0.96	1.28	6	0.59	3.17	4.53	0.25	0.54	1.46	3.75	1.46	2.18	2.50	0.50	1.27
		B	5.29	1.21	1.16	1.32	8	0.81	3.19	4.60	0.22	0.33	1.25	4.25	1.78	2.75	3.00	0.62	1.63
		C	7.19	1.43	1.68	1.69	12	1.43	3.57	5.20	0.00	0.11	1.03	5.46	2.43	3.93	4.00	1.18	1.69
		D	7.84	1.43	1.53	1.69	16	1.93	3.57	5.46	0.35	0.11	1.03	5.46	2.43	3.93	4.00	1.09	1.69
5.00	All	A	4.31	1.00	0.96	1.28	6	0.59	3.75	5.10	0.25	0.86	1.70	3.75	1.46	2.18	2.50	0.50	1.27
		B	5.23	1.21	1.16	1.32	8	0.81	3.80	5.20	0.22	0.65	1.49	4.25	1.78	2.75	3.00	0.62	1.63
		C	7.13	1.43	1.68	1.69	12	1.43	4.17	5.81	0.00	0.43	1.27	5.46	2.43	3.93	4.00	1.18	1.69
		D	7.78	1.43	1.53	1.69	16	1.93	4.17	6.06	0.35	0.43	1.27	5.46	2.43	3.93	4.00	1.09	1.69
6.00	All	A	3.87	1.00	0.96	1.28	6	0.59	4.37	5.73	0.25	1.19	2.18	3.75	1.46	2.18	2.50	0.50	1.27
		B	4.79	1.21	1.16	1.32	8	0.81	4.42	5.83	0.22	0.98	1.97	4.25	1.78	2.75	3.00	0.62	1.63
		C	6.69	1.43	1.68	1.69	12	1.43	4.80	6.43	0.00	0.76	1.75	5.46	2.43	3.93	4.00	1.18	1.69
		D	7.34	1.43	1.53	1.69	16	1.93	4.80	6.69	0.35	0.76	1.75	5.46	2.43	3.93	4.00	1.09	1.69
7.00	All	A	3.63	1.00	0.96	1.28	6	0.59	4.87	6.23	0.25	1.56	2.19	3.75	1.46	2.18	2.50	0.50	1.27
		B	4.54	1.21	1.16	1.32	8	0.81	4.92	6.33	0.22	1.35	1.98	4.25	1.78	2.75	3.00	0.62	1.63
		C	6.44	1.43	1.68	1.69	12	1.43	5.30	6.93	0.00	1.13	1.76	5.46	2.43	3.93	4.00	1.18	1.69
		D	7.09	1.43	1.53	1.69	16	1.93	5.30	7.19	0.35	1.13	1.76	5.46	2.43	3.93	4.00	1.09	1.69
8.00	All	A	3.63	1.00	0.96	1.28	6	0.59	5.50	6.85	0.25	1.87	2.38	3.75	1.46	2.18	2.50	0.50	1.27
		B	4.54	1.21	1.16	1.32	8	0.81	5.55	6.95	0.22	1.66	2.17	4.25	1.78	2.75	3.00	0.62	1.63
		C	6.44	1.43	1.68	1.69	12	1.43	5.92	7.56	0.00	1.44	1.95	5.46	2.43	3.93	4.00	1.18	1.69
		D	7.09	1.43	1.53	1.69	16	1.93	5.92	7.81	0.35	1.44	1.95	5.46	2.43	3.93	4.00	1.09	1.69

¹ Negative values indicate valve block extension beyond rear of cap. Check rear mounting styles (especially pivot mounts) for possible interference with a cap mounted manifold.

Notes

Notes

C

Theoretical Push Forces for Cylinders

Cylinder Bore Ø	Piston Area (In. ²)	Cylinder Push Stroke Force in Pounds at Various Pressures (psi)						
		100	250	500	1000	1500	2000	3000
1.50	1.77	177	443	885	1770	2651	3540	5310
2.00	3.14	314	785	1570	3140	4712	6280	9420
2.50	4.91	491	1228	2455	4910	7363	9820	14730
3.25	8.30	830	2075	4150	8300	12444	16600	24900
4.00	12.57	1257	3143	6285	12570	18850	25140	37710
5.00	19.64	1964	4910	9820	19640	29453	39280	58920
6.00	28.27	2827	7068	14135	28270	42412	56540	84810
7.00	38.49	3849	9623	19245	38490	57727	76980	115470
8.00	50.27	5027	12568	25135	50270	75398	100540	150810

General Formula

The cylinder output forces are derived from the formula:

$$F = P \times A$$

Where F = Force in pounds.

P = Pressure at the cylinder in pounds per square inch, gauge.

A = Effective area of cylinder piston in square inches.

Theoretical Pull Forces for Cylinders

Bore Ø	Piston Rod Ø	Piston Rod Area (In. ²)	Cylinder Pull Force in Pounds at Various Pressures (psi)						
			100	250	500	1000	1500	2000	3000
1.50	0.625	0.307	146	365	730	1460	2190	2920	4380
	1.000	0.785	98	245	491	982	1473	1964	2946
2.00	1.000	0.785	236	589	1178	2355	3533	4710	7065
	1.375	1.48	166	414	828	1655	2483	3310	4965
2.50	1.000	0.785	413	1031	2063	4125	6188	8250	12375
	1.375	1.48	343	856	1713	3425	5138	6850	10275
	1.750	2.41	250	625	1250	2500	3750	5000	7500
3.25	1.375	1.48	682	1704	3408	6815	10223	13630	20445
	1.750	2.41	589	1473	2945	5890	8835	11780	17670
	2.000	3.14	516	1290	2580	5160	7740	10320	15480
4.00	1.750	2.41	1016	2540	5080	10160	15240	20320	30480
	2.000	3.14	943	2358	4715	9430	14145	18860	28290
	2.500	4.91	766	1915	3830	7660	11490	15320	22980
5.00	2.000	3.14	1650	4125	8250	16500	24750	33000	49500
	2.500	4.91	1473	3683	7365	14730	22095	29460	44190
	3.000	7.07	1257	3143	6285	12570	18855	25140	37710
	3.500	9.62	1002	2505	5010	10020	15030	20040	30060
6.00	2.500	4.91	2336	5840	11680	23360	35040	46720	70080
	3.000	7.07	2120	5300	10600	21200	31800	42400	63600
	3.500	9.62	1865	4663	9325	18650	27975	37300	55950
	4.000	12.57	1570	3925	7850	15700	23550	31400	47100
7.00	3.000	7.07	3142	7855	15710	31420	47130	62840	94260
	3.500	9.62	2887	7218	14435	28870	43305	57740	86610
	4.000	12.57	2592	6480	12960	25920	38880	51840	77760
	4.500	15.90	2259	5648	11295	22590	33885	45180	67770
	5.000	19.63	1886	4715	9430	18860	28290	37720	56580
8.00	3.500	9.62	4065	10163	20325	40650	60975	81300	121950
	4.000	12.57	3770	9425	18850	37700	56550	75400	113100
	4.500	15.90	3437	8593	17185	34370	51555	68740	103110
	5.000	19.63	3064	7660	15320	30640	45960	61280	91920
	5.500	23.76	2651	6628	13255	26510	39765	53020	79530

Cylinder Weights

The estimated weights shown below are for standard Series RDH hydraulic cylinders equipped with the different piston rod diameters. To determine the total net weight of a cylinder, first select the Basic Weight

for the proper mount at zero stroke, then calculate the weight of the cylinder stroke and add the result to the Basic Weight. For extra rod extension, use piston rod weight per inch shown in Table B.

Table A – Series RDH Cylinder Weights in pounds.

Bore Ø	Rod No.	MM Rod Ø	Single Rod Cylinders					Add per Inch of Stroke
			Base Weight at Zero Stroke					
			T	B, BB, SB/SBM, TT	DD	J/JP	H	
1.50	1	0.625	2.5	3.7	5.6	3.8	3.4	0.37
	2	1.000	2.7	3.9	5.8	4.0	3.6	0.50
2.00	1	1.000	5.0	6.6	9.7	7.3	6.4	0.59
	2	1.375	5.4	7.0	10.1	7.7	6.8	0.78
2.50	1	1.000	8.8	11.3	13.7	12.5	11.3	0.83
	2	1.750	9.4	11.9	14.3	13.2	12.0	1.29
	3	1.375	9.8	12.3	14.7	13.6	12.3	1.03
3.25	1	1.375	16.5	22.5	24.9	23.6	21.7	1.41
	2	2.000	17.2	23.2	25.6	24.2	22.4	1.88
	3	1.750	17.8	23.8	26.2	24.8	23.0	1.67
4.00	1	1.750	22.3	28.3	31.4	34.4	31.4	1.83
	2	2.500	24.0	30.0	33.1	36.1	33.1	2.54
	3	2.000	24.7	30.7	33.8	36.7	33.8	2.04
5.00	1	2.000	51.2	57.2	67.7	69.8	66.0	2.68
	2	3.500	52.9	58.9	69.4	71.5	67.7	4.51
	3	2.500	54.6	60.6	71.1	73.2	69.4	3.18
	4	3.000	56.8	62.8	73.3	75.4	71.6	3.79
6.00	1	2.500	75.7	83.7	102.8	106.5	100.9	4.28
	2	4.000	79.7	87.7	106.8	110.5	104.9	6.45
	3	3.000	81.9	89.9	109.0	112.7	107.2	4.89
	4	3.500	83.6	91.6	110.7	114.4	108.8	5.61
7.00	1	3.000	111.8	124.8	154.0	151.8	141.7	5.33
	2	5.000	116.1	129.1	158.3	156.1	146.0	8.89
	3	3.500	118.0	131.0	160.2	158.0	147.9	6.06
	4	4.000	122.0	135.0	164.2	162.0	151.9	6.89
	5	4.500	126.1	139.1	168.3	166.1	156.0	7.83
8.00	1	3.500	159.6	173.6	217.4	216.7	204.5	7.52
	2	5.500	166.9	180.9	224.7	224.0	211.8	11.52
	3	4.000	171.4	185.4	229.2	228.5	216.3	8.35
	4	4.500	175.5	189.5	233.3	232.6	220.4	9.29
	5	5.000	179.8	193.8	237.6	236.9	224.7	10.35

Table B – Extra weight for longer than standard rod extensions

Rod Ø	Piston Rod Weight per Inch (lb)	Rod Ø	Piston Rod Weight per Inch (lb)
0.625	0.09	3.000	2.00
1.000	0.22	3.500	2.72
1.375	0.42	4.000	3.56
1.750	0.68	4.500	4.50
2.000	0.89	5.000	5.56
2.500	1.39	5.500	6.72

Seal Information

Operating Fluids and Temperature Range

Fluidpower cylinders are designed for use with pressurized air, hydraulic oil and fire resistant fluids; in some cases special seals are required.

Standard Seals (class 1)

Class 1 seals are what is normally provided in a cylinder unless otherwise specified. They are intended for use with fluids such as: air, nitrogen, mineral base hydraulic oil or MIL-H-5606 within the temperature range of -10°F (-23°C) to +165°F (+74°C). The individual seals may be nitrile (Buna-N), enhanced polyurethane, polymyte, P.T.F.E. or filled P.T.F.E.

Water Base Fluid Seals (class 2)

Generally class 2 seals are intended for use with water base fluids within the temperature of -10°F (-23°C) to +165°F (+74°C) except for High Water Content Fluids (H.W.C.F.) in which case Class 6 seals should be used. Typical water base fluids are: Water, Water-Glycol, Water-in Emulsion, Houghto-Safe 27, 620, 5040, Mobil Pyrogard D, Shell Iruis 905, Ucon Hydrolube J-4. These seals are nitrile. Rod seal and piston seal will have polymyte or P.T.F.E. back-up washer when required. Piston seal may be filled P.T.F.E. O-rings will have nitrile back-up washers when required.

Ethylene Propylene (E.P.R.) Seals (class 3)

Class 3 seals are intended for use with some Phosphate Ester Fluids between the temperatures of -10°F (-23°C) to +130°F (+54°C). Typical fluids compatible with E.P.R. seals are Skydrol 500 and 700. E.P.R. are Ethylene Propylene. Rod seal and piston seal will have a P.T.F.E. back-up washer when required. Piston seal may be filled P.T.F.E. O-rings will have EPR back-up washers when required. **Note:** E.P.R. seals are not compatible with mineral base hydraulic oil or greases. Even limited exposure to these fluids will cause severe swelling. P.T.F.E. back-up washer may not be suitable when used in a radiation environment.

Low Temperature Nitrile Seals (class 4)

Class 4 seals are intended for low temperature service with the same type of fluids as used with Class 1 seals within the temperature range of -50°F (-46°C) to +150°F (+66°C). Rod seal and piston seal will have leather, polymyte or P.T.F.E. back-up washers when required. Piston seal may be filled P.T.F.E. O-rings will have nitrile back-up washers when required. **Note:** Certain fluids may react adversely with Class 4 seals compared to Class 1 seals.

Fluorocarbon Seals (class 5)

Class 5 seals are intended for elevated temperature service or for some Phosphate Ester Fluids such as Houghto-Safe 1010, 1055, 1120; Fyrquel 150, 220, 300, 350; Mobile Pyrogard 42, 43, 53, and 55. **Note:** In addition, class 5 seals can be used with fluids listed on the next page under standard service. However, they are not compatible with Phosphate Ester Fluids such as Skydrols. Class 5 seals can operate with a temperature range of -10°F (-23°C) to +250°F (+121°C). Class 5 seals may be operated to +400°F (+204°C) with limited service life. For temperatures above +250°F (+121°C) the cylinder must be manufactured with non-studded piston rod and thread and a pinned piston to rod connection. Class 5 rod seal and piston seal will have P.T.F.E. back-up washers when required. Piston seal may be filled P.T.F.E. O-rings will have fluorocarbon back-up when required.

H.W.C.F. Seals (class 6)

Class 6 seals are intended for High Water Content Fluids (H.W.C.F.) such as Houghton, Hydrolubric 120B and Sonsel Lubrizol within the temperature range of +40°F (+4°C) to +120°F (+49°C). Class 6 seals are the same as Class 2 seals. Rod seal and piston seal will have P.T.F.E. and or polymyte back-up washers when required. Piston seal may be filled P.T.F.E. O-rings will have nitrile back-up washers when required.

Energized PTFE Seals (class 8)

Class 8 seals consist of PTFE rod seals, rod wiper seal and piston seal. All seals have o-ring energizers for sealing in static

Heavy Duty Hydraulic Roundline Cylinders Engineering Data

and dynamic applications. They are intended for high temperature applications, to 400°F (204°C), where longer seal life and improved high temperature sealing performance is required. End seal and energizer o-ring seals will be fluorocarbon. Fluid resistance is comparable to Class 5. Cylinders incorporating Class 8 Seals will not have studded piston rods.

Warning

The piston rod stud and the piston rod to piston threaded connections are secured with an anaerobic adhesive which is temperature sensitive. Cylinders are assembled with anaerobic adhesive having a maximum temperature rating of +250°F (+121°C). Cylinders specified with all other seal compounds (built before 1997) were assembled with anaerobic adhesive having a maximum operating temperature rating +165°F (+74°C). These temperature limitations are necessary to prevent the possible loosening of the threaded connections. Cylinders originally manufactured (before 1997) with class 1 seals (Nitrile) that will be exposed to ambient temperatures above +165°F (+74°C) must be modified for higher temperature service. Contact the factory immediately and arrange for the piston to rod and the stud to piston rod connections to be properly re-assembled to withstand the higher temperature service.

Hi-Load Seals

Hi-load seals consist of one PTFE dynamic piston seal with an energizer underneath. Hi-load piston arrangement includes a wear ring on the piston. The piston seal is virtually leak-free under static conditions and can tolerate high pressure. The wear ring on the piston can also tolerate high side loads. The dynamic portion of the seal is bronze filled PTFE and compatible with all conditions and fluids listed on this page. However, carbon filled PTFE will provide better seal life when used with class 6 fluids. A nitrile expander will be provided unless Class 3 or 5 seals are specified. In those cases the expander will be of E.P.R. or fluorocarbon respectively. **Note:** It may be necessary to cycle the piston seals 40 or 50 times before achieving leakage free performance.

Low Friction Hydraulic Seals

Low friction hydraulic seals are available as an option. They are sometimes used when a cylinder is controlled by a servo valve or proportional valve. The rod seals, rod wiper seal and piston seal are two-piece assemblies that include a filled PTFE dynamic seal with an o-ring energizer. The piston and head also include WearGard™ wear rings. The filled PTFE seals are compatible with the fluids listed on this page and provide virtually leak-free sealing. The energizers will be fluorocarbon unless E.P.R. seals are specified. In those cases the energizers will be E.P.R. **Note:** It may be necessary to cycle these seals 40 or 50 times before achieving leakage free performance.

Water Service

Series RDH cylinders can be modified to make them more suitable for use with water as the operating medium. The modifications include chrome-plated cylinder bore; electroless nickel-plated head, cap and piston; and a chrome plated 17-4 stainless steel piston rod.

When high water base fluids are the operating medium, hydraulic cylinders are usually supplied with high water base rod wiper and seals. Water and high water base fluid operated cylinders are best used on short stroke applications or where high pressure is applied only to clamp the load.

Warranty

Atlas Cylinders will warrant cylinders modified for water or high water content fluid service to be free of defects in materials or workmanship, but cannot accept responsibility of premature failure due to excessive wear from lack of lubricity or where failure is caused by corrosion, electrolysis or mineral deposits within the cylinder.

Fluids and Temperature Range

Class No.	Typical Fluids	Temperature Range
1 (Standard) (Nitrile, Polyurethane)	Air, Nitrogen Hydraulic Oil, Mil-H-5606 Oil	-10°F (-23°C) to +165°F (+74°C)
2 Water Base Fluid Seal	Water, Water-Glycol, Water-in-Oil Emulsion Houghto-Safe, 271, 620, 5040. Mobil Pyrogard D, Shell Iruis 905. Ucon Hydrolube J-4	-10°F (-23°C) to +165°F (+74°C)
3 E.P.R.	Some Phosphate Ester Fluids Skydrol 500, 7000	-10°F (-23°C) to +130°F (+54°C)
Note: (E.P.R.) seals are not compatible with Hydraulic Oil		
4 Nitrile	Low Temperature Air or Hydraulic Oil	-50°F (-46°C) to +150°F (+66°C)
5 Fluorocarbon Seals	High Temperature Houghto-Safe 1010, 1055, 1120 Fyrquel 150, 220, 300, 550 Mobil Pyrogard 42,43,53,55	See paragraph on Fluorocarbon Seals on previous page for recommended temperature range.
Note: Fluorocarbon seals are not suitable for use with Skydrol fluid, but can be used with hydraulic oil if desired.		
6 HWCF (same seals as Class 2)	Houghton, Hydrolubric 120B Sonsol Lubrizol; for other HWCF — consult factory.	+40°F (+4°C) to +120°F (+49°C)
8 Energized PTFE	See Class 5 Seals	-15°F (-26°C) to +400°F (+204°C)

Seal Compounds by Seal Code

Seal Code	Description	Rod Wiper Seal	Rod Seal	Rod Seal Backup Ring	Piston Seal	Piston Seal Energizer	Piston Joint Seal	End Seal	End Seal Backup Ring	Wear Rings
(blank)	Standard (Class 1)	Urethane	Polyurethane	N/A	Polyurethane	Nitrile	Fluorocarbon	Nitrile	Nitrile	Composite
2	Water Base Fluid/HWCF (Classes 2 and 6)	Nitrile	Carboxylated Nitrile	PTFE	Bronze Filled PTFE	Nitrile	Fluorocarbon	Nitrile	Nitrile	Composite
X	EPR (Class 3)	EPR	EPR	PTFE	Bronze Filled PTFE	EPR	EPR	EPR	PTFE	Composite
4	Low Temperature (Class 4)	Urethane	Polyurethane	N/A	Polyurethane	Low Temperature Nitrile	Fluorocarbon	Low Temperature Nitrile	Low Temperature Nitrile	Composite
V	Fluorocarbon (Class 5)	Fluorocarbon	Fluorocarbon	PTFE	Bronze Filled PTFE	Fluorocarbon	Fluorocarbon	Fluorocarbon	Fluorocarbon	Composite
H	Extreme High Temperature (Class 8)	Bronze Filled PTFE with Fluorocarbon Energizer	Bronze Filled PTFE with Fluorocarbon Energizer	N/A	Bronze Filled PTFE	Fluorocarbon	Fluorocarbon	Fluorocarbon	Fluorocarbon	High Temperature Composite
K	Standard (with Bronze Filled PTFE Piston Seal)	Urethane	Polyurethane	N/A	Bronze Filled PTFE	Nitrile	Fluorocarbon	Nitrile	Nitrile	Composite
E	Fluorocarbon Rod Seals Only	Fluorocarbon	Fluorocarbon	PTFE	Polyurethane	Nitrile	Fluorocarbon	Nitrile	Nitrile	Composite
M	Metallic Rod Wiper, Standard Seals	Brass with Fluorocarbon Energizer	Polyurethane	N/A	Polyurethane	Nitrile	Fluorocarbon	Nitrile	Nitrile	Composite
D	Metallic Rod Wiper, Fluorocarbon Seals	Brass with Fluorocarbon Energizer	Fluorocarbon	PTFE	Bronze Filled PTFE	Fluorocarbon	Fluorocarbon	Fluorocarbon	Fluorocarbon	Composite

Ports

Ports

Series RDH cylinders can be supplied with many port styles, but SAE straight o-ring ports are standard. Extra ports are available for an additional charge.

Standard port location is position 1 as shown in the mounting drawings and Figure 1 below. Port locations other than position 1 can be specified for no additional charge if both ports are in the same new position. If either port is required to be at a different position than the other, additional charges would apply.

Figure 1

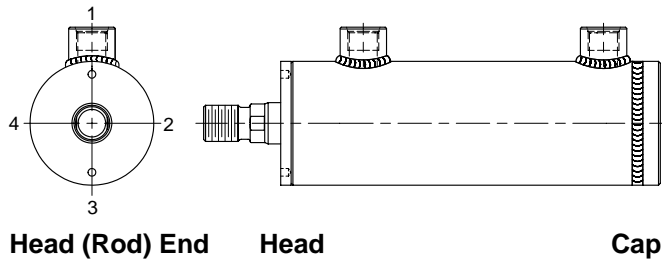

Head (Rod) End

Head

Cap

Straight Thread Ports

The SAE straight thread o-ring port is recommended for hydraulic applications. SAE port size numbers are listed next to the NPTF pipe thread counterparts for each bore size in the respective catalog pages. Size number, tube O.D., and port thread size for SAE ports are listed in Table A.

Table A

SAE Straight Thread O-Ring Ports

Size No.	Tube O.D. (in.)	Thread Size
2	0.13	5/16 - 24
3	0.19	3/8 - 24
4	0.25	7/16 - 20
5	0.31	1/2 - 20
6	0.38	9/16 - 18
8	0.50	3/4 - 16
10	0.63	7/8 - 14
12	0.75	1 1/16 - 12
16	1.00	1 5/16 - 12
20	1.25	1 5/8 - 12
24	1.50	1 7/8 - 12
32	2.00	2 1/2 - 12

Note: For the pressure ratings of individual connectors, contact your connector supplier. Hydraulic cylinders applied with meter out or deceleration circuits are subject to intensified pressure at the cylinder piston rod end. The rod end pressure is approximately equal to:

$$\frac{\text{Effective Cap End Piston Area}}{\text{Effective Rod End Piston Area}} \times \text{Operating Pressure}$$

International Ports

Other port configurations to meet international requirements are available for an additional charge. Series RDH cylinders can be supplied with British standard taper ports (BSPT). Such port has a taper of 1 in 16 measured on the diameter (1/16" per inch). The thread form is Whitworth System, and size and number of threads per inch are as follows:

Table B

British Standard Pipe Threads

Nominal Pipe Size	No. Threads Per Inch	Pipe O.D.
1/8	28	0.383
1/4	19	0.518
3/8	19	0.656
1/2	14	0.825
3/4	14	1.041
1	11	1.309
1 1/4	11	1.650
1 1/2	11	1.882
2	11	2.347

British standard parallel internal threads are designated as BSPP and have the same thread form and number of threads per inch as the BSPT type and can be supplied for an additional charge. Unless otherwise specified, the BSPP or BSPT port size supplied will be the same nominal pipe size as the NPTF port for a given bore size cylinder.

Ports

**SAE 4-Bolt Flange Ports
(Code 61, 3000 psi)**

SAE 4-bolt flange port connections provide the ability to connect larger pipe or hose sizes and achieve higher-pressure capability at reasonable assembly torques. Because of the lower assembly torques compared to an equivalent size threaded port, SAE 4-bolt flange ports are well suited for tight quarters where wrench clearances are limited. See Table A for port mounting flange dimensions and Table B for port flange height dimensions.

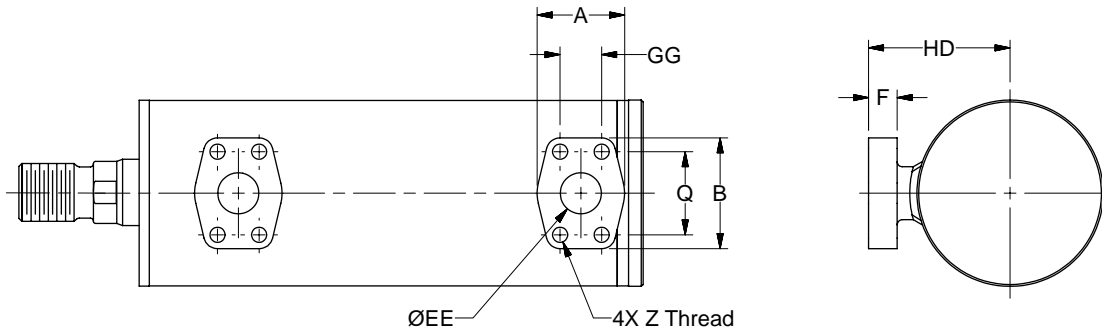
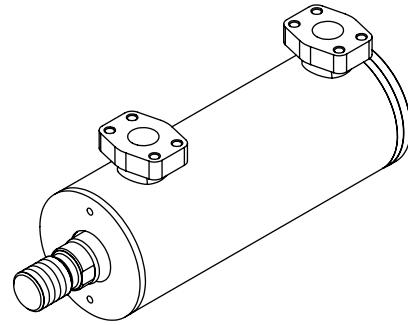

Table A

Flange Size	SAE Dash No.	A	B	GG	Q	F	EE Ø	Z
0.50	8	1.81	2.13	0.69	1.50	0.63	0.548	5/16-18
0.75	12	1.97	2.56	0.88	1.88	0.71	0.744	3/8-16
1.00	16	2.17	2.75	1.03	2.06	0.71	0.959	3/8-16
1.25	20	2.68	3.12	1.19	2.31	0.83	1.280	7/16-14
1.50	24	3.07	3.68	1.41	2.75	0.98	1.502	1/2-13

Table B

Bore Ø	HD				
	Code 61 Flange Size				
	0.50	0.75	1.00	1.25	1.50
1.50	N/A	N/A	N/A	N/A	N/A
2.00	2.52	N/A	N/A	N/A	N/A
2.50	2.85	N/A	N/A	N/A	N/A
3.25	3.29	3.29	3.37	N/A	N/A
4.00	3.65	3.65	3.73	N/A	N/A
5.00	4.23	4.23	4.31	N/A	N/A
6.00	4.85	4.85	4.93	5.04	N/A
7.00	5.35	5.35	5.43	5.54	5.66
8.00	5.98	5.98	6.06	6.17	6.29

Undersize and Oversize Ports

Undersize and oversize ports are available. Please consult factory.

Metric ports can also be supplied to order for an additional charge. See table below for the standard port size for each bore.

Table C – Standard Port Sizes

Bore Ø	U NPTF	T SAE	R BSPP	B BSPT	G Metric	P Flange
1.50	3/8	6	G3/8	Rc3/8	M16x1.5	NA
2.00	1/2	8	G1/2	Rc1/2	M22x1.5	0.50
2.50	1/2	8	G1/2	Rc1/2	M22x1.5	0.50
3.25	3/4	12	G3/4	Rc3/4	M27x2	0.75
4.00	3/4	12	G3/4	Rc3/4	M27x2	0.75
5.00	3/4	12	G3/4	Rc3/4	M27x2	0.75
6.00	1	16	G1	Rc1	M33x2	1.00
7.00	1 1/4	20	G1-1/4	Rc1-1/4	M42x2	1.25
8.00	1 1/4	20	G1-1/4	Rc1-1/4	M42x2	1.50

Stroke Data

Series RDH cylinders are available in any practical stroke length.

Stroke Length Tolerance

Stroke length tolerances are required due to buildup of tolerances of the piston, head, cap and cylinder tube.

Standard stroke length tolerances are:

for strokes up to 43" = -0/+0.040"

for strokes greater than 43" = -0/+0.062"

For closer tolerances on stroke length, it is necessary to specify the required tolerance plus the pressure and temperature at which the cylinder will operate. Stroke tolerances smaller than .015" are not generally practical due to elasticity of cylinders. If machine design requires such close tolerances, use of a stroke adjuster or special endcap ties may achieve the desired result. Please consult factory.

Fatigue Life

Although each application is unique, all cylinders have a finite life. In general, welded cylinders have a limited fatigue life when used at the maximum pressure rating. Series RDH cylinders are rated for industrial-grade service but for the maximum possible fatigue life in severe duty applications, Atlas Cylinders with another construction style (tie-rod, mill-type or bolted) should be considered. If necessary, consult the factory for assistance.

Note: User Responsibility. The user, through its own analysis and testing, is solely responsible for making the final selection of the system and Product and assuring that all performance, endurance, maintenance, safety and warning requirements of the application are met. The user must analyze all aspects of the application and follow applicable industry standards and Product information. If Seller provides Product or system options, the user is responsible for determining that such data and specifications are suitable and sufficient for all applications and reasonably foreseeable uses of the Products or systems.

Mounting Groups

Standard mountings for Series RDH cylinders fall into two basic groups. The groups can be summarized as follows:

Straight Line Force Transfer – fixed mounts which absorb force on the cylinder centerline

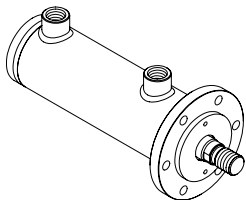

Styles J/JP

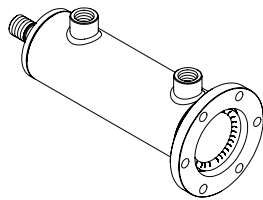

Style H

Pivot Force Transfer – mountings that permit a cylinder to change its alignment in one plane

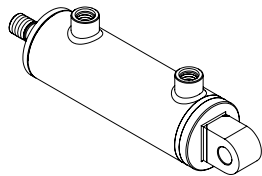

Style B

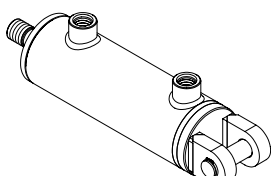

Style BB

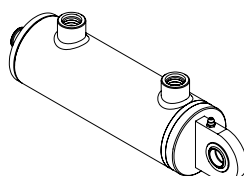

Style SB/SBM

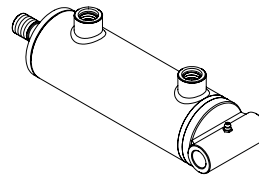

Style TT

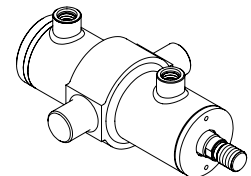

Style DD

The cylinder's mounting directly affects the maximum pressure at which the cylinder can be used. Stroke length, piston rod connection to load, extra piston rod length over standard, etc. should be considered for thrust loads. See Stop Tubing and Piston Rod Selection

Data on the following pages to first determine whether stop tubing is recommended and then determine the correct piston rod diameter for an application. Alloy steel mounting bolts are recommended for all mounting styles.

Stop Tubing

Stop tube is recommended to lengthen the distance between the rod bearing and piston bearing to reduce bearing loads on long push stroke cylinders when the cylinder is fully extended. This is especially true of horizontally mounted cylinders. As part of the piston assembly and positioned between the piston and head, a stop tube restricts the extended position of the rod using the increased distance to achieve additional stability.

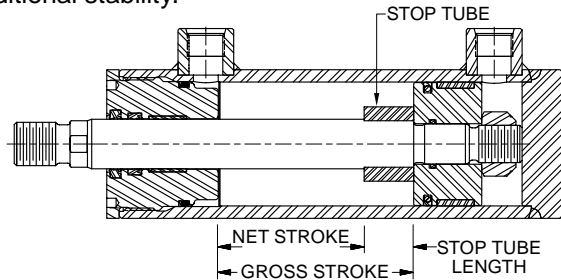

Use the following steps to determine the need for stop tube and, if required, how long it should be.

1. Examine the groups of cylinder illustrations below and determine which mounting and rod guiding group type match the required cylinder application.

2. Establish the Basic Length (L), with the piston rod fully extended, for the selected illustration by using the dimensional tables on previous pages of this catalog. For pivot mounted cylinders, the pin-to-pin dimension with the piston rod fully extended must be used. Regardless of mounting style, be sure to include any extended piston rod length beyond the catalog standard.
3. In the Stop Tube Table select the column for the appropriate mounting style and rod end guiding type. In the Basic Length (L) column, find the row with the range that includes the value calculated in Step 2. The next respective column to the right has the required length of stop tube.

Note: Mounting Styles B, BB, SB/SBM, TT and H that are mounted horizontally should also be checked for turning moments and loads between the rod bearing and piston to ensure they are not excessive. Weight of oil must be included in determining bearing loads.

When specifying cylinders with stop tube be sure to call out the net stroke and the length of the stop tube. Machine design can be continued without delay by laying in a cylinder equivalent in length to the NET STROKE PLUS STOP TUBE LENGTH, which is referred to as GROSS STROKE.

Stop Tube Table

Pivot Mounts (B, BB, SB/SBM, TT and DD)		Fixed Mounts (J/JP and H)						
Pivoted and Rigidly Guided Rod End		Fixed and Rigidly Guided Rod End		Pivoted and Rigidly Guided Rod End		Unguided Rod End		
Basic Length (L)	Stop Tube Length	Basic Length (L)	Stop Tube Length	Basic Length (L)	Stop Tube Length	Basic Length (L)	Stop Tube Length	
0 - 40	0	0 - 80	0	0 - 57	0	0 - 20	0	
41 - 50	1	81 - 100	1	58 - 71	1	21 - 25	1	
51 - 60	2	101 - 120	2	72 - 86	2	26 - 30	2	
61 - 70	3	121 - 140	3	87 - 100	3	31 - 35	3	
71 - 80	4	141 - 160	4	101 - 114	4	36 - 40	4	
81 - 90	5	161 - 180	5	115 - 129	5	41 - 45	5	
91 - 100	6	181 - 200	6	130 - 143	6	46 - 50	6	
101 - 110	7	201 - 220	7	144 - 157	7	51 - 55	7	
111 - 120	8	221 - 240	8	158 - 171	8	56 - 60	8	
121 - 130	9	241 - 260	9	172 - 186	9	61 - 65	9	
131 - 140	10	261 - 280	10	187 - 200	10	66 - 70	10	
141 - 150	11	281 - 300	11	201 - 214	11	71 - 75	11	
151 - 160	12	Consult Factory		215 - 229	12	76 - 80	12	
161 - 170	13			230 - 243	13	81 - 85	13	
171 - 180	14			244 - 257	14	86 - 90	14	
181 - 190	15			258 - 271	15	91 - 95	15	
191 - 200	16			272 - 286	16	96 - 100	16	
201 - 210	17			287 - 300	17	101 - 105	17	
211 - 220	18					106 - 110	18	
221 - 230	19					111 - 115	19	
231 - 240	20					116 - 120	20	
241 - 250	21					121 - 125	21	
251 - 260	22					126 - 130	22	
261 - 270	23					131 - 135	23	
271 - 280	24					136 - 140	24	
281 - 290	25					141 - 145	25	
291 - 300	26					146 - 150	26	
Consult Factory							Consult Factory	

Cylinder Mounting and Rod Guiding Groups

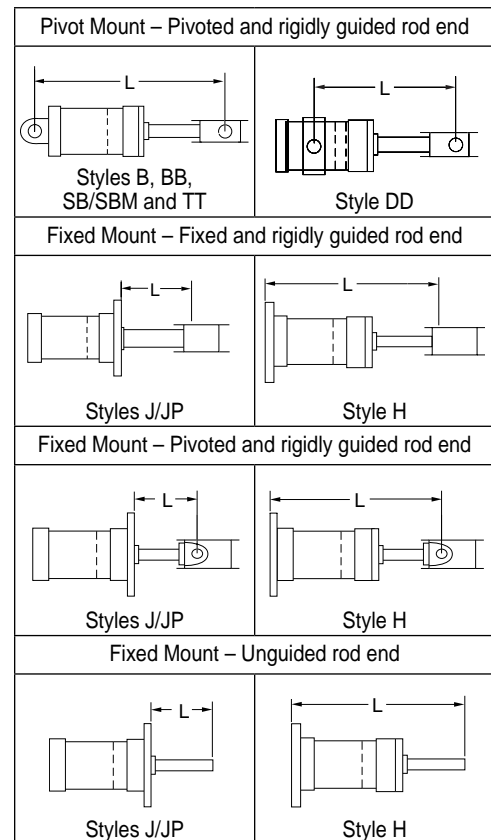

Piston Rod Diameter Selection

Long stroke cylinders that work on push with the piston rod loaded in compression should be checked, using the following steps, to ensure an appropriate piston rod diameter is specified.

1. First, determine whether stop tubing is required as described on the previous page.
2. Use the Basic Length (L) that was established for determining the stop tube length and then add the required stop tube length to the Basic Length to obtain an Adjusted Basic Length (L_A).
3. In the table below, for the mounting style and rod end guiding condition that will be used, find the row for the Bore and Rod combination that is required.
4. Follow the Bore and Rod row to the right and find the Operating Pressure column that is closest, but

exceeds the system pressure. The intersection of the Bore and Rod row and Operating Pressure column displays the maximum allowable L_A. If L_A in the table is greater than or equal to the calculated L_A, the rod diameter selected is satisfactory for the application.

5. If L_A in the table is less than the calculated Adjusted Basic Length move down the column to a rod diameter with an L_A that exceeds the requirement.
6. If the L_A specifies a rod diameter in a larger bore then restart the process of sizing the stop tube and re-check the rod diameter. Contact the factory if L_A exceeds 300 inches.

Note: Data in these tables assume standard rod extension (W dimension) and standard rod end accessories. If different, consult factory.

Maximum Basic Lengths (L_A) (all dimensions in inches)

Bore Ø	Rod Ø	Rear Pivot Mounts (B, BB, SB ¹ , SBM and TT)						Front Fixed Mount (J)																	
		Pivoted and Rigidly Guided Rod End Max. Allowable Basic Length (L _A) at psi:						Fixed and Rigidly Guided Rod End Max. Allowable Basic Length (L _A) at psi:						Pivoted and Rigidly Guided Rod End Max. Allowable Basic Length (L _A) at psi:						Unguided Rod End Max. Allowable Basic Length (L _A) at psi:					
		500	1000	1500	2000	2500	3000	500	1000	1500	2000	2500	3000	500	1000	1500	2000	2500	3000	500	1000	1500	2000	2500	3000
1.50	0.625	35	25	20	18	16	14	50	39	26	29	20	19	35	25	20	17	16	14	12	8	7	6	5	5
	1.000	85	60	49	42	38	35	128	90	73	64	57	52	91	64	52	45	40	37	31	22	18	15	14	12
2.00	1.000	66	47	38	33	29	27	95	67	55	47	42	38	68	48	39	33	30	27	23	16	13	11	10	9
	1.375	116	82	67	58	52	47	181	127	104	90	80	73	129	91	74	64	57	52	44	31	25	22	19	17
2.50	1.000	54	38	31	27	24	22	76	53	43	37	33	30	54	38	31	26	23	21	18	12	10	8	7	7
	1.375	99	70	57	49	44	40	144	102	83	71	64	58	103	72	59	51	45	41	35	24	20	17	15	13
	1.750	151	106	87	75	67	61	234	165	135	117	104	95	167	118	96	83	74	67	58	40	33	28	25	23
3.25	1.375	78	55	45	39	35	32	111	78	63	55	49	44	79	55	45	39	34	31	27	18	15	13	11	10
	1.750	123	87	71	62	55	50	180	127	103	89	80	72	128	90	73	63	56	51	44	31	25	21	19	17
	2.000	157	111	90	78	70	64	235	166	135	117	105	95	168	118	96	83	74	68	58	40	33	28	25	23
4.00	1.750	102	72	59	51	45	41	146	103	84	72	64	59	104	73	59	51	46	41	35	25	20	17	15	14
	2.000	131	92	75	65	58	53	191	134	109	95	84	77	136	96	78	67	60	54	46	32	26	22	20	18
	2.500	194	137	112	97	87	79	299	211	172	149	133	121	213	150	122	106	95	86	74	52	42	36	32	29
5.00	2.000	107	76	62	53	48	44	152	107	87	75	67	61	108	76	62	53	47	43	37	26	21	18	16	14
	2.500	163	115	94	82	73	67	239	168	137	119	106	97	170	120	98	84	75	68	58	41	33	28	25	23
	3.000	226	160	130	113	101	92	300	243	198	171	153	140	246	173	141	122	109	99	85	60	48	42	37	34
	3.500	289	204	167	145	129	118	300	300	270	234	209	191	300	236	193	167	149	136	116	82	66	57	51	46
6.00	2.500	139	98	80	70	62	57	199	140	114	99	88	80	142	100	81	70	62	57	48	34	27	23	21	19
	3.000	197	139	114	98	88	80	287	202	165	143	127	116	205	144	117	101	91	83	71	49	40	34	31	28
	3.500	260	184	150	130	116	106	300	276	225	195	174	159	279	197	160	139	124	113	97	68	55	47	42	38
	4.000	300	231	188	163	146	133	300	300	295	255	228	208	300	258	210	182	162	148	127	89	72	63	56	51
7.00	3.000	171	121	99	85	76	70	246	173	141	122	109	99	175	123	100	87	77	71	60	42	34	29	26	24
	3.500	228	161	132	114	102	93	300	236	193	167	149	136	239	168	137	119	106	97	83	58	47	40	36	33
	4.000	289	204	167	145	129	118	300	300	252	218	195	178	300	221	180	155	139	127	108	76	62	53	48	43
	4.500	300	249	203	176	157	144	300	300	300	277	247	226	300	280	228	197	176	161	138	97	79	68	61	55
	5.000	300	293	239	207	185	169	300	300	300	300	300	279	300	300	282	244	218	199	170	120	98	84	75	69
8.00	3.500	203	144	117	102	91	83	293	207	169	146	130	119	209	147	120	104	93	84	72	51	41	35	31	29
	4.000	261	185	151	131	117	107	300	271	221	191	171	156	273	193	157	136	121	111	95	66	54	47	41	38
	4.500	300	229	187	162	145	132	300	300	280	242	216	197	300	244	199	172	154	140	120	85	69	59	53	48
	5.000	300	274	224	194	174	158	300	300	300	299	267	244	300	300	246	213	191	174	149	105	85	74	66	60
	5.500	300	300	261	226	202	185	300	300	300	300	300	295	300	300	298	258	231	211	180	127	103	89	80	73

¹ Maximum operating pressure is limited for the SB Mount. Please refer to maximum operating pressure per bore in SB Pressure Ratings table on page 14.

Maximum Basic Lengths (L_A) (all dimensions in inches)

Bore Ø	Rod Ø	Intermediate Pivot Mount (DD)						Rear Fixed Mount (H)																	
		Pivoted and Rigidly Guided Rod End Max. Allowable Basic Length (L _A) at psi:						Fixed and Rigidly Guided Rod End Max. Allowable Basic Length (L _A) at psi:						Pivoted and Rigidly Guided Rod End Max. Allowable Basic Length (L _A) at psi:						Unguided Rod End Max. Allowable Basic Length (L _A) at psi:					
		500	1000	1500	2000	2500	3000	500	1000	1500	2000	2500	3000	500	1000	1500	2000	2500	3000	500	1000	1500	2000	2500	3000
1.50	0.625	25	18	14	13	11	10	70	50	40	35	31	29	50	35	29	25	22	20	18	12	10	9	8	7
	1.000	64	45	37	32	29	26	170	120	98	85	76	69	121	86	70	61	54	50	42	30	25	21	19	17
2.00	1.000	48	34	28	24	22	20	132	93	76	66	59	54	94	67	54	47	42	38	33	23	19	16	15	13
	1.375	91	64	53	45	41	37	232	164	134	116	104	95	166	117	96	83	74	68	58	41	33	29	26	24
2.50	1.000	38	27	22	19	17	16	107	76	62	54	48	44	77	54	44	38	34	31	27	19	16	13	12	11
	1.375	73	51	42	36	33	30	197	140	114	99	88	81	141	100	81	70	63	58	49	35	28	25	22	20
	1.750	118	83	68	59	53	48	300	213	174	151	135	123	215	152	124	108	96	88	75	53	43	38	34	31
3.25	1.375	56	40	32	28	25	23	156	110	90	78	70	64	111	79	64	56	50	45	39	28	22	19	17	16
	1.750	91	64	52	45	41	37	246	174	142	123	110	100	176	124	102	88	79	72	62	44	36	31	28	25
	2.000	118	84	68	59	53	48	300	221	181	157	140	128	224	158	129	112	100	91	78	55	45	39	35	32
4.00	1.750	74	52	43	37	33	30	203	144	117	102	91	83	145	103	84	73	65	59	51	36	29	25	23	21
	2.000	96	68	56	48	43	39	261	185	151	131	117	107	187	132	108	93	83	76	65	46	38	33	29	27
	2.500	150	106	87	75	67	61	300	274	224	194	173	158	277	196	160	138	124	113	97	69	56	48	43	40
5.00	2.000	77	54	44	38	34	31	214	151	123	107	96	87	153	108	88	76	68	62	53	38	31	27	24	22
	2.500	120	85	69	60	54	49	300	231	188	163	146	133	233	165	135	117	104	95	82	58	47	41	36	33
	3.000	173	122	100	87	77	71	300	300	261	226	202	184	300	228	186	161	144	132	113	80	65	56	50	46
	3.500	236	167	136	118	105	96	300	300	300	289	259	236	300	292	239	207	185	169	145	102	83	72	65	59
6.00	2.500	100	71	58	50	45	41	278	197	161	139	124	114	199	141	115	99	89	81	70	49	40	35	31	28
	3.000	144	102	83	72	65	59	300	278	227	197	176	161	281	199	162	140	126	115	98	70	57	49	44	40
	3.500	196	139	113	98	88	80	300	300	300	260	233	212	300	263	215	186	166	152	130	92	75	65	58	53
	4.000	257	181	148	128	115	105	300	300	300	300	292	266	300	300	269	233	208	190	163	115	94	82	73	67
7.00	3.000	124	87	71	62	55	50	300	241	197	171	153	139	244	172	141	122	109	100	85	60	49	43	38	35
	3.500	168	119	97	84	75	69	300	300	263	228	204	186	300	230	188	163	146	133	114	81	66	57	51	46
	4.000	220	155	127	110	98	90	300	300	300	289	259	236	300	292	239	207	185	169	145	102	83	72	65	59
	4.500	278	197	161	139	124	114	300	300	300	300	300	288	300	300	290	252	225	205	176	124	102	88	79	72
	5.000	300	243	198	172	154	140	300	300	300	300	300	300	300	300	300	296	264	241	207	146	119	103	93	84
8.00	3.500	147	104	85	74	66	60	300	288	235	203	182	166	291	205	168	145	130	119	102	72	59	51	45	42
	4.000	192	136	111	96	86	79	300	300	300	261	234	213	300	264	216	187	167	152	131	92	75	65	58	53
	4.500	244	172	141	122	109	99	300	300	300	300	290	264	300	300	267	231	207	189	162	114	93	81	72	66
	5.000	300	213	174	150	134	123	300	300	300	300	300	300	300	300	300	277	248	226	194	137	112	97	87	79
	5.500	300	257	210	182	163	149	300	300	300	300	300	300	300	300	300	300	289	264	226	160	131	113	101	92



Safety Guide for Selecting and Using Hydraulic, Pneumatic Cylinders and Their Accessories

WARNING: ⚠ FAILURE OF THE CYLINDER, ITS PARTS, ITS MOUNTING, ITS CONNECTIONS TO OTHER OBJECTS, OR ITS CONTROLS CAN RESULT IN:

- Unanticipated or uncontrolled movement of the cylinder or objects connected to it.
- Falling of the cylinder or objects held up by it.
- Fluid escaping from the cylinder, potentially at high velocity.

THESE EVENTS COULD CAUSE DEATH OR PERSONAL INJURY BY, FOR EXAMPLE, PERSONS FALLING FROM HIGH LOCATIONS, BEING CRUSHED OR STRUCK BY HEAVY OR FAST MOVING OBJECTS, BEING PUSHED INTO DANGEROUS EQUIPMENT OR SITUATIONS, OR SLIPPING ON ESCAPED FLUID.

Before selecting or using Parker Hannifin Corporation (the Company) cylinders or related accessories, it is important that you read, understand and follow the following safety information. Training is advised before selecting and using the Company's products.

1.0 General Instructions

1.1 Scope – This safety guide provides instructions for selecting and using (including assembling, installing, and maintaining) cylinder products. This safety guide is a supplement to and is to be used with the specific Company publications for the specific cylinder products that are being considered for use.

1.2 Fail Safe – Cylinder products can and do fail without warning for many reasons. All systems and equipment should be designed in a fail-safe mode so that if the failure of a cylinder product occurs people and property won't be endangered.

1.3 Distribution – Provide a free copy of this safety guide to each person responsible for selecting or using cylinder products. Do not select or use the Company's cylinders without thoroughly reading and understanding this safety guide as well as the specific Company publications for the products considered or selected.

1.4 User Responsibility – Due to very wide variety of cylinder applications and cylinder operating conditions, the Company does not warrant that any particular cylinder is suitable for any specific application. This safety guide does not analyze all technical parameters that must be considered in selecting a product. The hydraulic and pneumatic cylinders outlined in this catalog are designed to the Company's design guidelines and do not necessarily meet the design guideline of other agencies such as American Bureau of Shipping, ASME Pressure Vessel Code etc. The user, through its own analysis and testing, is solely responsible for:

- Making the final selection of the cylinders and related accessories.
- Determining if the cylinders are required to meet specific design requirements as required by the Agency(s) or industry standards covering the design of the user's equipment.
- Assuring that the user's requirements are met, OSHA requirements are met, and safety guidelines from the applicable agencies such as but not limited to ANSI are followed and that the use presents no health or safety hazards.
- Providing all appropriate health and safety warnings on the equipment on which the cylinders are used.

1.5 Additional Questions – Call the appropriate Company technical service department if you have any questions or require any additional information. See the Company publication for the product being considered or used, or call 1-847-298-2400, or go to www.parker.com, for telephone numbers of the appropriate technical service department.

2.0 Cylinder and Accessories Selection

2.1 Seals – Part of the process of selecting a cylinder is the selection of seal compounds. Before making this selection, consult the "seal information page(s)" of the publication for the series of cylinders of interest.

The application of cylinders may allow fluids such as cutting fluids, wash down fluids etc. to come in contact with the external area of the cylinder. These fluids may attack the piston rod wiper and or the primary seal and must be taken into account when selecting and specifying seal compounds.

Dynamic seals will wear. The rate of wear will depend on many operating factors. Wear can be rapid if a cylinder is mis-aligned or if the cylinder has been improperly serviced. The user must take seal wear into consideration in the application of cylinders.

2.2 Piston Rods – Possible consequences of piston rod failure or separation of the piston rod from the piston include, but are not limited to are:

- Piston rod and or attached load thrown off at high speed.
- High velocity fluid discharge.
- Piston rod extending when pressure is applied in the piston retract mode.

Piston rods or machine members attached to the piston rod may move suddenly and without warning as a consequence of other conditions occurring to the machine such as, but not limited to:

- Unexpected detachment of the machine member from the piston rod.

- Failure of the pressurized fluid delivery system (hoses, fittings, valves, pumps, compressors) which maintain cylinder position.
- Catastrophic cylinder seal failure leading to sudden loss of pressurized fluid.
- Failure of the machine control system.

Follow the recommendations of the "Piston Rod Selection Chart and Data" in the publication for the series of cylinders of interest. The suggested piston rod diameter in these charts must be followed in order to avoid piston rod buckling.

Piston rods are not normally designed to absorb bending moments or loads which are perpendicular to the axis of piston rod motion. These additional loads can cause the piston rod to fail. If these types of additional loads are expected to be imposed on the piston rod, their magnitude should be made known to our engineering department.

The cylinder user should always make sure that the piston rod is securely attached to the machine member.

On occasion cylinders are ordered with double rods (a piston rod extended from both ends of the cylinder). In some cases a stop is threaded on to one of the piston rods and used as an external stroke adjuster. On occasions spacers are attached to the machine member connected to the piston rod and also used as a stroke adjuster. In both cases the stops will create a pinch point and the user should consider appropriate use of guards. If these external stops are not perpendicular to the mating contact surface, or if debris is trapped between the contact surfaces, a bending moment will be placed on the piston rod, which can lead to piston rod failure. An external stop will also negate the effect of cushioning and will subject the piston rod to impact loading. Those two (2) conditions can cause piston rod failure. Internal stroke adjusters are available with and without cushions. The use of external stroke adjusters should be reviewed with our engineering department.

The piston rod to piston and the stud to piston rod threaded connections are secured with an anaerobic adhesive. The strength of the adhesive decreases with increasing temperature. Cylinders which can be exposed to temperatures above +250°F (+121°C) are to be ordered with a non studded piston rod and a pinned piston rod joint.

2.3 Cushions – Cushions should be considered for cylinder applications when the piston velocity is expected to be over 4 inches/second.

Cylinder cushions are normally designed to absorb the energy of a linear applied load. A rotating mass has considerably more energy than the same mass moving in a linear mode. Cushioning for a rotating mass application should be reviewed by our engineering department.

2.4 Cylinder Mountings – Some cylinder mounting configurations may have certain limitations such as but not limited to minimum stroke for side or foot mounting cylinders or pressure de-ratings for certain mounts. Carefully review the catalog for these types of restrictions.

Always mount cylinders using the largest possible high tensile alloy steel socket head cap screws that can fit in the cylinder mounting holes and torque them to the manufacturer's recommendations for their size.

2.5 Port Fittings – Hydraulic cylinders applied with meter out or deceleration circuits are subject to intensified pressure at piston rod end.

The rod end pressure is approximately equal to:

$$\frac{\text{operating pressure} \times \text{effective cap end area}}{\text{effective rod end piston area}}$$

Contact your connector supplier for the pressure rating of individual connectors.

3.0 Cylinder and Accessories Installation and Mounting

3.1 Installation

3.1.1 – Cleanliness is an important consideration, and cylinders are shipped with the ports plugged to protect them from contaminants entering the ports. These plugs should not be removed until the piping is to be installed. Before making the connection to the cylinder ports, piping should be thoroughly cleaned to remove all chips or burrs which might have resulted from threading or flaring operations.

3.1.2 – Cylinders operating in an environment where air drying materials are present such as fast-drying chemicals, paint, or weld splatter, or other hazardous conditions such as excessive heat, should have shields installed to prevent damage to the piston rod and piston rod seals.

3.1.3 – Proper alignment of the cylinder piston rod and its mating component on the machine should be checked in both the extended and retracted positions. Improper alignment will result in excessive rod gland and/or cylinder bore wear. On fixed mounting cylinders attaching the piston rod while the rod is retracted will help in achieving proper alignment.

3.1.4 – Sometimes it may be necessary to rotate the piston rod in order to thread the piston rod into the machine member. This operation must always be done with zero pressure being applied to either side of the piston. Failure to follow this procedure may result in loosening the piston to rod-threaded connection. In some rare cases the turning of the piston rod may rotate a threaded head and loosen it from the cylinder body. Confirm that this condition is not occurring. If it does, re-tighten the head firmly against the cylinder body.

For double rod cylinders it is also important that when attaching or detaching the piston rod from the machine member that the torque be applied to the piston rod end of the cylinder that is directly attaching to the machine member with the opposite end unrestrained. If the design of the machine is such that only the rod end of the cylinder opposite to where the rod attaches to the machine member can be rotated, consult the factory for further instructions.

3.2 Mounting Recommendations

3.2.1 – Always mount cylinders using the largest possible high tensile alloy steel socket head screws that can fit in the cylinder mounting holes and torque them to the manufacturer's recommendations for their size.

3.2.2 – Side-Mounted Cylinders – In addition to the mounting bolts, cylinders of this type should be equipped with thrust keys or dowel pins located so as to resist the major load.

3.2.3 – Tie Rod Mounting – Cylinders with tie rod mountings are recommended for applications where mounting space is limited. Nuts used for this mounting style should be torqued to the same value as the tie rods for that bore size.

3.2.4 – Flange Mount Cylinders – The controlled diameter of the rod gland extension on head end flange mount cylinders can be used as a pilot to locate the cylinders in relation to the machine. After alignment has been obtained, the flanges may be drilled for pins or dowels to prevent shifting.

3.2.5 – Trunnion Mountings – Cylinders require lubricated bearing blocks with minimum bearing clearances. Bearing blocks should be carefully aligned and rigidly mounted so the trunnions will not be subjected to bending moments. The rod end should also be pivoted with the pivot pin in line and parallel to axis of the trunnion pins.

3.2.6 – Clevis Mountings – Cylinders should be pivoted at both ends with centerline of pins parallel to each other. After cylinder is mounted, be sure to check to assure that the cylinder is free to swing through its working arc without interference from other machine parts.

4.0 Cylinder and Accessories Maintenance, Troubleshooting and Replacement

4.1 Storage – At times cylinders are delivered before a customer is ready to install them and must be stored for a period of time. When storage is required the following procedures are recommended.

4.1.1 – Store the cylinders in an indoor area which has a dry, clean and noncorrosive atmosphere. Take care to protect the cylinder from both internal corrosion and external damage.

4.1.2 – Whenever possible cylinders should be stored in a vertical position (piston rod up). This will minimize corrosion due to possible condensation which could occur inside the cylinder. This will also minimize seal damage.

4.1.3 – Port protector plugs should be left in the cylinder until the time of installation.

4.1.4 – If a cylinder is stored full of hydraulic fluid, expansion of the fluid due to temperature changes must be considered. Installing a check valve with free flow out of the cylinder is one method.

4.1.5 – When cylinders are mounted on equipment that is stored outside for extended periods, exposed unpainted surfaces, e.g. piston rod, must be coated with a rust-inhibiting compound to prevent corrosion.

4.2 Cylinder Trouble Shooting

4.2.1 – External Leakage

4.2.1.1 – Rod seal leakage can generally be traced to worn or damaged seals. Examine the piston rod for dents, gouges or score marks, and replace piston rod if surface is rough.

Rod seal leakage could also be traced to bearing wear. If clearance is excessive, replace rod bearing and seal. Rod seal leakage can also be traced to seal deterioration. If seals are soft or gummy or brittle, check compatibility of seal material with lubricant used if air cylinder, or operating fluid if hydraulic cylinder. Replace with seal material, which is compatible with these fluids. If the seals are hard or have lost elasticity, it is usually due to exposure to temperatures in excess of 165°F. (+74°C). Shield the cylinder from the heat source to limit temperature to 350°F. (+177°C.) and replace with fluorocarbon seals.

4.2.1.2 – Cylinder body seal leak can generally be traced to a loose head. Torque the head to manufacturer's recommendation for that bore size.

Excessive pressure can also result in cylinder body seal leak. Determine maximum pressure to rated limits. Replace seals and retorque head as in paragraph above. Excessive pressure can also result in cylinder body seal leak. Determine if the pressure rating of the cylinder has been exceeded. If so, bring the operating pressure down to the rating of the cylinder and have the head replaced.

Pinched or extruded cylinder body seal will also result in a leak. Replace cylinder body seal and retorque as in paragraph above.

Cylinder body seal leakage due to loss of radial squeeze which shows up in the form of flat spots or due to wear on the O.D. or I.D. – Either of these are symptoms of normal wear due to high cycle rate or length of service. Replace seals as per paragraph above.

4.2.2 – Internal Leakage

4.2.2.1 – Piston seal leak (by-pass) 1 to 3 cubic inches per minute leakage is considered normal for piston ring construction. Virtually no static leak with lipseal type seals on piston should be expected. Piston seal wear is a usual cause of piston seal leakage. Replace seals as required.

4.2.2.2 – With lipseal type piston seals excessive back pressure due to over-adjustment of speed control valves could be a direct cause of rapid seal wear. Contamination in a hydraulic system can result in a scored cylinder bore, resulting in rapid seal wear. In either case, replace piston seals as required.

4.2.2.3 – What appears to be piston seal leak, evidenced by the fact that the cylinder drifts, is not always traceable to the piston. To make sure, it is suggested that one side of the cylinder piston be pressurized and the fluid line at the opposite port be disconnected. Observe leakage. If none is evident, seek the cause of cylinder drift in other component parts in the circuit.

4.2.3 – Cylinder Fails to Move the Load

4.2.3.1 – Pneumatic or hydraulic pressure is too low. Check the pressure at the cylinder to make sure it is to circuit requirements.

4.2.3.2 – Piston Seal Leak – Operate the valve to cycle the cylinder and observe fluid flow at valve exhaust ports at end of cylinder stroke. Replace piston seals if flow is excessive.

4.2.3.3 – Cylinder is undersized for the load – Replace cylinder with one of a larger bore size.

4.3 Erratic or Chatter Operation

4.3.1 – Excessive friction at rod bearing or piston bearing due to load misalignment – Correct cylinder-to-load alignment.

4.3.2 – Cylinder sized too close to load requirements – Reduce load or install larger cylinder.

4.3.3 – Erratic operation could be traced to the difference between static and kinetic friction. Install speed control valves to provide a back pressure to control the stroke.

4.4 Cylinder Modifications, Repairs, or Failed Component

Cylinders as shipped from the factory are not to be disassembled or modified. If cylinders require modifications, these modifications must be done at company locations or by the Company's certified facilities. The Industrial Cylinder Division Engineering Department must be notified in the event of a mechanical fracture or permanent deformation of any cylinder component (excluding seals). This includes a broken piston rod, head, mounting accessory or any other cylinder component. The notification should include all operation and application details. This information will be used to provide an engineered repair that will prevent recurrence of the failure.

It is allowed to disassemble cylinders for the purpose of replacing seals or seal assemblies. However, this work must be done by strictly following all the instructions provided with the seal kits.

Offer of Sale

The items described in this document and other documents and descriptions provided by Parker Hannifin Corporation, its subsidiaries and its authorized distributors ("Seller") are hereby offered for sale at prices to be established by Seller. This offer and its acceptance by any customer ("Buyer") shall be governed by all of the following Terms and Conditions. Buyer's order for any item described in its document, when communicated to Seller verbally, or in writing, shall constitute acceptance of this offer. All goods, services or work described will be referred to as "Products".

1. Terms and Conditions. Seller's willingness to offer Products, or accept an order for Products, to or from Buyer is subject to these Terms and Conditions or any newer version of the terms and conditions found on-line at www.parker.com/saleterms/. Seller objects to any contrary or additional terms or conditions of Buyer's order or any other document issued by Buyer.

2. Price Adjustments; Payments. Prices stated on Seller's quote or other documentation offered by Seller are valid for 30 days, and do not include any sales, use, or other taxes unless specifically stated. Unless otherwise specified by Seller, all prices are F.C.A. Seller's facility (INCOTERMS 2010). Payment is subject to credit approval and is due 30 days from the date of invoice or such other term as required by Seller's Credit Department, after which Buyer shall pay interest on any unpaid invoices at the rate of 1.5% per month or the maximum allowable rate under applicable law.

3. Delivery Dates; Title and Risk; Shipment. All delivery dates are approximate and Seller shall not be responsible for any damages resulting from any delay. Regardless of the manner of shipment, title to any products and risk of loss or damage shall pass to Buyer upon placement of the products with the shipment carrier at Seller's facility. Unless otherwise stated, Seller may exercise its judgment in choosing the carrier and means of delivery. No deferral of shipment at Buyers' request beyond the respective dates indicated will be made except on terms that will indemnify, defend and hold Seller harmless against all loss and additional expense. Buyer shall be responsible for any additional shipping charges incurred by Seller due to Buyer's acts or omissions.

4. Warranty. Seller warrants that the Products sold hereunder shall be free from defects in material or workmanship for a period of eighteen months from the date of delivery to Buyer. The prices charged for Seller's products are based upon the exclusive limited warranty stated above, and upon the following disclaimer: **DISCLAIMER OF WARRANTY: THIS WARRANTY COMPRISES THE SOLE AND ENTIRE WARRANTY PERTAINING TO PRODUCTS PROVIDED HEREUNDER. SELLER DISCLAIMS ALL OTHER WARRANTIES, EXPRESS AND IMPLIED, INCLUDING DESIGN, MERCHANTABILITY AND FITNESS FOR A PARTICULAR PURPOSE.**

5. Claims; Commencement of Actions. Buyer shall promptly inspect all Products upon delivery. No claims for shortages will be allowed unless reported to the Seller within 10 days of delivery. No other claims against Seller will be allowed unless asserted in writing within 30 days after delivery. Buyer shall notify Seller of any alleged breach of warranty within 30 days after the date the defect is or should have been discovered by Buyer. Any action based upon breach of this agreement or upon any other claim arising out of this sale (other than an action by Seller for an amount due on any invoice) must be commenced within 12 months from the date of the breach without regard to the date breach is discovered.

6. LIMITATION OF LIABILITY. UPON NOTIFICATION, SELLER WILL, AT ITS OPTION, REPAIR OR REPLACE A DEFECTIVE PRODUCT, OR REFUND THE PURCHASE PRICE. **IN NO EVENT SHALL SELLER BE LIABLE TO BUYER FOR ANY SPECIAL, INDIRECT, INCIDENTAL OR CONSEQUENTIAL DAMAGES ARISING OUT OF, OR AS THE RESULT OF, THE SALE, DELIVERY, NON-DELIVERY, SERVICING, USE OR LOSS OF USE OF THE PRODUCTS OR ANY PART THEREOF, OR FOR ANY CHARGES OR EXPENSES OF ANY NATURE INCURRED WITHOUT SELLER'S WRITTEN CONSENT, EVEN IF SELLER HAS BEEN NEGLIGENT, WHETHER IN CONTRACT, TORT OR OTHER LEGAL THEORY. IN NO EVENT SHALL SELLER'S LIABILITY UNDER ANY CLAIM MADE BY BUYER EXCEED THE PURCHASE PRICE OF THE PRODUCTS.**

7. User Responsibility. The user, through its own analysis and testing, is solely responsible for making the final selection of the system and Product and assuring that all performance, endurance, maintenance, safety and warning requirements of the application are met. The user must analyze all aspects of the application and follow applicable industry standards and Product information. If Seller provides Product or system options, the user is responsible for determining that such data and specifications are suitable and sufficient for all applications and reasonably foreseeable uses of the Products or systems.

8. Loss to Buyer's Property. Any designs, tools, patterns, materials, drawings, confidential information or equipment furnished by Buyer or any other items which become Buyer's property, will be considered obsolete and may be destroyed by Seller after two consecutive years have elapsed without Buyer ordering the items manufactured using such property. Seller shall not be responsible for any loss or damage to such property while it is in Seller's possession or control.

9. Special Tooling. A tooling charge may be imposed for any special tooling, including without limitation, dies, fixtures, molds and patterns, acquired to manufacture Products. Such special tooling shall be and remain Seller's property notwithstanding payment of any charges by Buyer. In no event will Buyer acquire any interest in apparatus belonging to Seller which is utilized in the manufacture of the Products, even if such apparatus has been specially converted or adapted for such manufacture and notwithstanding any charges paid by Buyer. Unless otherwise agreed, Seller shall have the right to alter, discard or otherwise dispose of any special tooling or other property in its sole discretion at any time.

10. Buyer's Obligation; Rights of Seller. To secure payment of all sums due or otherwise, Seller shall retain a security interest in the goods delivered and this agreement shall be deemed a Security Agreement under the Uniform Commercial Code. Buyer authorizes Seller as its attorney to execute and file on Buyer's behalf all documents Seller deems necessary to perfect its security interest.

11. Improper use and Indemnity. Buyer shall indemnify, defend, and hold Seller harmless from any claim, liability, damages, lawsuits, and costs (including attorney fees), whether for personal injury, property damage, patent, trademark or copyright

infringement or any other claim, brought by or incurred by Buyer, Buyer's employees, or any other person, arising out of: (a) improper selection, improper application or other misuse of Products purchased by Buyer from Seller; (b) any act or omission, negligent or otherwise, of Buyer; (c) Seller's use of patterns, plans, drawings, or specifications furnished by Buyer to manufacture Product; or (d) Buyer's failure to comply with these terms and conditions. Seller shall not indemnify Buyer under any circumstance except as otherwise provided.

12. Cancellations and Changes. Orders shall not be subject to cancellation or change by Buyer for any reason, except with Seller's written consent and upon terms that will indemnify, defend and hold Seller harmless against all direct, incidental and consequential loss or damage. Seller may change product features, specifications, designs and availability with notice to Buyer.

13. Limitation on Assignment. Buyer may not assign its rights or obligations under this agreement without the prior written consent of Seller.

14. Force Majeure. Seller does not assume the risk and shall not be liable for delay or failure to perform any of Seller's obligations by reason of circumstances beyond the reasonable control of Seller (hereinafter "Events of Force Majeure"). Events of Force Majeure shall include without limitation: accidents, strikes or labor disputes, acts of any government or government agency, acts of nature, delays or failures in delivery from carriers or suppliers, shortages of materials, or any other cause beyond Seller's reasonable control.

15. Waiver and Severability. Failure to enforce any provision of this agreement will not waive that provision nor will any such failure prejudice Seller's right to enforce that provision in the future. Invalidation of any provision of this agreement by legislation or other rule of law shall not invalidate any other provision herein. The remaining provisions of this agreement will remain in full force and effect.

16. Termination. Seller may terminate this agreement for any reason and at any time by giving Buyer thirty (30) days written notice of termination. Seller may immediately terminate this agreement, in writing, if Buyer: (a) commits a breach of any provision of this agreement (b) appoints a trustee, receiver or custodian for all or any part of Buyer's property (c) files a petition for relief in bankruptcy on its own behalf, or by a third party (d) makes an assignment for the benefit of creditors, or (e) dissolves or liquidates all or a majority of its assets.

17. Governing Law. This agreement and the sale and delivery of all Products hereunder shall be deemed to have taken place in and shall be governed and construed in accordance with the laws of the State of Ohio, as applicable to contracts executed and wholly performed therein and without regard to conflicts of laws principles. Buyer irrevocably agrees and consents to the exclusive jurisdiction and venue of the courts of Cuyahoga County, Ohio with respect to any dispute, controversy or claim arising out of or relating to this agreement.

18. Indemnity for Infringement of Intellectual Property Rights. Seller shall have no liability for infringement of any patents, trademarks, copyrights, trade dress, trade secrets or similar rights except as provided in this Section. Seller will defend and indemnify Buyer against allegations of infringement of U.S. patents, U.S. trademarks, copyrights, trade dress and trade secrets ("Intellectual Property Rights"). Seller will defend at its expense and will pay the cost of any settlement or damages awarded in an action brought against Buyer based on an allegation that a Product sold pursuant to this Agreement infringes the Intellectual Property Rights of a third party. Seller's obligation to defend and indemnify Buyer is contingent on Buyer notifying Seller within ten (10) days after Buyer becomes aware of such allegations of infringement, and Seller having sole control over the defense of any allegations or actions including all negotiations for settlement or compromise. If a Product is subject to a claim that it infringes the Intellectual Property Rights of a third party, Seller may, at its sole expense and option, procure for Buyer the right to continue using the Product, replace or modify the Product so as to make it noninfringing, or offer to accept return of the Product and return the purchase price less a reasonable allowance for depreciation. Notwithstanding the foregoing, Seller shall have no liability for claims of infringement based on information provided by Buyer, or directed to Products delivered hereunder for which the designs are specified in whole or part by Buyer, or infringements resulting from the modification, combination or use in a system of any Product sold hereunder. The foregoing provisions of this Section shall constitute Seller's sole and exclusive liability and Buyer's sole and exclusive remedy for infringement of Intellectual Property Rights.

19. Entire Agreement. This agreement contains the entire agreement between the Buyer and Seller and constitutes the final, complete and exclusive expression of the terms of sale. All prior or contemporaneous written or oral agreements or negotiations with respect to the subject matter are herein merged.

20. Compliance with Law, U. K. Bribery Act and U.S. Foreign Corrupt Practices Act. Buyer agrees to comply with all applicable laws and regulations, including both those of the United Kingdom and the United States of America, and of the country or countries of the Territory in which Buyer may operate, including without limitation the U. K. Bribery Act, the U.S. Foreign Corrupt Practices Act ("FCPA") and the U.S. Anti-Kickback Act (the "Anti-Kickback Act"), and agrees to indemnify and hold harmless Seller from the consequences of any violation of such provisions by Buyer, its employees or agents. Buyer acknowledges that they are familiar with the provisions of the U. K. Bribery Act, the FCPA and the Anti-Kickback Act, and certifies that Buyer will adhere to the requirements thereof. In particular, Buyer represents and agrees that Buyer shall not make any payment or give anything of value, directly or indirectly to any governmental official, any foreign political party or official thereof, any candidate for foreign political office, or any commercial entity or person, for the purpose of influencing such person to purchase products or otherwise benefit the business of Seller.



Parker Hannifin Corporation
Atlas Cylinders
500 South Wolf Road
Des Plaines, IL 60016 USA
phone (847) 298-2400
fax (800) 892-1008
www.atlascylinders.com