

Series L Medium Duty Industrial Hydraulic Cylinders

Catalog HY04-AC1130-3/US
November, 2014



ATLAS CYLINDERS

Medium-Duty Hydraulic Cylinders Atlas Series L

A Series Cylinders Up to 250 PSI



Series A air cylinders are available in bore sizes from 1½" through 14" and up to 250 PSI operating pressure.

H Series Cylinders Operating Pressure to 3000 PSI



Atlas' heavy duty cylinder line for demanding hydraulic applications. Bore sizes from 1½" to 8".

ESP Series Cylinders Operating Pressure to 3000 PSI



Electronic Stroke Positioning heavy duty cylinders with resolution to .0005", operating pressure to 3000 PSI.

Custom Cylinders



Bores to 42" and Strokes to 900". Full range of offering from micro cylinders to cylinders over 40,000 lbs.

In line with our policy of continuing product improvement, specifications and information contained in this catalog are subject to change.

Copyright ©2008, 2011, 2014 by Parker Hannifin Corporation.
All rights reserved.

PRINTED IN THE U.S.A.

WARNING

FAILURE OR IMPROPER SELECTION OR IMPROPER USE OF THE PRODUCTS AND/OR SYSTEMS DESCRIBED HEREIN OR RELATED ITEMS CAN CAUSE DEATH, PERSONAL INJURY AND PROPERTY DAMAGE.

This document and other information from the Parker Hannifin Corporation, its subsidiaries and authorized distributors provide product and/or system options for further investigation by users having expertise. It is important that you analyze all aspects of your application, including consequences of any failure and review the information concerning the product or system in the current product catalog. Due to the variety of operating conditions and applications for these products or systems, the user, through its own analysis and testing, is solely responsible for making the final selection of the products and systems and assuring that all performance, safety and warning requirements of the application are met.

The products described herein, including without limitation, product features, specifications, designs, availability and pricing, are subject to change by Parker Hannifin Corporation and its subsidiaries at any time without notice.

Offer of Sale

The items described in this document are hereby offered for sale by Parker Hannifin Corporation, its subsidiaries or its authorized distributors. This offer and its acceptance are governed by provisions stated on a separate page of the document entitled 'Offer of Sale'.

Table of Contents	Page
Specifications, Mounting Styles	3
Cylinder Features	4, 5
	Bore Sizes
	1 1/2" to 6" 8"
Style SL, Side Lug Mount (NFPA MS2)	6, 728, 29
Style FS, Side Tap Mount (NFPA MS4)	8, 928, 29
Style REF2, Head Rectangular Flange Mount (NFPA MF1)	10, 11N/A
Style BEF2, Cap Rectangular Flange Mount (NFPA MF2)	12, 13N/A
Style REF1, Head Square Flange Mount (NFPA MF5)	14, 15N/A
Style BEF1, Cap Square Flange Mount (NFPA MF6)	14, 15N/A
Style REF, Head Square Mount (NFPA MF5).....	N/A26, 27
Style BEF, Cap Square Mount (NFPA MF6).....	N/A26, 27
Styles NM1, NM2, NM3 Tie Rods Extended Mounts (Both Ends NFPA MX1, Cap End NFPA MX2, Head End NFPA MX3)	16, 1726, 27
Style TM1, Head Trunnion Mount (NFPA MT1)	18, 1930, 31
Style TM2, Cap Trunnion Mount (NFPA MT2)	20, 2130, 31
Style TM3, Intermediate Trunnion Mount (NFPA MT4)	22, 2330, 31
Style PB2, Cap Fixed Clevis Mount (NFPA MP1).....	24, 2528, 29
Style SA, Spherical Bearing Mount (NFPA MPU3).....	3232
Spherical Bearing Mount.....	32
Spherical Bearing Mount Accessories	33
Double Rod End Cylinders	34
Cylinder Accessories.....	36-39
“Style 5” Piston Rod End, Split Couplers & Weld Plates.....	40, 41
Linear Alignment Couplers	42
Push and Pull Forces	43
Operating Fluids and Temperature Range	44
Cylinder Pressure Ratings, Oversize Ports.....	45
Ports.....	46
Stroke Data, Tie Rod Supports.....	47
Cylinder Weights	48
Stop Tube, Mounting Classes	49
Piston Rod Selection Chart and Data	50
Parts List and Seal Kits	51-54
End-of-Stroke Magnetic Principle Type Proximity Switch	55
How to Order an Atlas Cylinder	56, 57
Cylinders for Wood Products Applications.....	57
Cylinder Safety Guide	58-59
Offer of Sale.....	IBC

Atlas Series L Medium-Duty Hydraulic Cylinder

When the job calls for reliable performance, specify Series L. A 100,000 psi yield strength chrome-plated, case-hardened piston rod. A 125,000 psi yield strength rod-end stud with rolled threads. 100,000 psi yield strength tie rods. With construction like this, Atlas Series L cylinders are truly premium quality.

And to make sure every cylinder is premium quality, we subject each and every one – not just batch samples – to tough inspection and performance tests. See the following pages for the inside story on all the features that make Series L the high performance, long lasting choice for all your medium-duty hydraulic applications.



Standard Specifications

- Medium Duty Service – ANSI/(NFPA) T3.6.7R2-1996 Specifications and Mounting Dimension Standards
- Standard Construction – Square Head – Tie Rod Design
- Nominal Pressure – 1,000 PSI Depending on Bore Size
- Standard Fluid – Hydraulic Oil
- Standard Temperature – -10°F. to +165°F.
- Bore Sizes – 1½" through 8"
- Piston Rod Diameters – 5/8" through 2½"
- Mounting Styles – 14 standard styles at various application ratings
- Strokes – Available in any practical stroke length
- Cushions – Optional at either end or both ends of stroke. "Float Check" at cap end.
- Rod Ends – Four Standard Choices – Specials to Order

In line with our policy of continuing product improvement, specifications in this catalog are subject to change.

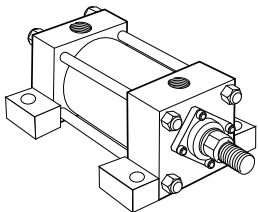
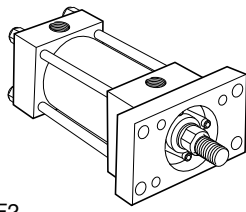
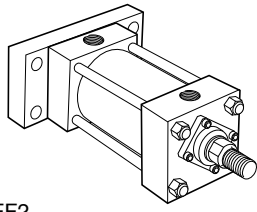
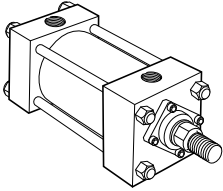
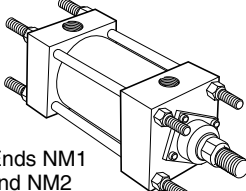
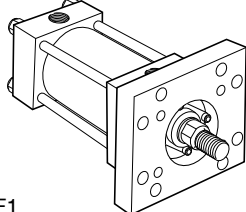
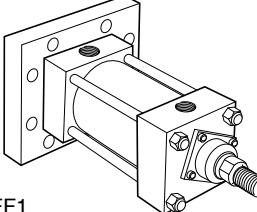
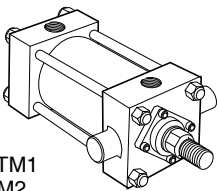
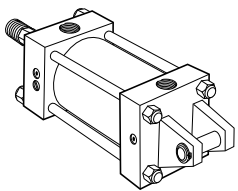
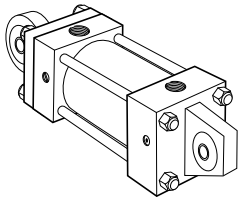
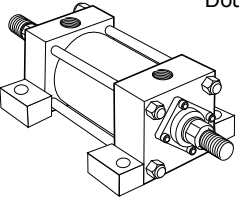
Mounting Styles and Ordering Notes																																																																																																																														
Available in all bore and rod combinations.			Available in bore and rod combinations through 6" bore. 8" bore supplied as Head Square (REF) and Cap Square (BEF) mounts.																																																																																																																											
<p>Side Lug</p>  <p>SL</p>			<p>Head Rectangular Flange</p>  <p>REF2</p>		<p>Cap Rectangular Flange</p>  <p>BEF2</p>																																																																																																																									
<p>Side Tap</p>  <p>FS</p>		<p>Tie Rods Extended Both Ends</p>  <p>Both Ends NM1 Cap End NM2 Head End NM3</p>		<p>Head Square Flange</p>  <p>REF1</p>		<p>Cap Square Flange</p>  <p>BEF1</p>																																																																																																																								
<p>Trunnion Mounts</p>  <p>Head TM1 Cap TM2 Intermediate Fixed TM3</p>		<p>Cap Fixed Clevis</p>  <p>PB2 Pivot Pin Included</p>		<p>Rod Gland Construction</p> <p>B = Bolted Gland R = Retainer Held Gland</p> <table border="1"> <thead> <tr> <th rowspan="2">Bore</th> <th rowspan="2">Rod Dia.</th> <th colspan="2">NM2 FS</th> <th rowspan="2">NM1</th> <th rowspan="2">REF1</th> <th rowspan="2">REF BEF</th> </tr> <tr> <th>SL</th> <th>BEF1</th> </tr> <tr> <th colspan="2"></th> <th>TM1</th> <th>TM3</th> <th>NM3</th> <th>REF2</th> <th>BEF</th> </tr> </thead> <tbody> <tr> <td rowspan="2">1½</td> <td>5/8</td> <td>B</td> <td></td> <td>R</td> <td>R</td> <td>N/A</td> </tr> <tr> <td>1</td> <td>R</td> <td></td> <td>R</td> <td>R</td> <td>N/A</td> </tr> <tr> <td rowspan="3">2</td> <td>5/8</td> <td>B</td> <td></td> <td>R</td> <td>B</td> <td>N/A</td> </tr> <tr> <td>1</td> <td>B</td> <td></td> <td>R</td> <td>R</td> <td>N/A</td> </tr> <tr> <td>1 3/8</td> <td>R</td> <td></td> <td>R</td> <td>R</td> <td>N/A</td> </tr> <tr> <td rowspan="3">2½</td> <td>5/8</td> <td>B</td> <td></td> <td>R</td> <td>B</td> <td>N/A</td> </tr> <tr> <td>1</td> <td>B</td> <td></td> <td>R</td> <td>B</td> <td>N/A</td> </tr> <tr> <td>1 3/8</td> <td>R</td> <td></td> <td>R</td> <td>R</td> <td>N/A</td> </tr> <tr> <td rowspan="3">3¼</td> <td>1</td> <td>B</td> <td></td> <td>B</td> <td>B</td> <td>N/A</td> </tr> <tr> <td>1 3/8</td> <td>B</td> <td></td> <td>B</td> <td>B</td> <td>N/A</td> </tr> <tr> <td>1 3/4, 2</td> <td>B</td> <td></td> <td>R</td> <td>R</td> <td>N/A</td> </tr> <tr> <td rowspan="2">4</td> <td>1, 1 3/8</td> <td>B</td> <td></td> <td>B</td> <td>B</td> <td>N/A</td> </tr> <tr> <td>1 3/4, 2</td> <td>B</td> <td></td> <td>B</td> <td>B</td> <td>N/A</td> </tr> <tr> <td>5</td> <td>1 - 2</td> <td>B</td> <td></td> <td>B</td> <td>B</td> <td>N/A</td> </tr> <tr> <td>6</td> <td>1 3/8 - 2 1/2</td> <td>B</td> <td></td> <td>B</td> <td>B</td> <td>N/A</td> </tr> <tr> <td>8*</td> <td>1 3/8 - 2 1/2</td> <td>B</td> <td></td> <td>B</td> <td>N/A</td> <td>B</td> </tr> </tbody> </table>			Bore	Rod Dia.	NM2 FS		NM1	REF1	REF BEF	SL	BEF1			TM1	TM3	NM3	REF2	BEF	1½	5/8	B		R	R	N/A	1	R		R	R	N/A	2	5/8	B		R	B	N/A	1	B		R	R	N/A	1 3/8	R		R	R	N/A	2½	5/8	B		R	B	N/A	1	B		R	B	N/A	1 3/8	R		R	R	N/A	3¼	1	B		B	B	N/A	1 3/8	B		B	B	N/A	1 3/4, 2	B		R	R	N/A	4	1, 1 3/8	B		B	B	N/A	1 3/4, 2	B		B	B	N/A	5	1 - 2	B		B	B	N/A	6	1 3/8 - 2 1/2	B		B	B	N/A	8*	1 3/8 - 2 1/2	B		B	N/A	B
Bore	Rod Dia.	NM2 FS							NM1	REF1				REF BEF																																																																																																																
		SL	BEF1																																																																																																																											
		TM1	TM3				NM3	REF2	BEF																																																																																																																					
1½	5/8	B					R	R	N/A																																																																																																																					
	1	R		R	R	N/A																																																																																																																								
2	5/8	B		R	B	N/A																																																																																																																								
	1	B		R	R	N/A																																																																																																																								
	1 3/8	R		R	R	N/A																																																																																																																								
2½	5/8	B		R	B	N/A																																																																																																																								
	1	B		R	B	N/A																																																																																																																								
	1 3/8	R		R	R	N/A																																																																																																																								
3¼	1	B		B	B	N/A																																																																																																																								
	1 3/8	B		B	B	N/A																																																																																																																								
	1 3/4, 2	B		R	R	N/A																																																																																																																								
4	1, 1 3/8	B		B	B	N/A																																																																																																																								
	1 3/4, 2	B		B	B	N/A																																																																																																																								
5	1 - 2	B		B	B	N/A																																																																																																																								
6	1 3/8 - 2 1/2	B		B	B	N/A																																																																																																																								
8*	1 3/8 - 2 1/2	B		B	N/A	B																																																																																																																								
<p>Cap Fixed Eye with Spherical Bearing</p>  <p>SA</p>																																																																																																																														
<p>Double End Construction</p>  <p>Available in all bore and rod combinations in the following mounting styles: XSL, XFS, XNM1, XNM3, XTM1, XTM3, and XREF2 (1½"-6"). XREF1 (1½"-6") and XREF (8").</p>																																																																																																																														

*REF1, REF2, BEF1, BEF2 not available in this bore size.

The inside story on why Series L is your best choice in medium-duty hydraulic cylinders.

Primary Seal – “Tuffseal” Special polyurethane seal is a proven leakproof design, which incorporates the pressure-compensated uni-directional characteristics of a “U CUP” with the multiple edge sealing effectiveness of compression-type stacked-packings.

Secondary Seal – A Double-Service Wiperseal™ acts as a secondary pressure seal on the extend stroke and cleans the rod on the return stroke.

Bolt-On Rod Cartridge – Assures true concentricity and allows removal without tie rod disassembly.

Piston Rod Stud – Furnished on 2" diameter rods and smaller when standard style 1 rod end threads are required. Piston rod studs are also available in 2 times the catalog “A” dimension length. Studs have rolled threads and are made from high strength steel. Anaerobic adhesive is used to permanently lock the stud to the piston rod.

Long Bearing Surface – is inboard of the seals, assuring positive lubrication from within the cylinder. An “O” ring is used as a seal between gland and head, and also serves as a prevailing torque-type lock.

Piston Rod – Medium carbon steel, induction case-hardened to 54 Rc, hard chrome-plated and polished to 10 RMS finish. Piston rods are made from 90,000 to 100,000 psi minimum yield material in 5/8" through 2 1/2" diameters. Larger diameters vary between 57,000 and 90,000 psi minimum yield material, depending on rod diameter. The piston thread equals the catalog style #1 rod end thread for each rod diameter to assure proper piston-to-rod thread strength. Two wrench flats are provided for rod end attachment.

Steel Head – Bored and grooved to provide concentricity for mating parts.

Ports – NPTF ports are standard. SAE ports available.

End Seals – Pressure-actuated cylinder body-to-head and cap O rings.

Alloy Steel Tie Rod Nuts

Align-A-Groove – A 3/16" wide surface machined at each end of the cylinder body. This makes precise mounting quick and easy.

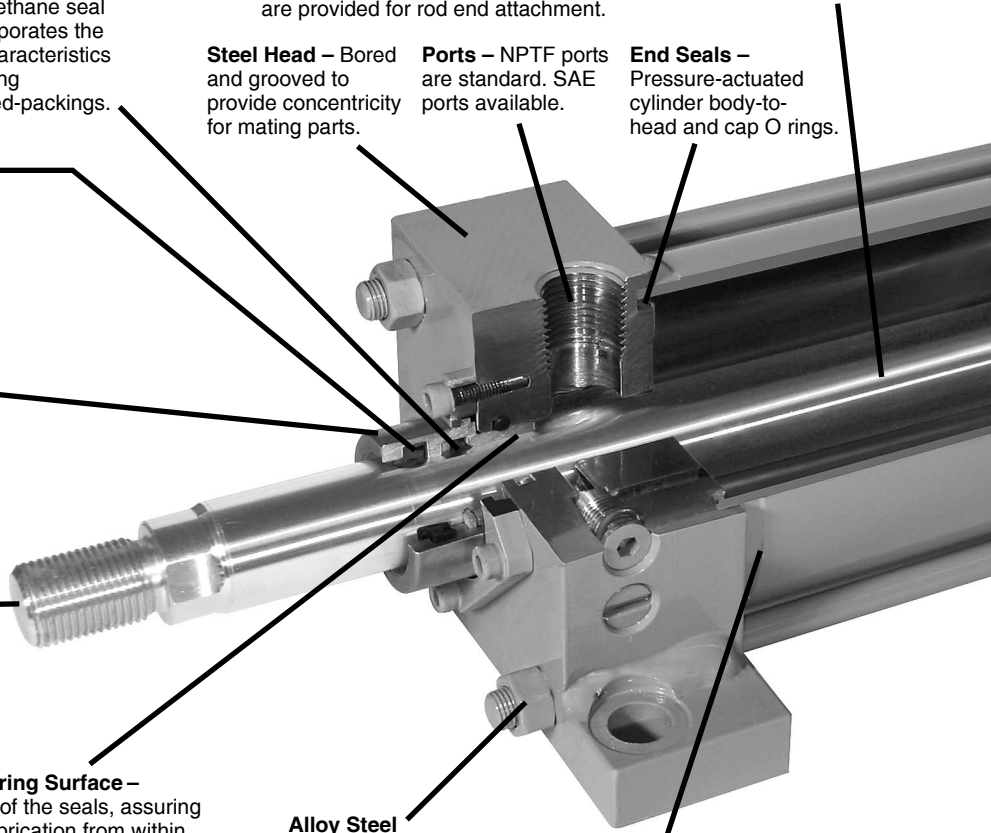

Adjustable floating cushions

Cushions are optional, and can be supplied at head end, cap end, or both ends without change in envelope or mounting dimensions. Cushions are adjustable.

The Series L cylinder design incorporates the longest cushion sleeve and cushion spear that can be provided in the standard envelope without decreasing the rod bearing and piston bearing lengths.

- (1) When a cushion is specified at the head end:
 - a. A self-centering sleeve is supplied on the piston rod assembly.
 - b. A needle valve is provided that is flush with the side of the head when wide open. It may be identified by the fact that it is socket-keyed. Needle valves are located on side number 2 in all mounting styles except TM1, TM2 and TM3. These styles have needle valves located on side number 3.
 - c. On 3 1/4" bores and larger, a springless check valve is provided that is also flush with the side of the head and is mounted on the face adjacent to the

needle valve except on certain bores of mounting style SL where it is mounted opposite the needle valve. It may be identified by the fact that it is slotted.

- d. The check and needle valves are interchangeable in the head.
- e. 1 1/2" - 2 1/2" bore Series L utilize a slotted sleeve design in place of the check valve.
- (2) When a cushion is specified at the cap end:
 - a. A cushion spear is provided on the piston rod assembly.
 - b. A “Float Check” self-centering bushing is provided which incorporates a large flow check valve for fast “out-stroke” action.
 - c. A socket-keyed needle valve is provided that is flush with the side of the cap when wide open. It is located on side number 2 in all mounting styles except TM1, TM2 and TM3. These styles have needle valves located on side number 3.

Adjustable Floating Cushions – Cushions are optional and can be supplied at head end, cap end, or both ends without change in envelope or mounting dimensions.

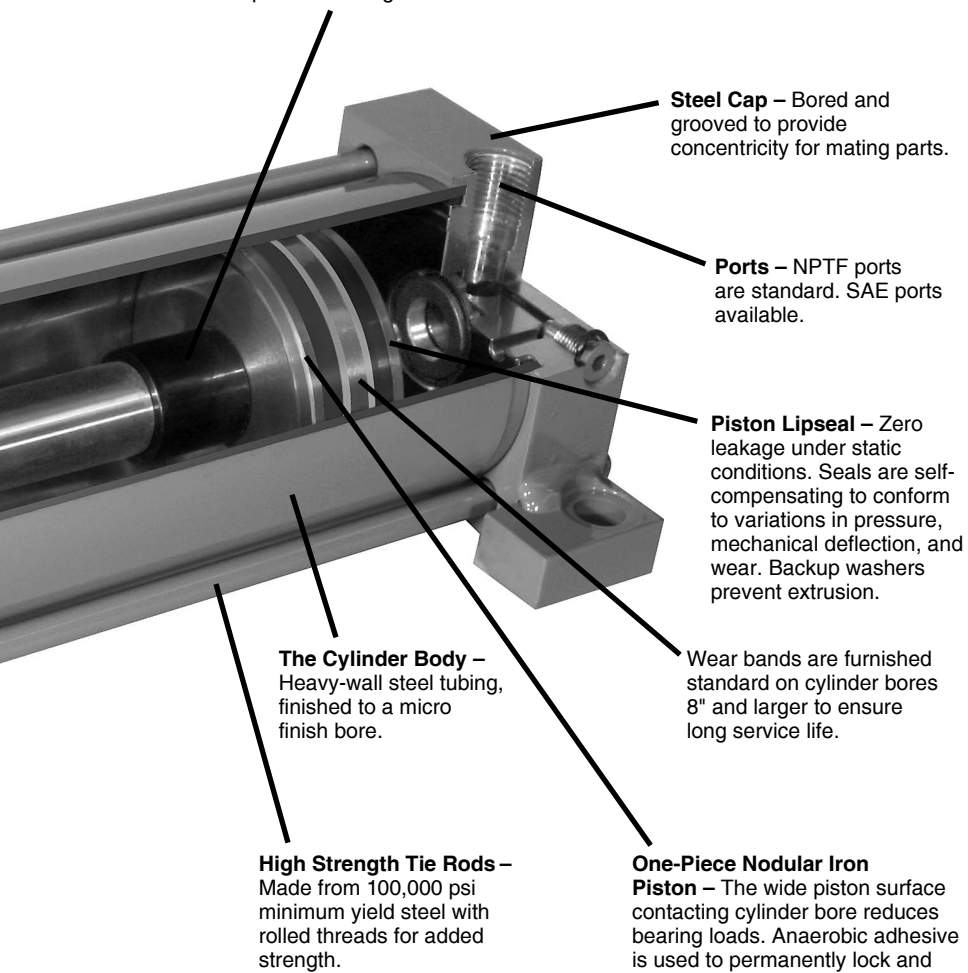

Sleeve Design

Spear Design

Optional Adjustable Floating Stepped Cushions

Adjustable Floating Stepped Cushions – Optional at extra charge. For faster cycle time and increased productivity – for maximum performance – economical and flexible for even the most demanding applications – reduces shock and machine noise – lower maintenance costs – can be supplied at head, cap or both ends.

Cushion Length

Cylinder Bore (Inches)	Rod Diameter* (Inches)	Cushion Length (Inches)	
		Head*	Cap
1 1/2	5/8	7/8	13/16
	1	7/8	13/16
2	5/8	7/8	13/16
	1 3/8	7/8	13/16
2 1/2	1	7/8	13/16
	1 3/4	7/8	13/16
3 1/4	1	1 1/8	1
	2	13/16	1
4	1	1 1/8	1
	2	13/16	1

Cylinder Bore (Inches)	Rod Diameter* (Inches)	Cushion Length (Inches)	
		Head*	Cap
5	1	1 1/8	1
	2	13/16	1
6	1 3/8	1 3/8	1 1/4
	2 1/2	13/16	1 1/4
8	1 3/8	1 1/16	1 1/4
	2 1/2	13/16	1 1/4

*Head end cushions for rod diameters not listed have cushion lengths with the limits shown.

**Side Lug Mount
Style SL**

1 1/2" - 2" and 2 1/2" Bore
With Maximum Oversize Rods

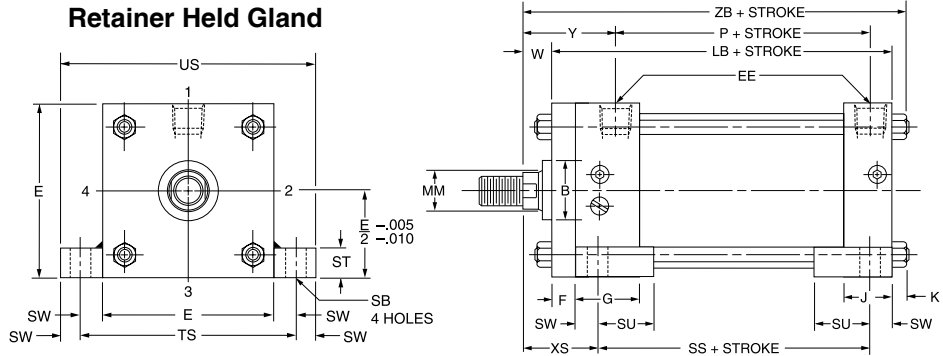
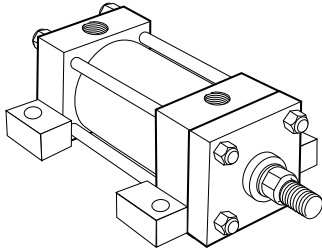

Before determining dimensions: See chart on page 3 for cylinder rod combinations that have a bolted gland.

**Side Lug Mount
Style SL**

1 1/2" - 6" Bore

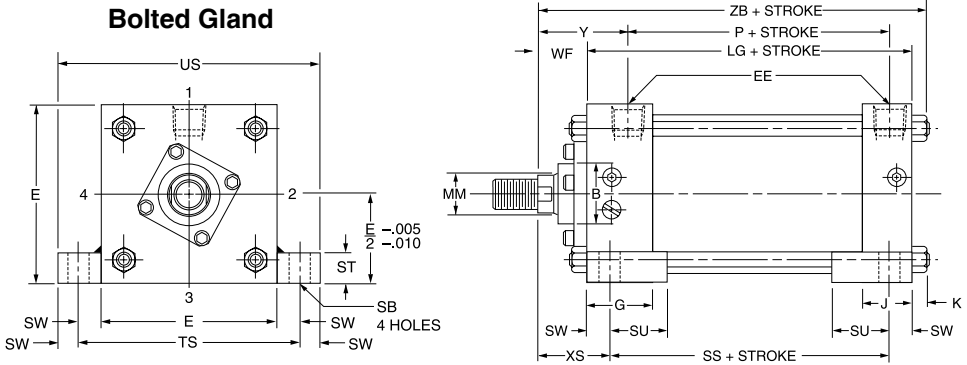
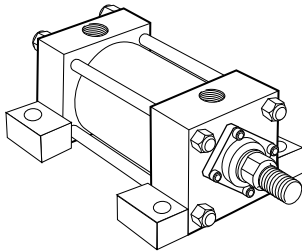

Rod End Dimensions (for Retainer Held Gland) — See Table 2

See chart on page 3 to determine which bore, rod, and mount combinations have this feature.

Thread Style 1
Small Male

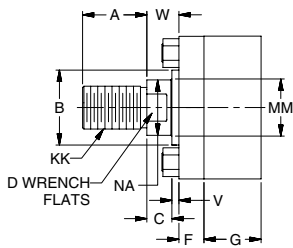

Thread Style 2
Intermediate Male

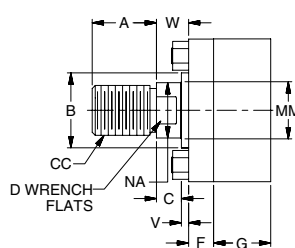

Thread Style 3
Short Female

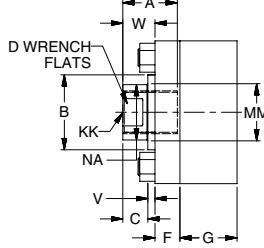

Style 6
Stub End

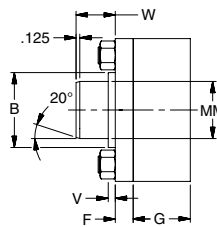

"Special" Thread Style 4

Special thread, extension, rod eye, blank, etc., are also available.

To order, specify "Style 4" and give desired dimensions for KK, A, W or WF. If otherwise special, furnish dimensioned sketch.

A high strength rod end stud is supplied on thread style 1 through 2" diameter rods. Larger sizes or special rod ends are cut threads. Style 1 rod ends are recommended where the workpiece is secured against the rod shoulder. When the workpiece is not shouldered,

style 1 rod ends are recommended through 2" piston rod diameters and style 2 rod ends are recommended on larger diameters. Use style 3 for applications where female rod end threads are required. If rod end is not specified, style 1 will be supplied.

Table 1—Envelope and Mounting Dimensions

Bore	E	EE		F	G	J	K	SB*	ST	SU	SW	TS	US	Add Stroke			
		NPTF [†]	SAE*											LB	LG	P	SS
1½	2	¾†	6‡	¾	1½	1	¼	7/16	½	15/16	¾	2¾	3½	4	35/8	2¼	27/8
2	2½	¾†	6	¾	1½	1	5/16	7/16	½	15/16	¾	3¾	4	4	35/8	2¼	27/8
2½	3	¾†	6	¾	1½	1	5/16	7/16	½	15/16	¾	3¾	4½	4½	3¾	2¾	3
3¼	3¾	½	8	—	1¾	1¼	¾	9/16	¾	1¼	½	4¾	5¾	47/8	4¼	25/8	3¼
4	4½	½	8	—	1¾	1¼	¾	9/16	¾	1¼	½	5½	6½	47/8	4¼	25/8	3¼
5	5½	½	8	5/8	1¾	1¼	7/16	13/16	1	19/16	11/16	67/8	8¼	5½	4½	27/8	3½
6	6½	¾	12	¾	2	1½	7/16	13/16	1	19/16	11/16	77/8	9¼	5¾	5	3½	35/8

† On 1½", 2" and 2½" bore sizes, the head-end (only) pipe thread is not full depth on cylinders with maximum oversize rods. Minimum of three full threads available. ‡ NPTF ports will be furnished as standard unless SAE straight thread ports are specified.

• Upper surface spot-faced for socket head screws. *SAE straight thread ports are indicated by port number.

‡ Straight thread ports. On 1½" bore size an adapter fitting is required on cap end and on head end with maximum oversize rod. (See "Straight Thread Port Adapter" drawing.) Adapters are furnished as standard.

Straight Thread Port Adapters

Used on 1 1/2" bore size only.

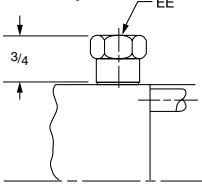

Table 2—Rod Dimensions

Bore	Rod Dia. MM	Thread		Rod Extensions and Pilot Dimensions										Add Stroke		
		Style 2 CC	Style 1 & 3 KK	A	+0.000 -0.002 B	C	D	NA	V	VA	VB	W	WF	XS	Y	ZB
1½	5/8	½-20	7/16-20	¾	1.124	¾	½	9/16	—	¼	3/16	—	1	1¾	115/16	47/8
	1	7/8-14	¾-16	1½	1.499	½	7/8	15/16	½	—	—	1	—	1¾	25/16	5¼
2	5/8	½-20	7/16-20	¾	1.124	¾	½	9/16	—	¼	3/16	—	1	1¾	115/16	415/16
	1	7/8-14	¾-16	1½	1.499	½	7/8	15/16	—	¼	3/8	—	1¾	1¾	25/16	55/16
2½	1¾	1¼-12	1-14	15/8	1.999	5/8	1½	15/16	5/8	—	—	1¼	—	2	29/16	59/16
	5/8	½-20	7/16-20	¾	1.124	¾	½	9/16	—	¼	3/16	—	1	1¾	115/16	51/16
	1	7/8-14	¾-16	1½	1.499	½	7/8	15/16	—	¼	3/8	—	1¾	1¾	25/16	57/16
3¼	1¾	1¼-12	1-14	15/8	1.999	5/8	1½	15/16	5/8	—	—	1¼	—	2	29/16	511/16
	1¾	1¼-12	1¼-12	2	2.374	¾	1½	111/16	¾	—	—	1½	—	2¼	213/16	515/16
	1	7/8-14	¾-16	1½	1.499	½	7/8	15/16	—	¼	3/8	—	1¾	17/8	27/16	6
4	1¾	1¼-12	1-14	15/8	1.999	5/8	1½	15/16	—	¼	½	—	15/8	21/8	211/16	6¼
	1¾	1¼-12	1¼-12	2	2.374	¾	1½	111/16	—	¼	9/16	—	17/8	23/8	215/16	6½
	2	1¾-12	1½-12	2¼	2.624	7/8	111/16	115/16	—	¼	9/16	—	2	2½	31/16	65/8
5	1	7/8-14	¾-16	1½	1.499	½	7/8	15/16	—	¼	3/8	—	1¾	17/8	27/16	6
	1¾	1¼-12	1-14	15/8	1.999	5/8	1½	15/16	—	¼	½	—	15/8	21/8	211/16	6¼
	1¾	1¼-12	1¼-12	2	2.374	¾	1½	111/16	—	¼	9/16	—	17/8	23/8	215/16	6½
6	1	7/8-14	¾-16	1½	1.499	½	7/8	15/16	—	¼	3/8	—	1¾	17/8	27/16	6
	1¾	1¼-12	1-14	15/8	1.999	5/8	1½	15/16	—	¼	½	—	15/8	21/8	211/16	6¼
	1¾	1¼-12	1¼-12	2	2.374	¾	1½	111/16	—	¼	9/16	—	17/8	23/8	215/16	6½
6	1	7/8-14	¾-16	1½	1.499	½	7/8	15/16	—	¼	3/8	—	1¾	17/8	27/16	6
	1¾	1¼-12	1-14	15/8	1.999	5/8	1½	15/16	—	¼	½	—	15/8	21/8	211/16	6¼
	1¾	1¼-12	1¼-12	2	2.374	¾	1½	111/16	—	¼	9/16	—	17/8	23/8	215/16	6½
6	1	7/8-14	¾-16	1½	1.499	½	7/8	15/16	—	¼	3/8	—	1¾	17/8	27/16	6
	1¾	1¼-12	1-14	15/8	1.999	5/8	1½	15/16	—	¼	½	—	15/8	21/8	211/16	6¼
	1¾	1¼-12	1¼-12	2	2.374	¾	1½	111/16	—	¼	9/16	—	17/8	23/8	215/16	6½
6	1	7/8-14	¾-16	1½	1.499	½	7/8	15/16	—	¼	3/8	—	1¾	17/8	27/16	6
	1¾	1¼-12	1-14	15/8	1.999	5/8	1½	15/16	—	¼	½	—	15/8	21/8	211/16	6¼
	1¾	1¼-12	1¼-12	2	2.374	¾	1½	111/16	—	¼	9/16	—	17/8	23/8	215/16	6½
6	1	7/8-14	¾-16	1½	1.499	½	7/8	15/16	—	¼	3/8	—	1¾	17/8	27/16	6
	1¾	1¼-12	1-14	15/8	1.999	5/8	1½	15/16	—	¼	½	—	15/8	21/8	211/16	6¼
	1¾	1¼-12	1¼-12	2	2.374	¾	1½	111/16	—	¼	9/16	—	17/8	23/8	215/16	6½
6	1	7/8-14	¾-16	1½	1.499	½	7/8	15/16	—	¼	3/8	—	1¾	17/8	27/16	6
	1¾	1¼-12	1-14	15/8	1.999	5/8	1½	15/16	—	¼	½	—	15/8	21/8	211/16	6¼
	1¾	1¼-12	1¼-12	2	2.374	¾	1½	111/16	—	¼	9/16	—	17/8	23/8	215/16	6½
6	1	7/8-14	¾-16	1½	1.499	½	7/8	15/16	—	¼	3/8	—	1¾	17/8	27/16	6
	1¾	1¼-12	1-14	15/8	1.999	5/8	1½	15/16	—	¼	½	—	15/8	21/8	211/16	6¼
	1¾	1¼-12	1¼-12	2	2.374	¾	1½	111/16	—	¼	9/16	—	17/8	23/8	215/16	6½

Rod End Dimensions (for Bolted Gland) — See Table 2

See chart on page 3 to determine which bore, rod, and mount combinations have this feature.

Thread Style 1
Small Male

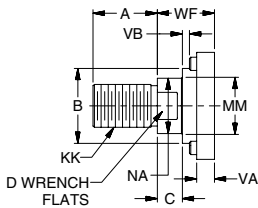

Thread Style 2
Intermediate Male

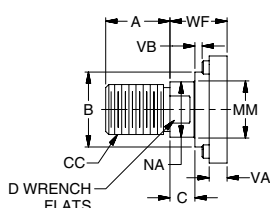

Thread Style 3
Short Female

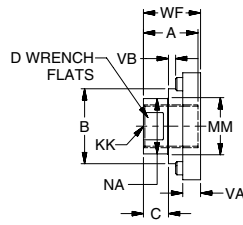

Style 6
Stub End

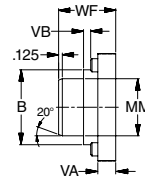

“Special” Thread Style 4

Special thread, extension, rod eye, blank, etc., are also available. To order, specify “Style 4” and give desired dimensions for KK, A, W or WF. If otherwise special, furnish dimensioned sketch.

A high strength rod end stud is supplied on thread style 1 through 2" diameter rods. Larger sizes or special rod ends are cut threads. Style 1 rod ends are recommended where the workpiece is secured against the rod shoulder. When the workpiece is not shouldered,

style 1 rod ends are recommended through 2" piston rod diameters and style 2 rod ends are recommended on larger diameters. Use style 3 for applications where female rod end threads are required. If rod end is not specified, style 1 will be supplied.

**Side Tap Mount
Style FS**

1 1/2" - 2" and 2 1/2" Bore
With Maximum Oversize Rods

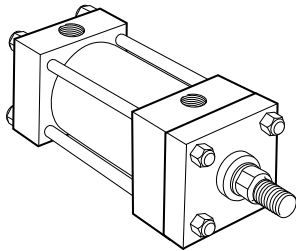

Retainer Held Gland

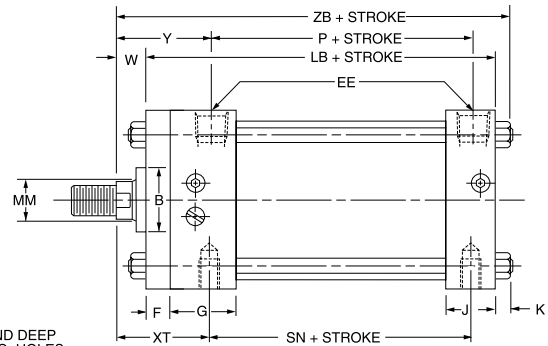
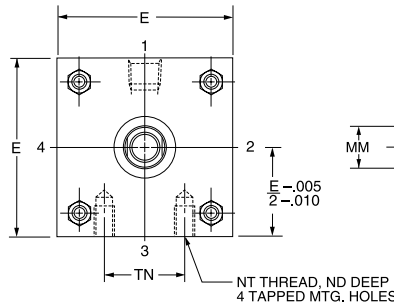

Before determining dimensions: See chart on page 3 for cylinder rod combinations that have a bolted gland.

**Side Tap Mount
Style FS**

1 1/2" - 6" Bore

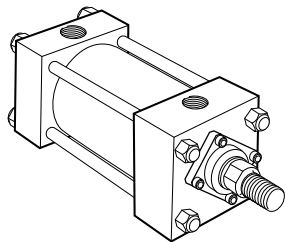

Bolted Gland

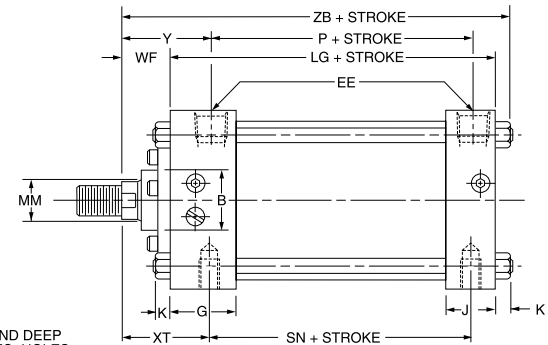
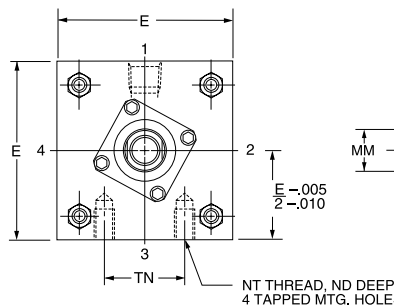

Rod End Dimensions (for Retainer Held Gland) — See Table 2

See chart on page 3 to determine which bore, rod, and mount combinations have this feature.

**Thread Style 1
Small Male**

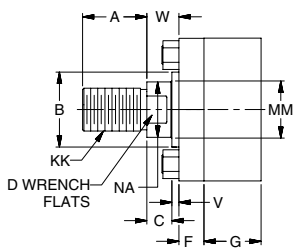

**Thread Style 2
Intermediate Male**

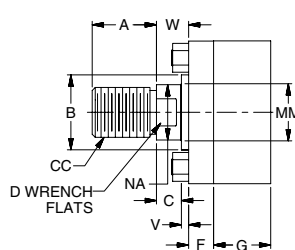

**Thread Style 3
Short Female**

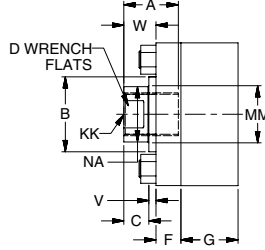

**Style 6
Stub End**

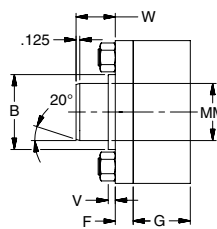

"Special" Thread Style 4

Special thread, extension, rod eye, blank, etc., are also available.

To order, specify "Style 4" and give desired dimensions for KK, A, W or WF. If otherwise special, furnish dimensioned sketch.

A high strength rod end stud is supplied on thread style 1 through 2" diameter rods. Larger sizes or special rod ends are cut threads. Style 1 rod ends are recommended where the workpiece is secured against the rod shoulder. When the workpiece is not shouldered,

style 1 rod ends are recommended through 2" piston rod diameters and style 2 rod ends are recommended on larger diameters. Use style 3 for applications where female rod end threads are required. If rod end is not specified, style 1 will be supplied.

Table 1—Envelope and Mounting Dimensions

Bore	E	EE		F	G	J	K	NT	TN	Add Stroke			
		NPTF [†]	SAE [*]							LB	LG	P	SN
1½	2	¾†	6‡	¾	1½	1	¼	¼-20	⅝	4	3⅝	2¼	2¼
2	2½	¾†	6	¾	1½	1	⅝	⅝-18	⅞	4	3⅝	2¼	2¼
2½	3	¾†	6	¾	1½	1	⅝	¾-16	1¼	4⅞	3¾	2⅝	2⅝
3¼	3¾	½	8	⅝	1¾	1¼	¾	½-13	1½	4⅞	4¼	2⅝	2⅝
4	4½	½	8	⅝	1¾	1¼	¾	½-13	2⅞	4⅞	4¼	2⅝	2⅝
5	5½	½	8	⅝	1¾	1¼	¾	⅝-11	2⅞	5⅞	4½	2⅝	2⅝
6	6½	¾	12	¾	2	1½	⅞	¾-10	3¼	5¾	5	3⅞	3⅞

† On 1½", 2" and 2½" bore sizes, the head-end (only) pipe thread is not full depth on cylinders with maximum oversize rods. Minimum of three full threads available. ‡ NPTF ports will be furnished as standard unless SAE straight thread ports are specified.

* SAE straight thread ports are indicated by port number.

‡ Straight thread ports. On 1½" bore size an adapter fitting is required on cap end and on head end with maximum oversize rod. (See "Straight Thread Port Adapter" drawing.) Adapters are furnished as standard.

Straight Thread Port Adapters

Used on 1 1/2" bore size only.

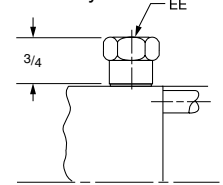

Table 2—Rod Dimensions

Bore	Rod Dia. MM	Thread		Rod Extensions and Pilot Dimensions										Add Stroke			
		Style 2 CC	Style 1 & 3 KK	A	+0.000 -0.002 B	C	D	NA	V	VA	VB	W	WF	XT	Y	ND	ZB
1½	⅝	½-20	⅞-20	¾	1.124	¾	½	9/16	—	¼	3/16	—	1	15/16	15/16	¾	47/8
	1	⅞-14	¾-16	1⅞	1.499	½	⅞	15/16	½	—	—	1	—	25/16	25/16	¾	5¼
2	⅝	½-20	⅞-20	¾	1.124	¾	½	9/16	—	¼	3/16	—	1	15/16	15/16	11/32	415/16
	1	⅞-14	¾-16	1⅞	1.499	½	⅞	15/16	—	¼	3/8	—	1¾	25/16	25/16	11/32	55/16
2½	⅞	1¼-12	1-14	1⅝	1.999	⅝	1⅞	15/16	⅝	—	—	1¼	—	29/16	29/16	11/32	59/16
	1	⅞-14	¾-16	1⅞	1.499	½	⅞	9/16	—	¼	3/8	—	1¾	25/16	25/16	7/16	51/16
	1⅞	1¼-12	1-14	1⅝	1.999	⅝	1⅞	15/16	⅝	—	—	1¼	—	29/16	29/16	7/16	511/16
3¼	1	⅞-14	¾-16	1⅞	1.499	½	⅞	9/16	—	¼	3/8	—	1¾	25/16	25/16	7/16	57/16
	1⅞	1¼-12	1-14	1⅝	1.999	⅝	1⅞	15/16	—	¼	9/16	—	1⅝	211/16	211/16	1/2	61/4
	1¾	1¼-12	1¼-12	2	2.374	¾	1½	11/16	¾	—	—	1½	—	213/16	213/16	7/16	515/16
4	1	⅞-14	¾-16	1⅞	1.499	½	⅞	9/16	—	¼	3/8	—	1¾	25/16	25/16	1/2	6
	1⅞	1¼-12	1-14	1⅝	1.999	⅝	1⅞	15/16	—	¼	9/16	—	1⅝	211/16	211/16	5/8	6¼
	1¾	1¼-12	1¼-12	2	2.374	¾	1½	11/16	—	¼	9/16	—	1⅞	215/16	215/16	5/8	6½
5	1	⅞-14	¾-16	1⅞	1.499	½	⅞	9/16	—	¼	3/8	—	1¾	25/16	25/16	5/8	65/8
	1⅞	1¼-12	1-14	1⅝	1.999	⅝	1⅞	15/16	—	¼	3/8	—	1⅞	211/16	211/16	¾	65/16
	1¾	1¼-12	1¼-12	2	2.374	¾	1½	11/16	—	¼	9/16	—	1⅞	215/16	215/16	¾	613/16
6	1	⅞-14	¾-16	1⅞	1.499	½	⅞	9/16	—	¼	3/8	—	1¾	25/16	25/16	¾	615/16
	1⅞	1¼-12	1-14	1⅝	1.999	⅝	1⅞	15/16	—	¼	9/16	—	1⅞	211/16	211/16	7/8	71/16
	1¾	1¼-12	1¼-12	2	2.374	¾	1½	11/16	—	¼	9/16	—	1⅞	215/16	215/16	7/8	75/16
2½	2	1¾-12	1½-12	2¼	2.624	⅞	1⅞	15/16	—	¼	9/16	—	2	31/16	31/16	¾	71/16
	2½	2¼-12	1⅞-12	3	3.124	1	2⅞	29/8	—	¼	11/16	—	2¼	37/16	37/16	7/8	711/16

Rod End Dimensions (for Bolted Gland) — See Table 2

See chart on page 3 to determine which bore, rod, and mount combinations have this feature.

Thread Style 1
Small Male

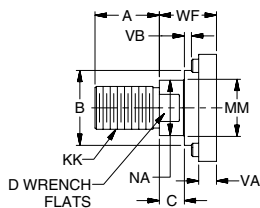

Thread Style 2
Intermediate Male

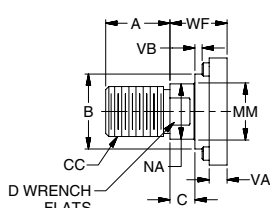

Thread Style 3
Short Female

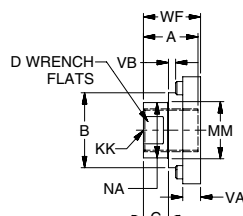

Style 6
Stub End

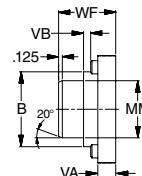

"Special" Thread Style 4

Special thread, extension, rod eye, blank, etc., are also available.

To order, specify "Style 4" and give desired dimensions for KK, A, W or WF. If otherwise special, furnish dimensioned sketch.

A high strength rod end stud is supplied on thread style 1 through 2" diameter rods. Larger sizes or special rod ends are cut threads. Style 1 rod ends are recommended where the workpiece is secured against the rod shoulder. When the workpiece is not shouldered,

style 1 rod ends are recommended through 2" piston rod diameters and style 2 rod ends are recommended on larger diameters. Use style 3 for applications where female rod end threads are required. If rod end is not specified, style 1 will be supplied.

**Head Rectangular Flange Mount
Style REF2**

1 1/2" - 6" Bore

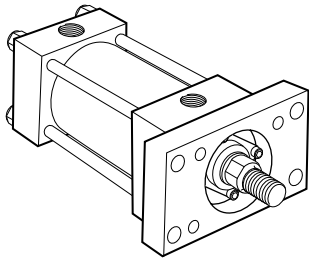

Bolted Gland

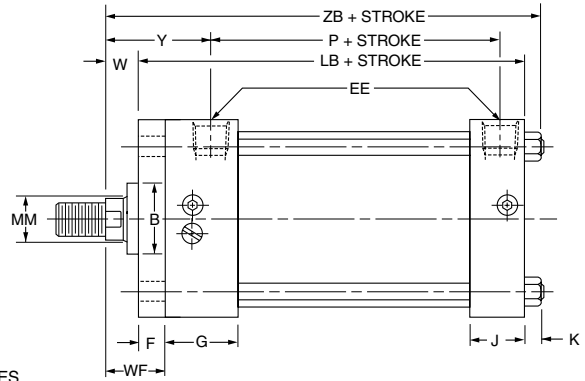
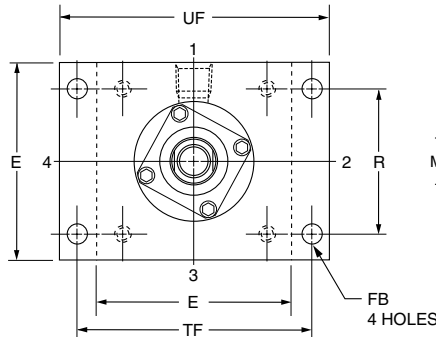

**Maximum Pressure Ratings
Push Application (Style REF2 only)**

Bore Dia.	Rod Dia.	PSI	Bore Dia.	Rod Dia.	PSI
1 1/2	5/8	1200	4	1	900
	1	700		1 3/8	750
2	5/8	450		1 3/4	500
	1	700		2	500
	1 3/8	400	1	600	
2 1/2	5/8	500	5	1 3/8	600
	1	300		1 3/4	500
	1 3/8	500		2	450
	1 3/4	300		1 3/8	700
3 1/4	1	1000	6	1 3/4	700
	1 3/8	650		2	700
	1 3/4	1000		2 1/2	600
	2	800			

Rod End Dimensions (for Retainer Held Gland) — See Table 2

See chart on page 3 to determine which bore, rod, and mount combinations have this feature.

**Thread Style 1
Small Male**

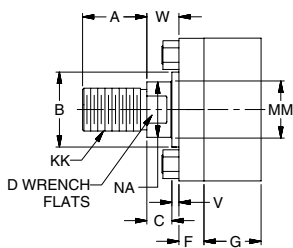

**Thread Style 2
Intermediate Male**

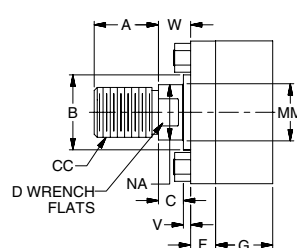

**Thread Style 3
Short Female**

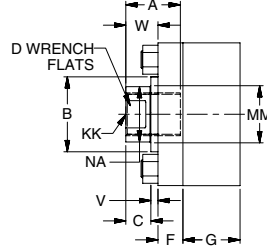

**Style 6
Stub End**

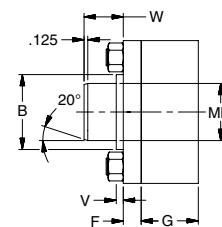

**“Special”
Thread Style 4**

Special thread, extension, rod eye, blank, etc., are also available.

To order, specify “Style 4” and give desired dimensions for KK, A, W or WF. If otherwise special, furnish dimensioned sketch.

A high strength rod end stud is supplied on thread style 1 through 2" diameter rods. Larger sizes or special rod ends are cut threads. Style 1 rod ends are recommended where the workpiece is secured against the rod shoulder. When the workpiece is not shouldered,

style 1 rod ends are recommended through 2" piston rod diameters and style 2 rod ends are recommended on larger diameters. Use style 3 for applications where female rod end threads are required. If rod end is not specified, style 1 will be supplied.

Table 1—Envelope and Mounting Dimensions

Bore	E	EE		F	FB	G	J	K	R	TF	UF	Add Stroke	
		NPTF [†]	SAE [*]									LB	P
1½	2	¾ [†]	6 [‡]	¾	5/16	1½	1	¼	1.43	2¾	3¾	4	2¼
2	2½	¾ [†]	6	¾	¾	1½	1	5/16	1.84	3¾	4½	4	2¼
2½	3	¾ [†]	6	¾	¾	1½	1	5/16	2.19	3¾	4½	4½	2¾
3¼	3¾	½	8	5/8	7/16	1¾	1¼	¾	2.76	4½	5½	4¾	2¾
4	4½	½	8	5/8	7/16	1¾	1¼	¾	3.32	5¾	6¼	4¾	2¾
5	5½	½	8	5/8	9/16	1¾	1¼	7/16	4.10	6¾	7½	5½	2¾
6	6½	¾	12	¾	9/16	2	1½	7/16	4.88	7¾	8½	5¾	3½

† On 1½", 2" and 2½" bore sizes, the head-end (only) pipe thread is not full depth on cylinders with maximum oversize rods. Minimum of three full threads available. ‡ NPTF ports will be furnished as standard unless SAE straight thread ports are specified.

* SAE straight thread ports are indicated by port number.

‡ Straight thread ports. On 1½" bore size an adapter fitting is required on cap end and on head end with maximum oversize rod. (See "Straight Thread Port Adapter" drawing.) Adapters are furnished as standard.

Straight Thread Port Adapters

Used on 1 1/2" bore size only.

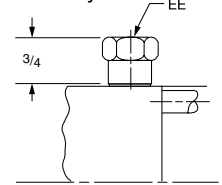

Table 2—Rod Dimensions

Bore	Rod Dia. MM	Thread		Rod Extensions and Pilot Dimensions								Add Stroke	
		Style 2 CC	Style 1 & 3 KK	A	+0.000 -0.002 B	C	D	NA	V	W	WF	Y	ZB
1½	5/8	1/2-20	7/16-20	¾	1.124	¾	½	9/16	¼	5/8	1	1½	4¾
	1	7/8-14	¾-16	1½	1.499	½	7/8	15/16	½	1	1¾	2½	5¼
2	5/8	1/2-20	7/16-20	¾	1.124	¾	½	9/16	¼	5/8	1	1½	4½
	1	7/8-14	¾-16	1½	1.499	½	7/8	15/16	½	1	1¾	2½	5½
	1¾	1¼-12	1-14	1½	1.999	5/8	1½	15/16	5/8	1¼	1½	2¾	5¾
2½	5/8	1/2-20	7/16-20	¾	1.124	¾	½	9/16	¼	5/8	1	1½	5½
	1	7/8-14	¾-16	1½	1.499	½	7/8	15/16	½	1	1¾	2½	5½
	1¾	1¼-12	1-14	1½	1.999	5/8	1½	15/16	5/8	1¼	1½	2¾	5½
	1¾	1½-12	1¼-12	2	2.374	¾	1½	11/16	¾	1½	1¾	2¾	5½
3¼	1	7/8-14	¾-16	1½	1.499	½	7/8	15/16	¼	¾	1¾	2¾	6
	1¾	1¼-12	1-14	1½	1.999	5/8	1½	15/16	¾	1	1½	2½	6¼
	1¾	1½-12	1¼-12	2	2.374	¾	1½	11/16	½	1¼	1¾	2½	6½
	2	1¾-12	1½-12	2¼	2.624	7/8	1½	11/16	½	1¾	2	3½	6½
4	1	7/8-14	¾-16	1½	1.499	½	7/8	15/16	¼	¾	1¾	2¾	6
	1¾	1¼-12	1-14	1½	1.999	5/8	1½	15/16	¾	1	1½	2½	6¼
	1¾	1½-12	1¼-12	2	2.374	¾	1½	11/16	½	1¼	1¾	2½	6½
	2	1¾-12	1½-12	2¼	2.624	7/8	1½	11/16	½	1¾	2	3½	6½
5	1	7/8-14	¾-16	1½	1.499	½	7/8	15/16	¼	¾	1¾	2¾	6½
	1¾	1¼-12	1-14	1½	1.999	5/8	1½	15/16	¾	1	1½	2½	6¾
	1¾	1½-12	1¼-12	2	2.374	¾	1½	11/16	½	1¼	1¾	2½	6¾
	2	1¾-12	1½-12	2¼	2.624	7/8	1½	11/16	½	1¾	2	3½	6¾
6	1¾	1¼-12	1-14	1½	1.999	5/8	1½	15/16	¼	7/8	1½	2¾	7½
	1¾	1½-12	1¼-12	2	2.374	¾	1½	11/16	¾	1½	1¾	3½	7½
	2	1¾-12	1½-12	2¼	2.624	7/8	1½	11/16	¾	1¼	2	3½	7½
	2½	2¼-12	1¾-12	3	3.124	1	2½	2¾	½	1½	2¼	3½	7½

Table 3—Envelope and Mounting Dimensions

Rod End Dimensions (for Bolted Gland) — See Table 2

See chart on page 3 to determine which bore, rod, and mount combinations have this feature.

Thread Style 1
Small Male

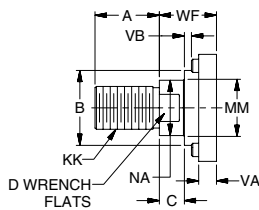

Thread Style 2
Intermediate Male

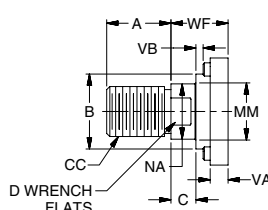

Thread Style 3
Short Female

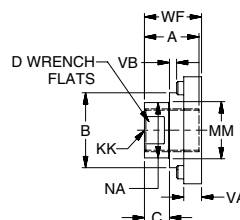

Style 6
Stub End

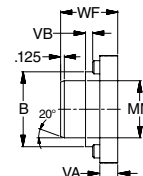

"Special" Thread Style 4

Special thread, extension, rod eye, blank, etc., are also available.

To order, specify "Style 4" and give desired dimensions for KK, A, W or WF. If otherwise special, furnish dimensioned sketch.

A high strength rod end stud is supplied on thread style 1 through 2" diameter rods. Larger sizes or special rod ends are cut threads. Style 1 rod ends are recommended where the workpiece is secured against the rod shoulder. When the workpiece is not shouldered,

style 1 rod ends are recommended through 2" piston rod diameters and style 2 rod ends are recommended on larger diameters. Use style 3 for applications where female rod end threads are required. If rod end is not specified, style 1 will be supplied.

**Cap Rectangular Flange Mount
Style BEF2**

1 1/2" - 2" and 2 1/2" Bore
With Maximum Oversize Rods

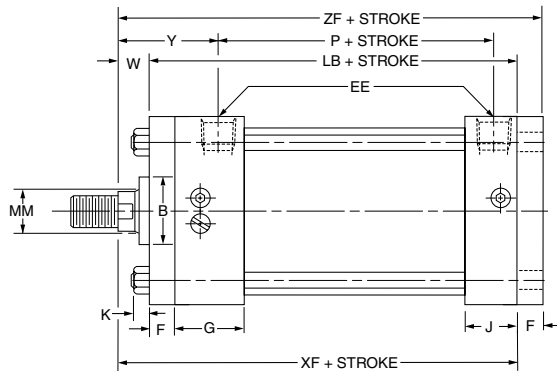
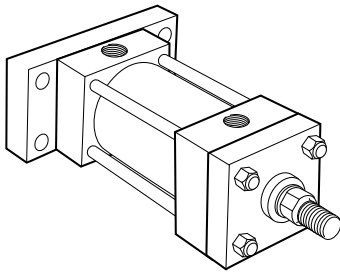

Retainer Held Gland

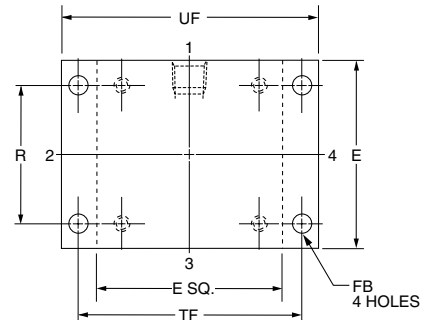

Before determining dimensions: See chart on page 3 for cylinder rod combinations that have a bolted gland.

**Cap Rectangular Flange Mount
Style BEF2**

1 1/2" - 6" Bore

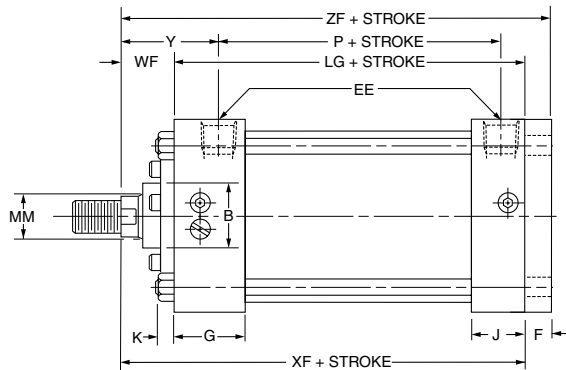
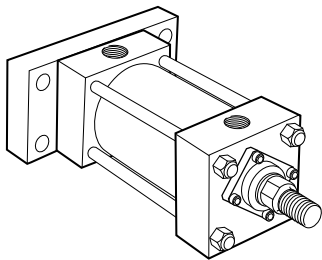

Bolted Gland

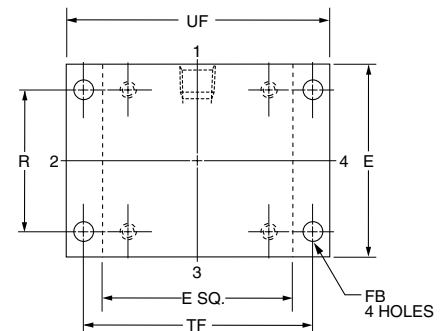

Rod End Dimensions (for Retainer Held Gland) — See Table 2

See chart on page 3 to determine which bore, rod, and mount combinations have this feature.

Thread Style 1
Small Male

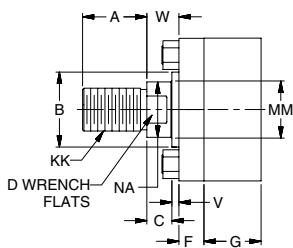

Thread Style 2
Intermediate Male

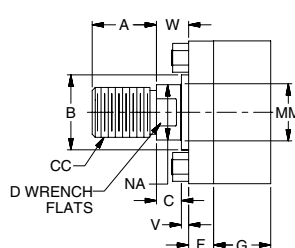

Thread Style 3
Short Female

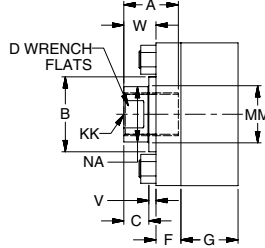

Style 6
Stub End

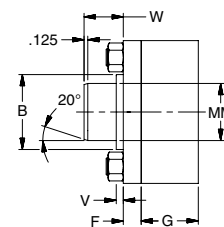

"Special" Thread Style 4

Special thread, extension, rod eye, blank, etc., are also available.

To order, specify "Style 4" and give desired dimensions for KK, A, W or WF. If otherwise special, furnish dimensioned sketch.

A high strength rod end stud is supplied on thread style 1 through 2" diameter rods. Larger sizes or special rod ends are cut threads. Style 1 rod ends are recommended where the workpiece is secured against the rod shoulder. When the workpiece is not shouldered,

style 1 rod ends are recommended through 2" piston rod diameters and style 2 rod ends are recommended on larger diameters. Use style 3 for applications where female rod end threads are required. If rod end is not specified, style 1 will be supplied.

Table 1—Envelope and Mounting Dimensions

Bore	E	EE		F	FB	G	J	K	R	TF	UF	Add Stroke		
		NPTF \ominus	SAE*									LB	LG	P
1½	2	¾†	6‡	¾	5/16	1½	1	¼	1.43	2¾	3¾	4	3½	2¼
2	2½	¾†	6	¾	¾	1½	1	5/16	1.84	3¾	4½	4	3½	2¼
2½	3	¾†	6	¾	¾	1½	1	5/16	2.19	3¾	4½	4½	3¾	2¾
3¼	3¾	½	8	5/8	7/16	1¾	1¼	¾	2.76	4½	5½	—	4¼	2½
4	4½	½	8	5/8	7/16	1¾	1¼	¾	3.32	5¾	6¼	—	4¼	2½
5	5½	½	8	5/8	9/16	1¾	1¼	7/16	4.10	6½	7½	5½	4½	2¾
6	6½	¾	12	¾	9/16	2	1½	7/16	4.88	7½	8½	5¾	5	3½

† On 1½", 2" and 2½" bore sizes, the head-end (only) pipe thread is not full depth on cylinders with maximum oversize rods. Minimum of three full threads available. \ominus NPTF ports will be furnished as standard unless SAE straight thread ports are specified.

* SAE straight thread ports are indicated by port number.

‡ Straight thread ports. On 1½" bore size an adapter fitting is required on cap end and on head end with maximum oversize rod. (See "Straight Thread Port Adapter" drawing.) Adapters are furnished as standard.

Straight Thread Port Adapters

Used on 1 ½" bore size only.

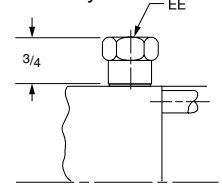

Table 2—Rod Dimensions

Bore	Rod Dia. MM	Thread		Rod Extensions and Pilot Dimensions										Add Stroke		
		Style 2 CC	Style 1 & 3 KK	A	+0.000 -0.002 B	C	D	NA	V	VA	VB	W	WF	Y	XF	ZF
1½	5/8	1/2-20	7/16-20	¾	1.124	¾	½	9/16	—	¼	¾	—	1	1½	4½	5
	1	7/8-14	¾-16	1½	1.499	½	7/8	15/16	½	—	—	1	—	2½	5	5½
2	5/8	1/2-20	7/16-20	¾	1.124	¾	½	9/16	—	¼	¾	—	1	1½	4½	5
	1	7/8-14	¾-16	1½	1.499	½	7/8	15/16	—	¼	¾	—	1¾	2½	5	5½
	1¾	1¼-12	1-14	1½	1.999	5/8	1½	15/16	5/8	—	—	1¼	—	2¾	5¼	5¾
2½	5/8	1/2-20	7/16-20	¾	1.124	¾	½	9/16	—	¼	¾	—	1	1½	4¾	5½
	1	7/8-14	¾-16	1½	1.499	½	7/8	15/16	—	¼	¾	—	1¾	2½	5½	5½
	1¾	1¼-12	1-14	1½	1.999	5/8	1½	15/16	5/8	—	—	1¼	—	2¾	5¾	5¾
	1¾	1½-12	1¼-12	2	2.374	¾	1½	1½	¾	—	—	1½	—	2½	5½	6
3¼	1	7/8-14	¾-16	1½	1.499	½	7/8	15/16	—	¼	¾	—	1¾	2¾	5½	6¼
	1¾	1¼-12	1-14	1½	1.999	5/8	1½	15/16	—	¼	¾	—	1½	2½	5¾	6½
	1¾	1½-12	1¼-12	2	2.374	¾	1½	1½	—	¼	¾	—	1¾	2½	6½	6¾
	2	1¾-12	1½-12	2¼	2.624	7/8	1½	15/16	—	¼	¾	—	2	3½	6¼	6¾
4	1	7/8-14	¾-16	1½	1.499	½	7/8	15/16	—	¼	¾	—	1¾	2¾	5½	6¼
	1¾	1¼-12	1-14	1½	1.999	5/8	1½	15/16	—	¼	¾	—	1½	2½	5¾	6½
	1¾	1½-12	1¼-12	2	2.374	¾	1½	1½	—	¼	¾	—	1¾	2½	6½	6¾
	2	1¾-12	1½-12	2¼	2.624	7/8	1½	15/16	—	¼	¾	—	2	3½	6¼	6¾
5	1	7/8-14	¾-16	1½	1.499	½	7/8	15/16	—	¼	¾	—	1¾	2¾	5½	6½
	1¾	1¼-12	1-14	1½	1.999	5/8	1½	15/16	—	¼	¾	—	1½	2½	6½	6¾
	1¾	1½-12	1¼-12	2	2.374	¾	1½	1½	—	¼	¾	—	1¾	2½	6¾	7
	2	1¾-12	1½-12	2¼	2.624	7/8	1½	15/16	—	¼	¾	—	2	3½	6½	7½
6	1¾	1¼-12	1-14	1½	1.999	5/8	1½	15/16	—	¼	¾	—	1½	2½	6¾	7¾
	1¾	1½-12	1¼-12	2	2.374	¾	1½	1½	—	¼	¾	—	1¾	2½	6¾	7¾
	2	1¾-12	1½-12	2¼	2.624	7/8	1½	15/16	—	¼	¾	—	2	3½	7	7¾
	2½	2¼-12	1¾-12	3	3.124	1	2¼	2¾	—	¼	¾	—	2¼	3¾	7¼	8

Rod End Dimensions (for Bolted Gland) — See Table 2

See chart on page 3 to determine which bore, rod, and mount combinations have this feature.

Thread Style 1
Small Male

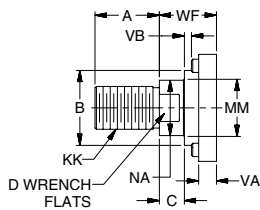

Thread Style 2
Intermediate Male

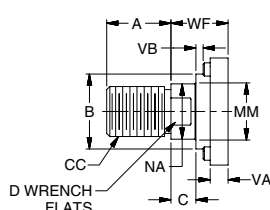

Thread Style 3
Short Female

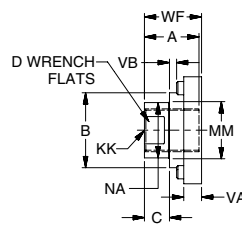

Style 6
Stub End

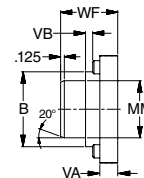

"Special" Thread Style 4

Special thread, extension, rod eye, blank, etc., are also available.

To order, specify "Style 4" and give desired dimensions for KK, A, W or WF. If otherwise special, furnish dimensioned sketch.

A high strength rod end stud is supplied on thread style 1 through 2" diameter rods. Larger sizes or special rod ends are cut threads. Style 1 rod ends are recommended where the workpiece is secured against the rod shoulder. When the workpiece is not shouldered,

style 1 rod ends are recommended through 2" piston rod diameters and style 2 rod ends are recommended on larger diameters. Use style 3 for applications where female rod end threads are required. If rod end is not specified, style 1 will be supplied.

Head Square Flange Mount
Style REF1
1 1/2" - 6" Bore

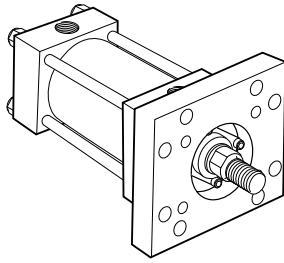

Bolted Gland

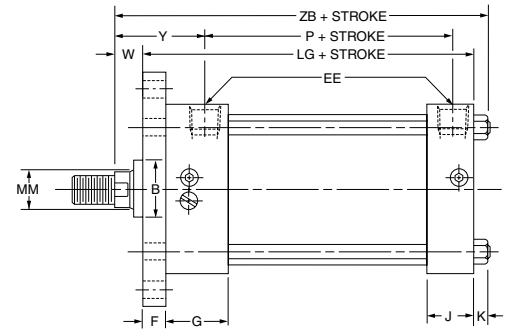
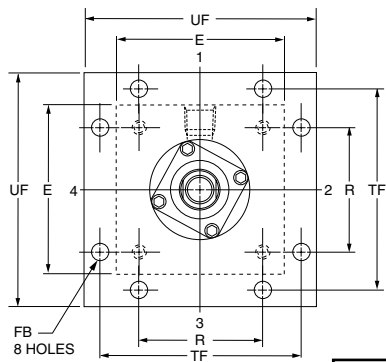

Before determining dimensions: See chart on page 3 for cylinder rod combinations that have a bolted gland.

Cap Square Flange Mount
Style BEF1
1 1/2" - 2" and 2 1/2" Bore
With Maximum Oversize Rods

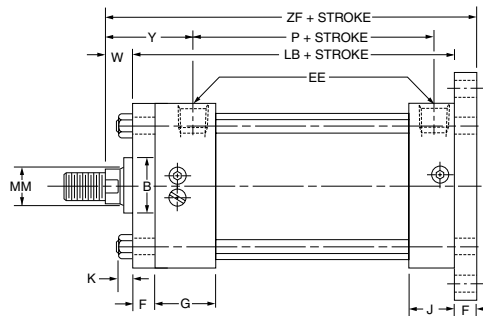
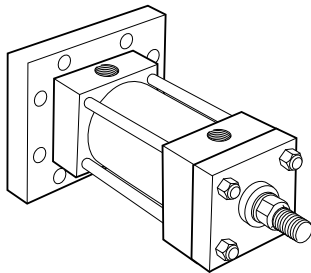

Retainer Held Gland

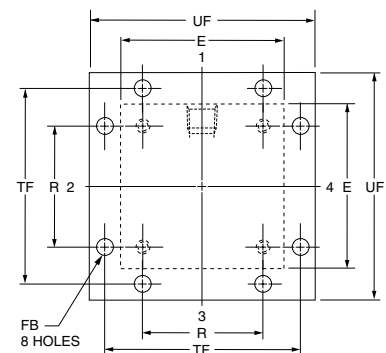

Cap Square Flange Mount
Style BEF1
1 1/2" - 6" Bore

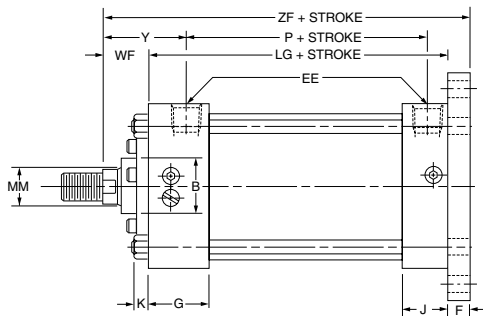
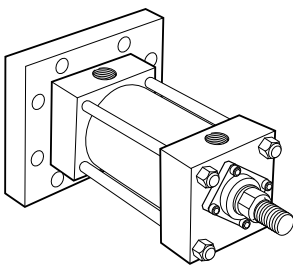

Bolted Gland

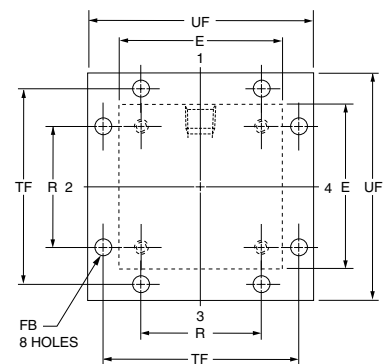

Rod End Dimensions (for Retainer Held Gland) — See Table 2

See chart on page 3 to determine which bore, rod, and mount combinations have this feature.

Thread Style 1
Small Male

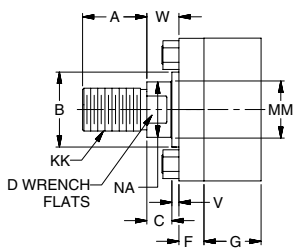

Thread Style 2
Intermediate Male

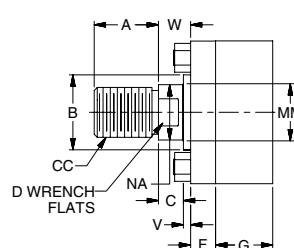

Thread Style 3
Short Female

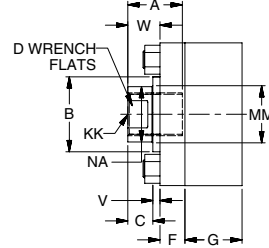

Style 6
Stub End

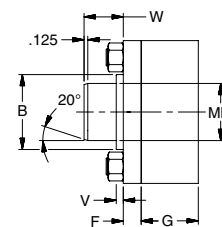

"Special" Thread Style 4

Special thread, extension, rod eye, blank, etc., are also available. To order, specify "Style 4" and give desired dimensions for KK, A, W or WF. If otherwise special, furnish dimensioned sketch.

A high strength rod end stud is supplied on thread style 1 through 2" diameter rods. Larger sizes or special rod ends are cut threads. Style 1 rod ends are recommended where the workpiece is secured against the rod shoulder. When the workpiece is not shouldered,

style 1 rod ends are recommended through 2" piston rod diameters and style 2 rod ends are recommended on larger diameters. Use style 3 for applications where female rod end threads are required. If rod end is not specified, style 1 will be supplied.

Table 1—Envelope and Mounting Dimensions

Bore	E	EE		F	FB	G	J	K	R	TF	UF	Add Stroke		
		NPTF \ominus	SAE*									LB	LG	P
1½	2	¾†	6‡	¾	5/16	1½	1	¼	1.43	2¾	3¾	4	3½	2¼
2	2½	¾†	6	¾	¾	1½	1	5/16	1.84	3¾	4½	4	3½	2¼
2½	3	¾†	6	¾	¾	1½	1	5/16	2.19	3¾	4½	4½	3¾	2¾
3¼	3¾	½	8	5/8	7/16	1¾	1¼	¾	2.76	4½	5½	4¾	4¼	2¾
4	4½	½	8	5/8	7/16	1¾	1¼	¾	3.32	5½	6¼	4¾	4¼	2¾
5	5½	½	8	5/8	9/16	1¾	1¼	7/16	4.10	6½	7½	5½	4½	2¾
6	6½	¾	12	¾	9/16	2	1½	7/16	4.88	7½	8½	5¾	5	3½

† On 1½", 2" and 2½" bore sizes, the head-end (only) pipe thread is not full depth on cylinders with maximum oversize rods. Minimum of three full threads available. \ominus NPTF ports will be furnished as standard unless SAE straight thread ports are specified.

* SAE straight thread ports are indicated by port number.

‡ Straight thread ports. On 1½" bore size an adapter fitting is required on cap end and on head end with maximum oversize rod. (See "Straight Thread Port Adapter" drawing.) Adapters are furnished as standard.

Straight Thread Port Adapters

Used on 1 ½" bore size only.

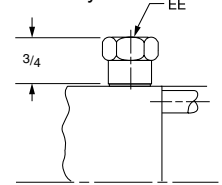

Table 2—Rod Dimensions

Bore	Rod Dia. MM	Thread		Rod Extensions and Pilot Dimensions										Add Stroke		
		Style 4 CC	Style 2 & 3 KK	A	+0.000 -0.002 B	C	D	NA	V	VA	VB	W	WF	Y	ZB	ZF
1½	5/8	1/2-20	7/16-20	¾	1.124	¾	½	9/16	1/4**	¼	3/16	¼	1	1½	4¾	5
	1	7/8-14	¾-16	1½	1.499	½	7/8	15/16	½	¼	—	1	—	2½	5¼	5½
2	5/8	1/2-20	7/16-20	¾	1.124	¾	½	9/16	1/4**	¼	3/16	5/8	1	1½	4½	5
	1	7/8-14	¾-16	1½	1.499	½	7/8	15/16	½	¼	3/8	1	1¾	2½	5½	5½
2½	1¾	1¼-12	1-14	1½	1.999	5/8	1½	15/16	5/8	—	—	1¼	—	2¾	5¾	5¾
	5/8	1/2-20	7/16-20	¾	1.124	¾	½	9/16	1/4**	¼	3/16	5/8	1	1½	5½	5½
3¼	1	7/8-14	¾-16	1½	1.499	½	7/8	15/16	1/4**	¼	3/8	¾	1¾	2¾	6	6¼
	1¾	1¼-12	1-14	1½	1.999	5/8	1½	15/16	3/8**	¼	½	1	1½	2½	6¼	6½
4	1¾	1¼-12	1-14	2	2.374	¾	1½	1½	1/2**	¼	9/16	1¼	1¾	2½	6½	6¾
	5/8	1/2-20	7/16-20	¾	1.124	¾	½	9/16	1/4**	¼	3/16	5/8	1	1½	5½	5½
5	1	7/8-14	¾-16	1½	1.499	½	7/8	15/16	1/4**	¼	3/8	¾	1¾	2¾	6	6¼
	1¾	1¼-12	1-14	1½	1.999	5/8	1½	15/16	3/8**	¼	½	1	1½	2½	6¼	6½
6	1¾	1¼-12	1-14	2	2.374	¾	1½	1½	1/2**	¼	9/16	1¾	2	2½	6½	6¾
	5/8	1/2-20	7/16-20	¾	1.124	¾	½	9/16	1/4**	¼	3/8	¾	1¾	2¾	6½	6¾

** For all REF1 mounts and BEF1 mounts with maximum oversized rods.

Rod End Dimensions (for Bolted Gland) — See Table 2

See chart on page 3 to determine which bore, rod, and mount combinations have this feature.

Thread Style 1
Small Male

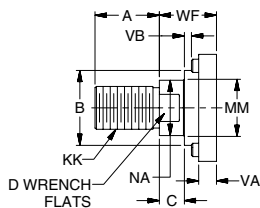

Thread Style 2
Intermediate Male

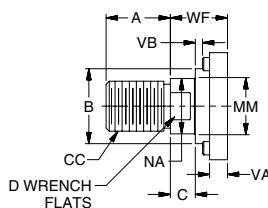

Thread Style 3
Short Female

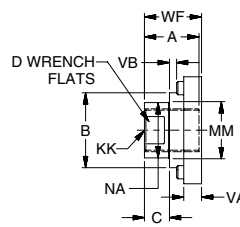

Style 6
Stub End

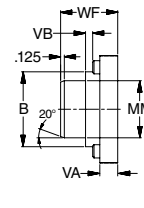

"Special" Thread Style 4

Special thread, extension, rod eye, blank, etc., are also available.

To order, specify "Style 4" and give desired dimensions for KK, A, W or WF. If otherwise special, furnish dimensioned sketch.

A high strength rod end stud is supplied on thread style 1 through 2" diameter rods. Larger sizes or special rod ends are cut threads. Style 1 rod ends are recommended where the workpiece is secured against the rod shoulder. When the workpiece is not shouldered,

style 1 rod ends are recommended through 2" piston rod diameters and style 2 rod ends are recommended on larger diameters. Use style 3 for applications where female rod end threads are required. If rod end is not specified, style 1 will be supplied.

Tie Rods Extended Mount

Style NM1

1 1/2" - 2" and 2 1/2" Bore – All Rod Sizes

3 1/4" Bore with 1 3/4" & 2" Rods

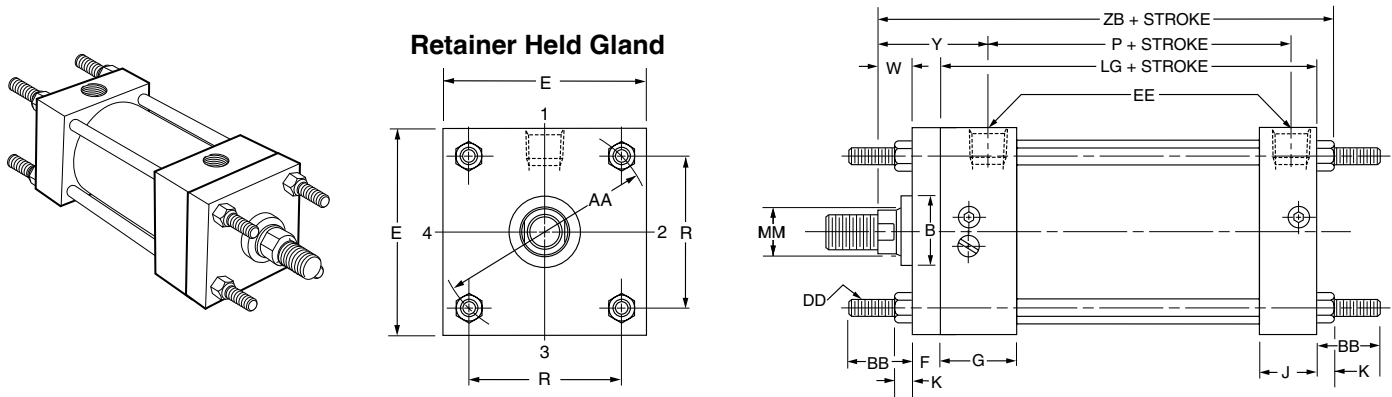

Tie Rods can be extended: Both Ends — Model NM1;
Cap End — Model NM2; Head End — Model NM3.

Before determining dimensions: See chart on page 3 for
cylinder rod combinations that have a bolted gland.

Tie Rods Extended Mount

Style NM1

1 1/2" - 6" Bore

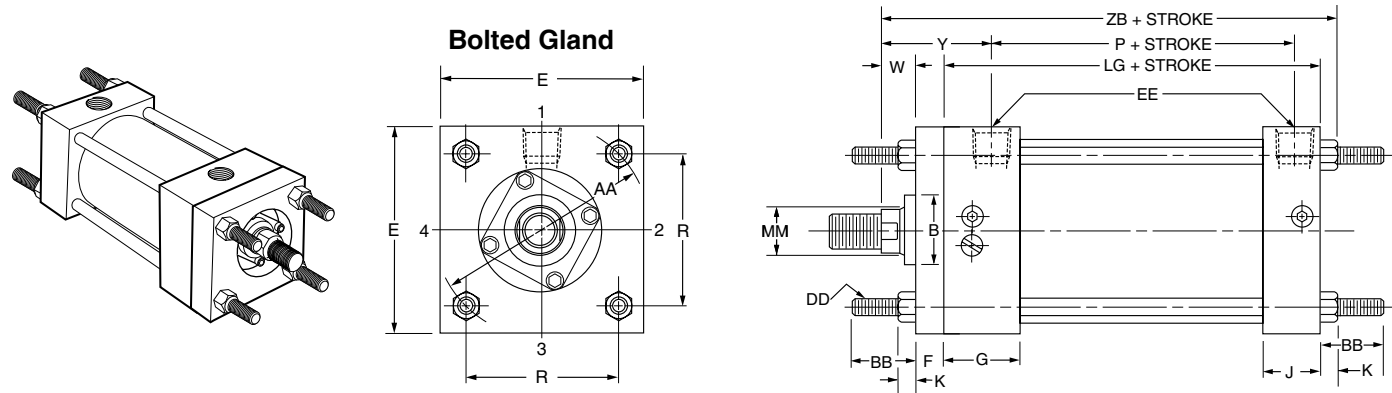

Rod End Dimensions (for Retainer Held Gland) — See Table 2

See chart on page 3 to determine which bore, rod, and mount combinations have this feature.

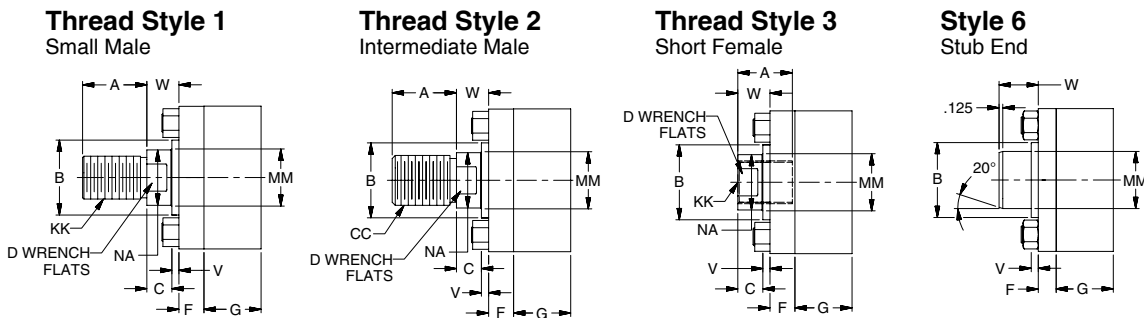

“Special” Thread Style 4

Special thread, extension, rod eye, blank, etc., are also available.

To order, specify “Style 4” and give desired dimensions for KK, A, W or WF. If otherwise special, furnish dimensioned sketch.

A high strength rod end stud is supplied on thread style 1 through 2" diameter rods. Larger sizes or special rod ends are cut threads. Style 1 rod ends are recommended where the workpiece is secured against the rod shoulder. When the workpiece is not shouldered,

style 1 rod ends are recommended through 2" piston rod diameters and style 2 rod ends are recommended on larger diameters. Use style 3 for applications where female rod end threads are required. If rod end is not specified, style 1 will be supplied.

Table 1—Envelope and Mounting Dimensions

Bore	AA	BB	DD	E	EE		F	G	J	K	R	Add Stroke	
					NPTF [†]	SAE [*]						LG	P
1 1/2	2.02	1	1/4-28	2	3/8 [†]	6 [‡]	3/8	1 1/2	1	1/4	1.43	3 5/8	2 1/4
2	2.6	1 1/8	5/16-24	2 1/2	3/8 [†]	6	3/8	1 1/2	1	5/16	1.84	3 5/8	2 1/4
2 1/2	3.1	1 1/8	5/16-24	3	3/8 [†]	6	3/8	1 1/2	1	5/16	2.19	3 3/4	2 3/8
3 1/4	3.9	1 3/8	3/8-24	3 3/4	1/2	8	—	1 3/4	1 1/4	3/8	2.76	4 1/4	2 5/8
4	4.7	1 3/8	3/8-24	4 1/2	1/2	8	—	1 3/4	1 1/4	3/8	3.32	4 1/4	2 5/8
5	5.8	1 13/16	1/2-20	5 1/2	1/2	8	5/8	1 3/4	1 1/4	7/16	4.10	4 1/2	2 7/8
6	6.9	1 13/16	1/2-20	6 1/2	3/4	12	3/4	2	1 1/2	7/16	4.88	5	3 1/8

[†] On 1 1/2", 2" and 2 1/2" bore sizes, the head-end (only) pipe thread is not full depth on cylinders with maximum oversize rods. Minimum of three full threads available. [‡] NPTF ports will be furnished as standard unless SAE straight thread ports are specified.

^{*} SAE straight thread ports are indicated by port number.

[‡] Straight thread ports. On 1 1/2" bore size an adapter fitting is required on cap end and on head end with maximum oversize rod. (See "Straight Thread Port Adapter" drawing.) Adapters are furnished as standard.

Straight Thread Port Adapters

Used on 1 1/2" bore size only.

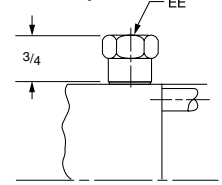

Table 2—Rod Dimensions

Bore	Rod Dia. MM	Thread		Rod Extensions and Pilot Dimensions										Add Stroke	
		Style 2 CC	Style 1 & 3 KK	A	+ .000 - .002 B	C	D	NA	V	VA	VB	W	WF	Y	ZB
1 1/2	5/8	1/2-20	7/16-20	3/4	1.124	3/8	1/2	9/16	—	1/4	3/16	—	1	1 15/16	4 7/8
	1	7/8-14	3/4-16	1 1/8	1.499	1/2	7/8	15/16	1/2	—	—	1	—	2 5/16	5 1/4
2	5/8	1/2-20	7/16-20	3/4	1.124	3/8	1/2	9/16	—	1/4	3/16	—	1	1 15/16	4 15/16
	1	7/8-14	3/4-16	1 1/8	1.499	1/2	7/8	15/16	—	1/4	3/8	—	1 3/8	2 5/16	5 5/16
	1 3/8	1 1/4-12	1-14	1 5/8	1.999	5/8	1 1/8	1 5/16	5/8	—	—	1 1/4	—	2 9/16	5 9/16
2 1/2	5/8	1/2-20	7/16-20	3/4	1.124	3/8	1/2	9/16	—	1/4	3/16	—	1	1 15/16	5 1/16
	1	7/8-14	3/4-16	1 1/8	1.499	1/2	7/8	15/16	—	1/4	3/8	—	1 3/8	2 5/16	5 7/16
	1 3/8	1 1/4-12	1-14	1 5/8	1.999	5/8	1 1/8	1 5/16	5/8	—	—	1 1/4	—	2 9/16	5 11/16
	1 3/4	1 1/2-12	1 1/4-12	2	2.374	3/4	1 1/2	1 11/16	3/4	—	—	1 1/2	—	2 13/16	5 15/16
3 1/4	1	7/8-14	3/4-16	1 1/8	1.499	1/2	7/8	15/16	—	1/4	3/8	—	1 3/8	2 7/16	6
	1 3/8	1 1/4-12	1-14	1 5/8	1.999	5/8	1 1/8	1 5/16	—	1/4	1/2	—	1 5/8	2 11/16	6 1/4
	1 3/4	1 1/2-12	1 1/4-12	2	2.374	3/4	1 1/2	1 11/16	—	1/4	9/16	—	1 7/8	2 15/16	6 1/2
	2	1 3/4-12	1 1/2-12	2 1/4	2.624	7/8	1 11/16	1 5/16	—	1/4	9/16	—	2	3 1/16	6 5/8
4	1	7/8-14	3/4-16	1 1/8	1.499	1/2	7/8	15/16	—	1/4	3/8	—	1 3/8	2 7/16	6
	1 3/8	1 1/4-12	1-14	1 5/8	1.999	5/8	1 1/8	1 5/16	—	1/4	1/2	—	1 5/8	2 11/16	6 1/4
	1 3/4	1 1/2-12	1 1/4-12	2	2.374	3/4	1 1/2	1 11/16	—	1/4	9/16	—	1 7/8	2 15/16	6 1/2
	2	1 3/4-12	1 1/2-12	2 1/4	2.624	7/8	1 11/16	1 5/16	—	1/4	9/16	—	2	3 1/16	6 5/8
5	1	7/8-14	3/4-16	1 1/8	1.499	1/2	7/8	15/16	—	1/4	3/8	—	1 3/8	2 7/16	6 5/16
	1 3/8	1 1/4-12	1-14	1 5/8	1.999	5/8	1 1/8	1 5/16	—	1/4	1/2	—	1 5/8	2 11/16	6 9/16
	1 3/4	1 1/2-12	1 1/4-12	2	2.374	3/4	1 1/2	1 11/16	—	1/4	9/16	—	1 7/8	2 15/16	6 13/16
	2	1 3/4-12	1 1/2-12	2 1/4	2.624	7/8	1 11/16	1 5/16	—	1/4	9/16	—	2	3 1/16	6 15/16
6	1 3/8	1 1/4-12	1-14	1 5/8	1.999	5/8	1 1/8	1 5/16	—	1/4	7/16	—	1 5/8	2 13/16	7 1/16
	1 3/4	1 1/2-12	1 1/4-12	2	2.374	3/4	1 1/2	1 11/16	—	1/4	9/16	—	1 7/8	3 1/16	7 5/16
	2	1 3/4-12	1 1/2-12	2 1/4	2.624	7/8	1 11/16	1 5/16	—	1/4	9/16	—	2	3 3/16	7 7/16
	2 1/2	2 1/4-12	1 7/8-12	3	3.124	1	2 1/16	2 3/8	—	1/4	1 1/16	—	2 1/4	3 7/16	7 11/16

Rod End Dimensions (for Bolted Gland) — See Table 2

See chart on page 3 to determine which bore, rod, and mount combinations have this feature.

Thread Style 1
Small Male

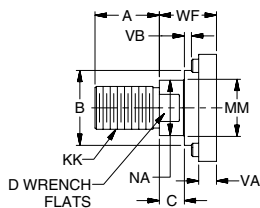

Thread Style 2
Intermediate Male

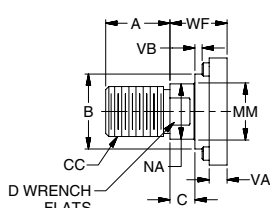

Thread Style 3
Short Female

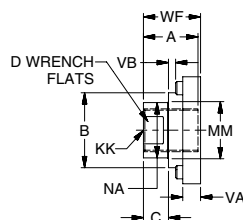

Style 6
Stub End

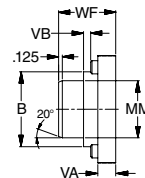

"Special" Thread Style 4

Special thread, extension, rod eye, blank, etc., are also available.

To order, specify "Style 4" and give desired dimensions for KK, A, W or WF. If otherwise special, furnish dimensioned sketch.

A high strength rod end stud is supplied on thread style 1 through 2" diameter rods. Larger sizes or special rod ends are cut threads. Style 1 rod ends are recommended where the workpiece is secured against the rod shoulder. When the workpiece is not shouldered,

style 1 rod ends are recommended through 2" piston rod diameters and style 2 rod ends are recommended on larger diameters. Use style 3 for applications where female rod end threads are required. If rod end is not specified, style 1 will be supplied.

**Head Trunnion Mount
Style TM1**

1 1/2" - 2" and 2 1/2" Bore
With Maximum Oversize Rods

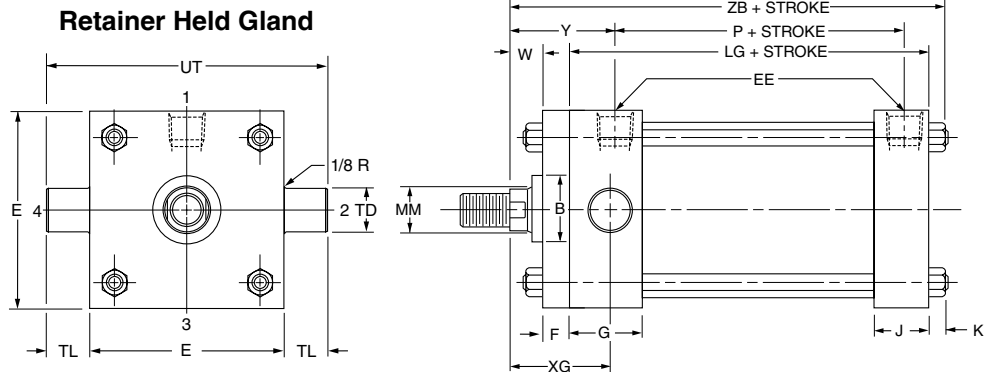
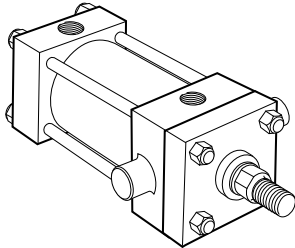

Before determining dimensions: See chart on page 3 for cylinder rod combinations that have a bolted gland.

**Head Trunnion Mount
Style TM1**

1 1/2" - 6" Bore

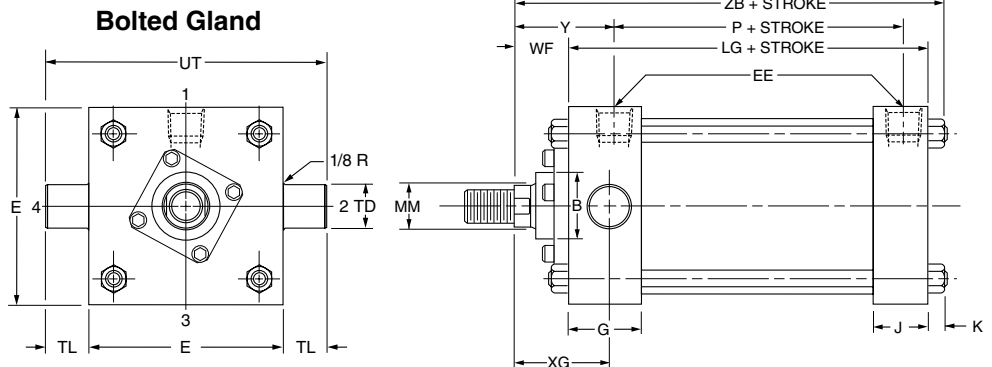
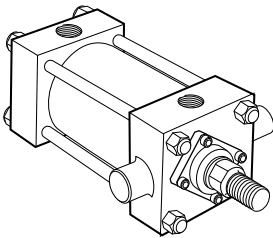

Rod End Dimensions (for Retainer Held Gland) — See Table 2

See chart on page 3 to determine which bore, rod, and mount combinations have this feature.

Thread Style 1
Small Male

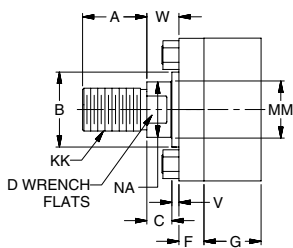

Thread Style 2
Intermediate Male

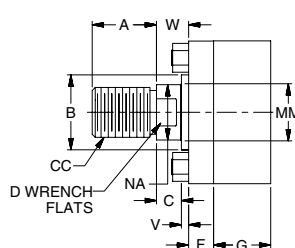

Thread Style 3
Short Female

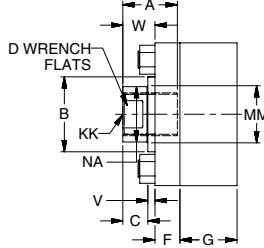

Style 6
Stub End

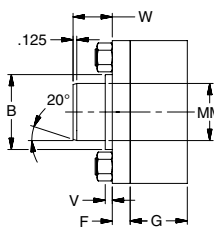

"Special" Thread Style 4

Special thread, extension, rod eye, blank, etc., are also available.

To order, specify "Style 4" and give desired dimensions for KK, A, W or WF. If otherwise special, furnish dimensioned sketch.

A high strength rod end stud is supplied on thread style 1 through 2" diameter rods. Larger sizes or special rod ends are cut threads. Style 1 rod ends are recommended where the workpiece is secured against the rod shoulder. When the workpiece is not shouldered,

style 1 rod ends are recommended through 2" piston rod diameters and style 2 rod ends are recommended on larger diameters. Use style 3 for applications where female rod end threads are required. If rod end is not specified, style 1 will be supplied.

Table 1—Envelope and Mounting Dimensions

Bore	E	EE		F	G	J	K	+.000 TD -.001	TL	UT	Add Stroke	
		NPTF [†]	SAE [*]								LG	P
1 1/2	2	3/8 [†]	6 [‡]	3/8	1 1/2	1	1/4	1.000	1	4	3 5/8	2 1/4
2	2 1/2	3/8 [†]	6	3/8	1 1/2	1	5/16	1.000	1	4 1/2	3 5/8	2 1/4
2 1/2	3	3/8 [†]	6	3/8	1 1/2	1	5/16	1.000	1	5	3 3/4	2 3/8
3 1/4	3 3/4	1/2	8	—	1 3/4	1 1/4	3/8	1.000	1	5 3/4	4 1/4	2 5/8
4	4 1/2	1/2	8	—	1 3/4	1 1/4	3/8	1.000	1	6 1/2	4 1/4	2 5/8
5	5 1/2	1/2	8	5/8	1 3/4	1 1/4	7/16	1.000	1	7 1/2	4 1/2	2 7/8
6	6 1/2	3/4	12	3/4	2	1 1/2	7/16	1.375	1 3/8	9 1/4	5	3 1/8

† On 1 1/2", 2" and 2 1/2" bore sizes, the head-end (only) pipe thread is not full depth on cylinders with maximum oversize rods. Minimum of three full threads available. ‡ NPTF ports will be furnished as standard unless SAE straight thread ports are specified.

* SAE straight thread ports are indicated by port number.

‡ Straight thread ports. On 1 1/2" bore size an adapter fitting is required on cap end and on head end with maximum oversize rod. (See "Straight Thread Port Adapter" drawing.) Adapters are furnished as standard.

Straight Thread Port Adapters

Used on 1 1/2" bore size only.

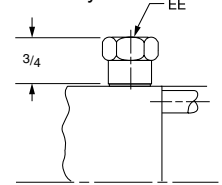

Table 2—Rod Dimensions

Bore	Rod Dia. MM	Thread		Rod Extensions and Pilot Dimensions										Add Stroke		
		Style 2 CC	Style 1 & 3 KK	A	+.000 -.002 B	C	D	NA	V	VA	VB	W	WF	XG	Y	ZB
1 1/2	5/8	1/2-20	7/16-20	3/4	1.124	3/8	1/2	9/16	—	1/4	3/16	—	1	1 3/4	1 15/16	4 7/8
	1	7/8-14	3/4-16	1 1/8	1.499	1/2	7/8	15/16	1/2	—	—	—	1	2 1/8	2 5/16	5 1/4
2	5/8	1/2-20	7/16-20	3/4	1.124	3/8	1/2	9/16	—	1/4	3/16	—	1	1 3/4	1 15/16	4 15/16
	1	7/8-14	3/4-16	1 1/8	1.499	1/2	7/8	15/16	—	1/4	3/8	—	1 3/8	2 1/8	2 5/16	5 5/16
2 1/2	1 3/8	1 1/4-12	1-14	1 5/8	1.999	5/8	1 1/8	1 5/16	5/8	—	—	1 1/4	—	2 3/8	2 9/16	5 9/16
	1 3/8	1 1/4-12	1-14	1 5/8	1.999	5/8	1 1/8	1 5/16	5/8	—	—	1 1/4	—	2 3/8	2 9/16	5 11/16
3 1/4	1 3/4	1 1/2-12	1 1/4-12	2	2.374	3/4	1 1/2	1 11/16	3/4	—	—	1 1/2	—	2 5/8	2 13/16	5 15/16
	1 3/4	1 1/2-12	1 1/4-12	2	2.374	3/4	1 1/2	1 11/16	—	1/4	1/2	—	1 7/8	2 3/4	2 15/16	6 1/2
4	1	7/8-14	3/4-16	1 1/8	1.499	1/2	7/8	15/16	—	1/4	3/8	—	1 3/8	2 1/4	2 7/16	6
	1 3/8	1 1/4-12	1-14	1 5/8	1.999	5/8	1 1/8	1 5/16	—	1/4	1/2	—	1 5/8	2 1/2	2 11/16	6 1/4
5	1 3/4	1 1/2-12	1 1/4-12	2	2.624	7/8	1 11/16	1 15/16	—	1/4	9/16	—	2	2 7/8	3 1/16	6 5/8
	1 3/4	1 1/2-12	1 1/4-12	2	2.624	7/8	1 11/16	1 15/16	—	1/4	9/16	—	2	2 7/8	3 1/16	6 5/8
6	1	7/8-14	3/4-16	1 1/8	1.499	1/2	7/8	15/16	—	1/4	3/8	—	1 3/8	2 1/4	2 7/16	6 5/16
	1 3/4	1 1/2-12	1 1/4-12	2	2.374	3/4	1 1/2	1 11/16	—	1/4	1/2	—	1 5/8	2 1/2	2 11/16	6 9/16
6	1 3/4	1 1/2-12	1 1/4-12	2	2.374	3/4	1 1/2	1 11/16	—	1/4	9/16	—	1 7/8	2 3/4	2 15/16	6 13/16
	2	1 3/4-12	1 1/2-12	2 1/4	2.624	7/8	1 11/16	1 15/16	—	1/4	9/16	—	2	2 7/8	3 1/16	6 15/16
6	1 3/8	1 1/4-12	1-14	1 5/8	1.999	5/8	1 1/8	1 5/16	—	1/4	7/16	—	1 5/8	2 5/8	2 13/16	7 1/16
	1 3/4	1 1/2-12	1 1/4-12	2	2.374	3/4	1 1/2	1 11/16	—	1/4	9/16	—	1 7/8	2 7/8	3 1/16	7 5/16
6	2	1 3/4-12	1 1/2-12	2 1/4	2.624	7/8	1 11/16	1 15/16	—	1/4	9/16	—	2	3	3 3/16	7 7/16
	2 1/2	2 1/4-12	1 7/8-12	3	3.124	1	2 1/16	2 3/8	—	1/4	1 1/16	—	2 1/4	3 1/4	3 7/16	7 11/16

Rod End Dimensions (for Bolted Gland) — See Table 2

See chart on page 3 to determine which bore, rod, and mount combinations have this feature.

Thread Style 1
Small Male

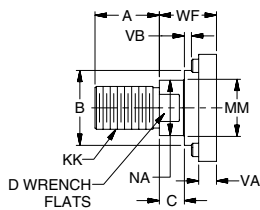

Thread Style 2
Intermediate Male

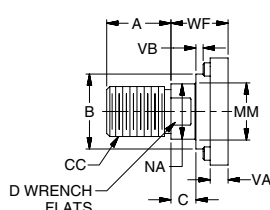

Thread Style 3
Short Female

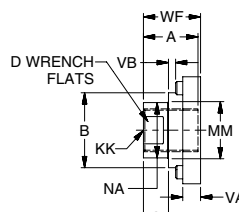

Style 6
Stub End

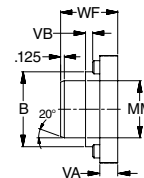

"Special" Thread Style 4

Special thread, extension, rod eye, blank, etc., are also available.

To order, specify "Style 4" and give desired dimensions for KK, A, W or WF. If otherwise special, furnish dimensioned sketch.

A high strength rod end stud is supplied on thread style 1 through 2" diameter rods. Larger sizes or special rod ends are cut threads. Style 1 rod ends are recommended where the workpiece is secured against the rod shoulder. When the workpiece is not shouldered,

style 1 rod ends are recommended through 2" piston rod diameters and style 2 rod ends are recommended on larger diameters. Use style 3 for applications where female rod end threads are required. If rod end is not specified, style 1 will be supplied.

Cap Trunnion Mount

Style TM2

1 1/2" - 2" and 2 1/2" Bore
With Maximum Oversize Rods

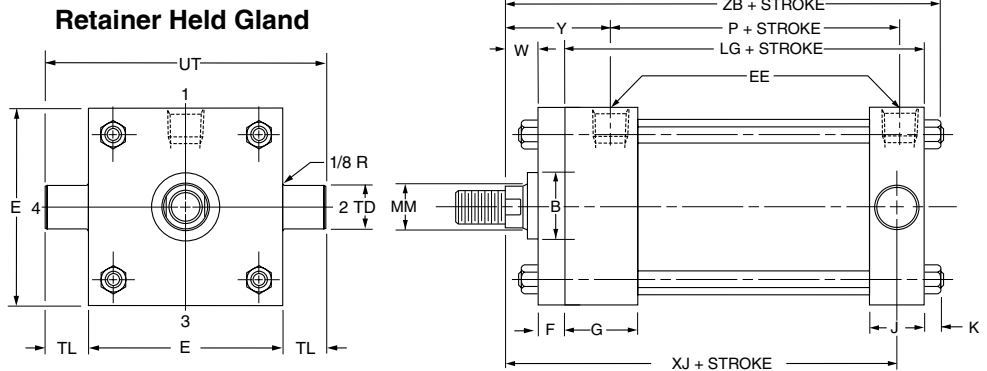
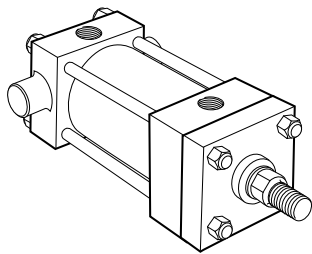

Before determining dimensions: See chart on page 3 for cylinder rod combinations that have a bolted gland.

Cap Trunnion Mount
Style TM2

1 1/2" - 6" Bore

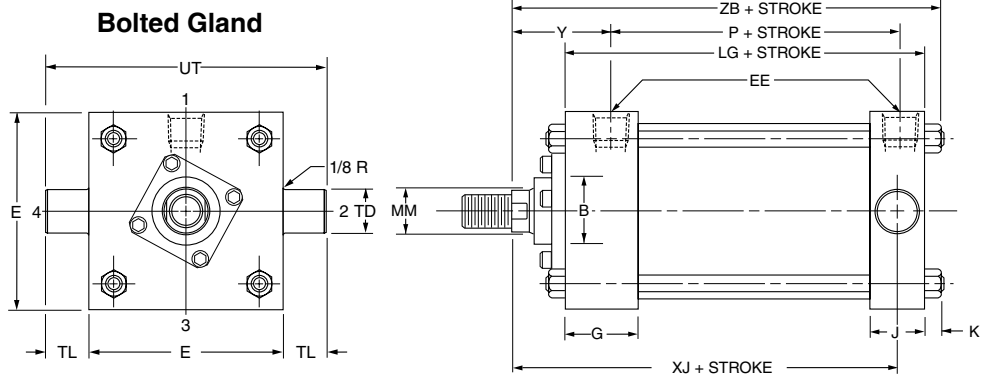
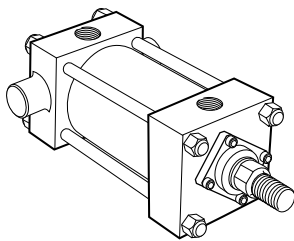

Rod End Dimensions (for Retainer Held Gland) — See Table 2

See chart on page 3 to determine which bore, rod, and mount combinations have this feature.

Thread Style 1
Small Male

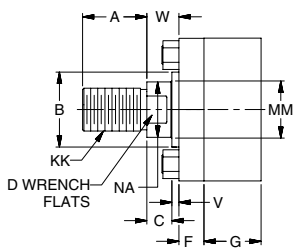

Thread Style 2
Intermediate Male

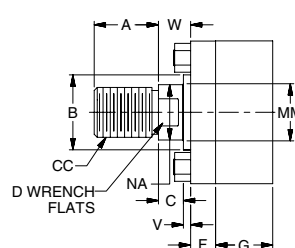

Thread Style 3
Short Female

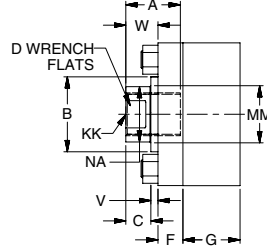

Style 6
Stub End

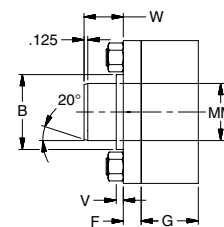

"Special" Thread Style 4

Special thread, extension, rod eye, blank, etc., are also available.

To order, specify "Style 4" and give desired dimensions for KK, A, W or WF. If otherwise special, furnish dimensioned sketch.

A high strength rod end stud is supplied on thread style 1 through 2" diameter rods. Larger sizes or special rod ends are cut threads. Style 1 rod ends are recommended where the workpiece is secured against the rod shoulder. When the workpiece is not shouldered,

style 1 rod ends are recommended through 2" piston rod diameters and style 2 rod ends are recommended on larger diameters. Use style 3 for applications where female rod end threads are required. If rod end is not specified, style 1 will be supplied.

Table 1—Envelope and Mounting Dimensions

Bore	E	EE		F	G	J	K	+.000 TD -.001	TL	UT	Add Stroke	
		NPTF \ominus	SAE*								LG	P
1 1/2	2	3/8†	6‡	3/8	1 1/2	1	1/4	1.000	1	4	3 5/8	2 1/4
2	2 1/2	3/8†	6	3/8	1 1/2	1	5/16	1.000	1	4 1/2	3 5/8	2 1/4
2 1/2	3	3/8†	6	3/8	1 1/2	1	5/16	1.000	1	5	3 3/4	2 3/8
3 1/4	3 3/4	1/2	8	—	1 3/4	1 1/4	3/8	1.000	1	5 3/4	4 1/4	2 5/8
4	4 1/2	1/2	8	—	1 3/4	1 1/4	3/8	1.000	1	6 1/2	4 1/4	2 5/8
5	5 1/2	1/2	8	5/8	1 3/4	1 1/4	7/16	1.000	1	7 1/2	4 1/2	2 7/8
6	6 1/2	3/4	12	3/4	2	1 1/2	7/16	1.375	1 3/8	9 1/4	5	3 1/8

† On 1 1/2", 2" and 2 1/2" bore sizes, the head-end (only) pipe thread is not full depth on cylinders with maximum oversize rods. Minimum of three full threads available. \ominus NPTF ports will be furnished as standard unless SAE straight thread ports are specified.

* SAE straight thread ports are indicated by port number.

‡ Straight thread ports. On 1 1/2" bore size an adapter fitting is required on cap end and on head end with maximum oversize rod. (See "Straight Thread Port Adapter" drawing.) Adapters are furnished as standard.

Straight Thread Port Adapters

Used on 1 1/2" bore size only.

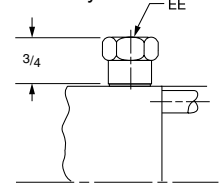

Table 2—Rod Dimensions

Bore	Rod Dia. MM	Thread		Rod Extensions and Pilot Dimensions										Add Stroke		
		Style 2 CC	Style 1 & 3 KK	A	+.000 -.002 B	C	D	NA	V	VA	VB	W	WF	Y	XJ	ZB
1 1/2	5/8	1/2-20	7/16-20	3/4	1.124	3/8	1/2	9/16	—	1/4	3/16	—	1	1 15/16	4 1/8	4 7/8
	1	7/8-14	3/4-16	1 1/8	1.499	1/2	7/8	15/16	1/2	—	—	1	—	2 5/16	4 1/2	5 1/4
2	5/8	1/2-20	7/16-20	3/4	1.124	3/8	1/2	9/16	—	1/4	3/16	—	1	1 15/16	4 1/8	4 5/16
	1	7/8-14	3/4-16	1 1/8	1.499	1/2	7/8	15/16	—	1/4	3/8	—	1 3/8	2 5/16	4 1/2	5 5/16
2 1/2	1 3/8	1 1/4-12	1-14	1 5/8	1.999	5/8	1 1/8	1 5/16	5/8	—	—	1 1/4	—	2 9/16	4 3/4	5 9/16
	1 3/4	1 1/2-12	1 1/4-12	2	2.374	3/4	1 1/2	1 11/16	3/4	—	—	1 1/2	—	2 13/16	5 1/8	5 15/16
3 1/4	1	7/8-14	3/4-16	1 1/8	1.499	1/2	7/8	15/16	—	1/4	3/8	—	1 3/8	2 7/16	5	6
	1 3/8	1 1/4-12	1-14	1 5/8	1.999	5/8	1 1/8	1 5/16	—	1/4	1/2	—	1 5/8	2 11/16	5 1/4	6 1/4
4	1 3/4	1 1/2-12	1 1/4-12	2	2.374	3/4	1 1/2	1 11/16	—	1/4	9/16	—	1 7/8	2 15/16	5 1/2	6 1/2
	2	1 3/4-12	1 1/2-12	2 1/4	2.624	7/8	1 11/16	1 5/16	—	1/4	9/16	—	2	3 1/16	5 5/8	6 5/8
5	1	7/8-14	3/4-16	1 1/8	1.499	1/2	7/8	15/16	—	1/4	3/8	—	1 3/8	2 7/16	5 1/4	6 5/16
	1 3/8	1 1/4-12	1-14	1 5/8	1.999	5/8	1 1/8	1 5/16	—	1/4	1/2	—	1 5/8	2 11/16	5 1/2	6 9/16
6	1 3/4	1 1/2-12	1 1/4-12	2	2.374	3/4	1 1/2	1 11/16	—	1/4	9/16	—	1 7/8	2 15/16	5 3/4	6 9/16
	2	1 3/4-12	1 1/2-12	2 1/4	2.624	7/8	1 11/16	1 5/16	—	1/4	9/16	—	2	3 1/16	5 7/8	6 15/16

Table 3—Envelope and Mounting Dimensions

Rod End Dimensions (for Bolted Gland) — See Table 2

See chart on page 3 to determine which bore, rod, and mount combinations have this feature.

Thread Style 1
Small Male

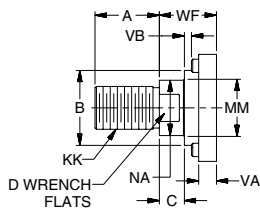

Thread Style 2
Intermediate Male

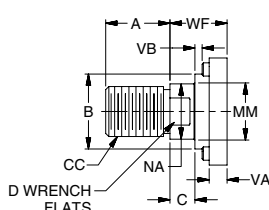

Thread Style 3
Short Female

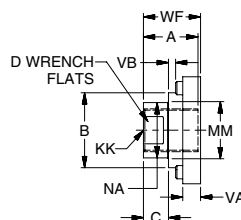

Style 6
Stub End

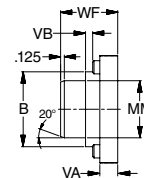

"Special" Thread Style 4

Special thread, extension, rod eye, blank, etc., are also available.

To order, specify "Style 4" and give desired dimensions for KK, A, W or WF. If otherwise special, furnish dimensioned sketch.

A high strength rod end stud is supplied on thread style 1 through 2" diameter rods. Larger sizes or special rod ends are cut threads. Style 1 rod ends are recommended where the workpiece is secured against the rod shoulder. When the workpiece is not shouldered,

style 1 rod ends are recommended through 2" piston rod diameters and style 2 rod ends are recommended on larger diameters. Use style 3 for applications where female rod end threads are required. If rod end is not specified, style 1 will be supplied.

**Intermediate Fixed Trunnion Mount
 Style TM3**
 1 1/2" - 2" and 2 1/2" Bore
 With Maximum Oversize Rods

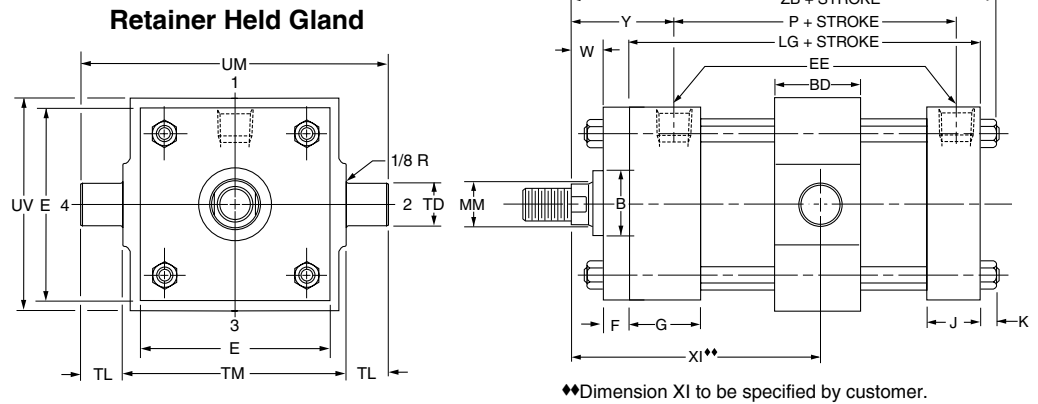
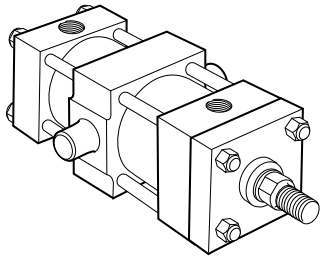

Before determining dimensions: See chart on page 3 for cylinder rod combinations that have a bolted gland.

**Intermediate Fixed Trunnion Mount
 Style TM3**
 1 1/2" - 6" Bore

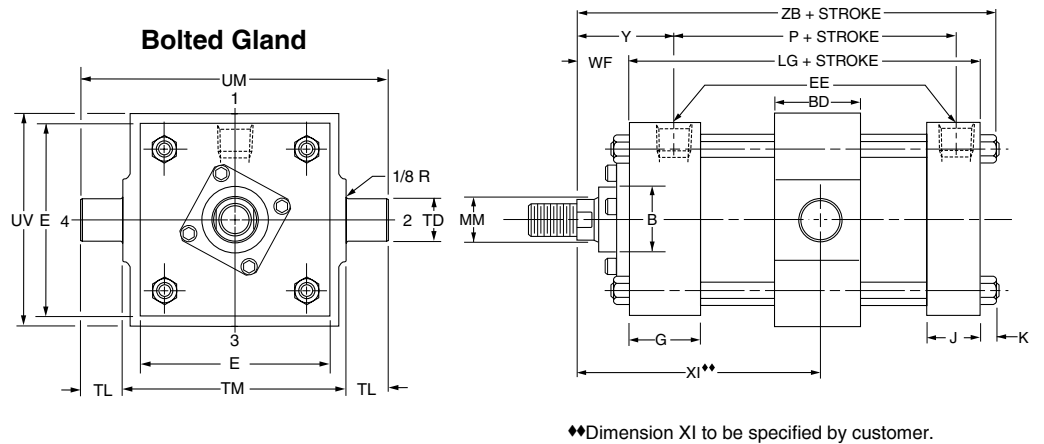
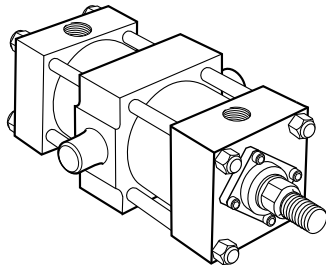

Rod End Dimensions (for Retainer Held Gland) — See Table 2

See chart on page 3 to determine which bore, rod, and mount combinations have this feature.

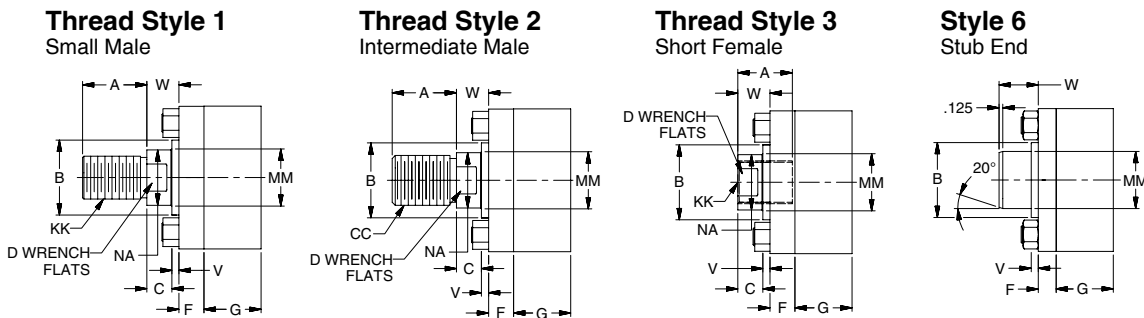

A high strength rod end stud is supplied on thread style 1 through 2" diameter rods. Larger sizes or special rod ends are cut threads. Style 1 rod ends are recommended where the workpiece is secured against the rod shoulder. When the workpiece is not shouldered,

style 1 rod ends are recommended through 2" piston rod diameters and style 2 rod ends are recommended on larger diameters. Use style 3 for applications where female rod end threads are required. If rod end is not specified, style 1 will be supplied.

Table 1—Envelope and Mounting Dimensions

Bore	BD	E	EE		F	G	J	K	+0.000 TD -.001	TL	TM	UM	UV	Minimum Stroke	Add Stroke	
			NPTF [†]	SAE [*]											LG	P
1 1/2	1 1/4	2	3/8 [†]	6 [‡]	3/8	1 1/2	1	1/4	1.000	1	2 1/2	4 1/2	2 1/2	1/4	3 5/8	2 1/4
2	1 1/2	2 1/2	3/8 [†]	6	3/8	1 1/2	1	5/16	1.000	1	3	5	3	1/2	3 5/8	2 1/4
2 1/2	1 1/2	3	3/8 [†]	6	3/8	1 1/2	1	5/16	1.000	1	3 1/2	5 1/2	3 1/2	3/8	3 3/4	2 3/8
3 1/4	2	3 3/4	1/2	8	5/8	1 3/4	1 1/4	3/8	1.000	1	4 1/2	6 1/2	4 1/4	7/8	4 1/4	2 5/8
4	2	4 1/2	1/2	8	—	1 3/4	1 1/4	3/8	1.000	1	5 1/4	7 1/4	5	7/8	4 1/4	2 5/8
5	2	5 1/2	1/2	8	—	1 3/4	1 1/4	7/16	1.000	1	6 1/4	8 1/4	6	5/8	4 1/2	2 7/8
6	2 1/2	6 1/2	3/4	12	3/4	2	1 1/2	7/16	1.375	1 3/8	7 5/8	10 3/8	7	1 1/8	5	3 1/8

† On 1 1/2", 2" and 2 1/2" bore sizes, the head-end (only) pipe thread is not full depth on cylinders with maximum oversize rods. Minimum of three full threads available. ‡ NPTF ports will be furnished as standard unless SAE straight thread ports are specified.

* SAE straight thread ports are indicated by port number.

‡ Straight thread ports. On 1 1/2" bore size an adapter fitting is required on cap end and on head end with maximum oversize rod. (See "Straight Thread Port Adapter" drawing.) Adapters are furnished as standard.

Straight Thread Port Adapters

Used on 1 1/2" bore size only.

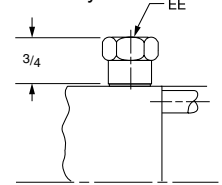

Table 2—Rod Dimensions

Bore	Rod Dia. MM	Thread		Rod Extensions and Pilot Dimensions											Min. XI	Y	Add Stroke ZB
		Style 2 CC	Style 1 & 3 KK	A	+0.000 -0.002 B	C	D	NA	V	VA	VB	W	WF				
1 1/2	5/8	1/2-20	7/16-20	3/4	1.124	3/8	1/2	9/16	—	1/4	3/16	—	1	3 3/16	1 15/16	4 7/8	
	1	7/8-14	3/4-16	1 1/8	1.499	1/2	7/8	15/16	1/2	—	—	—	1	3 9/16	2 5/16	5 1/4	
2	5/8	1/2-20	7/16-20	3/4	1.124	3/8	1/2	9/16	—	1/4	3/16	—	1	3 5/16	1 15/16	4 15/16	
	1	7/8-14	3/4-16	1 1/8	1.499	1/2	7/8	15/16	—	1/4	3/8	—	1 3/8	3 11/16	2 5/16	5 5/16	
2 1/2	1 3/8	1 1/4-12	1-14	1 5/8	1.999	5/8	1 1/8	1 5/16	5/8	—	—	1 1/4	—	3 15/16	2 9/16	5 9/16	
	1 5/8	1 1/2-12	1 1/4-12	2	2.374	3/4	1 1/2	1 11/16	3/4	—	—	1 1/2	—	4 3/16	2 13/16	5 15/16	
3 1/4	1	7/8-14	3/4-16	1 1/8	1.499	1/2	7/8	15/16	—	1/4	3/8	—	1 3/8	4 3/16	2 7/16	6	
	1 3/8	1 1/4-12	1-14	1 5/8	1.999	5/8	1 1/8	1 5/16	—	1/4	1/2	—	1 5/8	4 7/16	2 11/16	6 1/4	
4	1 3/4	1 1/2-12	1 1/4-12	2	2.374	3/4	1 1/2	1 11/16	—	1/4	9/16	—	1 7/8	4 11/16	2 15/16	6 1/2	
	2	1 3/4-12	1 1/2-12	2 1/4	2.624	7/8	1 11/16	1 15/16	—	1/4	9/16	—	2	4 13/16	3 1/16	6 5/8	
5	1	7/8-14	3/4-16	1 1/8	1.499	1/2	7/8	15/16	—	1/4	3/8	—	1 3/8	4 3/16	2 7/16	6	
	1 3/8	1 1/4-12	1-14	1 5/8	1.999	5/8	1 1/8	1 5/16	—	1/4	1/2	—	1 5/8	4 7/16	2 11/16	6 1/4	
6	1 3/4	1 1/2-12	1 1/4-12	2	2.374	3/4	1 1/2	1 11/16	—	1/4	9/16	—	1 7/8	4 11/16	2 15/16	6 1/2	
	2	1 3/4-12	1 1/2-12	2 1/4	2.624	7/8	1 11/16	1 15/16	—	1/4	9/16	—	2	4 13/16	3 1/16	6 5/8	

♦♦ Dimension XI to be specified by customer.

Rod End Dimensions (for Bolted Gland) — See Table 2

See chart on page 3 to determine which bore, rod, and mount combinations have this feature.

Thread Style 1
Small Male

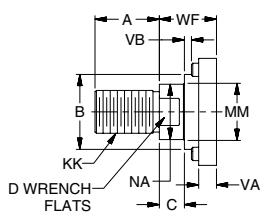

Thread Style 2
Intermediate Male

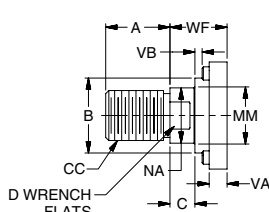

Thread Style 3
Short Female

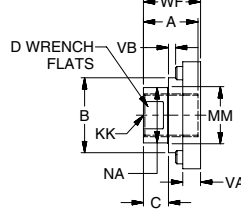

Style 6
Stub End

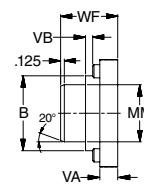

"Special" Thread Style 4
Stub End

Special thread, extension, rod eye, blank, etc., are also available.

To order, specify "Style 4" and give desired dimensions for KK, A, W or WF. If otherwise special, furnish dimensioned sketch.

A high strength rod end stud is supplied on thread style 1 through 2" diameter rods. Larger sizes or special rod ends are cut threads. Style 1 rod ends are recommended where the workpiece is secured against the rod shoulder. When the workpiece is not shouldered,

style 1 rod ends are recommended through 2" piston rod diameters and style 2 rod ends are recommended on larger diameters. Use style 3 for applications where female rod end threads are required. If rod end is not specified, style 1 will be supplied.

**Cap Fixed Clevis Mount
Style PB2**

1 1/2" - 2" and 2 1/2" Bore
With Maximum Oversize Rods

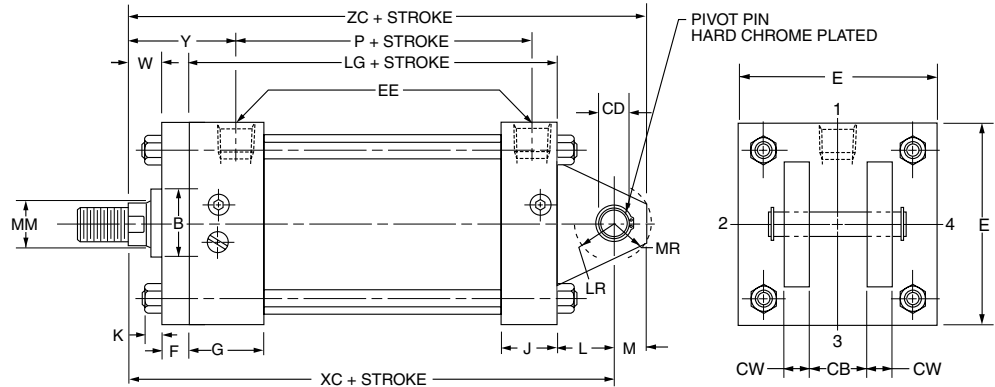
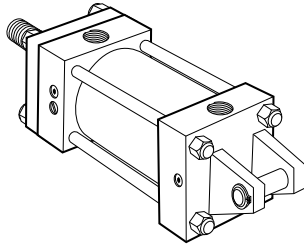

The 4", 5" and 6" bore sizes have the tie rod nuts at both ends as shown. Tie rods thread into cap on all other bore sizes.

Before determining dimensions: See chart on page 3 for cylinder rod combinations that have a bolted gland.

**Cap Fixed Clevis Mount
Style PB2**

1 1/2" - 6" Bore

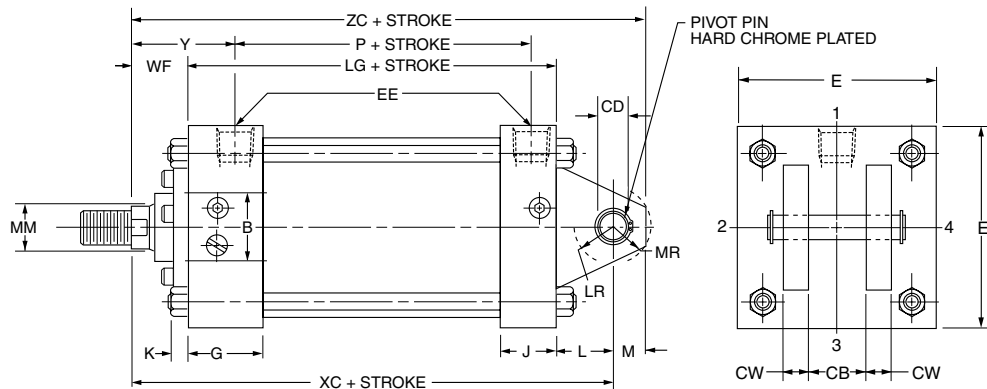
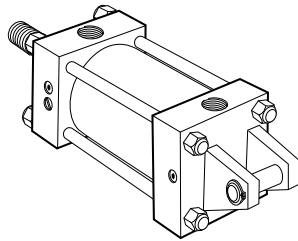

The 4", 5" and 6" bore sizes have the tie rod nuts at both ends as shown. Tie rods thread into cap on all other bore sizes.

Rod End Dimensions (for Retainer Held Gland) — See Table 2

See chart on page 3 to determine which bore, rod, and mount combinations have this feature.

Thread Style 1
Small Male

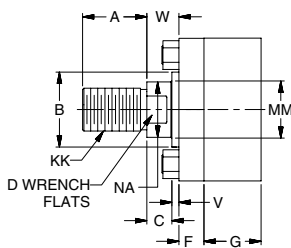

Thread Style 2
Intermediate Male

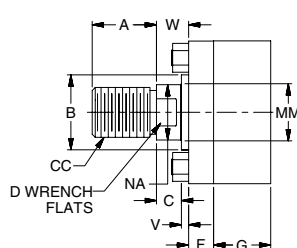

Thread Style 3
Short Female

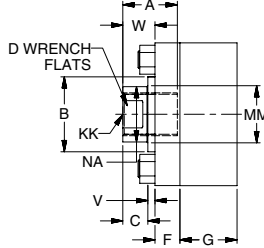

Style 6
Stub End

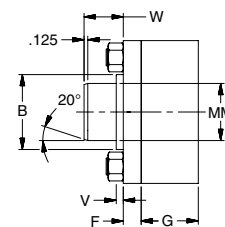

"Special" Thread Style 4

Special thread, extension, rod eye, blank, etc., are also available. To order, specify "Style 4" and give desired dimensions for KK, A, W or WF. If otherwise special, furnish dimensioned sketch.

A high strength rod end stud is supplied on thread style 1 through 2" diameter rods. Larger sizes or special rod ends are cut threads. Style 1 rod ends are recommended where the workpiece is secured against the rod shoulder. When the workpiece is not shouldered,

style 1 rod ends are recommended through 2" piston rod diameters and style 2 rod ends are recommended on larger diameters. Use style 3 for applications where female rod end threads are required. If rod end is not specified, style 1 will be supplied.

Table 1—Envelope and Mounting Dimensions

Bore	CB	+.000 CD• -.002	CW	E	EE		F	G	J	K	L	LR	M	MR	Add Stroke	
					NPTF⊖	SAE*									LG	P
1½	¾	.501	½	2	¾†	6‡	¾	1½	1	¼	¾	¾	½	5/8	3⅝	2¼
2	¾	.501	½	2½	¾†	6	¾	1½	1	5/16	¾	¾	½	5/8	3⅝	2¼
2½	¾	.501	½	3	¾†	6	¾	1½	1	5/16	¾	¾	½	5/8	3¾	2⅝
3¼	1¼	.751	5/8	3¾	½	8	—	1¾	1¼	¾	1¼	1	¾	15/16	4¼	2⅝
4	1¼	.751	5/8	4½	½	8	—	1¾	1¼	¾	1¼	1	¾	15/16	4¼	2⅝
5	1¼	.751	5/8	5½	½	8	5/8	1¾	1¼	7/16	1¼	1	¾	15/16	4½	2⅞
6	1½	1.001	¾	6½	¾	12	¾	2	1½	7/16	1½	1¼	1	1⅞	5	3⅝

† On 1½", 2" and 2½" bore sizes, the head-end (only) pipe thread is not full depth on cylinders with maximum oversize rods. Minimum of three full threads available. ⊖ NPTF ports will be furnished as standard unless SAE straight thread ports are specified.

• Dimension CD is pin diameter. *SAE straight thread ports are indicated by port number.

‡ Straight thread ports. On 1½" bore size an adapter fitting is required on cap end and on head end with maximum oversize rod. (See "Straight Thread Port Adapter" drawing.) Adapters are furnished as standard.

Straight Thread Port Adapters

Used on 1 1/2" bore size only.

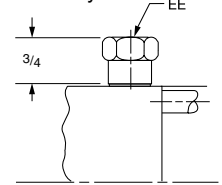

Table 2—Rod Dimensions

Bore	Rod Dia. MM	Thread		Rod Extensions and Pilot Dimensions										Add Stroke		
		Style 2 CC	Style 1 & 3 KK	A	+.000 -.002 B	C	D	NA	V	VA	VB	W	WF	Y	XC	ZC
1½	5/8	1/2-20	7/16-20	¾	1.124	¾	½	9/16	—	¼	3/16	—	1	15/16	5/8	5/8
	1	7/8-14	¾-16	1⅞	1.499	½	7/8	15/16	½	—	—	1	—	25/16	5¾	6¼
2	5/8	1/2-20	7/16-20	¾	1.124	¾	½	9/16	—	¼	3/16	—	1	15/16	5/8	5/8
	1	7/8-14	¾-16	1⅞	1.499	½	7/8	15/16	—	¼	3/8	—	13/8	25/16	5¾	6¼
2½	1⅜	1¼-12	1-14	15/8	1.999	5/8	1⅞	15/16	5/8	—	—	1¼	—	29/16	6	6½
	1¾	1½-12	1¼-12	2	2.374	¾	1½	11/16	¾	—	—	1½	—	23/16	63/8	67/8
3¼	1	7/8-14	¾-16	1⅞	1.499	½	7/8	15/16	—	¼	3/8	—	13/8	27/16	67/8	75/8
	1⅜	1¼-12	1-14	15/8	1.999	5/8	1⅞	15/16	—	¼	1/2	—	15/8	211/16	71/8	77/8
4	1¾	1½-12	1¼-12	2	2.374	¾	1½	11/16	—	¼	9/16	—	17/8	25/16	73/8	81/8
	2	1¾-12	1½-12	2¼	2.624	7/8	11/16	15/16	—	¼	9/16	—	2	31/16	71/2	81/4
5	1	7/8-14	¾-16	1⅞	1.499	½	7/8	15/16	—	¼	3/8	—	13/8	27/16	71/8	77/8
	1⅜	1¼-12	1-14	15/8	1.999	5/8	1⅞	15/16	—	¼	1/2	—	15/8	211/16	73/8	81/8
6	1¾	1½-12	1¼-12	2	2.374	¾	1½	11/16	—	¼	9/16	—	17/8	25/16	75/8	83/8
	2	1¾-12	1½-12	2¼	2.624	7/8	11/16	15/16	—	¼	9/16	—	2	31/16	7¾	8½
6	1⅜	1¼-12	1-14	15/8	1.999	5/8	1⅞	15/16	—	¼	7/16	—	15/8	213/16	81/8	91/8
	1¾	1½-12	1¼-12	2	2.374	¾	1½	11/16	—	¼	9/16	—	17/8	31/16	83/8	93/8
6	2	1¾-12	1½-12	2¼	2.624	7/8	11/16	15/16	—	¼	9/16	—	2	33/16	8½	9½
	2½	2¼-12	17/8-12	3	3.124	1	21/16	23/8	—	¼	11/16	—	2¼	37/16	8¾	9¾

Rod End Dimensions (for Bolted Gland) — See Table 2

See chart on page 3 to determine which bore, rod, and mount combinations have this feature.

Thread Style 1
Small Male

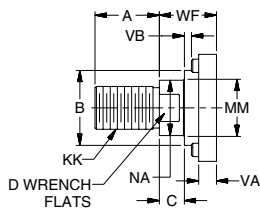

Thread Style 2
Intermediate Male

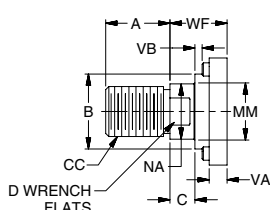

Thread Style 3
Short Female

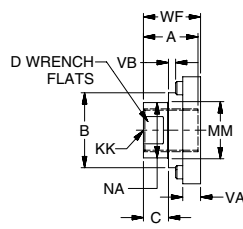

Style 6
Stub End

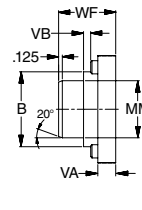

"Special" Thread Style 4

Special thread, extension, rod eye, blank, etc., are also available.

To order, specify "Style 4" and give desired dimensions for KK, A, W or WF. If otherwise special, furnish dimensioned sketch.

A high strength rod end stud is supplied on thread style 1 through 2" diameter rods. Larger sizes or special rod ends are cut threads. Style 1 rod ends are recommended where the workpiece is secured against the rod shoulder. When the workpiece is not shouldered,

style 1 rod ends are recommended through 2" piston rod diameters and style 2 rod ends are recommended on larger diameters. Use style 3 for applications where female rod end threads are required. If rod end is not specified, style 1 will be supplied.

**Tie Rod Extended Mount
Style NM3**

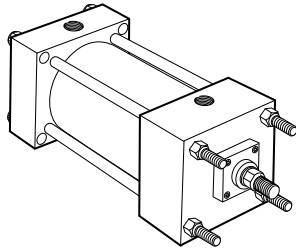

Model NM3 Head Tie Rods Extended, Illustrated. Model NM2 Cap Tie Rods Extended; and Model NM1, Both Ends Tie Rods Extended are also available. All Tie Rod Models can be dimensioned from Model NM3 drawing at right.

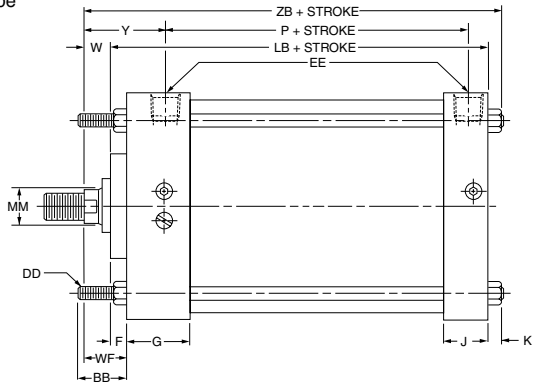
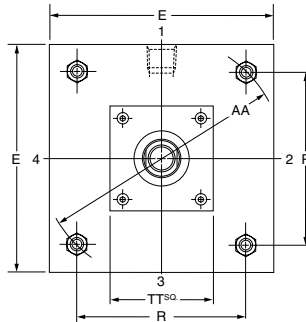

**Head Square Mount
Style REF**

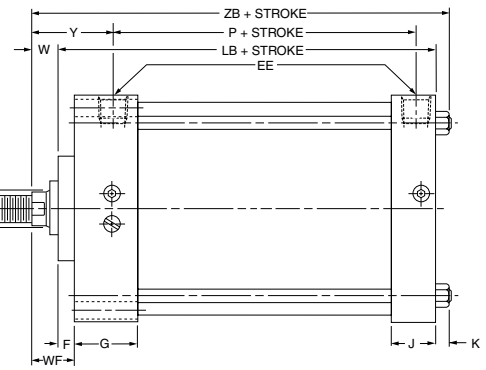
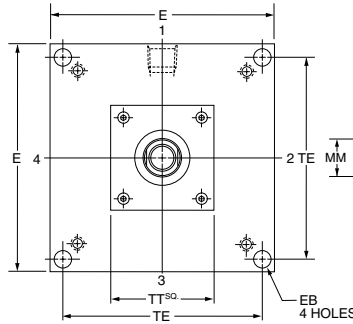
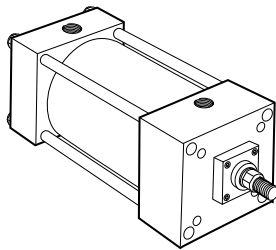

**Cap Square Mount
Style BEF**

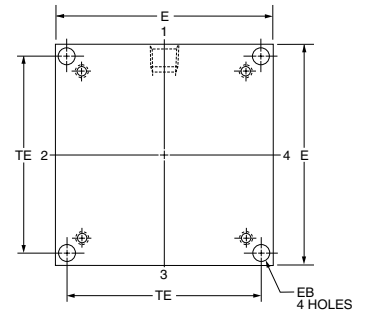
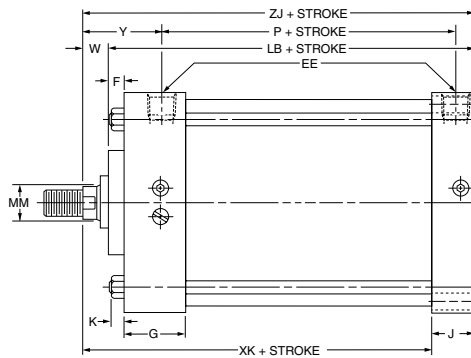
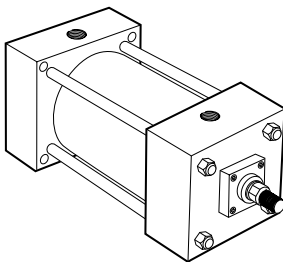

Rod End Dimensions — See Table 2 or 5

Thread Style 1
Small Male

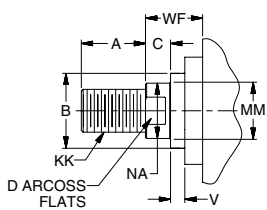

Thread Style 2
Intermediate Male

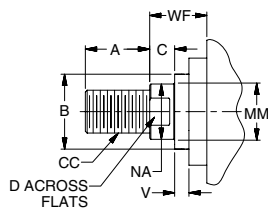

Thread Style 3
Short Female

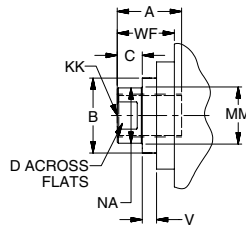

Style 6
Stub End

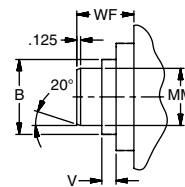

**“Special”
Thread Style 4**

Special thread, extension, rod eye, blank, etc., are also available. To order, specify “Style 4” and give desired dimensions for KK, A, W or WF. If otherwise special, furnish dimensioned sketch.

A high strength rod end stud is supplied on thread style 1 through 2" diameter rods. Larger sizes or special rod ends are cut threads. Style 1 rod ends are recommended where the workpiece is secured against the rod shoulder. When the workpiece is not shouldered,

style 1 rod ends are recommended through 2" piston rod diameters and style 2 rod ends are recommended on larger diameters. Use style 3 for applications where female rod end threads are required. If rod end is not specified, style 1 will be supplied.

Table 1—Envelope and Mounting Dimensions – Style NM3

Bore	AA	BB	DD	E	EE		F	G	J	K	R	Add Stroke	
					NPTF \ominus	SAE*						LB	P
8	9.1	2 ⁵ / ₁₆	5/8-18	8 ¹ / ₂	3/4	12	3/4	2	1 ¹ / ₂	9/16	6.44	5 ⁷ / ₈	3 ¹ / ₄

\ominus NPTF ports will be furnished as standard unless SAE straight thread ports are specified.
*SAE straight thread ports are indicated by port number.

Table 2—Rod Dimensions – Style NM3

Bore	Rod Dia. MM	Thread		Rod Extensions and Pilot Dimensions									Add Stroke	
		Style 2 CC	Style 1 & 3 KK	A	+0.000 -0.002 B	C	D	NA	TT	V	W	WF	Y	ZB
8	1 ³ / ₈	1 ¹ / ₄ -12	1-14	1 ⁵ / ₈	1.999	5/8	1 ¹ / ₈	1 ⁵ / ₁₆	4	1/4	7/8	1 ⁵ / ₈	2 ¹³ / ₁₆	7 ⁵ / ₁₆
	1 ³ / ₄	1 ¹ / ₂ -12	1 ¹ / ₄ -12	2	2.374	3/4	1 ¹ / ₂	1 ¹¹ / ₁₆	4	3/8	1 ¹ / ₈	1 ⁷ / ₈	3 ¹ / ₁₆	7 ⁹ / ₁₆
	2	1 ³ / ₄ -12	1 ¹ / ₂ -12	2 ¹ / ₄	2.624	7/8	1 ¹¹ / ₁₆	1 ¹⁵ / ₁₆	4	3/8	1 ¹ / ₄	2	3 ³ / ₁₆	7 ¹¹ / ₁₆
	2 ¹ / ₂	2 ¹ / ₄ -12	1 ⁷ / ₈ -12	3	3.124	1	2 ¹ / ₁₆	2 ³ / ₈	4	1/2	1 ¹ / ₂	2 ¹ / ₄	3 ⁷ / ₁₆	7 ¹⁵ / ₁₆

Table 3—Envelope and Mounting Dimensions

Table 4—Envelope and Mounting Dimensions – Styles ME3 and ME4

Bore	E	EB	EE		F	G	J	K	TE	Add Stroke	
			NPTF \ominus	SAE*						LB	P
8	8 ¹ / ₂	1 ¹ / ₁₆	3/4	12	3/4	2	1 ¹ / ₂	9/16	7.57	5 ⁷ / ₈	3 ¹ / ₄

\ominus NPTF ports will be furnished as standard unless SAE straight thread ports are specified.
*SAE straight thread ports are indicated by port number.

Table 5—Rod Dimensions – Styles ME3 and ME4

Bore	Rod Dia. MM	Thread		Rod Extensions and Pilot Dimensions									Add Stroke			
		Style 2 CC	Style 1 & 3 KK	A	+0.000 -0.002 B	C	D	NA	TT	V	W	WF	Y	XK	ZB	ZJ
8	1 ³ / ₈	1 ¹ / ₄ -12	1-14	1 ⁵ / ₈	1.999	5/8	1 ¹ / ₈	1 ⁵ / ₁₆	4	1/4	7/8	1 ⁵ / ₈	2 ¹³ / ₁₆	5 ¹ / ₄	7 ⁹ / ₁₆	6 ³ / ₄
	1 ³ / ₄	1 ¹ / ₂ -12	1 ¹ / ₄ -12	2	2.374	3/4	1 ¹ / ₂	1 ¹¹ / ₁₆	4	3/8	1 ¹ / ₈	1 ⁷ / ₈	3 ¹ / ₁₆	5 ¹ / ₂	7 ⁹ / ₁₆	7
	2	1 ³ / ₄ -12	1 ¹ / ₂ -12	2 ¹ / ₄	2.624	7/8	1 ¹¹ / ₁₆	1 ¹⁵ / ₁₆	4	3/8	1 ¹ / ₄	2	3 ³ / ₁₆	5 ⁵ / ₈	7 ¹¹ / ₁₆	7 ¹ / ₈
	2 ¹ / ₂	2 ¹ / ₄ -12	1 ⁷ / ₈ -12	3	3.124	1	2 ¹ / ₁₆	2 ³ / ₈	4	1/2	1 ¹ / ₂	2 ¹ / ₄	3 ⁷ / ₁₆	5 ⁷ / ₈	7 ¹⁵ / ₁₆	7 ³ / ₈

Table 6—Envelope and Mounting Dimensions

**Side Lug Mount
 Style SL**

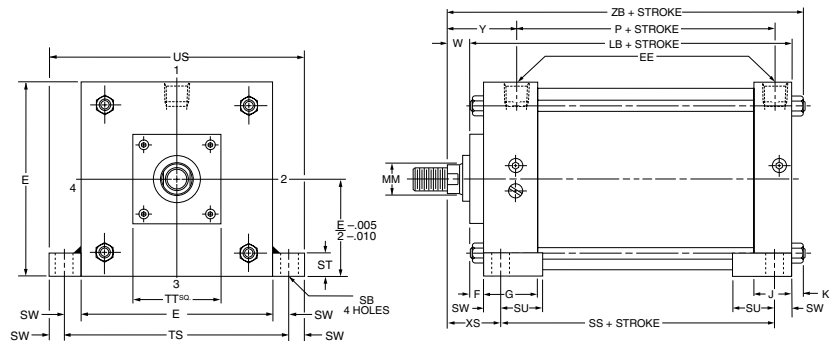
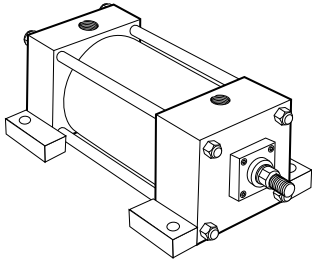

**Side Tap Mount
 Style FS**

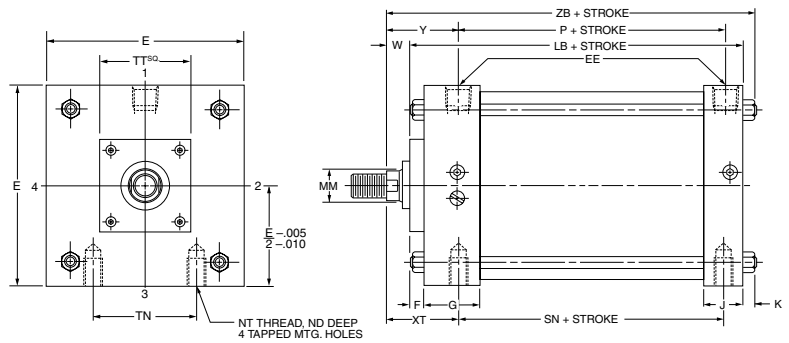
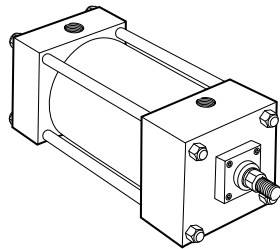

**Cap Fixed Clevis Mount
 Style PB2**

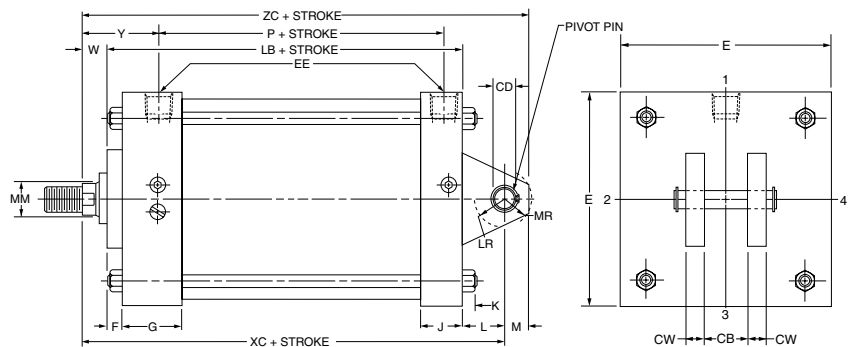
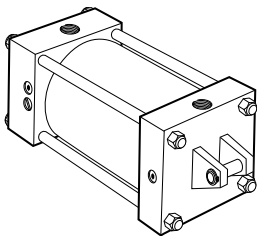

Rod End Dimensions — See Table 2 or 5

**Thread Style 1
 Small Male**

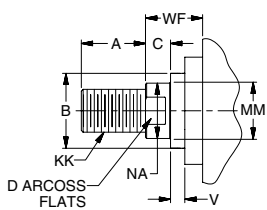

**Thread Style 2
 Intermediate Male**

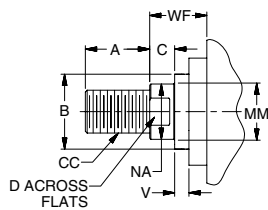

**Thread Style 3
 Short Female**

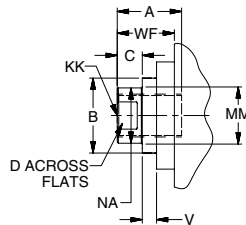

**Style 6
 Stub End**

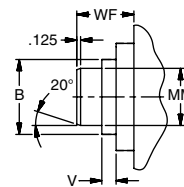

**“Special”
 Thread Style 4**

Special thread, extension, rod eye, blank, etc., are also available. To order, specify “Style 4” and give desired dimensions for KK, A, W or WF. If otherwise special, furnish dimensioned sketch.

A high strength rod end stud is supplied on thread style 1 through 2" diameter rods. Larger sizes or special rod ends are cut threads. Style 1 rod ends are recommended where the workpiece is secured against the rod shoulder. When the workpiece is not shouldered,

style 1 rod ends are recommended through 2" piston rod diameters and style 2 rod ends are recommended on larger diameters. Use style 3 for applications where female rod end threads are required. If rod end is not specified, style 1 will be supplied.

Table 1—Envelope and Mounting Dimensions – Styles SL and FS

Bore	E	EE		F	G	J	K	ND	NT	SB*	ST	SU	SW	TN	TS	US	Add Stroke			
		NPTF \ominus	SAE*														LB	P	SN	SS
8	8 $\frac{1}{2}$	$\frac{3}{4}$	12	$\frac{3}{4}$	2	1 $\frac{1}{2}$	$\frac{9}{16}$	1 $\frac{1}{8}$	$\frac{3}{4}$ -10	$\frac{13}{16}$	1	1 $\frac{9}{16}$	1 $\frac{1}{16}$	4 $\frac{1}{2}$	9 $\frac{7}{8}$	11 $\frac{1}{4}$	5 $\frac{7}{8}$	3 $\frac{1}{4}$	3 $\frac{1}{4}$	3 $\frac{3}{4}$

* Upper surface spotfaced for socket head cap screw.
 \ominus NPTF ports will be furnished as standard unless SAE straight thread ports are specified.
 * SAE straight thread ports are indicated by port number.

Table 2—Rod Dimensions – Styles SL and FS

Bore	Rod Dia. MM	Thread		Rod Extensions and Pilot Dimensions								Add Stroke			
		Style 2 CC	Style 1 & 3 KK	A	+0.000 -0.002 B	C	D	NA	TT	V	W	XS	XT	Y	ZB
8	1 $\frac{3}{8}$	1 $\frac{1}{4}$ -12	1-14	1 $\frac{5}{8}$	1.999	$\frac{5}{8}$	1 $\frac{1}{8}$	1 $\frac{5}{16}$	4	$\frac{1}{4}$	$\frac{7}{8}$	2 $\frac{5}{16}$	2 $\frac{13}{16}$	2 $\frac{13}{16}$	7 $\frac{5}{16}$
	1 $\frac{3}{4}$	1 $\frac{1}{2}$ -12	1 $\frac{1}{4}$ -12	2	2.374	$\frac{3}{4}$	1 $\frac{1}{2}$	1 $\frac{11}{16}$	4	$\frac{3}{8}$	1 $\frac{1}{8}$	2 $\frac{9}{16}$	3 $\frac{1}{16}$	3 $\frac{1}{16}$	7 $\frac{9}{16}$
	2	1 $\frac{3}{4}$ -12	1 $\frac{1}{2}$ -12	2 $\frac{1}{4}$	2.624	$\frac{7}{8}$	1 $\frac{11}{16}$	1 $\frac{15}{16}$	4	$\frac{3}{8}$	1 $\frac{1}{4}$	2 $\frac{11}{16}$	3 $\frac{3}{16}$	3 $\frac{3}{16}$	7 $\frac{11}{16}$
	2 $\frac{1}{2}$	2 $\frac{1}{4}$ -12	1 $\frac{7}{8}$ -12	3	3.124	1	2 $\frac{1}{16}$	2 $\frac{3}{8}$	4	$\frac{1}{2}$	1 $\frac{1}{2}$	2 $\frac{15}{16}$	3 $\frac{7}{16}$	3 $\frac{7}{16}$	7 $\frac{15}{16}$

Table 3—Envelope and Mounting Dimensions

Table 4—Envelope and Mounting Dimensions – Style PB2

Bore	CB	+0.000 CD* -0.001	CW	E	EE		F	G	J	K	L	LR	M	MR	Add Stroke	
					NPTF \ominus	SAE*									LB	P
8	1 $\frac{1}{2}$	1.000	$\frac{3}{4}$	8 $\frac{1}{2}$	$\frac{3}{4}$	12	$\frac{3}{4}$	2	1 $\frac{1}{2}$	$\frac{9}{16}$	1 $\frac{1}{2}$	1 $\frac{1}{4}$	1	1 $\frac{3}{16}$	5 $\frac{7}{8}$	3 $\frac{1}{4}$

* CD is pin diameter.
 \ominus NPTF ports will be furnished as standard unless SAE straight thread ports are specified.
 * SAE straight thread ports are indicated by port number.

Table 5—Rod Dimensions – Style PB2

Bore	Rod Dia. MM	Thread		Rod Extensions and Pilot Dimensions								Add Stroke			
		Style 2 CC	Style 1 & 3 KK	A	+0.000 -0.002 B	C	D	NA	TT	V	W	WF	Y	XC	ZC
8	1 $\frac{3}{8}$	1 $\frac{1}{4}$ -12	1-14	1 $\frac{5}{8}$	1.999	$\frac{5}{8}$	1 $\frac{1}{8}$	1 $\frac{5}{16}$	4	$\frac{1}{4}$	$\frac{7}{8}$	1 $\frac{5}{8}$	2 $\frac{13}{16}$	8 $\frac{1}{4}$	9 $\frac{1}{4}$
	1 $\frac{3}{4}$	1 $\frac{1}{2}$ -12	1 $\frac{1}{4}$ -12	2	2.374	$\frac{3}{4}$	1 $\frac{1}{2}$	1 $\frac{11}{16}$	4	$\frac{3}{8}$	1 $\frac{1}{8}$	1 $\frac{7}{8}$	3 $\frac{1}{16}$	8 $\frac{1}{2}$	9 $\frac{1}{2}$
	2	1 $\frac{3}{4}$ -12	1 $\frac{1}{2}$ -12	2 $\frac{1}{4}$	2.624	$\frac{7}{8}$	1 $\frac{11}{16}$	1 $\frac{15}{16}$	4	$\frac{3}{8}$	1 $\frac{1}{4}$	2	3 $\frac{3}{16}$	8 $\frac{5}{8}$	9 $\frac{5}{8}$
	2 $\frac{1}{2}$	2 $\frac{1}{4}$ -12	1 $\frac{7}{8}$ -12	3	3.124	1	2 $\frac{1}{16}$	2 $\frac{3}{8}$	4	$\frac{1}{2}$	1 $\frac{1}{2}$	2 $\frac{1}{4}$	3 $\frac{7}{16}$	8 $\frac{7}{8}$	9 $\frac{7}{8}$

Table 6—Envelope and Mounting Dimensions

**Head Trunnion Mount
 Style TM1**

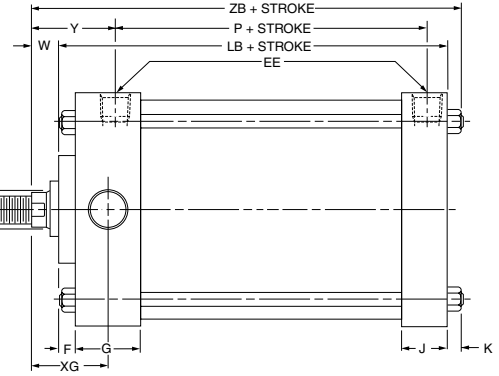
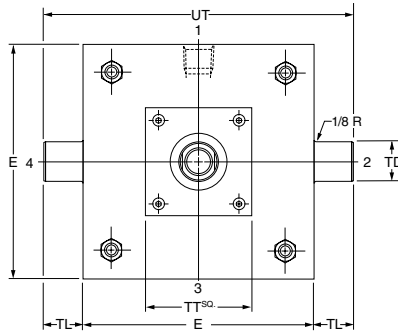
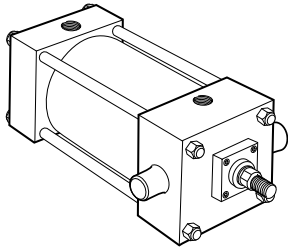

**Cap Trunnion Mount
 Style TM2**

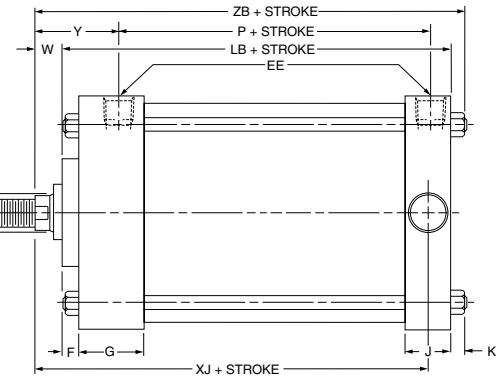
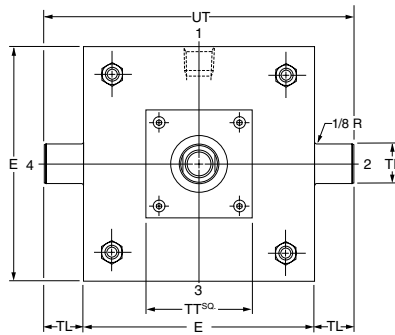
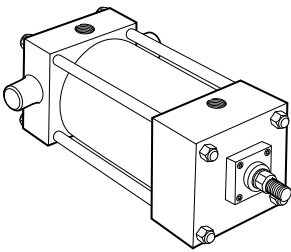

**Intermediate Fixed Trunnion Mount
 Model TM3**

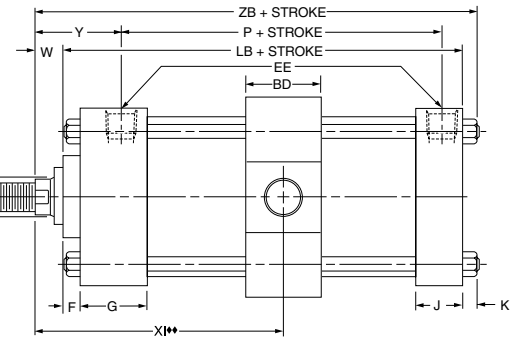
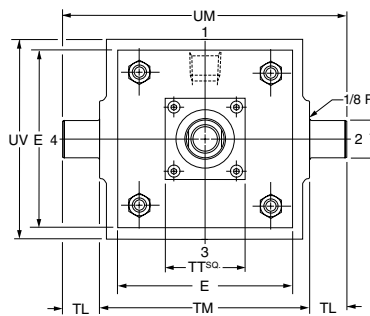
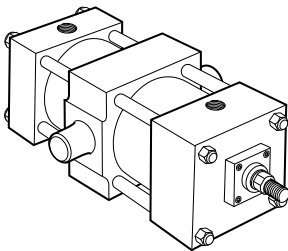

♦♦Dimension XI to be specified by customer.

Rod End Dimensions — See Table 2

**Thread Style 1
 Small Male**

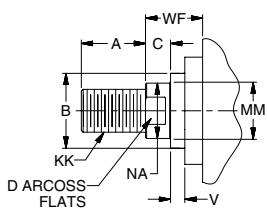

**Thread Style 2
 Intermediate Male**

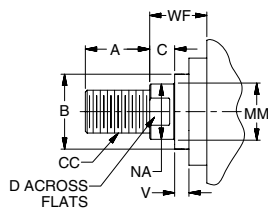

**Thread Style 3
 Short Female**

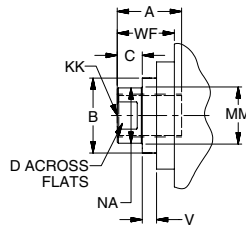

**Style 6
 Stub End**

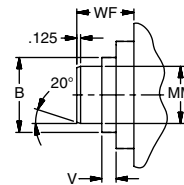

**“Special”
 Thread Style 4**

Special thread, extension, rod eye, blank, etc., are also available. To order, specify “Style 4” and give desired dimensions for KK, A, W or WF. If otherwise special, furnish dimensioned sketch.

A high strength rod end stud is supplied on thread style 1 through 2" diameter rods. Larger sizes or special rod ends are cut threads. Style 1 rod ends are recommended where the workpiece is secured against the rod shoulder. When the workpiece is not shouldered,

style 1 rod ends are recommended through 2" piston rod diameters and style 2 rod ends are recommended on larger diameters. Use style 3 for applications where female rod end threads are required. If rod end is not specified, style 1 will be supplied.

Table 1—Envelope and Mounting Dimensions

Bore	BD	E	EE		F	G	J	K	+.000 TD -.001	TL	TM	UT	UM	UV	Add Stroke	
			NPTF \emptyset	SAE*											LB	P
8	2 $\frac{1}{2}$	8 $\frac{1}{2}$	$\frac{3}{4}$	12	$\frac{3}{4}$	2	1 $\frac{1}{2}$	$\frac{9}{16}$	1.375	1 $\frac{3}{8}$	9 $\frac{3}{4}$	11 $\frac{1}{4}$	12 $\frac{1}{2}$	9 $\frac{1}{2}$	5 $\frac{7}{8}$	3 $\frac{1}{4}$

\emptyset NPTF ports will be furnished as standard unless SAE straight thread ports are specified.

* SAE straight thread ports are indicated by port number.

Table 2—Rod Dimensions

Bore	Rod Dia. MM	Thread		Rod Extensions and Pilot Dimensions								Add Stroke				
		Style 2 CC	Style 1 & 3 KK	A	+.000 -.002 B	C	D	NA	TT	V	W	XG	XI* (Min.)	Y	XJ	ZB
8	1 $\frac{3}{8}$	1 $\frac{1}{4}$ -12	1-14	1 $\frac{5}{8}$	1.999	$\frac{5}{8}$	1 $\frac{1}{8}$	1 $\frac{5}{16}$	4	$\frac{1}{4}$	$\frac{7}{8}$	2 $\frac{5}{8}$	4 $\frac{15}{16}$	2 $\frac{13}{16}$	6	7 $\frac{5}{16}$
	1 $\frac{3}{4}$	1 $\frac{1}{2}$ -12	1 $\frac{1}{4}$ -12	2	2.374	$\frac{3}{4}$	1 $\frac{1}{2}$	1 $\frac{11}{16}$	4	$\frac{3}{8}$	1 $\frac{1}{8}$	2 $\frac{7}{8}$	5 $\frac{3}{16}$	3 $\frac{1}{16}$	6 $\frac{1}{4}$	7 $\frac{9}{16}$
	2	1 $\frac{3}{4}$ -12	1 $\frac{1}{2}$ -12	2 $\frac{1}{4}$	2.624	$\frac{7}{8}$	1 $\frac{11}{16}$	1 $\frac{15}{16}$	4	$\frac{3}{8}$	1 $\frac{1}{4}$	3	5 $\frac{5}{16}$	3 $\frac{3}{16}$	6 $\frac{3}{8}$	7 $\frac{11}{16}$
	2 $\frac{1}{2}$	2 $\frac{1}{4}$ -12	1 $\frac{7}{8}$ -12	3	3.124	1	2 $\frac{1}{16}$	2 $\frac{3}{8}$	4	$\frac{1}{2}$	1 $\frac{1}{2}$	3 $\frac{1}{4}$	5 $\frac{9}{16}$	3 $\frac{7}{16}$	6 $\frac{5}{8}$	7 $\frac{15}{16}$

* Dimension XI to be specified by customer.

Table 3—Envelope and
Mounting Dimensions

Spherical Bearing Mount – Style SA
1½" to 8" Bore Sizes

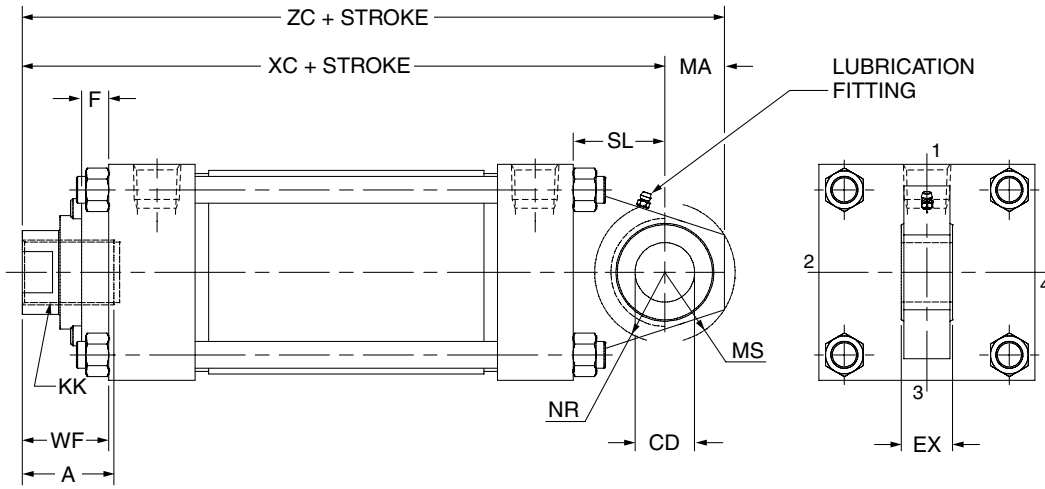

Bore	Rod Dia. MM	Thread**		A	WF	Add Stroke		CD*	EX	MA	MS	NR	Max. Oper. PSI†
		Style 3	KK			XC	ZC						
1½	5/8	7/16-20	3/4	1	5³/₈	6¹/₈	.5000 -0.0005	7/16	3/4	15/16	5/8	1500	
	1	3/4-16	1½	1³/₈	5³/₄	6¹/₂	.5000 -0.0005	7/16	3/4	15/16	5/8	980	
2	5/8	7/16-20	3/4	1	5³/₈	6¹/₈	.5000 -0.0005	7/16	3/4	15/16	5/8	980	
	1	3/4-16	1½	1³/₈	5³/₄	6¹/₂	.5000 -0.0005	7/16	3/4	15/16	5/8	980	
	1³/₈	1-14	1⁵/₈	1⁵/₈	6	6³/₄	.5000 -0.0005	7/16	3/4	15/16	5/8	630	
2½	5/8	7/16-20	3/4	1	5½	6¹/₄	.5000 -0.0005	7/16	3/4	15/16	5/8	630	
	1	3/4-16	1½	1³/₈	5⁷/₈	6⁵/₈	.5000 -0.0005	7/16	3/4	15/16	5/8	630	
	1³/₈	1-14	1⁵/₈	1⁵/₈	6¹/₈	6⁷/₈	.5000 -0.0005	7/16	3/4	15/16	5/8	630	
3¼	1	3/4-16	1½	1³/₈	6⁷/₈	7⁷/₈	.7500 -0.0005	2¹/₃₂	1	1³/₈	1	830	
	1³/₈	1-14	1⁵/₈	1⁵/₈	7¹/₈	8¹/₈	.7500 -0.0005	2¹/₃₂	1	1³/₈	1	830	
	1³/₄	1¼-12	2	1⁷/₈	7³/₈	8³/₈	.7500 -0.0005	2¹/₃₂	1	1³/₈	1	830	
4	2	1½-12	2¼	2	7½	8½	.7500 -0.0005	2¹/₃₂	1	1³/₈	1	550	
	1	3/4-16	1½	1³/₈	6⁷/₈	7⁷/₈	.7500 -0.0005	2¹/₃₂	1	1³/₈	1	550	
	1³/₈	1-14	1⁵/₈	1⁵/₈	7¹/₈	8¹/₈	.7500 -0.0005	2¹/₃₂	1	1³/₈	1	550	
5	1³/₄	1¼-12	2	1⁷/₈	7⁵/₈	8⁵/₈	.7500 -0.0005	2¹/₃₂	1	1³/₈	1	350	
	2	1½-12	2¼	2	7¾	8¾	.7500 -0.0005	2¹/₃₂	1	1³/₈	1	350	
	1³/₈	1-14	1⁵/₈	1⁵/₈	8¹/₈	9³/₈	.7500 -0.0005	2¹/₃₂	1	1³/₈	1	350	
6	1³/₄	1¼-12	2	1⁷/₈	8³/₈	9⁵/₈	1.0000 -0.0005	7/8	1¼	1¹¹/₁₆	1¼	440	
	2	1½-12	2¼	2	8½	9¾	1.0000 -0.0005	7/8	1¼	1¹¹/₁₆	1¼	440	
	2½	1⁷/₈-12	3	2¼	8¾	10	1.0000 -0.0005	7/8	1¼	1¹¹/₁₆	1¼	440	
8	1³/₈	1-14	1⁵/₈	1⁵/₈	8¼	9½	1.0000 -0.0005	7/8	1¼	1¹¹/₁₆	1¼	250	
	1³/₄	1¼-12	2	1⁷/₈	8½	9¾	1.0000 -0.0005	7/8	1¼	1¹¹/₁₆	1¼	250	
	2	1½-12	2¼	2	8⁵/₈	9⁷/₈	1.0000 -0.0005	7/8	1¼	1¹¹/₁₆	1¼	250	
2½	1⁷/₈-12	3	2¼	8⁷/₈	10¹/₈	1.0000 -0.0005	7/8	1¼	1¹¹/₁₆	1¼	250		

† Maximum operating pressure at 4:1 design factor is based on tensile strength of material.

Pressure ratings are based on standard commercial bearing ratings.

Note: For additional dimensions see page 24.

* Dimension CD is hole diameter.

** To match pin diameter in rod eye and cap, when an oversize rod is required, specify rod end style '4', 'KK' thread and 'A' thread length for the standard rod diameter (first rod listed for the bore), and 'W' for the oversize rod. Order the rod eye and clevis bracket for the required bore size from the tables on the spherical bearings accessory page.

Cylinder Accessories
Spherical Bearing Mount – Style SA

Atlas offers a complete range of Cylinder Accessories to assure you of the greatest versatility in present or future cylinder applications. Accessories offered for the

respective cylinder include the Rod Eye, Pivot Pin and Clevis Bracket. To select the proper part number for any desired accessory refer to the charts below.

Spherical Rod Eye

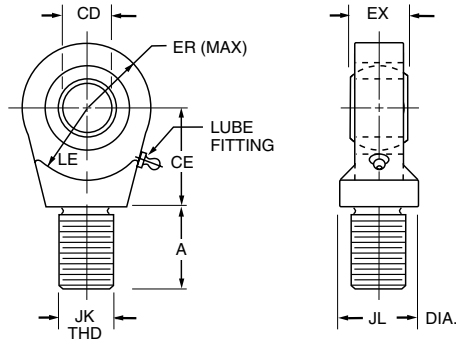

Bore Sizes	1 1/2, 2 & 2 1/2	3 1/4, 4 & 5	6 & 8
Part No.	SB-1	SB-2	SB-3
CD	.5000 ^{-0.0005}	.7500 ^{-0.0005}	1.0000 ^{-0.0005}
A	1 1/16	1	1 1/2
CE	7/8	1 1/4	1 7/8
EX	7/16	2 1/32	7/8
ER	1 3/16	1 1/8	1 1/4
LE	3/4	1 1/16	1 7/16
JK	7/16-20	3/4-16	1-14
JL	7/8	1 5/16	1 1/2
LOAD CAPACITY LBS.	2644	9441	16860

Order to fit Piston Rod Thread Size.

Pivot Pin

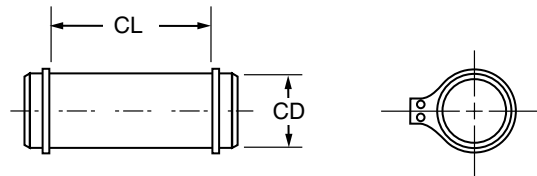

Pivot Pins are furnished with (2) Retainer Rings.

Bore Sizes	1 1/2, 2 & 2 1/2	3 1/4, 4 & 5	6 & 8
Part No.	PP-616	PP-624	PP-632
CD	.4997 ^{-0.0004}	.7497 ^{-0.0005}	.9997 ^{-0.0005}
CL	1 9/16	2 1/32	2 1/2
LOAD CAPACITY LBS.	8600	19300	34300

Clevis Bracket

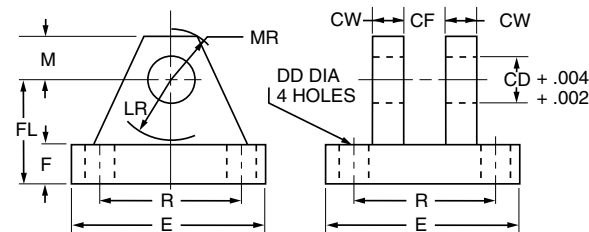

Order to fit Cap or Rod Eye.

Bore Sizes	1 1/2, 2 & 2 1/2	3 1/4, 4 & 5	6 & 8
Part No.	SAB-1	SAB-2	SAB-3
CD	1/2	3/4	1
CF	7/16	2 1/32	7/8
CW	1/2	5/8	3/4
DD	1 3/32	1 7/32	1 7/32
E	3	3 3/4	5 1/2
F	1/2	5/8	3/4
FL	1 1/2	2	2 1/2
LR	1 5/16	1 3/8	1 11/16
M	1/2	7/8	1
MR	5/8	1	1 3/16
R	2.05	2.76	4.10
LOAD CAPACITY LBS.	5770	9450	14300

Part numbers for clevis bracket include pins and keepers.

To determine dimensions for a double rod cylinder, first refer to the desired single rod mounting style cylinder shown on preceding pages of this catalog. After selecting necessary dimensions from that drawing, return to this page and supplement the single rod dimensions with those shown on the drawing and dimension table below. Note that double rod cylinders have a head (Dim. G) at both ends and that dimension LD or LF replaces LB or LG. The double rod dimensions differ from, or are in addition to those for single rod cylinders shown on preceding pages and provide the information needed to completely dimension a double rod cylinder. On a double rod cylinder where the two rod ends are different, be sure to clearly state which rod end is to be assembled at which end.

Port position 1 is standard. If other than standard, specify position 2, 3, or 4 when viewed from one end only.

If only one end of these Double Rod Cylinders is to be cushioned, be sure to specify clearly which end this will be.

Specify XI dimension from rod end #1.

**How to Use Double Rod Cylinder Dimension Drawings
1½" to 6" Bores**

Tie Rod Retained Cartridge

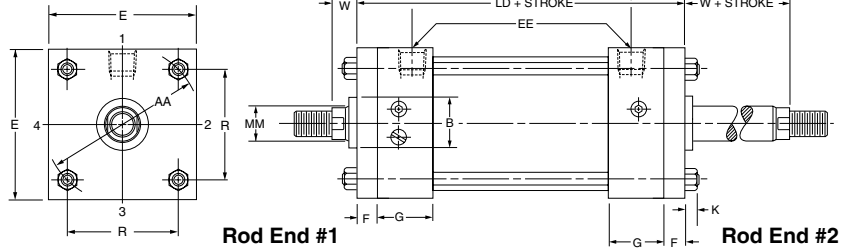

1½" to 6" Bores

Removable Cartridge

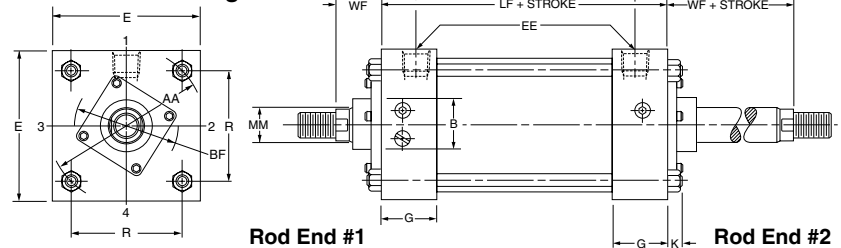

8" Bore

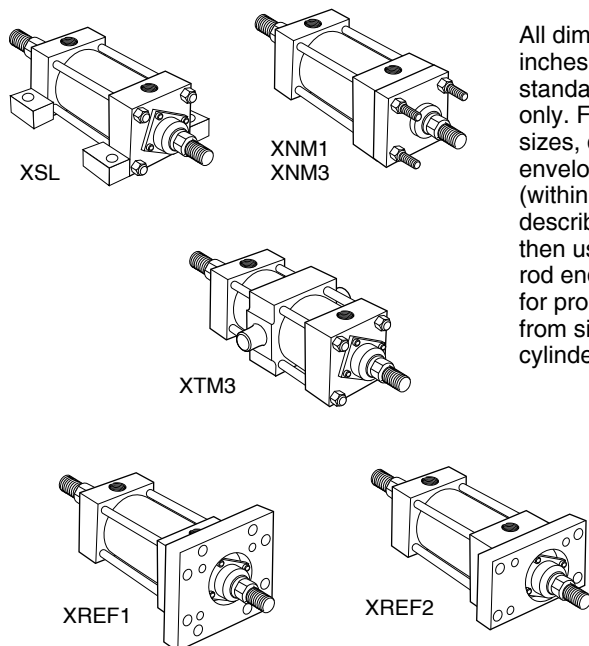
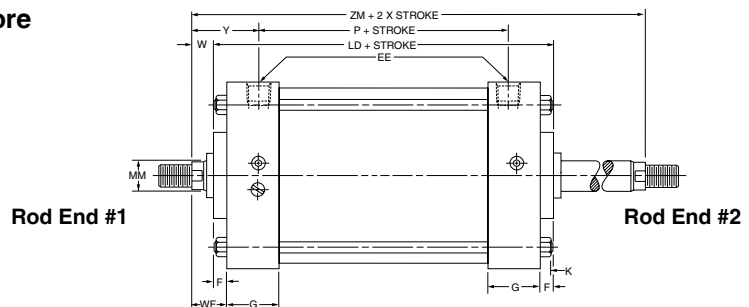

All dimensions are in inches and apply to standard rod sizes only. For alternate rod sizes, determine all envelope dimensions (within LD dim.) as described above and then use appropriate rod end dimensions for proper rod size from single rod cylinder.

Bore	Rod Dia. MM	Add Stroke			Add 2X Stroke
		LD	LF	SS	ZM
1½	5/8	47/8	41/8	33/8	61/8
2	5/8	47/8	41/8	33/8	61/8
2½	5/8	5	4¼	3½	6¼
3¼	1	6	4¾	3¾	7½
4	1	6	4¾	3¾	7½
5	1	6¼	5	35/8	7¾
6	1¾	7	5½	4½	8¾
8	1¾	7½	55/8	4¼	87/8
Replaces:		LB	LG	SS	—
On single rod mounting styles:		All Mtg. Styles		SL	All Mtgs.

NOTES

Cylinder Accessories

Atlas offers a complete range of cylinder accessories to assure you of the greatest versatility in present and future cylinder applications.

Rod End Accessories

Accessories offered for the rod end of the cylinder include Rod Clevis, Eye Bracket, Female Rod Eye, Clevis Bracket, and Pivot Pin. To select the proper part number for any desired accessory, refer to the table below or on the opposite page and look in the row to the right of the rod thread in the first column. For economical accessory selection, it is recommended that rod end style 1 be specified on your cylinder order.

Accessory Load Capacity

The various accessories have been load rated for your convenience. The load Capacity in lbs. Is the recommended maximum load for that accessory based on a 4:1 design factor in tension. (Pivot Pin is rated in shear.) Before specifying, compare the actual load or the tension (pull) force at maximum operating pressure of the cylinder with the load capacity of the accessory you plan to use. If load or pull force of cylinder exceeds load capacity of accessory, consult factory.

Thread Size	Rod Clevis		Eye Bracket		Pivot Pin	
	Part Number	Load Capacity (Lbs.)	Part Number	Load Capacity (Lbs.)	Part Number	Shear Capacity (Lbs.)
7/16-20	JIC-40	2950	EB-195	3375	PP-368A	58900
1/2-20	JIC-41	4000	EB-195	3375	PP-368A	58900
3/4-16	JIC-42A	11200	EB-196	8400	PP-369A	13250
3/4-16	JIC-42	9300	EB-196	8400	PP-369A	13250
7/8-14	JIC-43A	18800	EB-197	13500	PP-370A	23560
7/8-14	JIC-43	12700	EB-197	13500	PP-370A	23560
1-14	JIC-44A	19500	EB-197	13500	PP-370A	23560
1-14	JIC-44	16875	EB-197	13500	PP-370A	23560
1 1/4-12	JIC-45A	33500	EB-198	24700	PP-371A	44550
1 1/4-12	JIC-45	26800	EB-198	24700	PP-371A	44550
1 1/2-12	JIC-46	39500	EB-199	39375	PP-372A	72150
1 3/4-12	JIC-47	54700	EB-200	45000	PP-215A	94250
1 7/8-12	JIC-48	56250	EB-200	45000	PP-215A	94250
2 1/4-12	JIC-49	84375	EB-201	67500	PP-374A	94250
2 1/2-12	JIC-50	84375	EB-202	67500	PP-375A	147250

Rod Clevis Dimensions

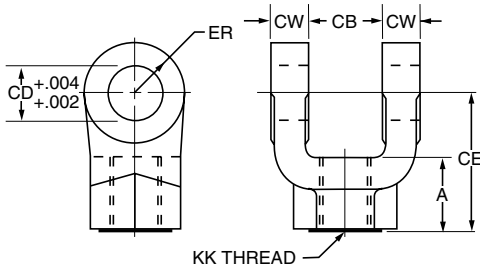

Pivot Pin Dimensions

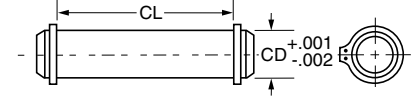

Part Number	A	CB	CD	CE	CW	ER	KK
JIC-40	3/4	3/4	1/2	1 1/2	1/2	1/2	7/16-20
JIC-41	3/4	3/4	1/2	1 1/2	1/2	1/2	1/2-20
JIC-42A	1 1/8	1 1/4	3/4	2 1/8	5/8	3/4	3/4-16
JIC-42	1 1/8	1 1/4	3/4	2 3/8	5/8	3/4	3/4-16
JIC-43A	1 5/8	1 1/2	1	2 15/16	3/4	1	7/8-14
JIC-43	1 5/8	1 1/2	1	3 1/8	3/4	1	7/8-14
JIC-44A	1 5/8	1 1/2	1	2 15/16	3/4	1	1-14
JIC-44	1 5/8	1 1/2	1	3 1/8	3/4	1	1-14
JIC-45A	1 7/8	2	1 3/8	3 3/4	1	1 3/8	1 1/4-12
JIC-45	2	2	1 3/8	4 1/8	1	1 3/8	1 1/4-12
JIC-46	2 1/4	2 1/2	1 3/4	4 1/2	1 1/4	1 3/4	1 1/2-12
JIC-47	3	2 1/2	2	5 1/2	1 1/4	2	1 3/4-12
JIC-48	3	2 1/2	2	5 1/2	1 1/4	2	1 7/8-12
JIC-49	3 1/2	3	2 1/2	6 1/2	1 1/2	2 1/2	2 1/4-12
JIC-50	3 1/2	3	3	6 3/4	1 1/2	2 3/4	2 1/2-12

Part Number	CD	CL
PP-368A	1/2	1 7/8
PP-369A	3/4	2 5/8
PP-370A	1	3 1/8
PP-371A	1 3/8	4 1/8
PP-372A	1 3/4	5 3/16
PP-373A	2	5 3/16
PP-374A	2 1/2	6 3/16
PP-375A	3	6 1/4

1. Pivot Pins are furnished with Clevis Mounted Cylinders as standard.
2. Pivot Pins are furnished with (2) Retainer Rings.

Part numbers for Rod Clevis include pins and keepers.

Eye Bracket Dimensions

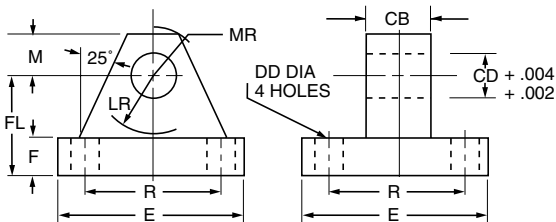

1. When used to mate with the Rod Clevis, select by thread size in table above.
2. When used to mount the Style PB2 Cylinder, select by bore size below.

Part Number	CB	CD	DD	E	F	FL	LR	M	MR	R	Bore
EB-195	3/4	1/2	13/32	2 1/2	3/8	1 1/8	3/4	1/2	9/16	1.63	1 1/2", 2", 2 1/2"
EB-196	1 1/4	3/4	17/32	3 1/2	5/8	1 7/8	1 1/4	3/4	7/8	2.55	3 1/4", 4", 5"
EB-197	1 1/2	1	21/32	4 1/2	3/4	2 1/4	1 1/2	1	1 1/4	3.25	6", 8"
EB-198	2	1 3/8	21/32	5	7/8	3	2 1/8	1 3/8	1 5/8	3.82	-
EB-199	2 1/2	1 3/4	29/32	6 1/2	7/8	3 1/8	2 1/4	1 3/4	2 1/8	4.95	-
EB-200	2 1/2	2	1 1/16	7 1/2	1	3 1/2	2 1/2	2	2 7/16	5.73	-
EB-201	3	2 1/2	1 3/16	8 1/2	1	4	3	2 1/2	3	6.58	-
EB-202	3	3	1 5/16	9 1/2	1	4 1/4	3 1/4	2 3/4	3 1/4	7.50	-

Rod End Accessories

Accessories offered for the rod end of the cylinder include Rod Clevis, Eye Bracket, Female Rod Eye, Clevis Bracket, and Pivot Pin. To select the proper part number for any desired accessory, refer to the table below or on the opposite page and look in the row to the right of the rod thread in the first column. For economical accessory selection, it is recommended that rod end style 1 be specified on your cylinder order.

Accessory Load Capacity

The various accessories have been load rated for your convenience. The load Capacity in lbs. is the recommended maximum load for that accessory based on a 4:1 design factor in tension. (Pivot Pin is rated in shear.) Before specifying, compare the actual load or the tension (pull) force at the maximum operating pressure of the cylinder with the load capacity of the accessory you plan to use. If load or pull force of cylinder exceeds load capacity of accessory, consult factory.

Thread Size	Female Rod Eye		Clevis Bracket		Pivot Pin	
	Part Number	Load Capacity (Lbs.)	Part Number	Load Capacity (Lbs.)	Part Number	Shear Capacity (Lbs.)
7/16-20	REE-89	2950	CB-205	4500	PP-368A	5890
1/2-20	REE-90	3375	CB-205	4500	PP-368A	5890
3/4-16	REE-91	8400	CB-206	8400	PP-369A	13250
7/8-14	REE-92	12700	CB-207	13500	PP-370A	23560
1-14	REE-93	13500	CB-207	13500	PP-370A	23560
1 1/4-12	REE-94	24750	CB-208	24700	PP-371A	44550
1 1/2-12	REE-95	39375	CB-209	39375	PP-372A	72150
1 3/4-12	REE-96	45000	CB-210	54000	PP-215A	94250
1 7/8-12	REE-97	45000	CB-210	54000	PP-215A	94250
2 1/4-12	REE-98	67500	CB-211	67500	PP-374A	147250
2 1/2-12	REE-99	81000	CB-212	124000	PP-375A	212050

Female Rod Eye Dimensions

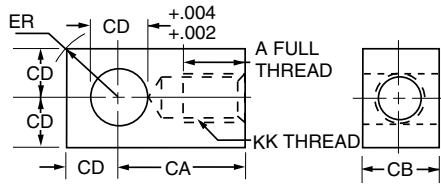

Pivot Pin Dimensions

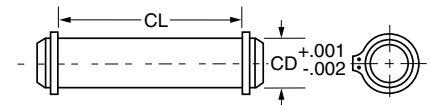

Part Number	A	CA	CB	CD	ER	KK
REE-89	3/4	1 1/2	3/4	1/2	23/32	7/16-20
REE-90	3/4	1 1/2	3/4	1/2	23/32	1/2-20
REE-91	1 1/8	2 1/16	1 1/4	3/4	1 1/16	3/4-16
REE-92	1 1/8	2 3/8	1 1/2	1	1 7/16	7/8-14
REE-93	1 5/8	2 13/16	1 1/2	1	1 7/16	1-14
REE-94	2	3 7/16	2	1 3/8	1 31/32	1 1/4-12
REE-95	2 1/4	4	2 1/2	1 3/4	2 1/2	1 1/2-12
REE-96	2 1/4	4 3/8	2 1/2	2	2 27/32	1 3/4-12
REE-97	3	5	2 1/2	2	2 27/32	1 7/8-12
REE-98	3 1/2	5 13/16	3	2 1/2	3 9/16	2 1/4-12
REE-99	3 1/2	6 1/8	3	3	4 1/4	2 1/2-12

Part Number	CD	CL
PP-368A	1/2	1 7/8
PP-369A	3/4	2 5/8
PP-370A	1	3 1/8
PP-371A	1 3/8	4 1/8
PP-372A	1 3/4	5 3/16
PP-215A	2	5 11/16
PP-374A	2 1/2	6 3/16
PP-375A	3	6 1/4

1. Pivot Pins are furnished with Clevis Mounted Cylinders as standard.
2. Pivot Pins are furnished with (2) Retainer Rings.

Clevis Bracket Dimensions

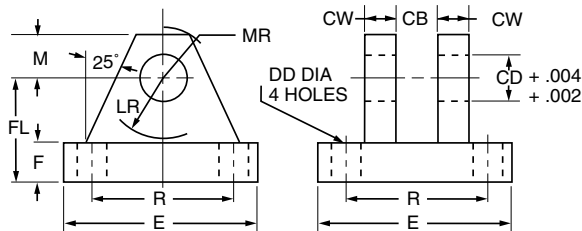

Part Number	CB	CD	CW	DD	E	F	FL	LR	M	MR	R
CB-205	3/4	1/2	1/2	13/32	3 1/2	1/2	1 1/2	3/4	1/2	5/8	2.55
CB-206	1 1/4	3/4	5/8	17/32	5	5/8	1 7/8	1 3/16	3/4	29/32	3.82
CB-207	1 1/2	1	3/4	21/32	6 1/2	3/4	2 1/4	1 1/2	1	1 1/4	4.95
CB-208	2	1 3/8	1	21/32	7 1/2	7/8	3	2	1 3/8	1 21/32	5.73
CB-209	2 1/2	1 3/4	1 1/4	29/32	9 1/2	7/8	3 5/8	2 3/4	1 3/4	2 7/32	7.50
CB-210	2 1/2	2	1 1/2	1 1/16	12 3/4	1	4 1/4	3 3/16	2 1/4	2 25/32	9.40
CB-211	3	2 1/2	1 1/2	1 3/16	12 3/4	1	4 1/2	3 1/2	2 1/2	3 1/8	9.40
CB-212	3	3	1 1/2	1 5/16	12 3/4	1	6	4 1/4	3	3 19/32	9.40

Part numbers for clevis bracket include pins and keepers.

“Style 5” Piston Rod End

Split Couplers and Weld Plates

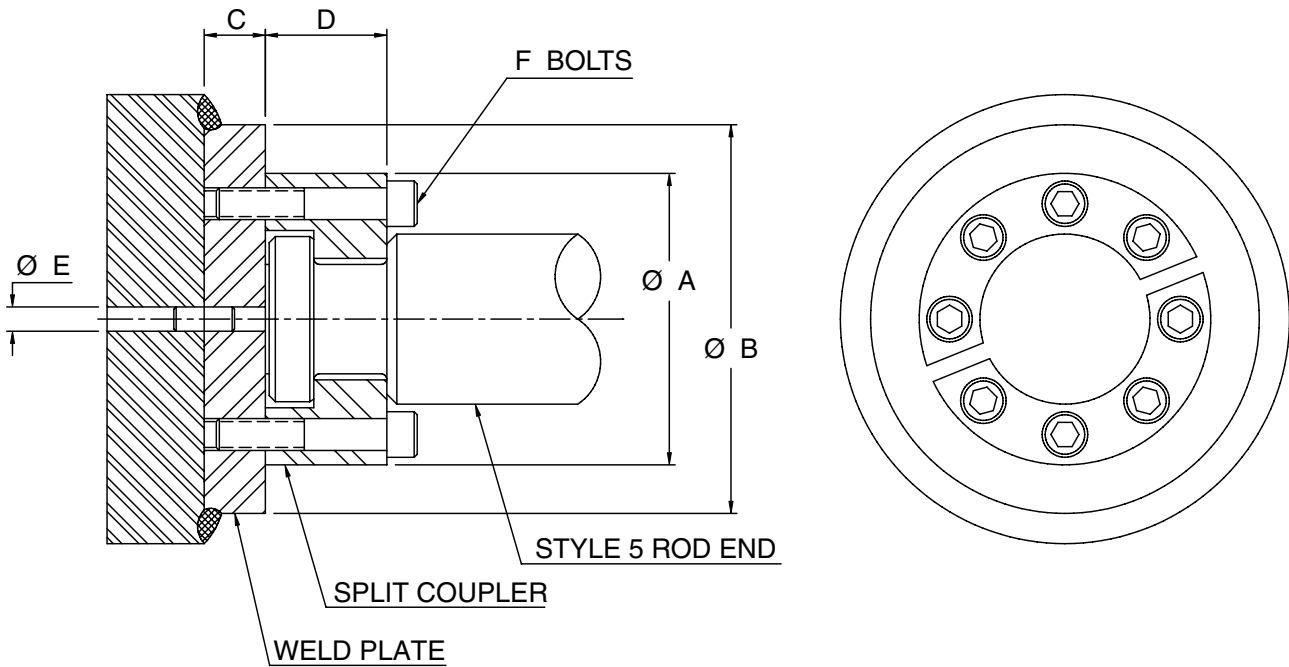

⚠ WARNING: Piston rod separation from the machine member can result in severe personal injury or even death to nearby personnel. The cylinder user must make sure the weld holding the weld plate to the machine is of sufficient quality and size to hold the intended load. The cylinder user must also make sure the bolts holding split coupler to the weld plate are of sufficient strength to hold the intended load and installed in such a way that they will not become loose during the machine's operation.

Table 1 – Part Numbers and Dimensions

ROD DIA.	A	B	C	D	E	F	BOLT SIZE	SPLIT COUPLER PART NO.	WELD PLATE PART NO.
⁵ / ₈	1.50	2.00	.50	.56	.250	4	#10-24 x .94 LG	SC-062	WP-062
1	2.00	2.50	.50	.88	.250	6	.250-20 x 1.25 LG	SC-100	WP-100
1 ³ / ₈	2.50	3.00	.63	1.00	.250	6	.312-18 x 1.50 LG	SC-138	WP-138
1 ³ / ₄	3.00	4.00	.63	1.25	.250	8	.312-18 x 1.75 LG	SC-175	WP-175
2	3.50	4.00	.75	1.63	.375	12	.375-16 x 2.25 LG	SC-200	WP-200
2 ¹ / ₂	4.00	4.50	.75	1.88	.375	12	.375-16 x 2.50 LG	SC-250	WP-250

Note: Screws are not included with split coupler or weld plate.

Atlas “Style 5” Piston Rod End

Split Flange Coupling Rod End

- Simplifies alignment
- Reduces assembly time
- Allows full rated hydraulic pressure in push and pull directions
- Available in 5/8" through 2 1/2" piston rod diameters

Style 5 Rod End

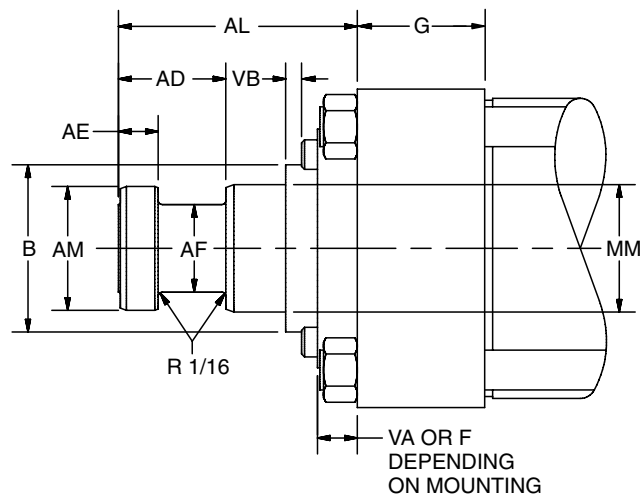

Dimensions Style 5 Rod End

MM Rod Dia.	AD	AE	AF	AM	AL
5/8	5/8	1/4	3/8	.57	1 3/4
1	15/16	3/8	11/16	.95	2 1/2
1 3/8	1 1/16	3/8	7/8	1.32	2 3/4
1 3/4	1 5/16	1/2	1 1/8	1.70	3 1/8
2	1 11/16	5/8	1 3/8	1.95	3 3/4
2 1/2	1 15/16	3/4	1 3/4	2.45	4 1/2

See cylinder dimension pages for B, F, G, VA and VB per bore and rod diameter.

Linear Alignment Couplers are available in 14 standard thread sizes...

Cost Saving Features and Benefits Include...

- Maximum reliability for trouble-free operation, long life and lower operating costs
- Simplifying cylinder installation and reducing assembly costs
- Increased cylinder life by reducing wear on piston and rod bearings
- Increase rod bearing and rod seal life for lower maintenance costs

Alignment Coupler

See Table 1 for Part Numbers and Dimensions

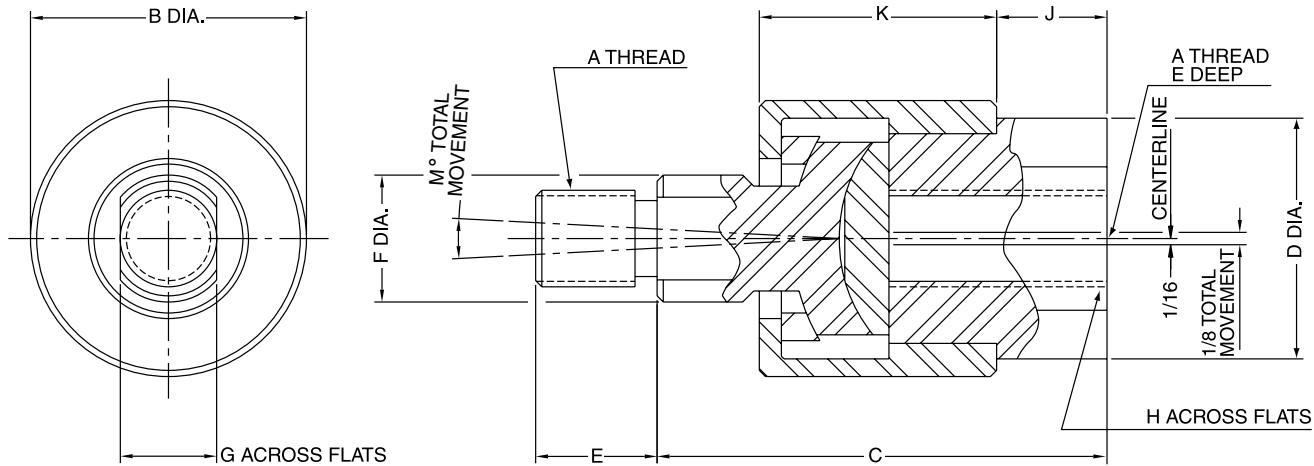

Table 1 – Part Numbers and Dimensions

Part No.	A	B	C	D	E	F	G	H	J	K	M	Max. Pull Load (lbs.)	Approx. Weight (lbs.)
RC-3-5	5/16-24	1 1/8	1 3/4	15/16	1/2	1/2	3/8	3/4	3/8	15/16	6°	1200	.35
RC-3-6	3/8-24	1 1/8	1 3/4	15/16	1/2	1/2	3/8	3/4	3/8	15/16	6°	2425	.35
RC-3-7	7/16-20	1 3/8	2	1 1/8	3/4	5/8	1/2	7/8	3/8	1 3/32	6°	3250	.55
RC-3-8	1/2-20	1 3/8	2	1 1/8	3/4	5/8	1/2	7/8	3/8	1 3/32	6°	4450	.55
RC-3-10	5/8-18	1 3/8	2	1 1/8	3/4	5/8	1/2	7/8	3/8	1 3/32	6°	6800	.55
RC-3-12	3/4-16	2	2 5/16	1 5/8	1 1/8	15/16	3/4	1 5/16	7/16	1 9/32	6°	9050	1.4
RC-3-14	7/8-14	2	2 5/16	1 5/8	1 1/8	15/16	3/4	1 5/16	7/16	1 9/32	6°	14450	1.4
RC-3-16	1-14	3 1/8	3	2 3/8	1 5/8	1 7/16	1 1/4	1 7/8	3/4	1 25/32	6°	19425	4.8
RC-3-20	1 1/4-12	3 1/8	3	2 3/8	1 5/8	1 7/16	1 1/4	1 7/8	3/4	1 25/32	6°	30500	4.8
RC-2-24	1 1/2-12	4	4 3/8	2 1/4	2 1/4	1 3/4	1 1/2	1 15/16	7/8	2 3/4	10°	45750	9.8
RC-2-28	1 3/4-12	4	4 3/8	2 1/4	2 1/4	1 3/4	1 1/2	1 15/16	7/8	2 3/4	10°	58350	9.8
RC-2-30	1 7/8-12	5	5 5/8	3	3	2 1/4	1 15/16	2 5/8	1 3/8	3 3/8	10°	67550	19.8
RC-2-32	2-12	5	5 5/8	3	3	2 1/4	1 15/16	2 5/8	1 3/8	3 3/8	10°	77450	19.8
RC-2-36	2 1/4-12	6 3/4	6 3/8	3 1/4	3 1/2	2 3/4	2 3/8	2 7/8	1 5/8	3 3/4	10°	99250	35.3

How to Order Linear Alignment Couplers — When ordering a cylinder with a threaded male rod end, specify the coupler of equal thread size by part number as listed in Table 1, i.e.; Piston Rod “KK” dimension is 3/4" - 16", specify coupler part number RC-3-12.

Push and Pull Forces
Push Force and Displacement

Cyl. Bore Size (Inches)	Piston Area (Sq. In.)	Cylinder Push Stroke Force In Pounds At Various Pressures									Displacement Per Inch Of Stroke (Gallons)
		25	50	65	80	100	250	500	1000	2000	
1½	1.767	44	88	115	142	177	443	885	1770	3540	.00765
2	3.14	79	157	204	251	314	785	1570	3140	6280	.0136
2½	4.91	123	245	319	393	491	1228	2455	4910	9820	.0213
3¼	8.30	208	415	540	664	830	2075	4150	8300	16600	.0359
4	12.57	314	628	817	1006	1257	3143	6285	12570	25140	.0544
5	19.64	491	982	1277	1571	1964	4910	9820	19640	39280	.0850
6	28.27	707	1414	1838	2262	2827	7068	14135	28270	56540	.1224
8	50.27	1257	2513	3268	4022	5027	12568	25135	50270	100540	.2176

Deductions for Pull Force and Displacement

Piston Rod Dia. (Inches)	Piston Area (Sq. In.)	Piston Rod Diameter Force In Pounds At Various Pressures									Displacement Per Inch Of Stroke (Gallons)
		To determine Cylinder Pull Force or Displacement, deduct the following Force or Displacement corresponding to Rod Size, from selected Push Stroke Force or Displacement corresponding to Bore Size in table above.									
		25	50	65	80	100	250	500	1000	2000	
5/8	.307	8	15	20	25	31	77	154	307	614	.0013
1	.785	20	39	51	65	79	196	392	785	1570	.0034
1⅜	1.49	37	75	97	119	149	373	745	1490	2980	.0065
1¾	2.41	60	121	157	193	241	603	1205	2410	4820	.0104
2	3.14	79	157	204	251	314	785	1570	3140	6280	.0136
2½	4.91	123	245	319	393	491	1228	2455	4910	9820	.0213

General Formula

The cylinder output forces are derived from the formula:

$$F = P \times A$$

Where F = Force in pounds.

P = Pressure at the cylinder in pounds per square inch, gauge.

A = Effective area of cylinder piston in square inches.

Operating Fluids and Temperature Range

Fluidpower cylinders are designed for use with pressurized air, hydraulic oil and fire resistant fluids, in some cases special seals are required.

Class 1 Seals

Class 1 seals are the standard seals provided in a cylinder assembly. They are intended for use with fluids such as: air, nitrogen, mineral base hydraulic oil or MIL-H-5606 within the temperature range of -10°F (-23°C) to +165°F (+74°C). The individual seals may be nitrile (Buna-N), enhanced polyurethane, polymyte, PTFE or filled PTFE.

Class 2 (Nitrile) Seals

Class 2 seals are intended for use with water base fluids within the temperature of -10°F (-23°C) to +165°F (+74°C) except for High Water Content Fluids (HWCF) in which case Class 6 seals should be used. Typical water base fluids compatible with Class 2 seals are: Water, Water-Glycol, Water-in Emulsion, Houghto-Safe 27, 620 5040, Mobil Pyrogard D, Shell Iru 905, Ucon Hydro-lube J-4. Class 2 seals are nitrile. Lipseal will have polymyte or PTFE back-up washer when required. O-rings will have nitrile back-up washers when required.

Class 3 Seals — Ethylene Propylene (E.P.R.) Seals

Class 3 seals are intended for use with some Phosphate Ester Fluids between the temperatures of -10°F (-23°C) to +130°F (+54°C). Typical fluids compatible with Class 3 seals are Skydrol 500 and 700. Class 3 seals are Ethylene Propylene. Lipseals will have a PTFE back-up washer when required. O-rings will have EPR back-up washers when required. **Note:** Class 3 seals are not compatible with mineral base hydraulic oil or greases. Even limited exposure to these fluids will cause severe swelling. PTFE back-up washer may not be suitable when used in a radiation environment.

Class 4 Seals — Nitrile Seals

Class 4 seals are intended for low temperature service with the same type of fluids as used with Class 1 seals within the temperature range of -50°F (-46°C) to +150°F (+66°C). Class 4 seals are nitrile seals. Lipseals will have leather, polymyte or PTFE back-up washers when required. O-rings will have nitrile back-up washers when required. **Note:** Certain fluids may react adversely with Class 4 seals compared to Class 1 seals.

Class 5 Seals — Fluorocarbon Seals

Class 5 seals are intended for elevated temperature service or for some Phosphate Ester Fluids such as Houghto-Safe 1010, 1055, 1120; Fryquel 150, 220, 300, 350; Mobil Pyrogard 42, 43, 53, and 55. **Note:** In addition, Class 5 seals can be used with fluids listed below under Class 1 or Class 2 service. However, they are not compatible with Phosphate Ester Fluids such as Skydrols. Class 5 seals can operate with a temperature range of -10°F (-23°C) to +250°F (+121°C). Fluorocarbon seals may be operated to +400°F (+204°C) with limited service life. For temperatures above +250°F (-121°C) the cylinder must be manufactured with non-studded piston rod thread and a pinned piston to rod connection. Class 5 seals are fluorocarbon seals. Lipseals will have PTFE back-up washers. O-rings will have fluorocarbon back-up when required.

Class 6 Seals

Class 6 seals are intended for High Water Content Fluids (HWCF) such as Houghton Hydrolubric 120B and Sonsol Lubrizol within the temperature range of +40°F (+4°C) to +120°F (+49°C). Class 6 seals are special nitrile compound dynamic seals. Lipseals will have PTFE and or polymyte back-up washers when required. O-rings will have nitrile back-up washers when required. Because of the viscosity of these fluids, cylinders specified with Class 6 seals, will also be modified to have lipseal piston seals and straight cushions.

Lipseal Pistons

Lipseals with a back-up washers are standard in Series L cylinders and are often used for hydraulic applications when virtually zero static leakage is required. Lipseals will function properly in these applications when used in conjunction with moderate hydraulic pressures.

Warning!

The piston rod stud and the piston rod to piston threaded connections are secured with an anaerobic adhesive which is temperature sensitive. Cylinders specified with fluorocarbon seals are assembled with anaerobic adhesive having a maximum temperature rating of +250°F (+121°C). Cylinders specified with all other seal compounds are assembled with anaerobic adhesive have a maximum operating temperature rating +165°F (+74°C). These temperature limitations are necessary to prevent the possible loosening of the threaded connections. Cylinders originally manufactured with Class 1 seals (Nitrile) that will be exposed to ambient temperatures above +165°F (+74°C) must be modified for higher temperature service. Contact the factory immediately and arrange for the piston to rod and the stud to piston rod connections to be properly reassembled to withstand the higher temperature service.

Low Friction Hydraulic Seals

Low Friction hydraulic seals are available as an option for both piston and piston rod seals for Series L cylinders. They are sometimes used when a cylinder is controlled by servo or proportional valve. The seal assembly itself is a two piece assembly consisting of a filled PTFE dynamic seal with an elastomer expander. A piston seal assembly consists of one seal assembly in the middle of the piston with a filled PTFE wear ring on each side of the piston. The piston rod seal assembly consists of two seal assemblies and an elastomer wiper seal. The filled PTFE seals are compatible with Class 1, 2, 3, 4 & 5 fluids and provide virtually leak free sealing. The expanders and rod wiper will be nitrile unless Class 3 or 5 seals are specified. In those cases the expanders and wiper will be EPR and fluorocarbon respectively. When specifying low friction seals specify if piston, piston rod seals or both are required. **Note:** It may be necessary to cycle these seals 40 or 50 times before achieving leakage free performance.

Cast Iron Piston Rings

Cast iron rings are optional piston seals for Series L cylinders. They offer the widest operating conditions by tolerating high operating pressures, wide temperature range and are compatible with most fluids. The only drawback of cast iron rings is that they allow a small amount of leakage. The leakage for a 4" bore cylinder, operating at 2000 psi, with mineral base hydraulic fluid will be less than 10in.³/min. Leakage will increase as pressure, bore size and viscosity of the operating hydraulic fluid increases. For these reasons cast iron rings are not recommended when using water or Class 6 fluids.

Water Service

Series L hydraulic cylinders can be modified for water operation and supplied with chrome-plated cylinder bore; electroless nickel-plated head, cap and piston; chrome-plated precipitation hardened stainless steel piston rod, chrome-plated cushion plungers. When high water base fluids are the operating medium, hydraulic cylinders are usually supplied with high water base rod wiper and seals. Water and high water base fluid operated cylinders are best used on short stroke applications or where high pressure is applied only to clamp the load.

Warranty

Atlas will warrant cylinders modified for water or high water content fluid service to be free of defects in materials or workmanship, but cannot accept responsibility to premature failure due to excessive wear due to lack of lubricity or where failure is caused by corrosion, electrolysis or mineral deposits within the cylinder.

Class No.	Typical Fluids	Temperature Range
1 Standard Nitrile Polyurethane	Air, Nitrogen Hydraulic Oil, Mil-H-5606 Oil	-10°F (-23°C) to +165°F (+74°C)
2 Optional Water base fluid seal	Water, Water-Glycol, HWCF — See Class 6 below. Water-in-Oil Emulsion Houghto-Safe, 271, 620, 5040 Mobil Pyrogard D, Shell Iru 905 Ucon Hydrolube J-4	-10°F (-23°C) to +165°F (+74°C)
3 Special (EPR) (At extra cost) Note: Class 3 seals are not compatible with hydraulic oil.	Some Phosphate Ester Fluids Skydrol 500, 7000	-10°F (-23°C) to +130°F (+54°C)
4 Special (Nitrile) (At extra cost)	Low Temperature Air or Hydraulic Oil	-50°F (-46°C) to +150°F (+66°C)
5 Optional (At extra cost) (Fluorocarbon Seals) Note: Class 5 seals are not suitable for use with Skydrol fluid, but can be used with hydraulic oil if desired	High Temperature Houghto-Safe 1010, 1055, 1120 Fryquel 150, 220, 300, 550 Mobil Pyrogard 42,43,53,55	See above paragraph on Fluorocarbon seals for recommended temperature range.
6 Optional (HWCF) (At extra cost)	Houghton, Hydrolubric 120B Sonsol Lubrizol, for other HWCF — consult factory.	+40°F (+4°C) to +120°F (+49°C)

Application Data

The proper application of a fluid power cylinder requires consideration of the operating pressure, the fluid medium, the mounting style, the length of stroke, the type of piston rod connection to the load, thrust or tension loading on the

rod, mounting attitude, the speed of stroke, and how the load in motion will be stopped. Information given here provides pressure rating data for pneumatic and hydraulic cylinders.

Hydraulic Cylinders (Medium-Duty)

Pressure ratings for Series L hydraulic cylinders vary by bore size and rod size as shown in table below.

For pressures higher than those indicated, Series H heavy-duty cylinders should be used.

**Series L Hydraulic Cylinders
Maximum Pressure Rating**

Bore Size (Inches)	Rod Diameters (Inches)	Pressure Rating At 4:1 Design* Factor (On Tensile)
1 1/2	5/8	2000
	1	2300
2	5/8	1100
	1	2000
	1 3/8	2000
2 1/2	5/8	700
	1	1400
	1 3/8	1400
	1 3/4	1400
3 1/4	1	1300
	1 3/8	1300
	1 3/4	1300
	2	1300
4	1	900
	1 3/8	900
	1 3/4	900
	2	900

Bore Size (Inches)	Rod Diameters (Inches)	Pressure Rating At 4:1 Design* Factor (On Tensile)
5	1	600
	1 3/8	950
	1 3/4	950
6	2	950
	1 3/8	700
	1 3/4	700
	2 1/2	700
8	2 1/2	700
	1 3/8	400
	1 3/4	650
	2	650

*Applies to all mountings except Style REF2. See page 10.

Oversize Ports

Oversize NPTF ports can be provided, at an extra charge. For ports one size larger than standard, welded port bosses which protrude from the side of the head or cap are supplied. For dimensions, see drawing below and table.

Oversize NPTF Port Boss Dimensions

Bore	EE (NPTF)	A (Dia.)	B	C	D	P
1 1/2	1/2	1 1/8	15/16	9/16	1/2	2 3/16
2	1/2	1 1/8	15/16	9/16	1/2	2 3/16
2 1/2	1/2	1 1/8	15/16	9/16	1/2	2 5/16
3 1/4	3/4	1 3/8	1	11/16	5/8	2 9/16
4	3/4	1 3/8	1	11/16	5/8	2 9/16
5	3/4	1 3/8	1	11/16	5/8	2 13/16
6	1	1 3/4	1 3/16	15/16	3/4	3 3/16
8	1	1 3/4	1 3/16	15/16	3/4	3 5/16

Oversize SAE Straight Thread Port Boss Dimensions

Bore	EE (SAE)	A (Dia.)	B	C	D	P
1 1/2	8	1 1/8	15/16	9/16	1/2	2 3/16
2	8	1 1/8	15/16	9/16	1/2	2 3/16
2 1/2	8	1 1/8	15/16	9/16	1/2	2 5/16
3 1/4	10	1 3/8	1	11/16	5/8	2 9/16
4	10	1 3/8	1	11/16	5/8	2 9/16
5	10	1 3/8	1	11/16	5/8	2 13/16
6	16†	1 3/4	1 3/16	15/16	3/4	3 3/16
8	16†	1 3/4	1 3/16	15/16	3/4	3 5/16

†Available at head end only. For cap end, consult factory.

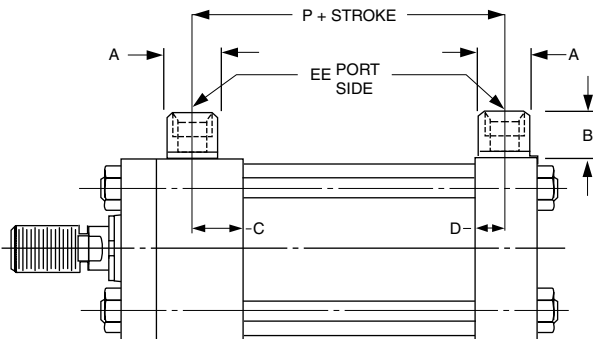

Ports

Atlas Series L hydraulic cylinders are supplied with NPTF pipe thread ports. If specified on your order, extra ports can be provided on the sides of heads or caps that are not occupied by mountings or cushion valve.

Standard port location is position 1 as shown on line drawings in product catalog and Figure 1 below. Cushion adjustment needle and check valves are at position 2 (or 3), depending on mounting style. Heads or caps which do not have an integral mounting can be rotated and assembled with ports at 90° or 180° from standard position. Mounting styles on which head or cap can be rotated at no extra charge are shown in Table A below. To order, specify by position number. In such assemblies the cushion adjustment needle and check valve rotate accordingly since their relationship with port position does not change.

Figure 1

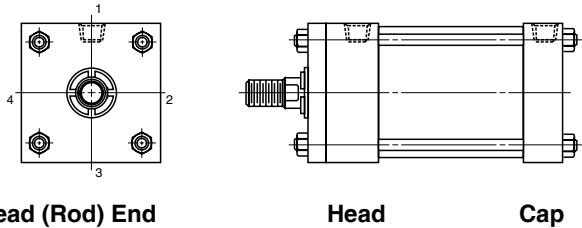

Table A

Model	Port Position Available	
	Head End	Cap End
NM1, NM2, NM3, REF2, BEF2, REF, BEF, REF1, BEF1, TM3	1, 2, 3 or 4	1, 2, 3 or 4
TM2, PB2, SB	1, 2, 3 or 4	1 or 3
TM1	1 or 3	1, 2, 3 or 4
SL, FS	1	1

Ports can be supplied at positions other than those shown in Table A at an extra charge. To order, specify port position as shown in Figure 1.

Table B

SAE Straight Thread O-Ring Ports

Size No.	Tube O.D. (In.)	Thread Size	Size No.	Tube O.D. (In.)	Thread Size
2	1/8	5/16 - 24	6	3/8	9/16 - 18
3	3/16	3/8 - 24	8	1/2	3/4 - 16
4	1/4	7/16 - 20	10	5/8	7/8 - 14
5	5/16	1/2 - 20	12	3/4	1 1/16 - 12

Note: For the pressure ratings of individual connectors, contact your connector supplier. Hydraulic cylinders applied with meter out or deceleration circuits are subject to intensified pressure at the cylinder piston rod end. The rod end pressure is approximately equal to:

$$\frac{\text{Effective Cap End Piston Area}}{\text{Effective Rod End Piston Area}} \times \text{Operating Pressure}$$

International Ports

Other port configurations to meet international requirements are available at extra cost. Atlas Series L cylinders can be supplied, on request, with British standard taper port (BSPT). Such port has a taper of 1 in 16 measured on the diameter (1/16" per inch). The thread form is Whitworth System, and size and number of threads per inch are as follows:

Table C

British Standard Pipe Threads

Nominal Pipe Size	No. Threads Per Inch	Pipe O.D.
1/8	28	.383
1/4	19	.518
3/8	19	.656
1/2	14	.825
3/4	14	1.041

British standard parallel internal threads are designated as BSPP and have the same thread form and number of threads per inch as the BSPT type and can be supplied, on request, at extra cost. Unless otherwise specified, the BSPP or BSPT port size supplied will be the same nominal pipe size as the NPTF port for a given bore size cylinder.

Metric ports can also be supplied to order at extra cost. Consult factory.

Stroke Data

Atlas cylinders are available in any practical stroke length. The following information should prove helpful to you in selecting the proper stroke for your cylinder application.

Stroke Tolerances Stroke length tolerances are required due to buildup of tolerances of piston, head, cap and cylinder body. Standard production stroke tolerances run $+1/32"$ to $-1/64"$ up to 20" stroke, $+1/32"$ to $-.20"$ for 21" to 60" and $+1/32"$ to $-1/32"$ for greater than 60" stroke. For closer tolerances on stroke length, it is necessary to specify the required tolerance plus the operating pressure and temperature at which the cylinder will operate. Stroke tolerances smaller than .015" are not generally practical due to elasticity of cylinders. If machine design requires such close tolerances, use of a stroke adjuster (below) may achieve the desired result.

Tie Rod Supports

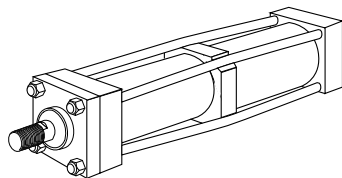

Rigidity of Envelope The prestressed tie rod construction of cylinders has advantages in rigidity within the limits of the cylinder tube to resist buckling. For long stroke cylinders within practical limits. Tie rod supports (see table below) which move the tie rod centerlines radially outward are used.

Standard tie rod supports are kept within the envelope dimensions of the head and cap, and generally do not interfere with mounting a long cylinder.

Number of Supports Required	Stroke (Inches)												
	Bore	36	48	60	72	84	96	108	120	132	144	156	168
1 1/2	—	—	1	1	1	2	2	2	3	3	3	4	
2	—	—	—	1	1	1	1	2	2	2	2	3	
2 1/2	—	—	—	—	—	1	1	1	1	1	2	2	
3 1/4	—	—	—	—	—	—	—	1	1	1	1	1	
4	—	—	—	—	—	—	—	—	—	1	1	1	

Note: 5" through 8" bore sizes — no supports required.

Stroke Adjusters

Stroke Adjusters For the requirement where adjusting the stroke is specified. Atlas has several designs to offer, one of which is illustrated below. This is suitable for infrequent* adjustment and is economical.

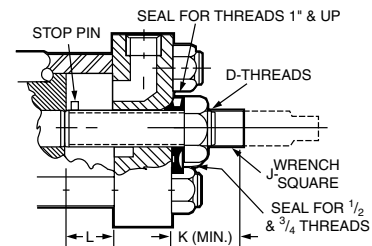

Here a "retracting stroke adjuster" must be called for in specifications, and the length of the adjustment must be specified.

Where frequent adjustment or cushions at the cap end are required, other designs are available according to application needs.

Bore Size	D	J	K	L (Max.)
1 1/2, 2	1/2 - 20	5/16	15/16	5
2 1/2, 3 1/4, 4	3/4 - 16	7/16	1 1/4	8
5, 6	1 - 14	5/8	1 11/16	9
8	1 1/2 - 12	15/16	2 1/8	18

* Infrequent is defined by positioning the retract stroke in a couple of attempts at original machine set-up. The frequent stroke adjuster is recommended when adjustments may be required by the end user.

Thrust Key Mountings

Thrust key mountings eliminate the need of using fitted bolts or external keys on side mounted cylinders. Mounting styles SL and FS can be provided with the gland retainer plate extended below the mounting side of the cylinder (see illustration below). This extended retainer plate can then be fitted into a keyway milled into the mounting surface of the machine member.

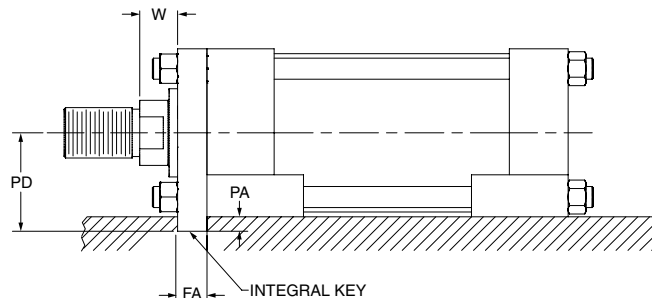

Bore	Dim. FA	Dim. PA	Dim. PD Mtg. Styles SL, FS
1 1/2	.312 +.000 -.002	3/16	1 3/16
2			1 7/16
2 1/2			1 11/16
3 1/4	.562 +.000 -.002	5/16	2 3/16
4			2 9/16
5			3 1/16
6	.687 +.000 -.002	3/8	3 5/8

Cylinder Weights

The weights shown in Table A are for Atlas Series L cylinders with various piston rod diameters. To determine the net weight of a cylinder, first select the proper basic weight for zero stroke, then calculate the weight of the cylinder stroke and add the result to the basic weight. For extra rod extension, use piston rod weights per

inch shown in Table B. Weights of cylinders with intermediate rods may be estimated from table below by taking the difference between the piston rod weights per inch and adding it to the standard rod diameter weight for the cylinder bore size involved.

Table A Cylinder Weights, in pounds, for Series L cylinders

Bore Size	Rod Dia.	Single Rod Cylinders Basic Wt. Zero Stroke		Add Per Inch of Stroke	Double Rod Cylinders Basic Wt. Zero Stroke		Add Per Inch of Stroke
		NM1, NM2, NM3, REF2, BEF2, REF, BEF, FS	REF1, BEF1, SL, TM1, TM2, PB2, TM3, SA		XNM1, XNM3, XREF2, XFS	XREF2, XSL, XTM1, XTM3	
1 1/2"	5/8"	3.7	4.3	.3	4.2	4.8	.6
	1"	4.5	5.1	.4	5.8	6.7	.8
2"	5/8"	6.5	6.9	.5	8.2	8.6	1.0
	1"	7.0	7.5	.63	9.0	9.5	1.3
	1 3/8"	8.5	8.9	.8	11.2	11.6	1.6
2 1/2"	5/8"	9.0	9.7	.6	11.4	12.1	1.2
	1"	9.5	10.0	.73	12.0	12.5	1.5
	1 3/4"	13.2	13.6	1.1	19.8	20.5	2.2
3 1/4"	1"	16.5	17.5	.8	22.0	23.0	1.6
	1 3/8"	17.0	18.0	1.0	22.5	23.5	2.0
	2"	27.0	28.0	1.4	43.0	44.0	2.8
4"	1"	26.0	31.0	1.0	33.0	38.0	2.0
	1 3/8"	26.5	31.5	1.2	33.5	38.5	2.5
	2 1/2"	36.0	42.0	2.0	53.0	58.0	4.0
5"	1"	39.0	46.0	1.1	48.0	55.0	2.2
	1 3/8"	39.5	46.5	1.3	48.5	55.5	2.6
	2"	40.0	57.0	1.7	59.0	66.0	3.4
6"	1 3/8"	68.0	77.0	1.5	80.0	89.0	3.0
	2 1/2"	78.0	87.0	2.3	88.0	107.0	4.5
8"	1 3/8"	94.0	99.0	2.0	108.0	113.0	4.0
	2 1/2"	104.0	109.0	2.8	126.0	131.0	5.5

Table B

Rod Dia.	Piston Rod Wt. Per Inch	Rod Dia.	Piston Rod Wt. Per Inch
5/8"	.09	1 3/4"	.68
1"	.22	2"	.89
1 3/8"	.42	2 1/2"	1.40

Stop Tubing

Stop tube is recommended to lengthen the distance between the bushing and piston to reduce bearing loads when the cylinder is fully extended. This is especially true of horizontally mounted and long stroke cylinders. Long stroke cylinders achieve additional stability through the use of a stop tube.

When specifying cylinders with long stroke and stop tube, be sure to call out the net stroke and the length of the stop tube. Machine design can be continued without delay by laying in a cylinder equivalent in length to the NET STROKE PLUS STOP TUBE LENGTH, which is referred to as GROSS STROKE.

Drawing A

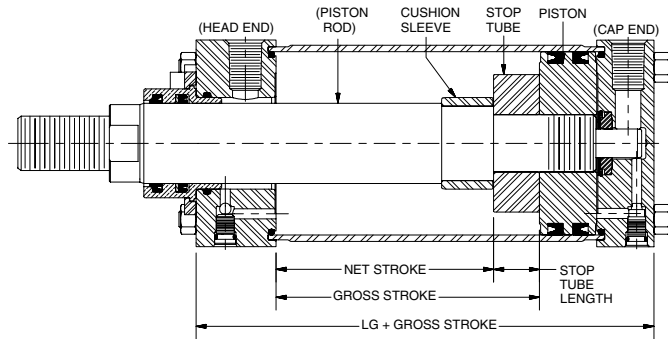

This design is supplied on hydraulic cylinders with cushion head end or both ends.

Drawing B

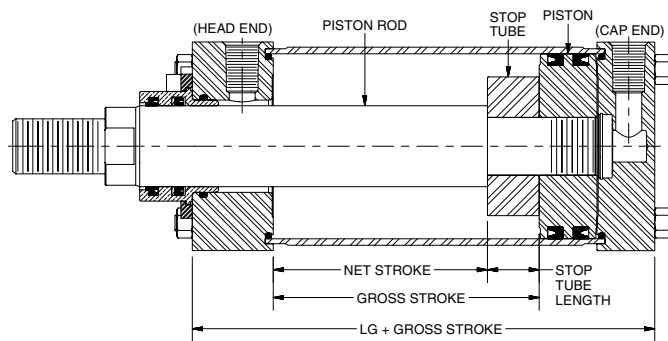

This design is supplied on all non-cushion cylinders.

Mounting Classes

Standard mountings for fluid power cylinders fall into three basic groups. The groups can be summarized as follows:

Group 1 Straight Line Force Transfer with fixed mounts which absorb force on cylinder centerline.

Group 2 Pivot Force Transfer. Pivot mountings permit a cylinder to change its alignment in one plane.

Group 3 Straight Line Force Transfer with fixed mounts which do not absorb force on cylinder centerline.

Because a cylinder's mounting directly affects the maximum pressure at which the cylinder can be used, the chart below should be helpful in selection of the proper mounting combination for your application. Stroke length, piston rod connection to load, extra piston rod length over standard, etc., should be considered for thrust loads. Alloy steel mounting bolts are recommended for all mounting styles, and thrust keys are recommended for Group 3.

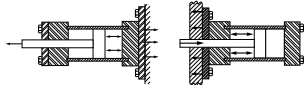
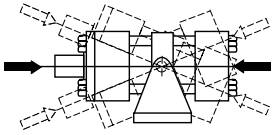
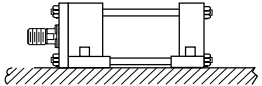
Group 1 FIXED MOUNTS which absorb force on cylinder centerline.	
<p>Heavy-Duty Service For Thrust Loads For Tension Loads</p>	 <p>Style NM2 Style NM3</p>
<p>Medium-Duty Service For Thrust Loads For Tension Loads</p>	<p>Styles BEF1, BEF2 Styles REF1, REF2</p>
<p>Light-Duty Service For Thrust Loads For Tension Loads</p>	<p>Style BEF2 Style REF2</p>
Group 2 PIVOT MOUNTS which absorb force on cylinder centerline.	
<p>Heavy-Duty Service For Thrust Loads For Tension Loads</p>	 <p>Styles TM1, TM3 Styles TM1, TM2, PB2, TM3</p>
<p>Medium-Duty Service For Thrust Loads For Tension Loads</p>	<p>Style PB2 Style PB2</p>
Group 3 FIXED MOUNTS which do not absorb force on the centerline.	
<p>Heavy-Duty Service For Thrust Loads For Tension Loads</p>	 <p>Style SL Style SL</p>
<p>Medium-Duty Service For Thrust Loads For Tension Loads</p>	<p>Style FS Style FS</p>

Piston Rod — Stroke Selection Chart

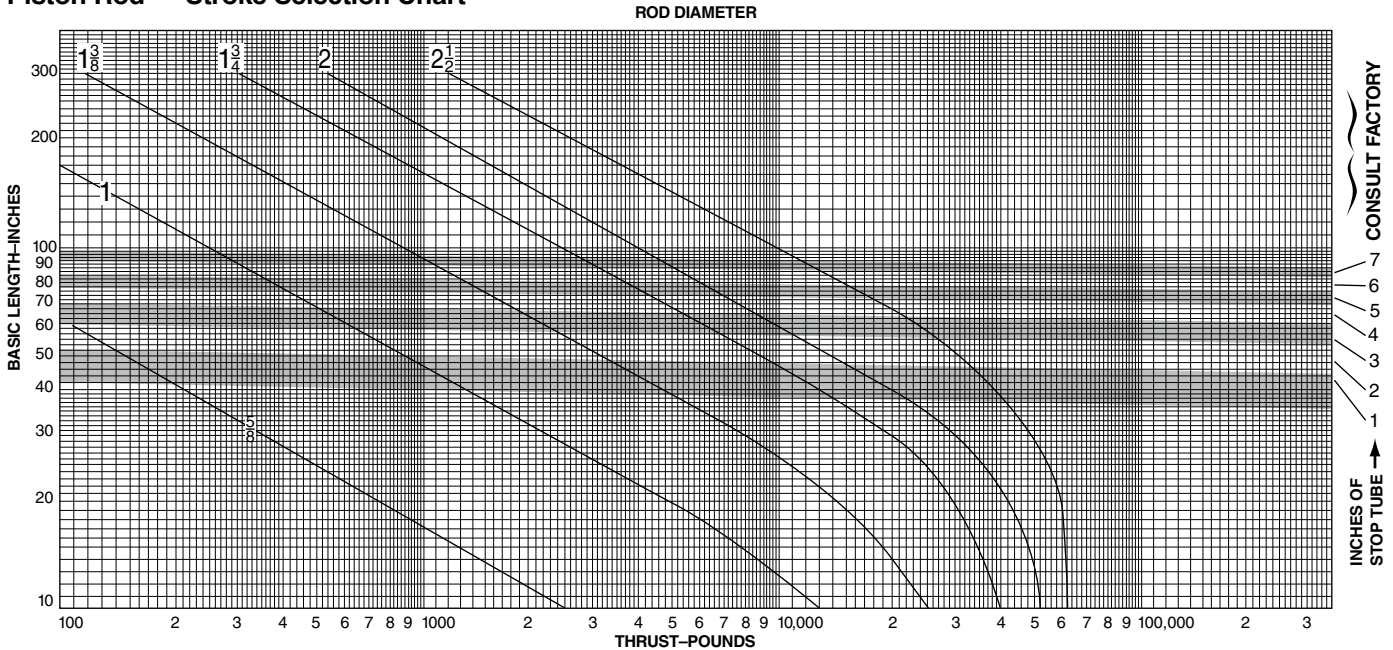

How to Use the Chart

The selection of a piston rod for thrust (push) conditions requires the following steps:



1. Determine the type of cylinder mounting style and rod end connection to be used. Then consult the chart below and find the "stroke factor" that corresponds to the conditions used.
2. Using this stroke factor, determine the "basic length" from the equation:

$$\text{Basic Length} = \text{Actual Stroke} \times \text{Stroke Factor}$$

The graph is prepared for standard rod extensions beyond the face of the gland retainers. For rod extensions greater than standard, add the increase to the stroke in arriving at the "basic length."

3. Find the load imposed for the thrust application by multiplying the full bore area of the cylinder by the system pressure.
4. Enter the graph along the values of "basic length" and "thrust" as found above and note the point of intersection:

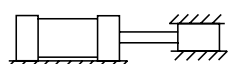
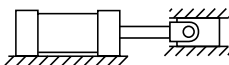
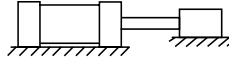
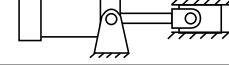
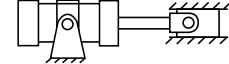
- A) The correct piston rod size is read from the diagonally curved line labeled "Rod Diameter" next *above* the point of intersection.
- B) The required length of stop tube is read from the right of the graph by following the shaded band in which the point of intersection lies.
- C) If required length of stop tube is in the region labeled "consult factory," submit the following information for an individual analysis:
 - 1) Cylinder mounting style.
 - 2) Rod end connection and method of guiding load.
 - 3) Bore, required stroke, length of rod extension (Dim. "LA") if greater than standard, and series of cylinder used.
 - 4) Mounting position of cylinder. (Note: If at an angle or vertical, specify direction of piston rod.)
 - 5) Operating pressure of cylinder if limited to less than standard pressure for cylinder selected.

Recommended Mounting Styles for Maximum Stroke and Thrust Loads	Rod End Connection	Case	Stroke Factor
Groups 1 or 3 Long stroke cylinders for thrust loads should be mounted using a heavy-duty mounting style at one end, firmly fixed and aligned to take the principal force. Additional mounting should be specified at the opposite end, which should be used for alignment and support. An intermediate support may also be desirable for long stroke cylinders mounted horizontally. Machine mounting pads can be adjustable for support mountings to achieve proper alignment.	Fixed and Rigidly Guided	I 	.50
	Pivoted and Rigidly Guided	II 	.70
	Supported but not Rigidly Guided	III 	2.00
Group 2 Style TM1 — Trunnion on Head	Pivoted and Rigidly Guided	IV 	1.00
Style TM3 — Intermediate Trunnion	Pivoted and Rigidly Guided	V 	1.50
Style TM2 — Trunnion on Cap or Style PB2 — Clevis on Cap	Pivoted and Rigidly Guided	VI 	2.00

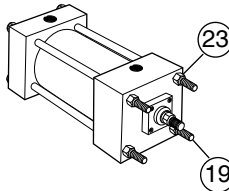
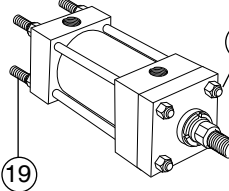
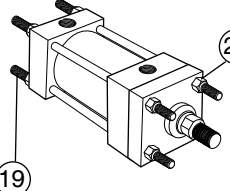
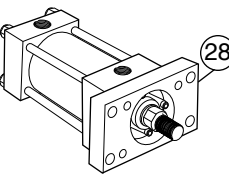
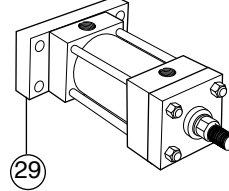
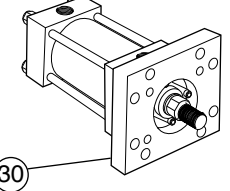
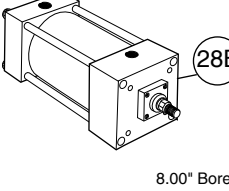
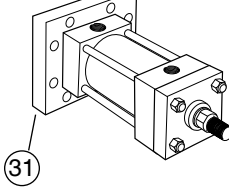
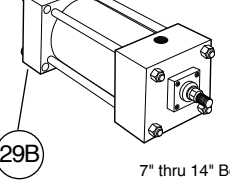
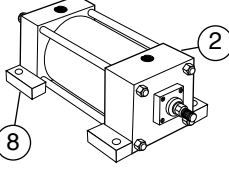
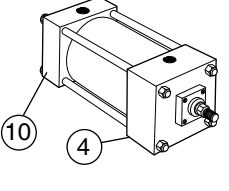
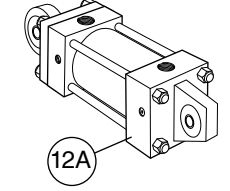
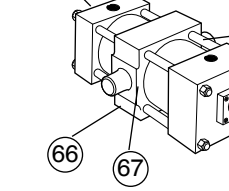
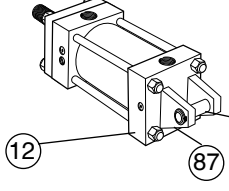
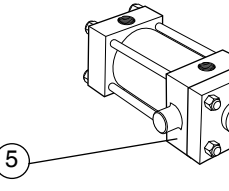
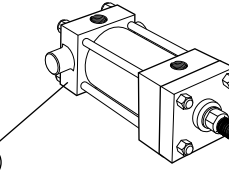
			Replacement Mountings & Hardware	
			Symbol	Description
Style NM3 	Style NM2 	Style NM1 		
Style REF2 	Style BEF2 	Style REF1 		
Style REF  8.00" Bore	Style BEF1 	Style BEF  7" thru 14" Bore		
Style SL 	Style FS 	Style SA 		
Style TM3  Screws Not Shown	Style PB2 			
Style TM1 	Style TM2 			
			How to Order Give cylinder model number, bore, stroke, serial number and symbol number shown above to insure proper replacement.	

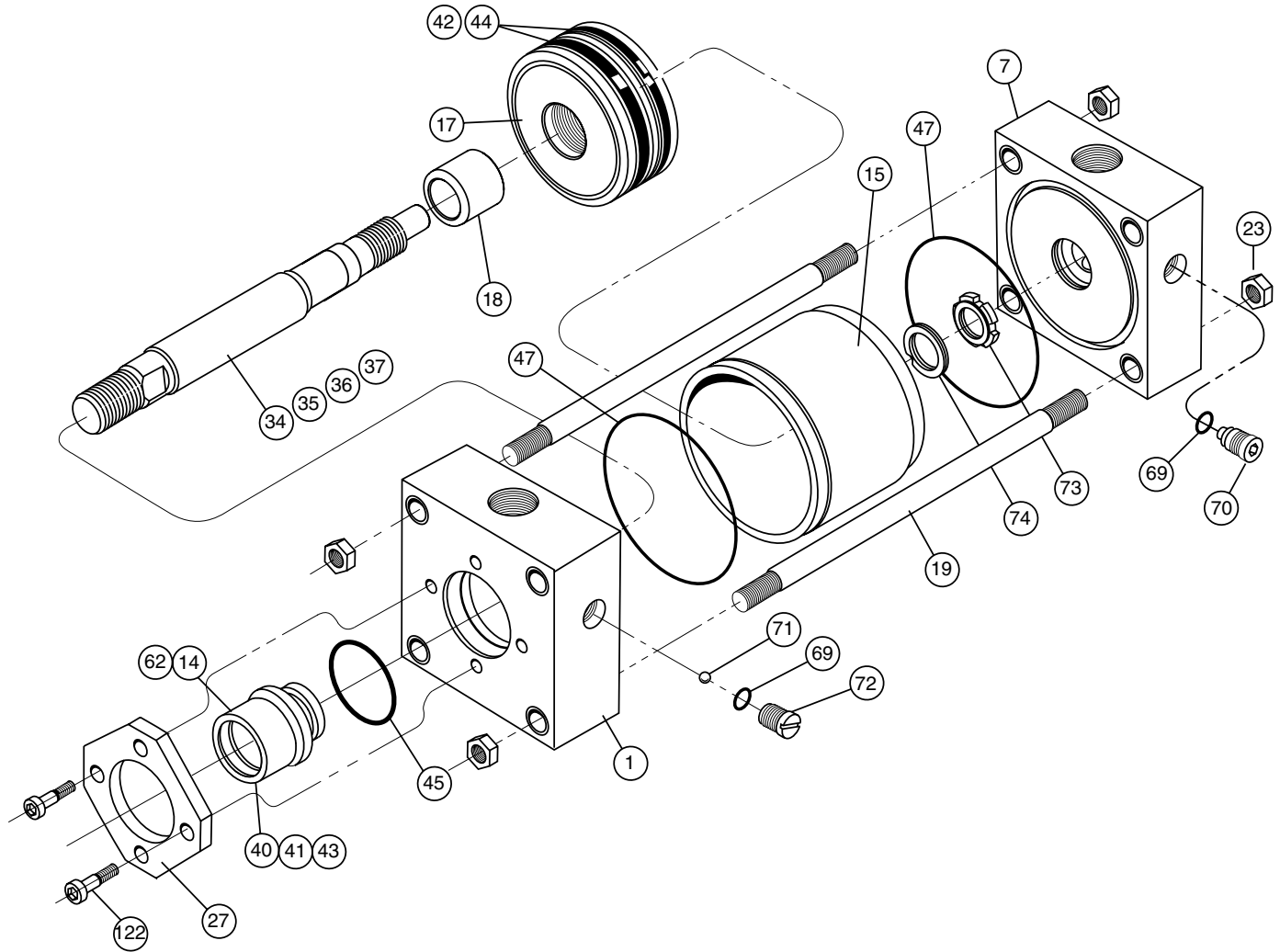

Parts		Assemblies (Includes Symbol Numbers Shown)		
Symbol	Description	Symbol	Description	Lipseal Type Piston
1	Head, ported, non-cushioned	C1SA	Head, ported, cushioned	1, 69, 70, 71 & 72
7	Cap, ported, non-cushioned	C7SA	Cap, ported, cushioned	7, 69, 70, 73 & 74
14	Gland	62	Rod gland kit	14, 40, 41, 43 & 45
15	Tube	-	-	-
17	Piston, lipseal type	-	-	-
18	Cushion sleeve, cushioned cylinder only	-	-	-
19	Tie rod	-	-	-
23	Tie rod nut	-	-	-
27	Retainer	-	-	-
34	Piston rod, single rod type, non-cushioned	34SA	Piston & rod assembly, single rod type — non-cushioned	17, 34, 42 & 44
35	Piston rod, single rod type, cushioned head end	35SA	Piston & rod assembly, single rod type — cush. head end	17, 18, 35, 42 & 44
36	Piston rod, single rod type, cushioned cap end	36SA	Piston & rod assembly, single rod type — cush. cap end	17, 36, 42 & 44
37	Piston rod, single rod type, cushioned both ends	37SA	Piston & rod assembly, single rod type — cush. both ends	17, 18, 37, 42 & 44
40	Rod wiper	-	Seal Kits	-
41	Rod seal	-		-
42	Piston seal	-		-
43	Back-up washer, gland	-		-
44	Back-up washer, piston	-		-
45	O-ring, gland to head seal	-		-
47	O-ring, cylinder tube end seal	-		-
69	O-ring, cushion adjustment & check valve screw	-		Cushion Kits See table below.
70	Needle valve, cushion adjustment	-	-	
71	Ball, check valve	-	-	
72	Plug screw, check valve	-	-	
73	Cushion bushing, cap end floating check valve	-	-	
74	Retaining ring, floating cushion bushing	-	-	-
122	Socket cap screws	-	-	-

Cushion Hardware Kits

Cushion Hardware Kits*

Bore Size	Rod Dia.	For Head Assemblies	For Cap Assemblies
1 1/2	5/8	LCUKH529	LCUKC533
	1	LCUKH529M	
2	5/8, 1	LCUKH529	LCUKC533
	1 3/8	LCUKH529M	
2 1/2	5/8 - 1 3/8	LCUKH529	LCUKC533
	1 3/4	LCUKH529M	
3 1/4	All	LCUKH530	LCUKC534
4	All	LCUKH530	LCUKC5234
5	All	LCUKH530	LCUKC534
6	All	LCUKH531	LCUKC535
8	All	LCUKH531	LCUKC535

*Cushion kits contain fluorocarbon seals and are suitable for class 1, 2, 5 & 6 service.

1 1/2" through 8" Bore Sizes

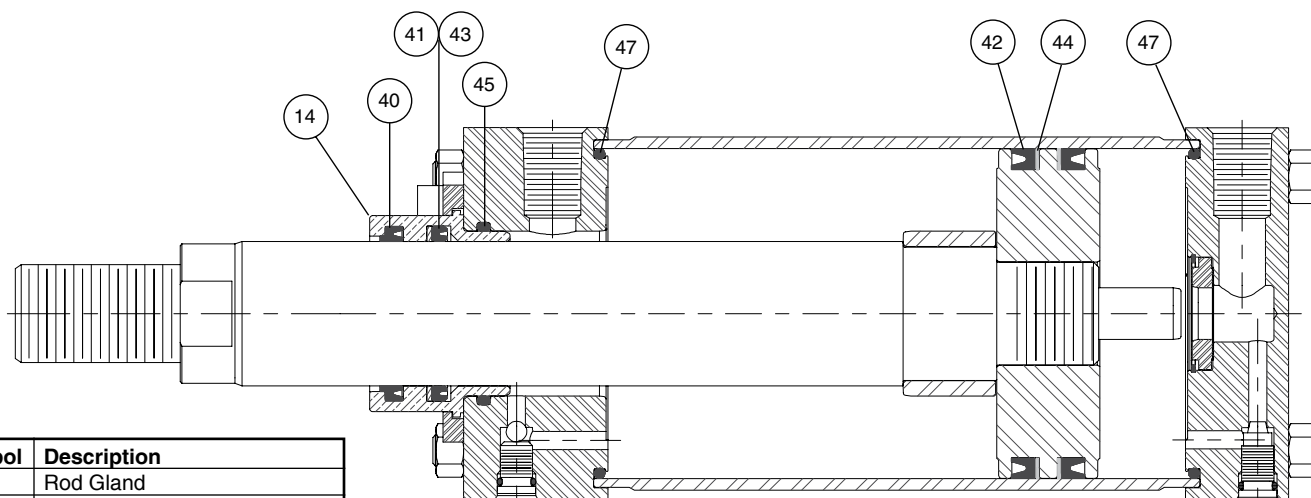

Symbol	Description
14	Rod Gland
40	Rod Wiper
41	Rod Seal
42	Piston Lipseal
43	Rod Seal Back-up Washer
44	Piston Seal Back-up Washer
45	Gland to head o-ring
47	End seal o-ring

Seal Kits

See Operating Fluids and Temperature Range Page for compatibility.

Rod Gland and Rod Seal Kits

Rod Dia.	Class 1 Polyurethane & Nitrile		Class 5 Fluorocarbon		Retainer Screw Torque Inch Lbs. (-0%, +5% tolerance)
	Rod Gland Kits (Contains: 1 Each Sym. #14, 40, 41, 43 & 45)	Rod Seal Kits (Contains: 1 Each Sym. #40, 41, 43 & 45)	Rod Gland Kits (Contains: 1 Each Sym. #14, 40, 41, 43 & 45)	Rod Seal Kits (Contains: 1 Each Sym. #40, 41, 43 & 45)	
5/8	PH06RL000	PH06SL000	VH06RL000	VH06SL000	15
1	PH10RL000	PH10SL000	VH10RL000	VH10SL000	15
1 3/8	PH13RL000	PH13SL000	VH13RL000	VH13SL000	60
1 3/4	PH17RL000	PH17SL000	VH17RL000	VH17SL000	120
2	PH20RL000	PH20SL000	VH20RL000	VH20SL000	120
2 1/2	PH25RL000	PH25SL000	VH25RL000	VH25SL000	120

Piston Seal Kits

Bore Size	Class 1 Nitrile	Class 5 Fluorocarbon	Tie Rod Nut Specification Foot Lbs.* (-0%, +5% tolerance)
	Piston Seal Kits (Contains: 2 Each Sym. #42, 44, 47)	Piston Seal Kits (Contains: 2 Each Sym. #42, 44, 47)	
1 1/2	PH00LL015	VH00LL015	5
2	PH00LL020	VH00LL020	11
2 1/2	PH00LL025	VH00LL025	11
3 1/4	PH00LL032	VH00LL032	25
4	PH00LL040	VH00LL040	25
5	PH00LL050	VH00LL050	60
6	PH00LL060	VH00LL060	60
8	PH00LL080	VH00LL080	110

*When assembling the cylinder, be sure to torque the tie rods evenly.

End of Stroke Magnetic Principle Type Proximity Switch

Reliable: Proximity type sensor never contacts cylinder moving parts; eliminating wear and adjustments.

Positive Action: Multiple magnet design provides "snap action." Eliminates creep and false signals.

Versatile: Sealed stainless steel switch body can be used with any operating fluid and is impervious to most environmental conditions.

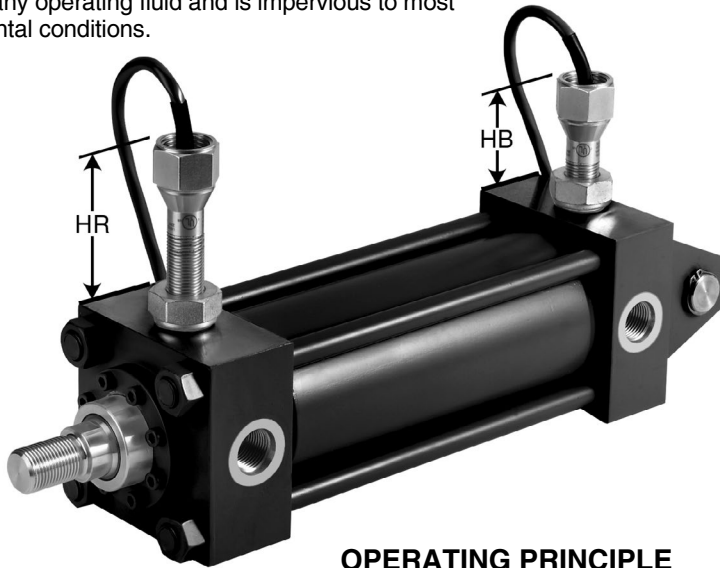

Switch Extension in Inches

Bore	Rod Dia.	HR	HB
1 1/2	5/8	3 3/8	3 1/8
	1	3 1/2	
2	5/8	3 3/16	2 7/8
	1	3 5/16	
	1 3/8	3 7/16	
2 1/2	5/8	2 15/16	2 5/8
	1	3 1/16	
	1 3/8	3 1/4	
	1 3/4	3 7/16	
3 1/4	1	3 1/8	2 3/4
	1 3/8	3 1/4	
	1 3/4	3 1/2	
	2	3 11/16	
4	1	2 3/4	2 7/16
	1 3/8	2 15/16	
	1 3/4	3 1/8	
	2	3 1/4	
5	1	2 1/4	1 15/16
	1 3/8	2 7/16	
	1 3/4	2 5/8	
	2	2 3/4	
6	1 3/8	1 15/16	1 1/2
	1 3/4	2 1/8	
	2	2 1/4	
	2 1/2	2 5/8	
8	1 3/8	2 7/16	2
	1 3/4	2 5/8	
	2	2 3/4	
	2 1/2	3 1/8	

OPERATING PRINCIPLE

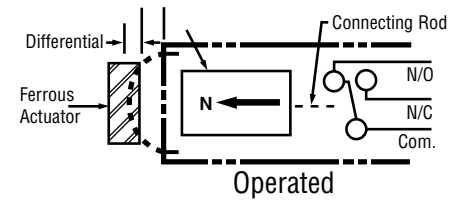
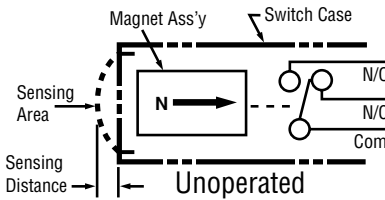

Switch Options
Quick disconnect.
Explosion proof.
Extra-long leads.

As shown in the sketches above, these switches are magnetically operated. Dual magnets provide a dependable "snap action" for positive position sensing.

In the "unoperated" position, the magnet assembly is attracted in the direction of the arrow, causing a finely ground stainless steel connecting rod to hold the contacts open.

In the "operated" position a ferrous part (cushion or piston) enters the sensing area and attracts the magnet assembly which causes the rod to draw the contacts closed.

How to Order:

To order switches, enter an "S" in the Options field of the cylinder model code. Describe the modification in notes by specifying:

1. Magnaswitch
2. Installation in head, cap, or both ends of the cylinder
3. Location in the head or cap (position #1, 2, 3, or 4) not occupied by a port or mounting

Specifications

Switch Type:
Magnetic Principle

Contacts:
Single Pole-Double Throw (SPDT)

Contact Rating*:
2 Amp at 110-240 VAC (UL & CSA)
100 MA at 12 VDC 50 MA at 24 VDC (CSA)

Note: Check current draw of solenoid valves.

Connection: 36" long, 3 wire, potted in cable. Can be wired Normally Open or Normally Closed. Leads are tagged (Com, N/O, N/C)

Switch Pressure Rating: 3000 PSI
Non Shock

Temperature Range:
-20°F to + 200°F (UL 104°F. Max.)

Sensing Gap:
.030 to .060 inch

Trip Point: Factory Set with Piston Bottomed out

Release Point: Approximately 1/4" Piston Travel

Min. Cyl. stroke 1/2" on 1 1/2" & 2" bore, 3/4" stroke on 2 1/2" and up.

*UL and CSA approved for industrial control, general purpose use. If Class I, Division 1 or 2 is required, please specify.

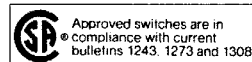

How to Order Series L Cylinders

Data Required On All Cylinder Orders

When ordering Series L cylinders, be sure to specify each of the following requirements:

(NOTE: – Duplicate cylinders can be ordered by giving the SERIAL NUMBER from the original cylinder. Factory records supply a quick, positive identification.)

- | | |
|--|---|
| <ol style="list-style-type: none"> 1. Series Designation (“L”) 2. Bore 3. Style Option (X for double rod or Y for duplex designs, blank otherwise) 4. Mounting Style
Specify your choice of mounting as shown and dimensioned in this catalog. 5. Piston Rod Diameter
Call out rod diameter. Standard (smallest) rod diameter will be furnished if not specified, unless stroke length makes the application questionable. 6. Piston Rod End Style
Call out the rod end style or specify dimensions if non-standard. Rod end style 1 will be furnished if not specified. | <ol style="list-style-type: none"> 7. Cushions
Specify cushions if required and at which end, using the codes provided. If double rod end with only one end cushioned, be sure to clearly indicate which end. 8. Ports
NPTF is standard. 9. Seals
Nitrile piston seals, polyurethane rod seal, Buna-N static seals and a wiper seal are all standard, for use with mineral base hydraulic oil. Fluorocarbon and EPR can be specified, subject to application fluid and temperature range. 10. Stroke
Specify length required. 11. Special Options
Specify. Consult factory for questions. |
|--|---|

Sample Model Code

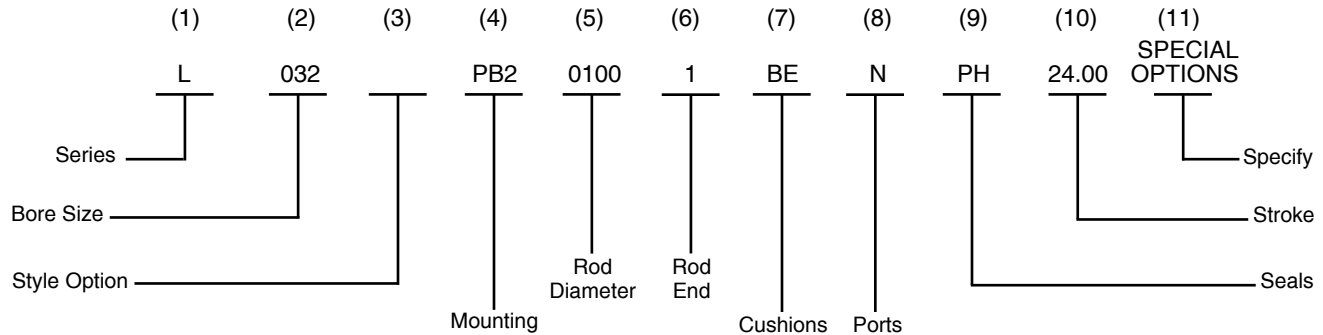

NOTE: On double rod end cylinders, repeat rod size and specify rod end threads for each side.
 For duplex cylinders, the entire model code for each cylinder should be included and indicated as “back to back” or “rod to rod.”
 If replacing existing cylinder or ordering parts, include the serial number.

Style 4 Rod End

A style 4 rod end indicates a special rod end configuration. All special rod ends must be described by at least **all three**: KK; A; or W/WF specified with the rod fully retracted. A sketch or drawing should be submitted for rod ends requiring special machining such as snap ring grooves,

keyways, tapers, multiple diameters, etc. It is good design practice to have this machining done on a diameter at least 0.065 inches smaller than the piston rod diameter. This allows the piston rod to have a chamfer preventing rod seal damage during assembly or maintenance.

Service Policy

When cylinders are returned to the factory for repairs, it is standard policy for Atlas Cylinders to make such part replacements as will put the cylinder in as good as new condition. Should the condition of the returned cylinder be such that expenses for repair exceed the cost of a new one, you will be notified.

Certified Dimensions

Atlas Cylinders guarantees that all cylinders ordered from this catalog will be built to dimensions shown. All dimensions are certified to be correct, and thus it is not necessary to request certified drawings.

Series L Ordering Guide

(1)	(2)	(3)	(4)	(5)	(6)	(7)	(8)	(9)	(10)	(11)
SERIES	BORE	STYLE	MOUNT	ROD	ROD END	CUSHIONS	PORTS	SEALS	STROKE	OPTIONS
L	015 (1.50")	<i>(Leave</i>	BEF	See "Piston Rod	1 (<i>KK Male</i>)	<i>NC (None)</i>	<i>N (NPTF)</i>	See "Operating	XXX.XX	S*
LW*	020 (2.00")	<i>Blank</i>	BEF1	Selection Chart"	2 (CC Male)	HE (Head End)	S (SAE)	Fluids" on	(Specify	(See
	025 (2.50")	<i>if</i>	BEF2	on page 50.	3 (KK Female)	CE (Cap End)	I (ISO 6149)	page 44.	Gross Stroke	Below)
	032 (3.25")	<i>Standard</i>	FS	0062 (.63")	4 (Special†)	BE (Both Ends)	X (Other)	PH Standard	if Stop Tube	
	040 (4.00")		NM1	0100 (1.00")	5 (Split Coupler)		(Specify)	Tuff Seal	is	
	050 (5.00")	X	NM2	0137 (1.38")	6 (Stub End)			Rod Seal,	Required)	
	060 (6.00")	(Double	NM3	0175 (1.75")				Nitrile		
	080 (8.00")	Rod End)	PB2	0200 (2.00")				Piston Seals		
			REF	0250 (2.50")	† Must Specify:			(Class 1 Seals)		
		Y	REF1		WF (Rod Extension)			UH Standard Tuff		
		(Duplex)	REF2		A (Thread Length)			Seal Rod Seal,		
			SA		KK (Thread Size			Poly Flex		
			SL		and Pitch)			Piston Seal		
			TM1					VH Fluorocarbon		
			TM2					Seals		
			TM3					(Class 5 Seals)		
								EH EPR Seals		
								(Class 3 Seals)		
								XH Special -		
								Specify		

(specify dimension X)

*LW – Wood Products Series L Cylinder - see below.

S* The letter S refers to special options or modifications that deviate from the standard product offering. Non-standard modifications and options not identified in the cylinder model number should be added in the notes when placing an order.

Modifications which can be placed under the designator "S" are as follows:

- End-of-Stroke Switches
 - EPS-6, EPS-7, CLS-1, CLS-4 Styles
(See bulletin AC0840-B11)
 - MagnaSwitch

Note: The standard #1 port location is at the top of the cylinder, and the standard cushion adjustment screw is in position #2 when facing the rod end of the cylinder. If multiple ports are required, the last character of the part number should be "S", indicating modified and the desired port location specified in the notes.

Cylinders for Wood Products Applications

Atlas Cylinders has built a solid reputation in the Wood Products Industry where demanding applications require a cylinder that is up to the task. That is why we offer an option that makes Atlas Cylinders the most dependable and long lasting actuator for Timber Industry service.

❖ Set screw piston to piston rod

Two axial screws in the piston-to-rod joint prevent the assembly from unthreading.

❖ Polyurethane rod wiperseal

Durable rod wiperseal cleans any oil adhering to the rod on the extend stroke and wipes the rod on the return stroke.

❖ Poly Flex Piston Seals

Durable polyurethane material with o-ring energizer for long life and positive sealing

To order your Atlas cylinder with the **Wood Products** options specify 'LW' Series and 'UH' in the seal field of the model code. See the example below.

LW	032	PB2	0137	1	BE	S	UH	10.000
Series	Bore	Mount	Rod	Rod End	Cushions	Ports	Seals	Stroke

Safety Guide for Selecting and Using Hydraulic, Pneumatic Cylinders and Their Accessories

WARNING: ⚠ FAILURE OF THE CYLINDER, ITS PARTS, ITS MOUNTING, ITS CONNECTIONS TO OTHER OBJECTS, OR ITS CONTROLS CAN RESULT IN:

- Unanticipated or uncontrolled movement of the cylinder or objects connected to it.
- Falling of the cylinder or objects held up by it.
- Fluid escaping from the cylinder, potentially at high velocity.

THESE EVENTS COULD CAUSE DEATH OR PERSONAL INJURY BY, FOR EXAMPLE, PERSONS FALLING FROM HIGH LOCATIONS, BEING CRUSHED OR STRUCK BY HEAVY OR FAST MOVING OBJECTS, BEING PUSHED INTO DANGEROUS EQUIPMENT OR SITUATIONS, OR SLIPPING ON ESCAPED FLUID.

Before selecting or using Parker Hannifin Corporation (the Company) cylinders or related accessories, it is important that you read, understand and follow the following safety information. Training is advised before selecting and using the Company's products.

1.0 General Instructions

1.1 Scope – This safety guide provides instructions for selecting and using (including assembling, installing, and maintaining) cylinder products. This safety guide is a supplement to and is to be used with the specific Company publications for the specific cylinder products that are being considered for use.

1.2 Fail Safe – Cylinder products can and do fail without warning for many reasons. All systems and equipment should be designed in a fail-safe mode so that if the failure of a cylinder product occurs people and property won't be endangered.

1.3 Distribution – Provide a free copy of this safety guide to each person responsible for selecting or using cylinder products. Do not select or use the Company's cylinders without thoroughly reading and understanding this safety guide as well as the specific Company publications for the products considered or selected.

1.4 User Responsibility – Due to very wide variety of cylinder applications and cylinder operating conditions, the Company does not warrant that any particular cylinder is suitable for any specific application. This safety guide does not analyze all technical parameters that must be considered in selecting a product. The hydraulic and pneumatic cylinders outlined in this catalog are designed to the Company's design guidelines and do not necessarily meet the design guideline of other agencies such as American Bureau of Shipping, ASME Pressure Vessel Code etc. The user, through its own analysis and testing, is solely responsible for:

- Making the final selection of the cylinders and related accessories.
- Determining if the cylinders are required to meet specific design requirements as required by the Agency(s) or industry standards covering the design of the user's equipment.
- Assuring that the user's requirements are met, OSHA requirements are met, and safety guidelines from the applicable agencies such as but not limited to ANSI are followed and that the use presents no health or safety hazards.
- Providing all appropriate health and safety warnings on the equipment on which the cylinders are used.

1.5 Additional Questions – Call the appropriate Company technical service department if you have any questions or require any additional information. See the Company publication for the product being considered or used, or call 1-847-298-2400, or go to www.parker.com, for telephone numbers of the appropriate technical service department.

2.0 Cylinder and Accessories Selection

2.1 Seals – Part of the process of selecting a cylinder is the selection of seal compounds. Before making this selection, consult the "seal information page(s)" of the publication for the series of cylinders of interest.

The application of cylinders may allow fluids such as cutting fluids, wash down fluids etc. to come in contact with the external area of the cylinder. These fluids may attack the piston rod wiper and or the primary seal and must be taken into account when selecting and specifying seal compounds.

Dynamic seals will wear. The rate of wear will depend on many operating factors. Wear can be rapid if a cylinder is mis-aligned or if the cylinder has been improperly serviced. The user must take seal wear into consideration in the application of cylinders.

2.2 Piston Rods – Possible consequences of piston rod failure or separation of the piston rod from the piston include, but are not limited to are:

- Piston rod and or attached load thrown off at high speed.
- High velocity fluid discharge.
- Piston rod extending when pressure is applied in the piston retract mode.

Piston rods or machine members attached to the piston rod may move suddenly and without warning as a consequence of other conditions occurring to the machine such as, but not limited to:

- Unexpected detachment of the machine member from the piston rod.

- Failure of the pressurized fluid delivery system (hoses, fittings, valves, pumps, compressors) which maintain cylinder position.
- Catastrophic cylinder seal failure leading to sudden loss of pressurized fluid.
- Failure of the machine control system.

Follow the recommendations of the "Piston Rod Selection Chart and Data" in the publication for the series of cylinders of interest. The suggested piston rod diameter in these charts must be followed in order to avoid piston rod buckling.

Piston rods are not normally designed to absorb bending moments or loads which are perpendicular to the axis of piston rod motion. These additional loads can cause the piston rod to fail. If these types of additional loads are expected to be imposed on the piston rod, their magnitude should be made known to our engineering department.

The cylinder user should always make sure that the piston rod is securely attached to the machine member.

On occasion cylinders are ordered with double rods (a piston rod extended from both ends of the cylinder). In some cases a stop is threaded on to one of the piston rods and used as an external stroke adjuster. On occasions spacers are attached to the machine member connected to the piston rod and also used as a stroke adjuster. In both cases the stops will create a pinch point and the user should consider appropriate use of guards. If these external stops are not perpendicular to the mating contact surface, or if debris is trapped between the contact surfaces, a bending moment will be placed on the piston rod, which can lead to piston rod failure. An external stop will also negate the effect of cushioning and will subject the piston rod to impact loading. Those two (2) conditions can cause piston rod failure. Internal stroke adjusters are available with and without cushions. The use of external stroke adjusters should be reviewed with our engineering department.

The piston rod to piston and the stud to piston rod threaded connections are secured with an anaerobic adhesive. The strength of the adhesive decreases with increasing temperature. Cylinders which can be exposed to temperatures above +250°F (+121°C) are to be ordered with a non studded piston rod and a pinned piston to rod joint.

2.3 Cushions – Cushions should be considered for cylinder applications when the piston velocity is expected to be over 4 inches/second.

Cylinder cushions are normally designed to absorb the energy of a linear applied load. A rotating mass has considerably more energy than the same mass moving in a linear mode. Cushioning for a rotating mass application should be reviewed by our engineering department.

2.4 Cylinder Mountings – Some cylinder mounting configurations may have certain limitations such as but not limited to minimum stroke for side or foot mounting cylinders or pressure de-ratings for certain mounts. Carefully review the catalog for these types of restrictions.

Always mount cylinders using the largest possible high tensile alloy steel socket head cap screws that can fit in the cylinder mounting holes and torque them to the manufacturer's recommendations for their size.

2.5 Port Fittings – Hydraulic cylinders applied with meter out or deceleration circuits are subject to intensified pressure at piston rod end.

The rod end pressure is approximately equal to:

$$\frac{\text{operating pressure} \times \text{effective cap end area}}{\text{effective rod end piston area}}$$

Contact your connector supplier for the pressure rating of individual connectors.

3.0 Cylinder and Accessories Installation and Mounting

3.1 Installation

3.1.1 – Cleanliness is an important consideration, and cylinders are shipped with the ports plugged to protect them from contaminants entering the ports. These plugs should not be removed until the piping is to be installed. Before making the connection to the cylinder ports, piping should be thoroughly cleaned to remove all chips or burrs which might have resulted from threading or flaring operations.

3.1.2 – Cylinders operating in an environment where air drying materials are present such as fast-drying chemicals, paint, or weld splatter, or other hazardous conditions such as excessive heat, should have shields installed to prevent damage to the piston rod and piston rod seals.

3.1.3 – Proper alignment of the cylinder piston rod and its mating component on the machine should be checked in both the extended and retracted positions. Improper alignment will result in excessive rod gland and/or cylinder bore wear. On fixed mounting cylinders attaching the piston rod while the rod is retracted will help in achieving proper alignment.

3.1.4 – Sometimes it may be necessary to rotate the piston rod in order to thread the piston rod into the machine member. This operation must always be done with zero pressure being applied to either side of the piston. Failure to follow this procedure may result in loosening the piston to rod-threaded connection. In some rare cases the turning of the piston rod may rotate a threaded piston rod gland and loosen it from the cylinder head. Confirm that this condition is not occurring. If it does, re-tighten the piston rod gland firmly against the cylinder head.

For double rod cylinders it is also important that when attaching or detaching the piston rod from the machine member that the torque be applied to the piston rod end of the cylinder that is directly attaching to the machine member with the opposite end unrestrained. If the design of the machine is such that only the rod end of the cylinder opposite to where the rod attaches to the machine member can be rotated, consult the factory for further instructions.

3.2 Mounting Recommendations

3.2.1 – Always mount cylinders using the largest possible high tensile alloy steel socket head screws that can fit in the cylinder mounting holes and torque them to the manufacturer's recommendations for their size.

3.2.2 – Side-Mounted Cylinders – In addition to the mounting bolts, cylinders of this type should be equipped with thrust keys or dowel pins located so as to resist the major load.

3.2.3 – Tie Rod Mounting – Cylinders with tie rod mountings are recommended for applications where mounting space is limited. The standard tie rod extension is shown as BB in dimension tables. Longer or shorter extensions can be supplied. Nuts used for this mounting style should be torqued to the same value as the tie rods for that bore size.

3.2.4 – Flange Mount Cylinders – The controlled diameter of the rod gland extension on head end flange mount cylinders can be used as a pilot to locate the cylinders in relation to the machine. After alignment has been obtained, the flanges may be drilled for pins or dowels to prevent shifting.

3.2.5 – Trunnion Mountings – Cylinders require lubricated bearing blocks with minimum bearing clearances. Bearing blocks should be carefully aligned and rigidly mounted so the trunnions will not be subjected to bending moments. The rod end should also be pivoted with the pivot pin in line and parallel to axis of the trunnion pins.

3.2.6 – Clevis Mountings – Cylinders should be pivoted at both ends with centerline of pins parallel to each other. After cylinder is mounted, be sure to check to assure that the cylinder is free to swing through its working arc without interference from other machine parts.

4.0 Cylinder and Accessories Maintenance, Troubleshooting and Replacement

4.1 Storage – At times cylinders are delivered before a customer is ready to install them and must be stored for a period of time. When storage is required the following procedures are recommended.

4.1.1 – Store the cylinders in an indoor area which has a dry, clean and noncorrosive atmosphere. Take care to protect the cylinder from both internal corrosion and external damage.

4.1.2 – Whenever possible cylinders should be stored in a vertical position (piston rod up). This will minimize corrosion due to possible condensation which could occur inside the cylinder. This will also minimize seal damage.

4.1.3 – Port protector plugs should be left in the cylinder until the time of installation.

4.1.4 – If a cylinder is stored full of hydraulic fluid, expansion of the fluid due to temperature changes must be considered. Installing a check valve with free flow out of the cylinder is one method.

4.1.5 – When cylinders are mounted on equipment that is stored outside for extended periods, exposed unpainted surfaces, e.g. piston rod, must be coated with a rust-inhibiting compound to prevent corrosion.

4.2 Cylinder Trouble Shooting

4.2.1 – External Leakage

4.2.1.1 – Rod seal leakage can generally be traced to worn or damaged seals. Examine the piston rod for dents, gouges or score marks, and replace piston rod if surface is rough.

Rod seal leakage could also be traced to gland wear. If clearance is excessive, replace rod bushing and seal. Rod seal leakage can also be traced to seal deterioration. If seals are soft or gummy or brittle, check compatibility of seal material with lubricant used if air cylinder, or operating fluid if hydraulic cylinder. Replace with seal material, which is compatible with these fluids. If the seals are hard or have lost elasticity, it is usually due to exposure to temperatures in excess of 165°F. (+74°C). Shield the cylinder from the heat source to limit temperature to 350°F. (+177°C.) and replace with fluorocarbon seals.

4.2.1.2 – Cylinder body seal leak can generally be traced to loose tie rods. Torque the tie rods to manufacturer's recommendation for that bore size.

Excessive pressure can also result in cylinder body seal leak. Determine maximum pressure to rated limits. Replace seals and retorque tie rods as in paragraph above. Excessive pressure can also result in cylinder body seal leak. Determine if the pressure rating of the cylinder has been exceeded. If so, bring the operating pressure down to the rating of the cylinder and have the tie rods replaced.

Pinched or extruded cylinder body seal will also result in a leak. Replace cylinder body seal and retorque as in paragraph above.

Cylinder body seal leakage due to loss of radial squeeze which shows up in the form of flat spots or due to wear on the O.D. or I.D. – Either of these are symptoms of normal wear due to high cycle rate or length of service. Replace seals as per paragraph above.

4.2.2 – Internal Leakage

4.2.2.1 – Piston seal leak (by-pass) 1 to 3 cubic inches per minute leakage is considered normal for piston ring construction. Virtually no static leak with lipseal type seals on piston should be expected. Piston seal wear is a usual cause of piston seal leakage. Replace seals as required.

4.2.2.2 – With lipseal type piston seals excessive back pressure due to over-adjustment of speed control valves could be a direct cause of rapid seal wear. Contamination in a hydraulic system can result in a scored cylinder bore, resulting in rapid seal wear. In either case, replace piston seals as required.

4.2.2.3 – What appears to be piston seal leak, evidenced by the fact that the cylinder drifts, is not always traceable to the piston. To make sure, it is suggested that one side of the cylinder piston be pressurized and the fluid line at the opposite port be disconnected. Observe leakage. If none is evident, seek the cause of cylinder drift in other component parts in the circuit.

4.2.3 – Cylinder Fails to Move the Load

4.2.3.1 – Pneumatic or hydraulic pressure is too low. Check the pressure at the cylinder to make sure it is to circuit requirements.

4.2.3.2 – Piston Seal Leak – Operate the valve to cycle the cylinder and observe fluid flow at valve exhaust ports at end of cylinder stroke. Replace piston seals if flow is excessive.

4.2.3.3 – Cylinder is undersized for the load – Replace cylinder with one of a larger bore size.

4.3 Erratic or Chatter Operation

4.3.1 – Excessive friction at rod gland or piston bearing due to load misalignment – Correct cylinder-to-load alignment.

4.3.2 – Cylinder sized too close to load requirements – Reduce load or install larger cylinder.

4.3.3 – Erratic operation could be traced to the difference between static and kinetic friction. Install speed control valves to provide a back pressure to control the stroke.

4.4 Cylinder Modifications, Repairs, or Failed Component – Cylinders as shipped from the factory are not to be disassembled and or modified. If cylinders require modifications, these modifications must be done at company locations or by the Company's certified facilities. The Industrial Cylinder Division Engineering Department must be notified in the event of a mechanical fracture or permanent deformation of any cylinder component (excluding seals). This includes a broken piston rod, tie rod, mounting accessory or any other cylinder component. The notification should include all operation and application details. This information will be used to provide an engineered repair that will prevent recurrence of the failure.

It is allowed to disassemble cylinders for the purpose of replacing seals or seal assemblies. However, this work must be done by strictly following all the instructions provided with the seal kits.

NOTES

Offer of Sale

The items described in this document and other documents and descriptions provided by Parker Hannifin Corporation, its subsidiaries and its authorized distributors ("Seller") are hereby offered for sale at prices to be established by Seller. This offer and its acceptance by any customer ("Buyer") shall be governed by all of the following Terms and Conditions. Buyer's order for any item described in its document, when communicated to Seller verbally, or in writing, shall constitute acceptance of this offer. All goods, services or work described will be referred to as "Products".

1. Terms and Conditions. Seller's willingness to offer Products, or accept an order for Products, to or from Buyer is subject to these Terms and Conditions or any newer version of the terms and conditions found on-line at www.parker.com/saleterms/. Seller objects to any contrary or additional terms or conditions of Buyer's order or any other document issued by Buyer.

2. Price Adjustments; Payments. Prices stated on Seller's quote or other documentation offered by Seller are valid for 30 days, and do not include any sales, use, or other taxes unless specifically stated. Unless otherwise specified by Seller, all prices are F.C.A. Seller's facility (INCOTERMS 2010). Payment is subject to credit approval and is due 30 days from the date of invoice or such other term as required by Seller's Credit Department, after which Buyer shall pay interest on any unpaid invoices at the rate of 1.5% per month or the maximum allowable rate under applicable law.

3. Delivery Dates; Title and Risk; Shipment. All delivery dates are approximate and Seller shall not be responsible for any damages resulting from any delay. Regardless of the manner of shipment, title to any products and risk of loss or damage shall pass to Buyer upon placement of the products with the shipment carrier at Seller's facility. Unless otherwise stated, Seller may exercise its judgment in choosing the carrier and means of delivery. No deferment of shipment at Buyer's request beyond the respective dates indicated will be made except on terms that will indemnify, defend and hold Seller harmless against all loss and additional expense. Buyer shall be responsible for any additional shipping charges incurred by Seller due to Buyer's acts or omissions.

4. Warranty. Seller warrants that the Products sold hereunder shall be free from defects in material or workmanship for a period of eighteen months from the date of delivery to Buyer. The prices charged for Seller's products are based upon the exclusive limited warranty stated above, and upon the following disclaimer: **DISCLAIMER OF WARRANTY: THIS WARRANTY COMPRISES THE SOLE AND ENTIRE WARRANTY PERTAINING TO PRODUCTS PROVIDED HEREUNDER. SELLER DISCLAIMS ALL OTHER WARRANTIES, EXPRESS AND IMPLIED, INCLUDING DESIGN, MERCHANTABILITY AND FITNESS FOR A PARTICULAR PURPOSE.**

5. Claims; Commencement of Actions. Buyer shall promptly inspect all Products upon delivery. No claims for shortages will be allowed unless reported to the Seller within 10 days of delivery. No other claims against Seller will be allowed unless asserted in writing within 30 days after delivery. Buyer shall notify Seller of any alleged breach of warranty within 30 days after the date the defect is or should have been discovered by Buyer. Any action based upon breach of this agreement or upon any other claim arising out of this sale (other than an action by Seller for an amount due on any invoice) must be commenced within 12 months from the date of the breach without regard to the date breach is discovered.

6. LIMITATION OF LIABILITY. UPON NOTIFICATION, SELLER WILL, AT ITS OPTION, REPAIR OR REPLACE A DEFECTIVE PRODUCT, OR REFUND THE PURCHASE PRICE. IN NO EVENT SHALL SELLER BE LIABLE TO BUYER FOR ANY SPECIAL, INDIRECT, INCIDENTAL OR CONSEQUENTIAL DAMAGES ARISING OUT OF, OR AS THE RESULT OF, THE SALE, DELIVERY, NON-DELIVERY, SERVICING, USE OR LOSS OF USE OF THE PRODUCTS OR ANY PART THEREOF, OR FOR ANY CHARGES OR EXPENSES OF ANY NATURE INCURRED WITHOUT SELLER'S WRITTEN CONSENT, EVEN IF SELLER HAS BEEN NEGLIGENT, WHETHER IN CONTRACT, TORT OR OTHER LEGAL THEORY. IN NO EVENT SHALL SELLER'S LIABILITY UNDER ANY CLAIM MADE BY BUYER EXCEED THE PURCHASE PRICE OF THE PRODUCTS.

7. User Responsibility. The user, through its own analysis and testing, is solely responsible for making the final selection of the system and Product and assuring that all performance, endurance, maintenance, safety and warning requirements of the application are met. The user must analyze all aspects of the application and follow applicable industry standards and Product information. If Seller provides Product or system options, the user is responsible for determining that such data and specifications are suitable and sufficient for all applications and reasonably foreseeable uses of the Products or systems.

8. Loss to Buyer's Property. Any designs, tools, patterns, materials, drawings, confidential information or equipment furnished by Buyer or any other items which become Buyer's property, will be considered obsolete and may be destroyed by Seller after two consecutive years have elapsed without Buyer ordering the items manufactured using such property. Seller shall not be responsible for any loss or damage to such property while it is in Seller's possession or control.

9. Special Tooling. A tooling charge may be imposed for any special tooling, including without limitation, dies, fixtures, molds and patterns, acquired to manufacture Products. Such special tooling shall be and remain Seller's property notwithstanding payment of any charges by Buyer. In no event will Buyer acquire any interest in apparatus belonging to Seller which is utilized in the manufacture of the Products, even if such apparatus has been specially converted or adapted for such manufacture and notwithstanding any charges paid by Buyer. Unless otherwise agreed, Seller shall have the right to alter, discard or otherwise dispose of any special tooling or other property in its sole discretion at any time.

10. Buyer's Obligation; Rights of Seller. To secure payment of all sums due or otherwise, Seller shall retain a security interest in the goods delivered and this agreement shall be deemed a Security Agreement under the Uniform Commercial Code. Buyer authorizes Seller as its attorney to execute and file on Buyer's behalf all documents Seller deems necessary to perfect its security interest.

11. Improper use and Indemnity. Buyer shall indemnify, defend, and hold Seller harmless from any claim, liability, damages, lawsuits, and costs (including attorney fees), whether for personal injury, property damage, patent, trademark or copyright

infringement or any other claim, brought by or incurred by Buyer, Buyer's employees, or any other person, arising out of: (a) improper selection, improper application or other misuse of Products purchased by Buyer from Seller; (b) any act or omission, negligent or otherwise, of Buyer; (c) Seller's use of patterns, plans, drawings, or specifications furnished by Buyer to manufacture Product; or (d) Buyer's failure to comply with these terms and conditions. Seller shall not indemnify Buyer under any circumstance except as otherwise provided.

12. Cancellations and Changes. Orders shall not be subject to cancellation or change by Buyer for any reason, except with Seller's written consent and upon terms that will indemnify, defend and hold Seller harmless against all direct, incidental and consequential loss or damage. Seller may change product features, specifications, designs and availability with notice to Buyer.

13. Limitation on Assignment. Buyer may not assign its rights or obligations under this agreement without the prior written consent of Seller.

14. Force Majeure. Seller does not assume the risk and shall not be liable for delay or failure to perform any of Seller's obligations by reason of circumstances beyond the reasonable control of Seller (hereinafter "Events of Force Majeure"). Events of Force Majeure shall include without limitation: accidents, strikes or labor disputes, acts of any government or government agency, acts of nature, delays or failures in delivery from carriers or suppliers, shortages of materials, or any other cause beyond Seller's reasonable control.

15. Waiver and Severability. Failure to enforce any provision of this agreement will not waive that provision nor will any such failure prejudice Seller's right to enforce that provision in the future. Invalidation of any provision of this agreement by legislation or other rule of law shall not invalidate any other provision herein. The remaining provisions of this agreement will remain in full force and effect.

16. Termination. Seller may terminate this agreement for any reason and at any time by giving Buyer thirty (30) days written notice of termination. Seller may immediately terminate this agreement, in writing, if Buyer: (a) commits a breach of any provision of this agreement (b) appoints a trustee, receiver or custodian for all or any part of Buyer's property (c) files a petition for relief in bankruptcy on its own behalf, or by a third party (d) makes an assignment for the benefit of creditors, or (e) dissolves or liquidates all or a majority of its assets.

17. Governing Law. This agreement and the sale and delivery of all Products hereunder shall be deemed to have taken place in and shall be governed and construed in accordance with the laws of the State of Ohio, as applicable to contracts executed and wholly performed therein and without regard to conflicts of laws principles. Buyer irrevocably agrees and consents to the exclusive jurisdiction and venue of the courts of Cuyahoga County, Ohio with respect to any dispute, controversy or claim arising out of or relating to this agreement.

18. Indemnity for Infringement of Intellectual Property Rights. Seller shall have no liability for infringement of any patents, trademarks, copyrights, trade dress, trade secrets or similar rights except as provided in this Section. Seller will defend and indemnify Buyer against allegations of infringement of U.S. patents, U.S. trademarks, copyrights, trade dress and trade secrets ("Intellectual Property Rights"). Seller will defend at its expense and will pay the cost of any settlement or damages awarded in an action brought against Buyer based on an allegation that a Product sold pursuant to this Agreement infringes the Intellectual Property Rights of a third party. Seller's obligation to defend and indemnify Buyer is contingent on Buyer notifying Seller within ten (10) days after Buyer becomes aware of such allegations of infringement, and Seller having sole control over the defense of any allegations or actions including all negotiations for settlement or compromise. If a Product is subject to a claim that it infringes the Intellectual Property Rights of a third party, Seller may, at its sole expense and option, procure for Buyer the right to continue using the Product, replace or modify the Product so as to make it noninfringing, or offer to accept return of the Product and return the purchase price less a reasonable allowance for depreciation. Notwithstanding the foregoing, Seller shall have no liability for claims of infringement based on information provided by Buyer, or directed to Products delivered hereunder for which the designs are specified in whole or part by Buyer, or infringements resulting from the modification, combination or use in a system of any Product sold hereunder. The foregoing provisions of this Section shall constitute Seller's sole and exclusive liability and Buyer's sole and exclusive remedy for infringement of Intellectual Property Rights.

19. Entire Agreement. This agreement contains the entire agreement between the Buyer and Seller and constitutes the final, complete and exclusive expression of the terms of sale. All prior or contemporaneous written or oral agreements or negotiations with respect to the subject matter are herein merged.

20. Compliance with Law, U. K. Bribery Act and U.S. Foreign Corrupt Practices Act. Buyer agrees to comply with all applicable laws and regulations, including both those of the United Kingdom and the United States of America, and of the country or countries of the Territory in which Buyer may operate, including without limitation the U. K. Bribery Act, the U.S. Foreign Corrupt Practices Act ("FCPA") and the U.S. Anti-Kickback Act (the "Anti-Kickback Act"), and agrees to indemnify and hold harmless Seller from the consequences of any violation of such provisions by Buyer, its employees or agents. Buyer acknowledges that they are familiar with the provisions of the U. K. Bribery Act, the FCPA and the Anti-Kickback Act, and certifies that Buyer will adhere to the requirements thereof. In particular, Buyer represents and agrees that Buyer shall not make any payment or give anything of value, directly or indirectly to any governmental official, any foreign political party or official thereof, any candidate for foreign political office, or any commercial entity or person, for the purpose of influencing such person to purchase products or otherwise benefit the business of Seller.

ATLAS
CYLINDERS

500 S. Wolf Rd.
Des Plaines, IL 60016 USA
Tel.: (847) 298-2400
Fax.: (800) 892-1008

www.AtlasCylinders.com • atlasclmktg@parker.com