

Series 4000 & 5000 Piston Accumulators

IN THIS SECTION

Overview	43
Specifications	44
Options	45
Models, Capacities & Dimensions	
Series 4000	46
Series 5000	47
Port Options	48
Parts & Accessories	49
Ordering Information	50

Features

- Heavy Duty Service with 4000 to 5000 PSI Operating Pressure
- 3" thru 9" Bores with Over 20 Standard Capacities
- V-O-ring Piston Seals
- Serviceable Threaded End Construction
- Five Standard Seal Options to Handle a Variety of Fluids & Temperatures
- Certifications Available: ASME, DNV, ABS, AS1210, SELO, CRN, GOST, CE
- Temperature Ranges -45° to 320°F



Materials

- Shell – high strength steel
- Caps – steel
- Pistons – aluminum
- Gas Valve Cartridge – stainless steel
- Gas Valve Protector – steel
- Piston Glide Rings – PTFE
- Piston & End Seals – various polymers
- Piston Seal Backups – PTFE

Actual Bore Sizes & Maximum Flow Rates

Nominal Bore Size (in)	Actual Bore Size		Max. Recommended Flow*	
	(in)	(mm)	GPM	LPM
3	3.00	76.20	220	834
4	4.03	102.4	397	1504
6	5.78	146.9	818	3096
7	7.00	178	1199	4538
9	9.00	229	1982	7502

*Note: Based on 120 in/sec maximum piston speed, port & fitting size will become limiting factors for most applications.

Pressure Ratings

Parker 4000 & 5000 PSI piston accumulators are all rated at minimum 4 to 1 design factors.

Fluids

Parker's piston accumulators are compatible with a wide variety of fluids. Standard accumulators (with nitrile seals) may be used with petroleum-based industrial oils or water-based flame resistant fluids. Optional seals compatible with most industrial fluids are available with temperature ranges from -45°F to 320°F (-43°C to 160°C).

Precharge

Units are shipped with a nominal nitrogen precharge as standard. For specific precharge pressures, specify at the time of order.

Standard Ports

The following ports are supplied as standard on all fluid ends and on the gas end of accumulators ordered for use with gas bottles:

Bore Size	Standard Ports	
	Standard Models SAE Port	Metric Models BSPP Port (in)
3	SAE #12	3/4
4	SAE #16	1
6	SAE #16	1
7	2" Code 62 Flange	2" Metric ISO 6162 Flange
9	2" Code 62 Flange	2" Metric ISO6162 Flange

Gas Valve

Series 4000 accumulators and auxiliary gas bottles are equipped with a high pressure cored gas valve cartridge as standard.

Series 5000 accumulators and gas bottles with 3" through 6" bores are supplied with a high pressure cored gas valve as standard. Models with 7" and 9" bores are supplied with a heavy duty, high-pressure, poppet-type gas valve cartridge (L07689000K) as standard.

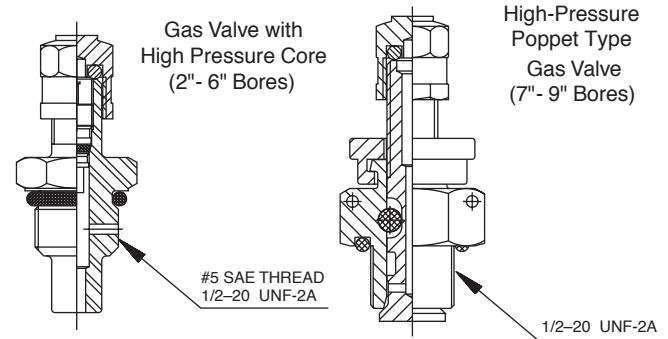

Note: The standard Parker gas cap will accept either style gas valve.

Available Options

If your application requires a piston accumulator, gas bottle, or special option that falls outside of Parker's broad offering, consult your local distributor, Parker representative, or the factory with your specific requirements. Parker has the manufacturing and engineering expertise to design and build piston accumulators to your exacting requirements, from simple modifications of standard units to complete designs. Some example of Parker's past special designs include:

- Special and Stainless Steel Materials
- High Pressures
- Extreme Temperatures
- Piston Position and Velocity Sensors and Switches
- Special Seals
- Non-Standard Capacities
- Water Service
- Ports
- Fixed Gauge Mounts
- Fuse Plug Assemblies

Auxiliary Gas Bottles

When space does not permit the installation of the required piston accumulator, a smaller accumulator may be used by connecting it to an auxiliary gas bottle(s) that can be located in a nearby spot where space is available. In some cases, a piston accumulator and gas bottle combination may be more economical, especially large capacity sizes. Piston travel, confined to the accumulator, must be calculated with ample margins to store the required fluid.

Gas Valve Option (M) - Series 4000 & 5000

3" thru 6" Bore Sizes

A heavy duty, high-pressure, poppet-type gas valve cartridge (L07689000K) is available as an option (M) – specify when ordering.

Note: This valve is standard on 7" and 9" bore sizes.

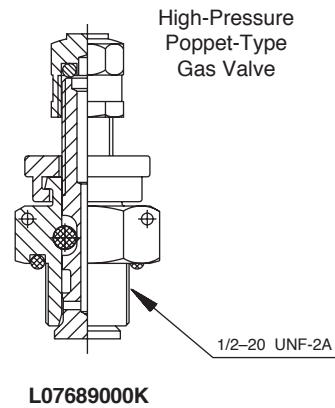

Seal Material Options

Seal Code	Polymer	Recommended Operating Temperature Range	Maximum Temperature with Reduced Life	General Application and Compatibility*
K	Buna Nitrile	-20°F to 165°F -29°C to 74°C	200°F 93°C	Parker's Standard Compound – Compatible with most mineral oil-based fluids
E	Fluorocarbon Elastomer	-10°F to 250°F -23°C to 121°C	400°F 204°C	Compatible with most mineral oil-based fluids at higher temperatures and some exotic fluids
D	Ethylene Propylene	-40°F to 250°F -40°C to 121°C	300°F 149°C	Compatible with most phosphate ester fluids and some synthetic fluids
H	Hydrogenated Nitrile	-25°F to 320°F -32°C to 160°C	350°F 177°C	Compatible with most oil-based and biodegradable fluids, maintains sealing effectiveness at a wide range of temperatures
Q	Low Temp. Nitrile	-45°F to 160°F -43°C to 71°C	200°F 93°C	Compatible with most mineral oil-based fluids and maintains sealing effectiveness at low temperatures

*Consult local distributor or factory for fluid compatibility information. Temperature ranges may vary depending upon fluid used in hydraulic system.

**The temperature listed indicates the operating temperature range of the seals, not the accumulator. For the Minimum Design Metal Temperature (MDMT) of ASME certified accumulators, refer to page 47.

Safety Fuse Options (F)

Safety Fuses are used as a safety device on accumulators and gas bottles to prevent over-pressurization of gas due to external heat or hydraulic pressure (set at 140% of maximum system pressure to avoid rupture disk fatigue and premature failure). The rupture disks are calibrated to rupture at a pre-determined pressure. Safety fuses are available on most sizes of piston accumulators. Safety fuses can be installed on all piston accumulators by using a fuse adapter. 4" bore units and above can be equipped with a fuse port machined in the gas cap by specifying the "Safety Fuse Option" (F) at the time of order in the model code, see "How to Order." The safety fuse assembly and/or fuse adapter must be ordered separately.

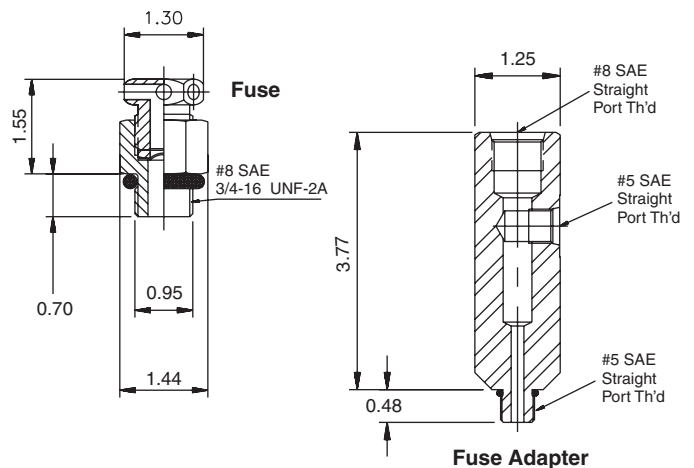

Description	Part Number
Safety Fuse Assembly ¹	086471xxxx
Replacement Rupture Disks	756003xxxx
Fuse Adapter	1468970002

¹ Assembly includes housing and rupture disk, xxxx = pressure setting in 100 PSI increments, i.e., for an assembly with a 2000 PSI setting, order P/N 0864712000.

Note: ASME and CRN units available upon request.

4000 PSI (276 Bar Metric) Piston Accumulators for Oil and Water Service

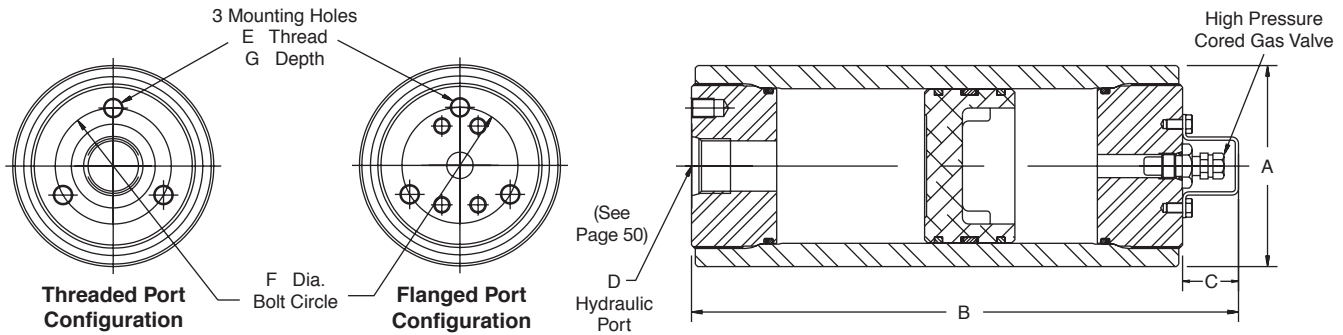

Model No.	Fluid Volume		Gas Volume		A in (mm)	B (in)	C in (mm)	E in (mm)	F in (mm)	G in (mm)	Weight lbs (Kg)
	Oil Service (cu in)	gal (Liters)	cu in	(Liters)							
A2N0005E1K (E2K)	5	(0.08)	6.5	(0.11)	2.50 (64)	6.76 (172)	1.06 (27)	—	—	—	6 (2.7)
A2N0010E1K (E2K)	10	(0.16)	11.5	(0.19)		8.31 (211)					6 (2.7)
A2N0015E1K (E2K)	15	(0.25)	16.5	(0.24)		9.78 (250)					7 (3.2)
A2N0029E1K (E2K)	29	1 Pint (0.48)	30.5	(0.50)		14.19 (360)					9 (4.1)
A2N0058E1K (E2K)	58	1 Quart (0.95)	59.5	(0.98)		23.19 (589)					14 (6.1)
A3N0029E1K (E2K)	29	1 Pint (0.48)	34	(0.56)	3.75 (96)	10.25 (260)	3/8 - 24 (M10)	2.25 (60)	0.56 (15)	—	17 (7.8)
A3N0058E1K (E2K)	58	1 Quart (0.95)	63	(1.03)		14.34 (364)					25 (11.1)
A3N0090E1K (E2K)	90	1.5 Quart (1.42)	95	(1.56)		18.94 (481)					33 (14.8)
A3N0116E1K (E2K)	116	1/2 Gal. (1.90)	121	(1.98)		22.56 (573)					39 (17.7)
A3N0183E1K (E2K)	183	3 Quart (2.84)	188	(3.08)		32.06 (814)					56 (25.4)
A4N0058E1K (E2K)	58	1 Quart (0.95)	68	(1.11)	5.00 (127)	12.06 (306)	1/2 - 20 (M12)	3.25 (82)	0.75 (18)	—	37 (16.6)
A4N0116E1K (E2K)	116	1/2 Gal. (1.90)	126	(2.06)		16.62 (422)					46 (20.6)
A4N0231E1K (E2K)	231	1 Gal. (3.79)	241	(3.95)		25.62 (651)					63 (28.7)
A4N0347E1K (E2K)	347	1-1/2 Gal. (5.69)	357	(5.85)		34.75 (883)					81 (36.8)
A4N0578E1K (E2K)	578	2-1/2 Gal. (9.47)	588	(9.64)		52.81 (1341)					117 (53.0)
A6N0231E1K (E2K)	231	1 Gal. (3.79)	266	(4.36)	7.06 (180)	19.18 (487)	1/2 - 20 (M12)	4.38 (110)	0.75 (18)	—	110 (49.8)
A6N0347E1K (E2K)	347	1-1/2 Gal. (5.69)	382	(6.26)		23.62 (600)					126 (57.2)
A6N0578E1K (E2K)	578	2-1/2 Gal. (9.47)	613	(10.0)		32.43 (824)					158 (71.9)
A6N0924E1K (E2K)	924	4 Gal. (15.1)	959	(15.70)		45.62 (1159)					207 (93.9)
A6N1155E1K (E2K)	1155	5 Gal. (18.9)	1190	(19.50)		54.43 (1383)					239 (109)
A6N1733E1K (E2K)	1733	7-1/2 Gal. (28.4)	1768	(29.00)		76.43 (1941)					320 (145)
A6N2310E1K (E2K)	2310	10 Gal. (37.9)	2345	(38.40)		98.43 (2500)					401 (182)

Notes:

- For Water Service add "W" after construction code, see "How to Order" information.
- Standard accumulators are designated E1K in model number, metric are E2K.
- See "Port Options" for complete listing of standard and optional ports.
- When accumulators are to be used with gas bottles, order "Accumulators for Use with Gas Bottles."

5000 PSI (345 Bar Metric) Piston Accumulators for Oil and Water Service

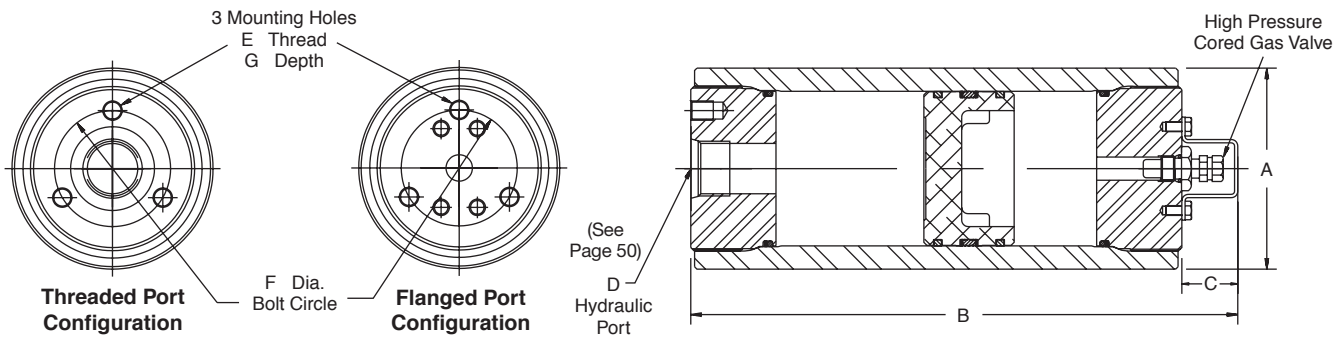

Model No.	Fluid Volume		Gas Volume		A in (mm)	B in (mm)	C in (mm)	E in (mm)	F in (mm)	G in (mm)	Weight lbs (Kg)
	Oil Service (cu in)	Gal (Liters)	cu in	(Liters)							
A2N0005C1K (C2K)	5	(0.08)	6.5	(0.11)	2.63 (67)	6.76 (172)	1.06 (27)	-	-	-	6 (2.8)
A2N0010C1K (C2K)	10	(0.16)	11.5	(0.19)		8.31 (211)					7 (3.2)
A2N0015C1K (C2K)	15	(0.25)	16.5	(0.24)		9.78 (248)					8 (3.7)
A2N0029C1K (C2K)	29	1 Pint (0.48)	30.5	(0.50)		14.19 (360)					11 (5.0)
A2N0058C1K (C2K)	58	1 Quart (0.95)	59.5	(0.98)		23.19 (589)					17 (7.6)
A3N0029C1K (C2K)	29	1 Pint (0.48)	34	(0.56)	4.00 (102)	10.25 (260)	1.13 (29)	3/8 - 12 (M10)	2.25 (60)	0.56 (15)	21 (9.6)
A3N0058C1K (C2K)	58	1 Quart (0.95)	63	(1.03)		14.34 (364)					28 (12.5)
A3N0090C1K (C2K)	90	1.5 Quart (1.47)	95	(1.56)		18.94 (481)					35 (15.7)
A3N0116C1K (C2K)	116	1/2 Gal. (1.90)	121	(1.98)		22.56 (573)					40 (18.3)
A3N0183C1K (C2K)	183	3 Quart (3.00)	188	(3.08)		32.06 (814)					55 (25.0)
A4N0058C1K (C2K)	58	1 Quart (0.95)	68	(1.11)	5.25 (134)	12.06 (306)	1.13 (29)	1/2 - 20 (M12)	3.25 (82)	0.75 (18)	43 (19.4)
A4N0116C1K (C2K)	116	1/2 Gal. (1.90)	126	(2.06)		16.62 (422)					54 (24.6)
A4N0231C1K (C2K)	231	1 Gal. (3.79)	241	(3.95)		25.62 (651)					77 (34.9)
A4N0347C1K (C2K)	347	1-1/2 Gal. (5.69)	357	(5.85)		34.75 (883)					100 (45.4)
A4N0578C1K (C2K)	578	2-1/2 Gal. (9.47)	588	(9.64)		52.81 (1341)					146 (66.2)
A6N0231C1K (C2K)	231	1 Gal. (3.79)	266	(4.36)	7.50 (191)	19.18 (487)	1.13 (29)	1/2 - 20 (M12)	4.38 (110)	0.75 (18)	128 (57.9)
A6N0347C1K (C2K)	347	1-1/2 Gal. (5.69)	382	(6.26)		23.62 (600)					148 (67.3)
A6N0578C1K (C2K)	578	2-1/2 Gal. (9.47)	613	(10.00)		32.43 (824)					190 (86.0)
A6N0924C1K (C2K)	924	4 Gal. (15.10)	959	(15.70)		45.62 (1159)					252 (114)
A6N1155C1K (C2K)	1155	5 Gal. (18.90)	1190	(19.50)		54.43 (1383)					293 (133)
A6N1733C1K (C2K)	1733	7-1/2 Gal. (28.40)	1768	(29.00)		76.43 (1941)					396 (180)
A6N2310C1K (C2K)	2310	10 Gal. (37.90)	2345	(38.40)		98.43 (2500)					499 (227)
A7K1155C1K (C2K)	1155	5 Gal. (18.90)	1190	(19.50)	9.09	42.50 (1080)	1.63 (41)	5/8 - 18 (M16)	5.75 (146)	0.94 (24)	385 (175)
A7K1733C1K (C2K)	1733	7-1/2 Gal. (28.40)	1768	(29.00)	±0.06	57.50 (1461)					495 (226)
A7K2310C1K (C2K)	2310	10 Gal. (37.90)	2345	(38.40)	(231.1	72.50 (1842)					611 (277)
A7K3465C1K (C2K)	3465	15 Gal. (56.85)	3520	(57.75)	±1.5)	102.50 (2604)					837 (380)
A9K2310C1K (C2K)	2310	10 Gal. (37.90)	2400	(39.37)	11.78 ±0.09 (299.2 ±2.3)	50.75 (1289)	1.63 (41)	3/4-16 (M19)	7.00 (178)	1.13 (29)	831 (377)
A9K3465C1K (C2K)	3465	15 Gal. (56.85)	3555	(58.33)		68.94 (1751)					1064 (483)
A9K4620C1K (C2K)	4620	20 Gal. (75.80)	4710	(77.27)		87.12 (2213)					1298 (589)
A9K5775C1K (C2K)	5775	25 Gal. (94.75)	5865	(96.23)		105.25 (2673)					1532 (695)
A9K6930C1K (C2K)	6930	30 Gal. (113.70)	7020	(115.18)		123.43 (3135)					1765 (801)

The Minimum Design Metal Temperature (MDMT) for ASME certified piston accumulators presented in this section is 20°F (-7°C).

Notes:

- For Water Service add "W" after construction code, see "How to Order" information.
- Standard accumulators are designated C1K in model number, metric are C2K.
- See "Port Options" for complete listing of standard and optional ports.

- ASME/DNV/ABS/AS1210/SELO/CRNI/GOST/CE certified accumulators and gas bottles are available.
- 2", 3", 4" & 6" bores standard with cored gas valves. Poppet type (L07689000K) gas valve available as an option.

Optional Ports

The following ports are available as options on all piston accumulators.

SAE Straight Thd.			Code 62 Flange				NPT			BSPP			ISO 6149-1		
Port Size	Port Code	Min. Bore	Port Size	Port Code		Min. Bore	Port Size	Port Code	Min. Bore	Port Size	Port Code	Min. Bore	Port Size	Port Code	Min. Bore
				Inch	Metric										
#5	TA	3"	1"	PG	MG	4"	3/8"	UT	3"	3/8"	RA	3"	M14	YA	3"
#6	TB	3"	1¼"	PH	MH	4"	1/2"	UU	3"	1/2"	RB	3"	M18	YB	3"
#8	TC	3"	1½"	PP	MV	6"	3/4"	UV	3"	3/4"	RC	3"	M22	YC	3"
#10	TI	3"	2"	PQ	MQ	6"	1"	UW	3"	1"	RD	3"	M27	YD	3"
#12	TD	3"	2½"	PR	—	7"	1¼"	UX	3"	1¼"	RE	3"	M33	YE	3"
#16	TE	3"	3"	PS	—	9"	1½"	UY	4"	1½"	RF	4"	M42	YF	3"
—	—	—	—	—	—	—	2"	UZ	4"	2"	RG	4"	—	—	—

Notes:

- 1" thru 2" flanges are to standard SAE Code 62 dimensions, 2-1/2" to "Socket Weld Flange Adapter Pattern", dimensions are shown below. Metric pattern supplied on 276 Bar Metric units unless otherwise specified.
- BSPT and Metric ports available, consult factory.

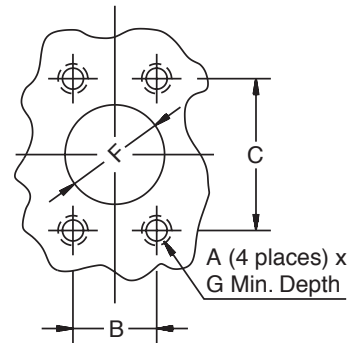

SAE 4-Bolt Flange Dimensions

Code 62 (ISO 6162) (thru 2" diameter) – 6000 PSI (410 Bar)

Flange Size		SAE Flange Dimensions (in)					Metric SAE Flange Dimensions (mm)				
in	mm	A	B	C	F	G	A	B	C	F	G
1½"	38	5/8 - 11	1.438	3.125	1½	1.375	M16	36.5	79.4	38	34.9
2"	50	3/4 - 10	1.750	3.812	2	1.500	M20	44.5	96.8	50	38.1
2½"	—	7/8 - 9	2.312	4.875	2½	1.625	—	—	—	—	—

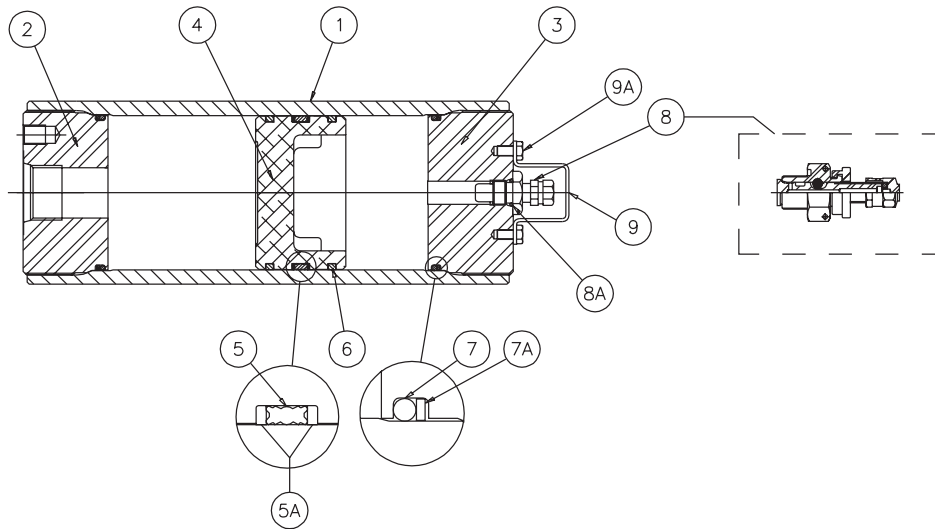

Item Part Description

- 1 Body
- 2 Hydraulic Cap
- 3 Gas Cap
- 4 Piston
- 5 V-O-Ring
- 5A V-O-Ring Back-Up Washers
- 6 PTFE Ring (Piston)
- 7 O-Ring
- 7A O-Ring Back-Up Washer
- 8 Gas Valve
- 8A Gas Valve O-Ring
- 9 Gas Valve Guard
- 9A Screw

4000 & 5000 PSI Seal Kit Numbers (Includes items 5, 5A, 6, 7, 7A, 8A)

Material	Bore Size					
	2"	3"	4"	6"	7"	9"
Buna-Nitrile (Std.)	RK0200K000	RK0300K000	RK0400K000	RK0600K000	RK0700K000	RK0900K000
Fluorocarbon	RK0200E000	RK0300E000	RK0400E000	RK0600E000	RK0700E000	RK0900E000
EPR	RK0200D000	RK0300D000	RK0400D000	RK0600D000	RK0700D000	RK0900D000
Hydrogenated Nitrile	RK0200H000	RK0300H000	RK0400H000	RK0600H000	RK0700H000	RK0900H000
Low Temp Nitrile	RK0200Q000	RK0300Q000	RK0400Q000	RK0600Q000	RK0700Q000	RK0900Q000

Mounting, Charging & Gauging Accessories

Parker offers a wide variety of mounting, charging and gauging accessories. See "Accumulator Accessories."

Charging Kit Part No. 870816 5000

Standard Assembly LH Connection with 5000 PSI Gauge



Special Options

If your application requires a piston accumulator, gas bottle, or special option that falls outside of Parker's broad offering, consult your local distributor, Parker representative, or the factory with your specific requirements. Parker has the manufacturing and engineering expertise to design and build piston accumulators to your exacting requirements, from simple modifications of standard units to complete designs. Some example of Parker's past special designs include:

- High Pressure
- Special and Stainless Steel Materials
- Piston Position and Velocity Sensors and Switches
- Special Seals
- Non-Standard Capacities
- Tie Rod Construction
- Special Certifications
- Spring & Weight Loaded
- Extreme Temperatures
- Water Service

Consult the experts at Parker with your next piston accumulator requirement!

