

S200 Series Pressure Reducing Regulators



TYPICAL S200 SERIES REGULATOR

- Wide Variety of Body Materials and End Connections Styles Available
- Fixed Factor / PFM Accuracy

- On / Off Fast Acting Loads
- Commercial / Industrial Service

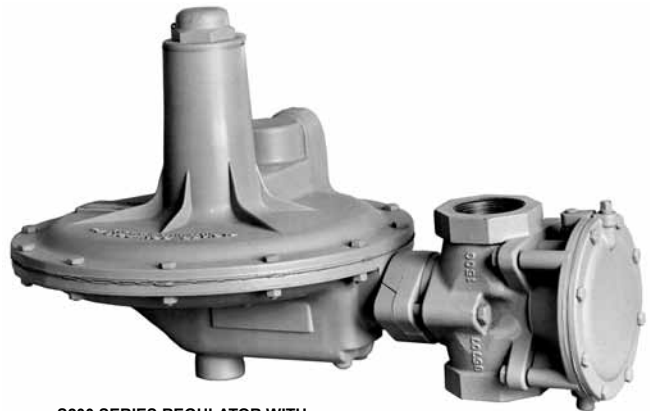

S200 SERIES REGULATOR WITH TRUE-MONITOR™



S200 SERIES REGULATOR WITH INTEGRAL SLAM-SHUT DEVICE

- Optional Internal Relief
- Optional True-Monitor
- Optional Integral Slam-Shut Device



Introduction

The quick-reacting S200 Series pressure reducing service regulator is typically used in an industrial or commercial installation to minimize the shock effect of sudden downstream load changes that might otherwise activate safety shutoff equipment. In such an installation, where gas consumption varies from almost nothing to several thousand standard cubic feet per hour (SCFH) (or normal cubic meters per hour (Nm³/h)), snap-acting solenoid valves can cause sudden load changes. The resulting shock pressures and regulator instability can cause safety equipment to shut the installation down. But with an S200 Series regulator, transmission of shock loads to downstream equipment is reduced, thereby helping maintain downstream pressures within desired limits.

The S200 Series regulators are available in several different configurations to meet the demands of varying services and overpressure protection requirements. Each configuration is made up of different construction features. The following section describes the available construction features.

- **Outlet Pressures**—The S200 Series has a wide range of outlet pressure settings from 2 inches w.c. to 10 psig / 5 mbar to 0.69 bar.
- **Fixed Factor Billing / PFM Applications**—The S200 Series can maintain outlet pressure accuracy for applications that require downstream pressure to be held within $\pm 1\%$ absolute pressure. See Tables 7 through 11.
- **Internal Relief Valve**—The Types S202, S202H, S202P, S206, S206H, and S209 have internal relief across the diaphragm to help minimize overpressure.

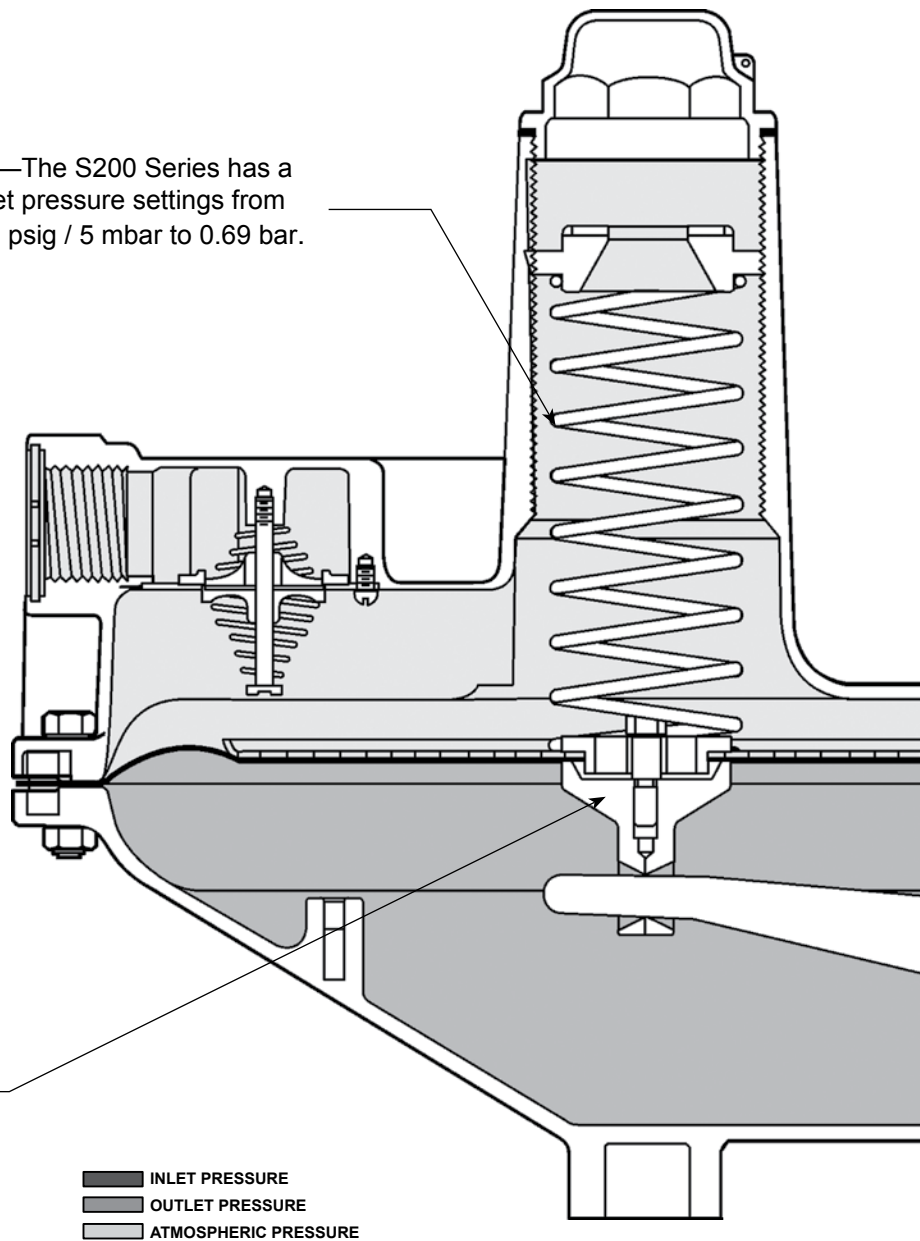
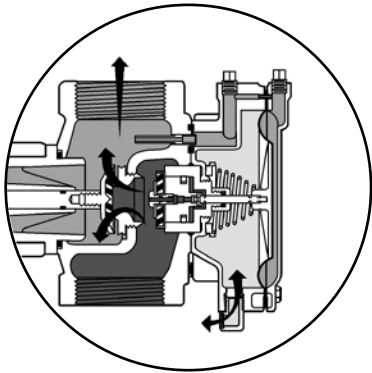
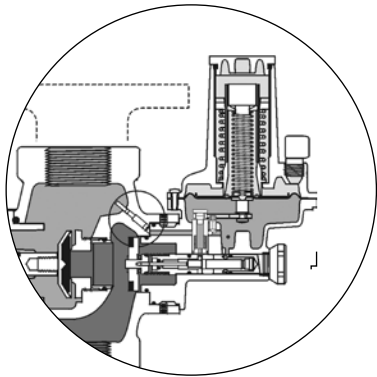

Figure 2. Type S201 Regulator (Basic S200 Series Construction)

- **Application Flexibility**—A wide variety of sizes, body materials and end connection styles available: NPS 1-1/4, 1-1/2, and 2 / DN 32, 40, and 50 body sizes available in ductile iron, steel, and cost effective cast iron available with NPT, BSP, CL125 FF (available with 7.5-inch or 10-inch / 191 or 254 mm face-to-face dimensions), CL150 RF, CL250 RF, CL300 RF, and PN 10-16 end connections. (Not all sizes and/or materials are available with all end connections. See Tables 1 and 2 for available configurations.)



- **Integral Slam-Shut Device**—The S200 Series can be configured with a Type VSX-2 integral slam-shut device to provide Overpressure Shutoff (OPSO) or Over (OPSO) and Underpressure Shutoff (UPS0).

- **True-Monitor™**—The S200 Series can be configured with an integral monitor, which functions independently from the main regulator to limit downstream pressure.

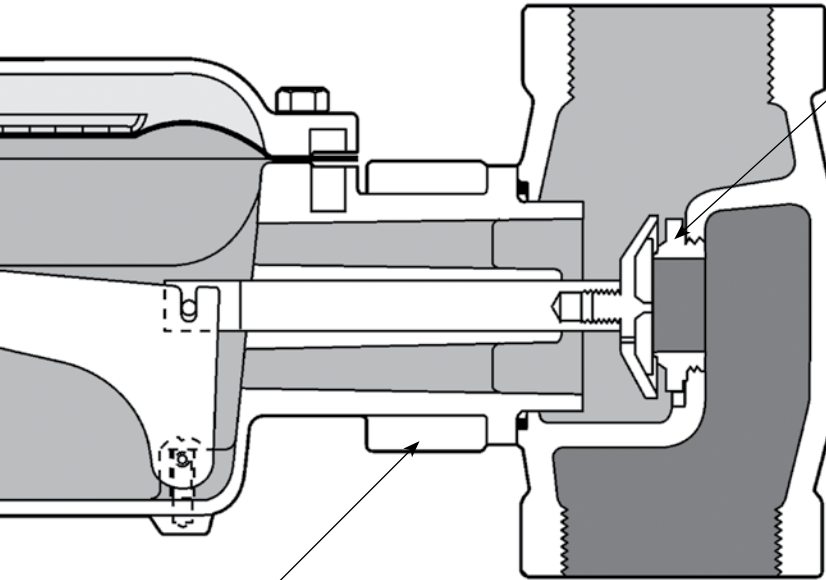

- **Orifice**—Several choices of orifice sizes to accommodate wide range of flows and inlet pressures.

- **Retrofittable**—The S200 and 299H Series use the same body and orifices. As a result, the S200 Series can easily be upgraded to a 299H Series without removing the regulator body from the pipeline.

- **Easy Inspection**—The S200 Series uses a rugged two-bolt actuator to body connection, which allows the easy and reliable access to the orifice and seat disk for inspection.

Specifications

Available Constructions (See Table 1)

Type S201: Basic construction without internal relief for 2 to 30-inches w.c. / 5 to 75 mbar outlet pressures

Type S201H: Type S201 with a heavy diaphragm plate for 1 to 5 psig / 0.07 to 0.35 bar outlet pressures

Type S201K: Type S201 with a heavy diaphragm plate for 2 to 10 psig / 0.14 to 0.69 bar outlet pressures

Type S201P: Type S201 with downstream control line connection and O-ring stem seal for external pressure registration

Type S201PK: Combination of Types S201K and S201P

Types S202, S202H, and S202P: Types S201, S201H, and S201P constructions with internal relief

Types S203, S203H, and S203P: Types S201, S201H, and S201P constructions with True-Monitor™ regulator to provide overpressure protection.

Available in Cast iron body only.

Types S204 and S204H: Types S201 and S201H constructions with a low outlet pressure shutoff.

Available in Cast iron body only.

Types S206 and S206H: Types S202 and S202H constructions with a low outlet pressure shutoff with internal relief. Available in Cast iron body only.

Types S208, S208H, S208P, S208K, and S208PK: Types S201, S201H, S201P, S201K, and S201PK constructions with a Type VSX-2 slam-shut device to provide overpressure (OPSO) or over and underpressure (UPS0) protection. Available in Ductile iron body only.

Types S209, S209H, and S209P: Types S202, S202H, and S202P constructions with a Type VSX-2 slam-shut device to provide overpressure (OPSO) or over and underpressure (UPS0) protection. Available in Ductile iron body only.

Body Sizes and End Connection Styles⁽¹⁾

See Table 2

Minimum and Maximum Inlet Pressures⁽¹⁾

Maximum Emergency (Body Rating) Inlet Pressure: 175 psig / 12.1 bar

Maximum Operating Inlet Pressure: See Table 4

Types S204 and S206 Minimum Inlet Pressure Required to Prevent Shutoff: See Figure 10

Maximum Outlet Pressure (Casing)⁽¹⁾

15 psig / 1.0 bar

Maximum Operating Outlet Pressure to Avoid Internal Part Damage⁽¹⁾

Light Diaphragm Plate: 2 psi / 0.14 bar above outlet pressure setting

Maximum Operating Outlet Pressure to Avoid Internal Part Damage (continued)⁽¹⁾

Heavy Diaphragm Plate: 3 psi / 0.21 bar above outlet pressure setting

Outlet Pressure Ranges

See Table 3

Integral Monitor Performance

See Table 5 and Figure 8

Internal Relief Performance

Internal relief valve opens at 7 to 28-inches w.c. / 17 to 70 mbar above outlet setting, depending on control spring; also see Figure 6

Type VSX-2 Trip Pressure Ranges

See Table 6

Capacities

See Tables 7 through 11

Flow Coefficients and Orifice Diameters

See Table 4

Construction Materials

S200 Series Main Valve and Actuator

Body: Cast iron, Ductile iron, or Steel; Refer to Table 1 for available constructions

Spring Case, Lower Diaphragm Casing, Union

Ring, Orifice, and Disk Holder(s): Aluminum

Disk(s), Diaphragm(s), and O-ring(s): Nitrile (NBR) or Fluorocarbon (FKM)

Closing Cap Gasket: Neoprene (CR)

Monitor Regulator Piston Ring: Graphite

Stabilizer Vent Flappers: Nylon (PA)

Type VSX-2 Slam-Shut Device

Upper and Lower Casing: Aluminum

Valve Plug: Nitrile (NBR) plug and Aluminum stem

Diaphragm and O-rings: Nitrile (NBR)

Closing Cap: ABS plastic

Reset Button: Brass

Material Temperature Capabilities⁽¹⁾

Nitrile (NBR): -20 to 150°F / -29 to 66°C

Fluorocarbon (FKM): 0 to 200°F / -18 to 93°C

(Upper temperature limitation due to Nylon (PA) flappers)

Type VSX-2: -20 to 140°F -29 to 60°C

Spring Case Vent Locations and Pressure Connections

See Figures 12 and 13

Approximate Weight

28 pounds / 13 kg

Options

- 1/8-inch NPT inlet test pressure connection
- Polytetrafluoroethylene (PTFE) diaphragm protector

1. The pressure/temperature limits in this Bulletin or any applicable standard limitation should not be exceeded.

Table 1. Available Constructions

CONSTRUCTION FEATURES	TYPE NUMBER																						
	S201	S201H	S201K	S201P	S201PK	S202	S202H	S202P	S203	S203H	S203P	S204	S204H	S206	S206H	S208	S208H	S208K	S208P	S208PK	S209	S209H	S209P
Light diaphragm plate	X					X			X			X		X		X					X		
Heavy diaphragm plate		X	X		X		X			X			X		X		X	X		X		X	
Either light or heavy diaphragm plate depending on outlet pressure range				X				X			X								X				X
Internal registration	X	X	X			X	X		X	X		X	X	X	X	X	X	X			X	X	
External registration - O-ring stem seal and downstream control line connection				X	X			X			X								X	X			X
Internal relief - Full						X	X	X							X	X							
Internal relief - Token									X	X	X										X	X	X
True-Monitor™									X	X	X												
Low outlet pressure shutoff												X	X	X	X								
Type VSX-2																X	X	X	X	X	X	X	X
BODY MATERIALS																							
Cast Iron	X	X	X	X	X	X	X	X	X	X	X	X	X	X	X								
Ductile Iron	X	X	X	X	X	X	X	X								X	X	X	X	X	X	X	X
Steel	X	X	X	X	X	X	X	X															

Table 2. Body Sizes and End Connection Styles

BODY SIZE		END CONNECTION STYLE		
NPS	DN	Cast Iron	Ductile Iron	Steel
1-1/4	32	NPT, BSP	----	----
1-1/2	40	NPT, BSP	NPT, BSP	NPT, BSP
1-1/2 x 2	40 x 50	----	NPT, BSP	----
2	50	NPT; BSP; or CL125 FF ⁽¹⁾	NPT; BSP; CL125 FF or CL250 RF flanged; or PN 10-16 flanged	NPT; BSP; CL150 RF; or PN 10-16 flanged

1. This flange is available with a face-to-face of 7.5 inches / 191 mm or 10 inches / 254 mm.

Table 3. Outlet Pressure Ranges

TYPE	SPRING NUMBER	OUTLET PRESSURE RANGE	CONTROL SPRING	
			Part Number	Color Code
S201, S202, S203 ⁽¹⁾ , S208, S209, S201P, S202P, S203P, S208P, and S209P	----	2 to 4.5 inches w.c. / 5 to 11 mbar ⁽²⁾⁽³⁾	1D892527022	Brown
	1	3.5 to 6.5 inches w.c. / 9 to 16 mbar	1D892627022	Red
	2	5 to 9 inches w.c. / 12 to 22 mbar	1D892727012	Black
	3	8.5 to 18 inches w.c. / 21 to 45 mbar	1D893227032	Gray
S204 and S206	----	14 to 30 inches w.c. / 35 to 75 mbar	1D893327032	Dark Green
	----	3.5 to 5 inches w.c. / 9 to 12 mbar ⁽²⁾	1D892527022	Brown
	----	5 to 7 inches w.c. / 12 to 17 mbar	1D892627022	Red
	----	6.5 to 9.5 inches w.c. / 16 to 23 mbar	1D892727012	Black
S201H, S202H, S203H ⁽¹⁾ , S208H, S209H, S201P ⁽⁴⁾ , S202P ⁽⁴⁾ , S203P ⁽⁴⁾ , S204H, S206H, S208P ⁽⁴⁾ , and S209P ⁽⁴⁾	----	8.5 to 18 inches w.c. / 21 to 45 mbar	1D893227032	Gray
	----	14 to 30 inches w.c. / 35 to 75 mbar	1D893327032	Dark Green
	5	1 to 2 psig / 0.07 to 0.14 bar	1H975827032	Dark Blue
S201K, S201PK, S208K, and S208PK	6	1.5 to 3.25 psig / 0.10 to 0.22 bar	1H975927032	Orange
	7	2 to 5 psig / 0.14 to 0.34 bar ⁽⁵⁾	1P615427142	Yellow
	8	2 to 5.5 psig / 0.14 to 0.38 bar	0Y066427022	Green Stripe
S204H and S206H	9	4 to 10 psig / 0.28 to 0.69 bar	1H802427032	Unpainted
	----	1 to 2 psig / 0.07 to 0.14 bar	1H975827032	Dark Blue
	----	1.5 to 3.25 psig / 0.10 to 0.22 bar	1H975927032	Orange

1. Types S203 and S203H outlet pressure ranges are a function of the monitor construction / monitor spring and the number of spring seats used. See Table 5 for more information.
 2. With regulator installed so control spring is on top of diaphragm. If installed so control spring is on bottom, lower end of outlet pressure range can be reduced by 1 inch w.c. / 2 mbar for regulator with light diaphragm plate or 2 inches w.c. / 5 mbar for regulator with heavy diaphragm plate.
 3. Not available with Types S208 and S209.
 4. Types S201P, S202P, S203P, S208P, and S209P require heavy diaphragm plate for outlet pressures over 1 psig / 0.07 bar.
 5. Not available for Types S203P, S204H, and S206H.

Bulletin 71.1:S200

Table 4. Additional Specifications

TYPE	OUTLET PRESSURE SETTING	ORIFICE SIZE		MAXIMUM OPERATING INLET PRESSURE TO OBTAIN OPTIMUM PERFORMANCE		WIDE-OPEN C _g	WIDE-OPEN C _v	C ₁
		Inches	mm	psig	bar			
S201, S201P, S202, S202P, S203, S203P, S208, S208P, S209, and S209P	2 to 30 inches w.c. / 5 to 75 mbar	1/4	6.4	125	8.6	53	1.51	35
		3/8	9.5	125	8.6	110	3.14	
		1/2	13	100	6.9	190	5.43	
		3/4	19	60	4.1	415	11.9	
		1	25	25	1.7	700	20	
		1-3/16	30	13	0.90	910	26	
S201H, S201P, S202H, S202P, S203H, S203P, S208H, S208P, S209H, and S209P	1 to 3.25 psig / 0.07 to 0.22 bar	1/4	6.4	125	8.6	53	1.51	
		3/8	9.5	125	8.6	110	3.14	
		1/2	13	100	6.9	190	5.43	
		3/4	19	60	4.1	415	11.9	
		1	25	30	2.1	700	20	
	1-3/16	30	14	1.00	910	26		
	2 to 5 psig / 0.14 to 0.34 bar	1-3/16	30	20	1.4	910	26	
S201K, S201PK, S208K, and S208PK	All outlet pressure settings	1/4	6.4	125	8.6	53	1.51	
		3/8	9.5	125	8.6	110	3.14	
		1/2	13	100	6.9	190	5.43	
		3/4	19	60	4.1	415	11.9	
		1	25	30	2.1	700	20	
	1-3/16	30	20	1.4	910	26		
	4 to 10 psig / 0.28 to 0.69 bar	1-3/16	30	25	1.7			
S204 and S206	3.5 to 30 inches w.c. / 9 to 75 mbar	3/8	9.5	100	6.9	38	1.09	
		1/2	13	100	6.9	115	3.29	
		3/4	19	75	5.2	230	6.57	
		1	25	30	2.1	625	17.9	
		1-3/16	30	15	1.0	835	23.9	
S204H and S206H	1 to 3.25 psig / 0.07 to 0.22 bar	3/8	9.5	100	6.9	38	1.09	
		1/2	13	100	6.9	115	3.29	
		3/4	19	75	5.2	230	6.57	
		1	25	30	2.1	625	17.9	
		1-3/16	30	15	1.0	835	23.9	

Construction Features

Heavy-Duty Construction for Higher Outlet Pressures

An S200 Series regulator with an H or K (Figure 3) in the type number can deliver air or gas at a higher outlet pressure setting than the basic Type S201 (see Table 3). S200 Series regulators with an H or K in the type number have a heavy diaphragm plate, while most other S200 Series regulators have a light diaphragm plate. However, a regulator with a P in the type number will have a light diaphragm plate for outlet pressure ranges under 1 psig / 0.07 bar and a heavy diaphragm plate outlet pressure ranges over 1 psig / 0.07 bar.

Downstream Control Line Connection

An S200 Series regulator with a P or a PK in the type number has a blocked turbo-booster tube, an O-ring stem seal, and a 3/4 NPT control line tapping in the lower diaphragm casing. A regulator with a downstream control line is used for monitoring installations or other applications where there is other equipment installed between the regulator and the pressure control point. The O-ring stem seal helps separate body pressure from diaphragm case pressure on monitor installations where leakage cannot be tolerated.

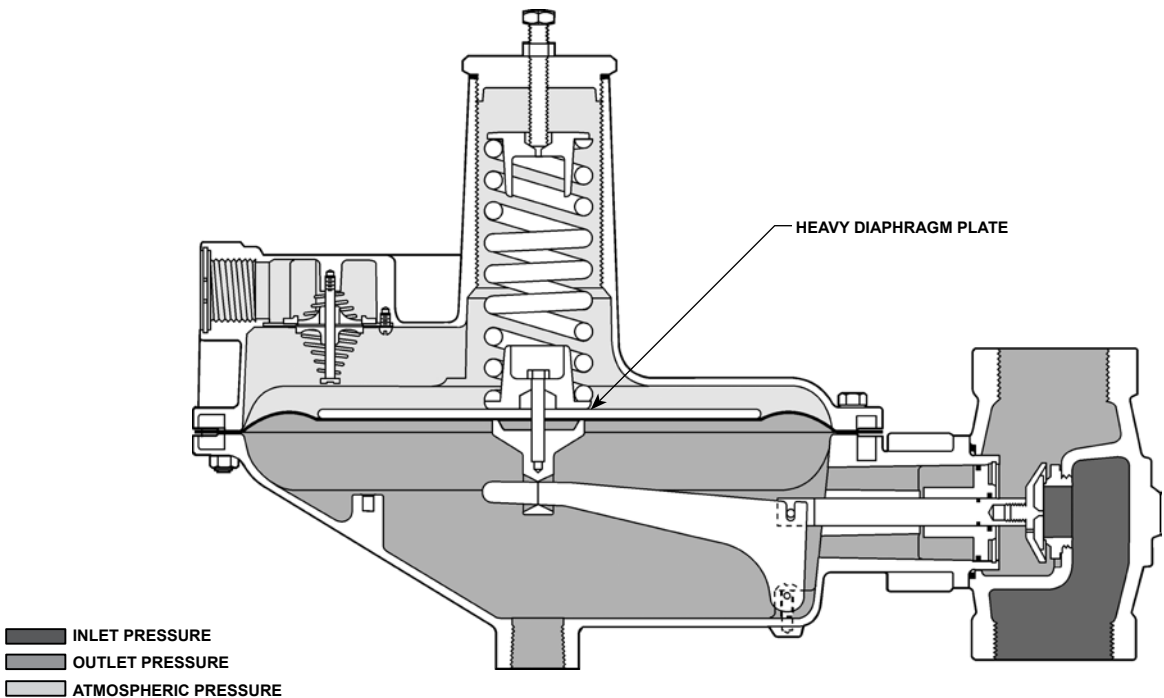

Figure 3. Type S201PK Regulator with Heavy Diaphragm Plate for Higher Outlet Pressures

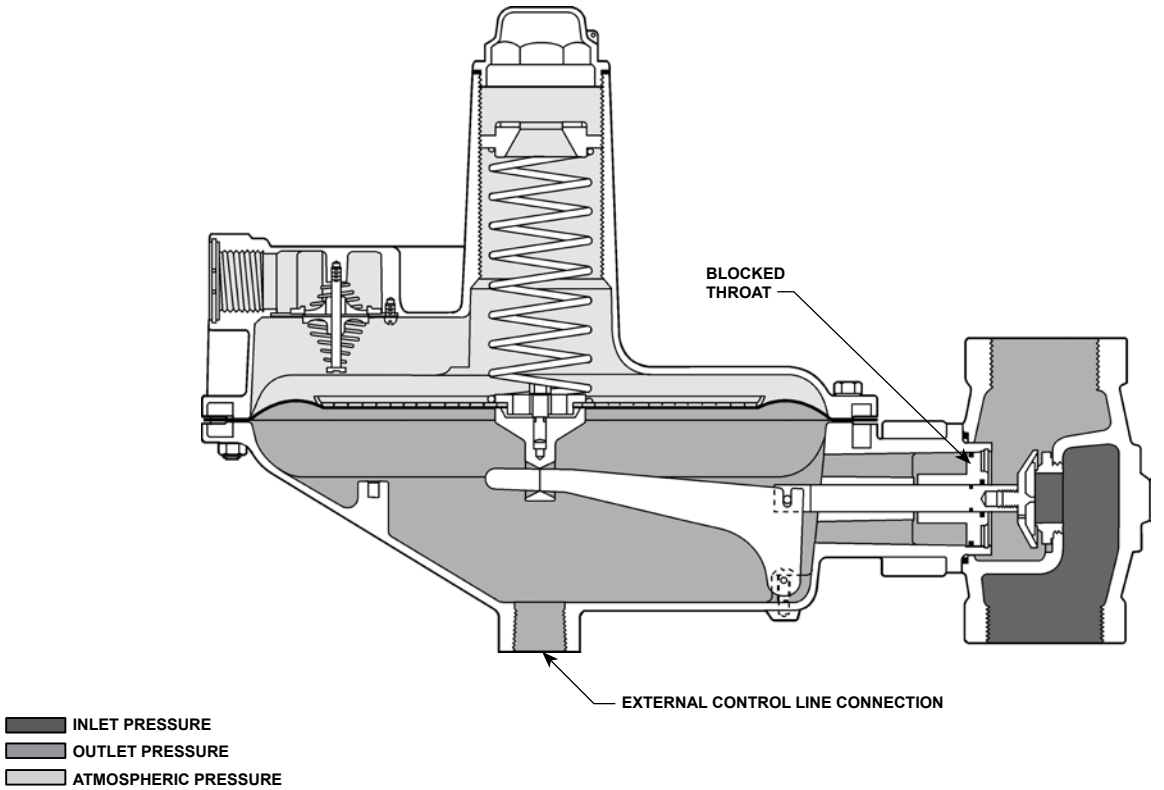

Figure 4. Type S201P Regulator with Downstream Control Line Connection

Internal Relief

Several S200 Series regulators have relief across the diaphragm (Figure 5) to help minimize overpressure. Any outlet pressure above the start-to-discharge point of the nonadjustable relief spring moves the diaphragm off the relief seat, allowing excess pressure to bleed out through the screened stabilizer vent.

For extra protection, should emergency conditions exist which prevent normal operation of the regulator (for example, linkage becoming disconnected or disk broken off), the relief stem contacts the underside of the closing cap, limiting the rise of the relief. Since the diaphragm continues to rise as downstream pressure builds, it lifts off the relief, thereby opening the valve to provide relief operation.

True-Monitor™

The Types S203, S203H, and S203P are available with a True-Monitor regulator, which is integral yet acts independently of the main regulator. The monitor provides equivalent overpressure protection when compared to a standard two-regulator monitor setup. If one regulator fails, the other regulator provides control and overpressure protection. The monitor construction provides the following important features:

- **Designed to Meet or Exceed Applicable Requirements of DOT 192.197**—In DOT 192.197 paragraph “b” which states “or if the gas contains material that seriously interferes with the operation of service regulators, there must be suitable protective devices to prevent unsafe overpressuring of the customer’s appliances if the service regulator fails.” The Type S203 is designed to address the above issue and other common types of failures found in service regulators, such as lever arm, pusher post, and stem failures.
- **Minimizing of Hazardous Venting**—Required relief capacity is cut down without restricting total regulator capacity. The internal token relief and monitor work in combination to limit relief discharge to atmosphere. The internal token relief also acts as an alarm to indicate when the monitor is operating.
- **Lower Controlled Downstream Pressure**—In the event of regulator failure, the monitor regulator limits downstream pressure.
- **All-Dynamic Operation with Automatic Reset**—The monitor diaphragm and piston are in motion under normal operating conditions, prepared to provide overpressure protection when needed. No manual reset procedure is required to return

the regulator to normal operation after relief of the overpressure condition.

As downstream pressure registers under the main diaphragm, it also registers on top of the monitor diaphragm through the pitot tube located near the body outlet. Under normal conditions as downstream pressure fluctuates due to load changes, the main regulator disk and the monitor piston move toward or away from the orifice.

If downstream pressure begins to increase due to main regulator failure, and if the downstream pressure increases to 7 to 28 inches w.c. / 17 to 70 mbar above set pressure, the internal relief valve begins to open to limit downstream pressure. At the same time, the increasing pressure is sensed on the monitor diaphragm (see Figure 7) causing the monitor piston to move towards the orifice to restrict the flow through the regulator to limit the downstream pressure. While the monitor is in operation, regardless of the downstream demand, the token internal relief valve will continuously operate due to the engineered bleed in the monitor piston. This bleed allows a minimal amount of flow to exhaust to atmosphere to notify the user that the regulator is operating in monitor mode.

As downstream pressure drops back to normal, the piston moves back away from the orifice and the internal relief valve closes, automatically allowing normal operation again.

The combination of a restriction in the internal relief valve and the monitor piston positioned near the inlet side of the orifice limits the maximum downstream pressure and the related flow through the internal relief valve to the values shown in Table 5 and Figure 8.

Low Outlet Pressure Shutoff

On installations requiring a minimum outlet pressure, the Types S204 and S206 regulator (Figure 9) and the Types S204H and S206H regulator with low outlet pressure shutoff shuts the regulator off if the required minimum outlet pressure cannot be maintained. With the flow shut off, the possibility of gas accumulation downstream of the regulator is minimized.

As downstream pressure drops under high demand or because the inlet pressure is too low, the diaphragm drops to its lowest position and the main disk moves to its farthest position from the orifice. This allows the spring in the back disk assembly to seat the back disk against the orifice and shut off flow. This condition is maintained until the regulator is manually reset by pulling upward on the pusher post extension in the spring case.

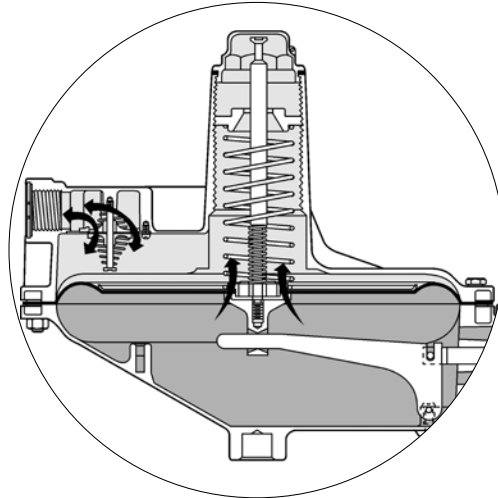

INLET PRESSURE
 OUTLET PRESSURE
 ATMOSPHERIC PRESSURE

Figure 5. Type S202 Regulator with Internal Relief

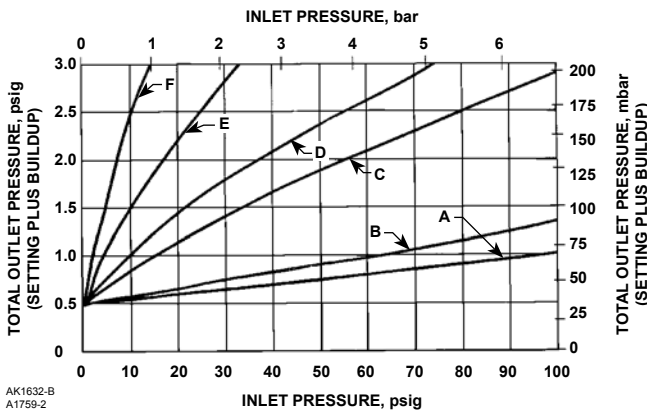

AK1632-B
A1759-2

7 INCHES W.C. / 17 mbar
TYPE S202 OR S206 REGULATOR WITH SEAT BLOCKED
OPEN BY TWO 1/8-INCH / 3.2 mm DIAMETER WIRES

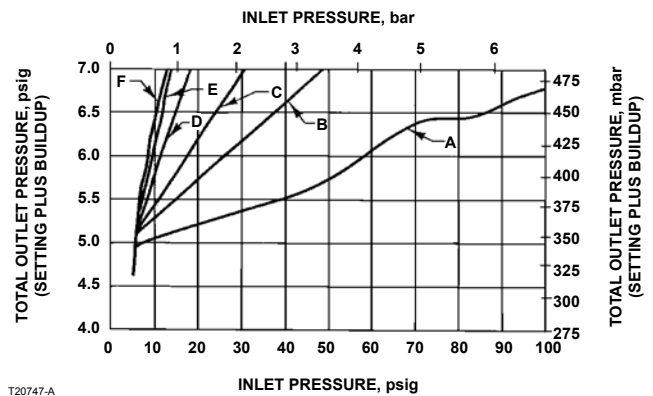

T20747-A
A2773-1

5 psig / 0.34 bar
TYPE S202H REGULATOR WITH SEAT BLOCKED
OPEN BY ONE 1/8-INCH / 3.2 mm DIAMETER WIRE

CURVE	PORT DIAMETER	
	Inches	mm
A	1/4	6.4
B	3/8	9.5
C	1/2	13
D	3/4	19
E	1	25
F	1-3/16	30

Figure 6. Internal Relief Performance for Types S202, S202H, and S206 Regulators Venting Directly to Atmosphere

Type VSX-2 Slam-Shut Device

The Type VSX-2 slam-shut device on the Types S208 and S209 regulators is a fast acting shutoff valve which provides overpressure (OPSO) or over and underpressure (UPS0) protection by completely shutting off the flow of gas to the downstream system. The shutoff module's actions are independent of the Types S208 and S209 regulators and of variations to

the inlet pressure. The Type VSX-2 has internal or external registration. External registration requires a downstream sensing line.

The shutoff disk is held in the open position (reset position) by a small ball holding the disk stem. If the pressure below the diaphragm increases (or decreases) reaching the Type VSX-2 setpoint,

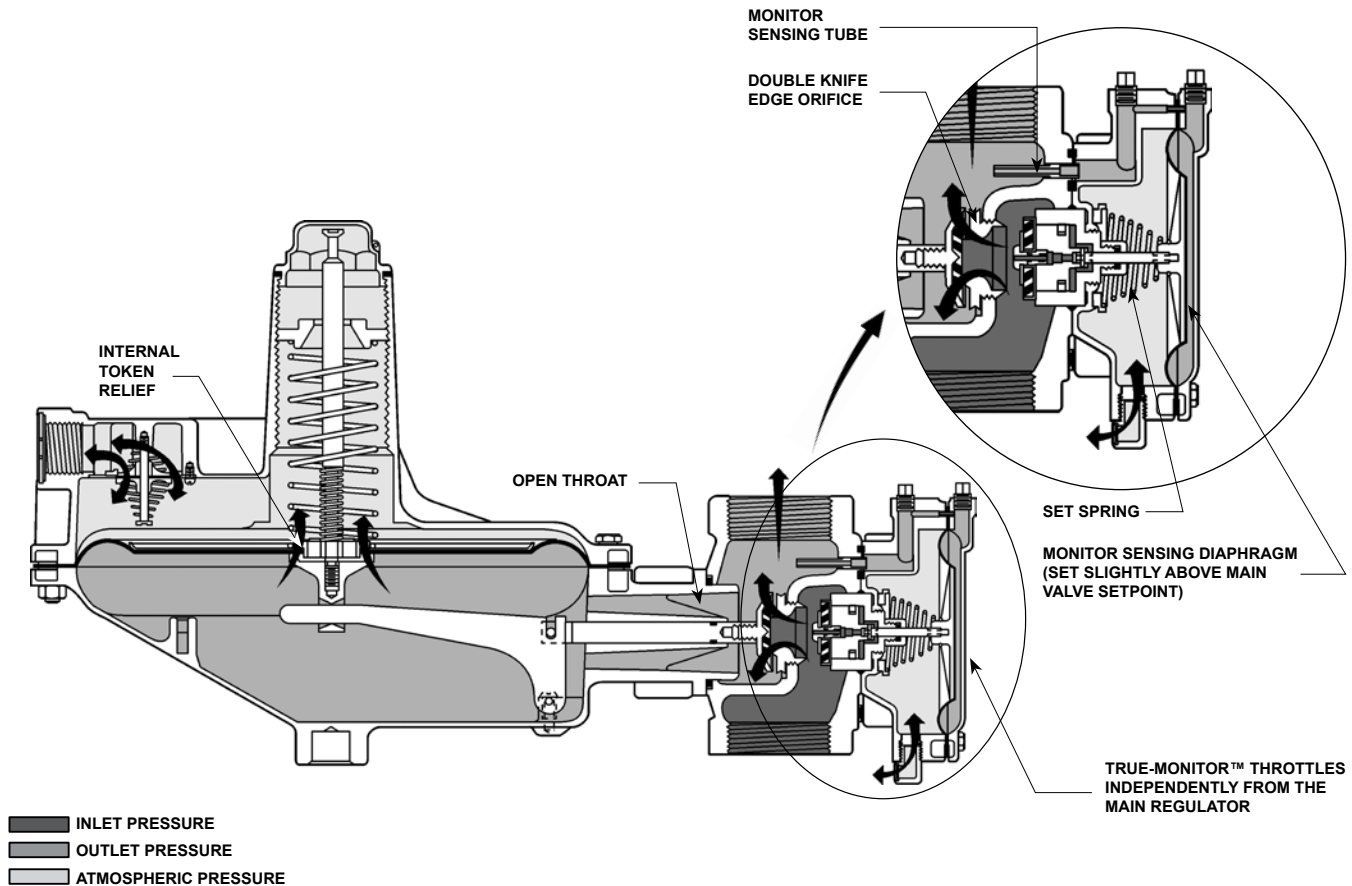

Figure 7. Type S203 Regulator with True-Monitor

the diaphragm will travel upwards (or downwards) operating a lever which in turn releases the ball.

Once the ball is released, the spring force on the stem will push the stem and disk against the seat, shutting off all gas flow. The manual reset has an internal bypass to equalize the reset pressure on either side on the shutoff disk.

In order for the Underpressure Shutoff (UPS) of any slam shut to be triggered, the downstream pipe pressure must drop below the UPS setpoint. In the case of a downstream line break, numerous factors can prevent the downstream pipe pressure from decreasing below the slam-shut UPS setpoint. These factors include the distance of pipe to the break, the diameter of the pipe, size of the break, and the number of restrictions, such as valves, elbows and bends, downstream of the regulator and/or slam-shut device. Due to these factors additional protections should be installed to stop flow in the event of a line break.

Overpressure Protection

The S200 Series regulators have outlet pressure ratings that are lower than their inlet pressure ratings. A pressure relieving or pressure limiting device is needed for Types S201, S201H, S201K, S201P, S201PK, S204, and S204H if inlet pressure can exceed the outlet pressure rating, since these regulators do not have internal relief, high outlet pressure shutoff, or integral slam-shut device.

Type S202, S202H, S202P, S203, S203H, or S203P, Types S206 and S206H have internal relief or relief monitoring to provide partial capacity relief, limiting total outlet pressure as shown in Figures 6 and 8. This partial internal relief may be adequate; if not, an additional pressure relieving or pressure limiting device should be installed downstream.

Types S208 and S209 regulators rely on the Type VSX-2 slam-shut device for overpressure protection. The Type VSX-2 will shut the system down until the problem can be rectified and the Type VSX-2 is reset. Type S209 regulators have internal relief which provides token capacity relief for thermal expansion.

Table 5. Integral Monitor Data

TYPE	CONTROL SPRING PART NUMBER AND COLOR (SEE TABLE 3 FOR RANGE)	OUTLET PRESSURE RANGE		MAXIMUM DOWNSTREAM PRESSURE WITH INTEGRAL MONITOR IN OPERATION		MAXIMUM FLOW THROUGH INTERNAL RELIEF VALVE WITH INTEGRAL MONITOR IN OPERATION ⁽¹⁾		RELIEF MONITOR SPRING PART NUMBER AND COLOR	NUMBER OF SPRING SEATS REQUIRED
		Inches w.c.	mbar	psig	bar	SCFH	Nm ³ /h		
S203 and S203P	1D892527022, Brown	0 to 5	0 to 12	0.8	0.06	950	25.5	1L255727132, Green	0
	1D892627022, Red 1D892727012, Black	4 to 9.5	10 to 24	--- ⁽²⁾	--- ⁽²⁾	1000	26.8	1L255727132, Green	1
	1D893227032, Gray	8 to 14	20 to 35	--- ⁽²⁾	--- ⁽²⁾	1200	32.2	1L255727132, Green	2
		8 to 12	20 to 30	1.4	0.10	1350	36.2	1L255827132, Red	0
10 to 20		25 to 50	1.8	0.12	1600	42.9	1L255827132, Red	1	
11 to 21		27 to 52	2.2	0.15	1800	48.2	1L255927132, Blue	0	
1D893327032, Dark Green	14 to 28	35 to 70	2.8	0.19	1900	50.9	1L255827132, Red	2	
	18 to 33 0.5 to 1.0 psig	45 to 82 35 to 70	3.0 3.0	0.21 0.21	2000 2200	53.6 60.0	1L255927132, Blue 1V224227012, Silver	1 0	
S203H and S203P	1H975827032, Dark Blue	1.0 to 1.6 psig 0.75 to 1.6 psig	70 to 110 52 to 110	3.8 4.0	0.26 0.28	2200 2500	60.0 67.0	1L255927132, Blue 1V224227012, Silver	2 1
	1H975927032, Orange	1.25 to 2.25 psig 1.25 to 3.25 psig	86 to 155 86 to 224	5.0 6.0	0.35 0.41	3000 3000	80.4 80.4	1V224227012, Silver 1V224227012, Silver	2 3

1. Flow of 0.6 specific gravity natural gas in SCFH at 60°F and 14.7 psia and Nm³/h at 0°C and 1.01325 bar.
2. See Figure 8 for specific performance curves by port diameter.

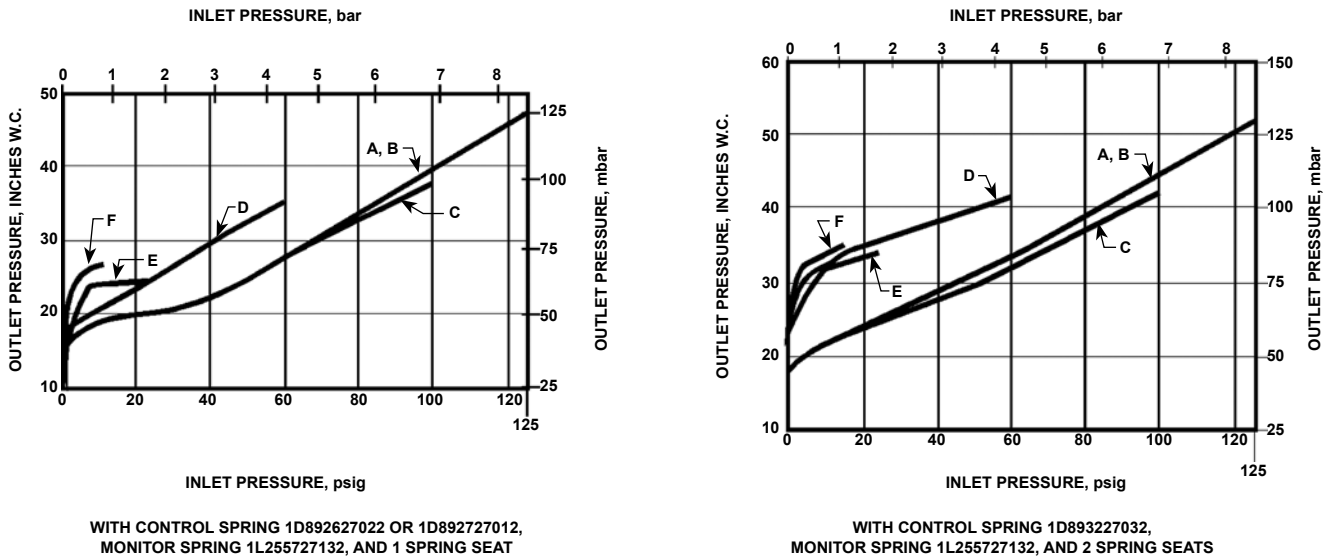

CURVE	PORT DIAMETER	
	Inches	mm
A	1/4	6.4
B	3/8	9.5
C	1/2	13
D	3/4	19
E	1	25
F	1-3/16	30

Figure 8. Integral Monitor Performance for Type S203 Regulator Blocked Wide Open and Venting Directly to Atmosphere

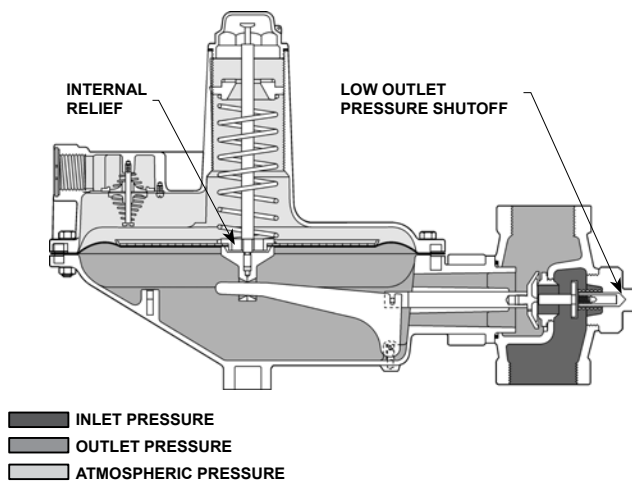

Figure 9. Type S206 Regulator with Low Outlet Pressure Shutoff and Internal Relief

Overpressuring any portion of a regulator or associated equipment may cause personal injury, leakage, or property damage due to bursting of pressure-containing parts or explosion of accumulated gas. Provide appropriate pressure relieving or pressure limiting devices to ensure that the limits in the Specifications or Table 4 are not exceeded. Regulator operation within ratings does not prevent the possibility of damage from external sources or from debris in the pipeline.

Refer to the relief sizing coefficients and the Capacity Information section to determine the required relief valve capacity.

Capacity Information

Tables 7 through 11 give the natural gas regulating capacities of S200 Series regulators at selected inlet pressures and outlet pressure settings. Flows are in SCFH (60°F and 14.7 psia) and Nm³/h (0°C and 1.01325 bar) of 0.6 specific gravity natural gas. To determine equivalent capacities for air, propane, butane, or nitrogen, multiply the SCFH table capacity by the following appropriate conversion factor: 0.775 for air, 0.628 for propane, 0.548 for butane, or 0.789 for nitrogen. For gases of other specific gravities, multiply the given capacity by 0.775, and divide by the square root of the appropriate specific gravity.

For Critical Pressure Drops—Use this equation (absolute outlet pressure equal to one-half or less than one-half the absolute inlet pressure).

$$Q = P_{1(\text{abs})} C_g (1.29)$$

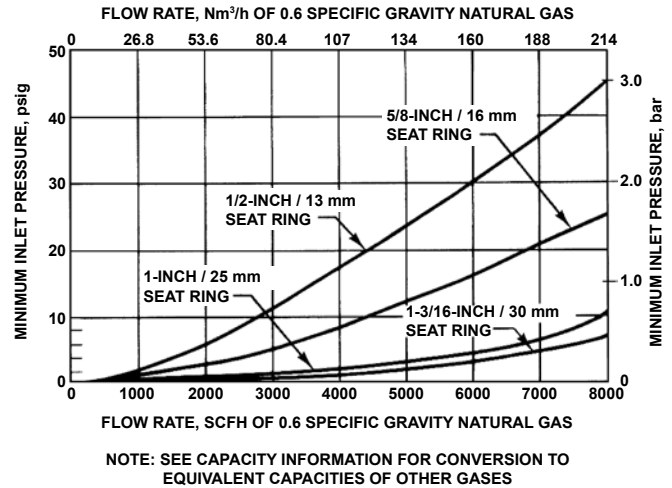

Figure 10. Minimum Inlet Pressure Required to Prevent Shutoff on all Sizes of Types S204, S204H, S206, and S206H Regulators at Indicated Flow

For Non-Critical Pressure Drops—Use this equation (absolute outlet pressure greater than one-half of absolute inlet pressure):

$$Q = \sqrt{\frac{520}{GT}} C_g P_1 \text{SIN} \left(\frac{3417}{C_1} \sqrt{\frac{\Delta P}{P_1}} \right) \text{DEG}$$

where:

- Q = gas flow rate, SCFH
- C_g = gas sizing coefficient
- P₁ = absolute inlet pressure, psia
- G = specific gravity of the gas
- T = absolute temperature of gas at inlet, °Rankine
- C₁ = flow coefficient
- ΔP = pressure drop across the regulator, psi

Installation

These regulators may be installed in any position. If gas escaping through the internal relief valve could constitute a hazard, the vent must be piped to a location where escaping gas will not be hazardous. In this case, obstruction-free tubing or piping of at least the same diameter as the vent size with a minimum number of bends should be used, and a screened vent should be installed on the end of the vent pipe. On all installations, the vent or the end of the vent pipe must be protected from anything that might clog it.

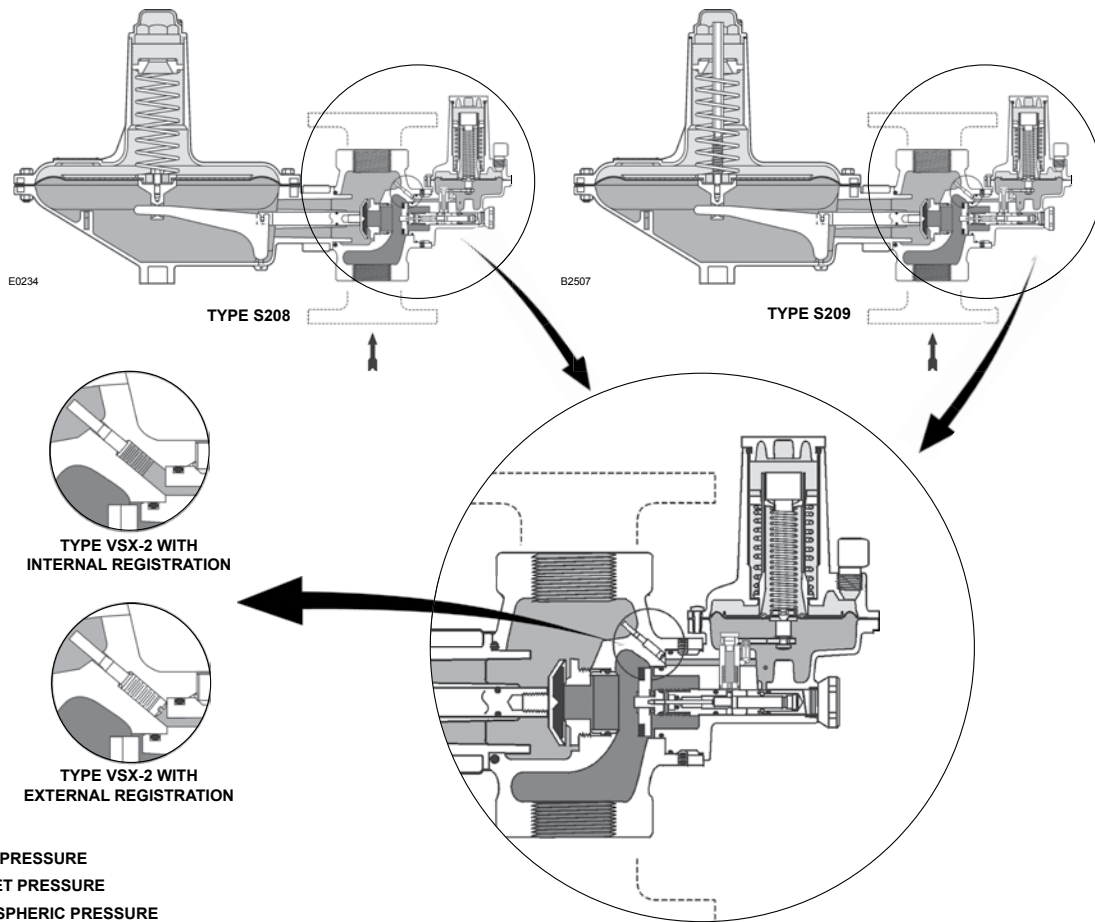

Figure 11. Type S208 Regulator with Type VSX-2 Slam-Shut Device (right) and Type S209 Regulator with Slam-Shut Device and Internal Token Relief (left)

Table 6. Type VSX-2 High and Low Trip Pressure Ranges



SETPOINT RANGES	SLAM-SHUT REGISTRATION	USE WITH MAIN VALVE SPRING NUMBERS ⁽¹⁾⁽²⁾	MINIMUM TO MAXIMUM TRIP PRESSURE		TYPE VSX-2 SPRING PART NUMBER	SPRING COLOR	SPRING FREE LENGTH		SPRING WIRE DIAMETER	
			Inches w.c.	mbar			Inches	mm	Inches	mm
Overpressure Shutoff	Internal or External	1, 2	12 to 25	30 to 62	T14162T0012	Black	3.15	80.0	0.067	1.70
		1, 2, 3, 4	20 to 52	50 to 129	T14163T0012	Brown	3.15	80.0	0.080	2.03
		3, 4, 5, 6	1.4 to 3.9 psig	0.10 to 0.27 bar	T14164T0012	Red	3.15	80.0	0.091	2.31
		5, 6, 7, 8, 9	3.8 to 8.7 psig	0.26 to 0.60 bar	T14165T0012	Orange	3.15	80.0	0.120	3.05
		9	5.8 to 16 psig	0.40 to 1.1 bar	T14166T0012	Pink	3.15	80.0	0.138	3.51
Underpressure Shutoff	External	2, 3	2 to 12	5 to 30	T14168T0012	White	3.15	80.0	0.043	1.09
		3, 4, 5, 6	4 to 30	10 to 75	T14169T0012	Blue	3.15	80.0	0.055	1.40
		5, 6, 7, 8	10 inches w.c. to 2.3 psig	25 mbar to 0.16 bar	T14170T0012	Silver	3.15	80.0	0.067	1.70
		7, 8, 9	1.5 to 10.8 psig	0.10 to 0.75 bar	T14171T0012	Olive	3.15	80.0	0.125	3.18
	Internal	2, 3, 4 ⁽³⁾	-----	-----	-----	-----	-----	-----	-----	-----
		5, 6 ⁽⁴⁾	50% of regulator setpoint to 30 inches w.c.	50% of regulator setpoint to 75 mbar	T14169T0012	Blue	3.15	80.0	0.055	1.40
		5, 6, 7, 8 ⁽⁴⁾	50% of regulator setpoint to 2.3 psig	50% of regulator setpoint to 0.16 bar	T14170T0012	Silver	3.15	80.0	0.067	1.70
		7, 8 ⁽⁴⁾	50% of regulator setpoint to 10.8 psig	50% of regulator setpoint to 0.75 bar	T14171T0012	Olive	3.15	80.0	0.125	3.18
		9 ⁽⁴⁾	70% of regulator setpoint to 10.8 psig	70% of regulator setpoint to 0.75 bar	T14171T0012	Olive	3.15	80.0	0.125	3.18

1. See Table 3 for main valve spring number.
 2. Other spring combinations are available, please contact your local Sales Office for additional information. Trip pressure that are 2 or 3 psig/ 0.14 to 0.21 bar over set pressure may result in internal parts damage.
 3. Regulator main valve spring numbers 2, 3, and 4 cannot be used with an internally registered Type VSX-2 to provide underpressure shutoff under flowing conditions. If protection against loss of inlet pressure is the only required function for the Type VSX-2 then an internally registered Type VSX-2 may be used with the same minimum trip pressure as an externally registered Type VSX-2.
 4. 50% of regulator setpoint is the minimum allowable underpressure shutoff setting for an internally registered Type VSX-2 used with main valve spring numbers 5, 6, 7, and 8. 70% of regulator setpoint is the minimum allowable underpressure shutoff setting for an internally registered Type VSX-2 used with main valve spring number 9. If the protection against loss of inlet pressure is the required function for the Type VSX-2 then an internally registered Type VSX-2 may be used with the same minimum trip pressure as an externally registered Type VSX-2.

Bulletin 71.1:S200

Table 7. Types S201, S202, S203, S208, and S209 Flow Capacities

OUTLET PRESSURE, SPRING PART NUMBER, AND ACCURACY	INLET PRESSURE		CAPACITIES IN SCFH / Nm ³ /h OF 0.6 SPECIFIC GRAVITY NATURAL GAS											
			NPS 1-1/2 / DN 40 Body Size											
			Orifice Size, Inches / mm											
			1/4 / 6.4		3/8 / 9.5		1/2 / 13		3/4 / 19		1 / 25		1-3/16 / 30	
			psig	bar	SCFH	Nm ³ /h	SCFH	Nm ³ /h	SCFH	Nm ³ /h	SCFH	Nm ³ /h	SCFH	Nm ³ /h
4 inches w.c. / 10 mbar 1D892527022 or 1D892627022 1 inch w.c. / 2 mbar droop 2 inches w.c. / 5 mbar boost	0.4	0.028						1000	26.8	1400	37.5	1600	42.8	
	0.5	0.034					1400	37.5	1600	42.8	1800	48.2		
	1	0.07	400	10.7	800	21.4	1200	32.2	2100	56.3	2500	67.0	2700	72.4
	1.5	0.10	500	13.4	1050	28.1	1600	42.9	2500	67.0	3000	80.4	3200	85.8
	2	0.14	600	16.1	1300	34.8	2100	56.3	2800	75.0	3500	93.8	3800	102
	5	0.34	1150	30.8	2200	58.9	3300	88.4	4500	121	5300	142	6000	161
	13	0.90	1600	42.8	3600	96.4	6200	166	7000	188	6000	161	6850	184
	25	1.7	2550	68.3	5000	134	7350	197	8950	240	9000	241		
	60	4.1	4750	127	5100	137	7050	189	5600 ⁽¹⁾	150 ⁽¹⁾				
	100	6.9	6650	178	7300	196	5200 ⁽¹⁾	139 ⁽¹⁾						
125	8.6	6950	186	8300	222									
7 inches w.c. / 17 mbar 1D892727012 1 inch w.c. / 2 mbar droop 2 inches w.c. / 5 mbar boost	0.4	0.028						900	24.1	1300	34.8	1450	38.9	
	0.5	0.034					1200	32.2	1550	41.5	1750	46.9		
	1	0.07	400	10.7	800	21.4	1100	29.5	1900	50.9	2300	61.6	2500	67.0
	1.5	0.10	500	13.4	1050	28.1	1500	40.2	2300	61.6	2800	75.0	1800	48.2
	2	0.14	600	16.1	1300	34.8	1900	50.9	2100	56.3	3300	88.4	1800	48.2
	5	0.34	950	25.5	2100	56.3	3200	85.8	3350	89.8	5100	137	4500	121
	13	0.90	1600	42.8	2200	58.9	3300	88.4	5800	155	8000	214	8000	214
	25	1.7	2200	58.9	5200	139	6800	182	8400	225	8750	235		
	60	4.1	4300	115	9200	247	10,100	271	9900	265				
	100	6.9	7500	201	10,500	281	9200 ⁽¹⁾	247 ⁽¹⁾						
125	8.6	9050	243	9800 ⁽¹⁾	263 ⁽¹⁾									
11 inches w.c. / 27 mbar 1D893227032 ± 2 inches w.c. / 5 mbar	0.5	0.03						800	21.4	1500	40.2	1700	45.6	
	1	0.07	400	10.7	700	18.7	1100	29.5	1800	48.2	2200	58.9	2450	65.7
	1.5	0.10	500	13.4	950	25.5	1450	38.9	2300	61.6	2800	75.0	2600	69.7
	2	0.14	600	16.1	1200	32.2	1700	45.6	1950	52.3	3200	85.8	2750	73.7
	5	0.34	950	25.5	2000	53.6	2900	77.7	3800	102	5100	137	5150	138
	13	0.90	1600	42.8	3400	91.1	3700	99.2	6100	163	7250	194	7650	205
	25	1.7	2100	56.3	5150	138	7100	190	7950	213	9400	252		
	60	4.1	4400	118	9250	248	9400	252	10,400	279				
	100	6.9	7300	196	10,000	268	10,100	271						
	125	8.6	9050	243	10,800	289								
14 inches w.c. / 35 mbar 1D893227032 ± 2 inches w.c. / 5 mbar	1	0.07	450	12.1	800	21.4	1000	26.8	1250	33.5	1500	40.2	1950	52.3
	1.5	0.10	500	13.4	850	22.8	1050	28.1	1550	41.5	1650	44.2	2350	62.9
	2	0.14	550	14.7	1150	30.8	1400	37.5	1750	46.9	2300	61.6	2500	67.0
	5	0.34	1000	26.8	1200	32.2	2050	54.9	3000	80.4	4300	115	4750	127
	13	0.90	1750	46.9	3050	81.7	4250	114	6100	163	7300	196	7850	210
	25	1.7	2500	67.0	4750	127	5650	151	8700	233	8700	233		
	60	4.1	4750	127	9450	253	9950	267	10,550	283				
	100	6.9	7450	200	10,400	279	10,600	284						
	125	8.6	9050	243	10,450	280								
	20 inches w.c. / 50 mbar 1D893327032 ± 3 inches w.c. / 7 mbar	1	0.07	300	8.04	500	13.4	750	20.1	1000	26.8	1300	34.8	1700
2		0.14	500	13.4	950	25.5	1400	37.5	2000	53.6	2800	75.0	3100	83.1
5		0.34	900	24.1	1700	45.6	2500	67.0	4200	113	5000	134	5500	147
13		0.90	1500	40.2	3200	85.8	5400	145	6500	174	7000	188	7100	190
25		1.7	2100	56.3	4700	126	7000	188	8250	221	9350	251		
60		4.1	4750	127	8900	239	9950	267	10,600	284				
100		6.9	7400	198	10,500	281	10,800	289						
125		8.6	9200	247	10,950	293								

1. Limited due to boost.
 - Shaded areas show where indicated droop would be exceeded regardless of capacity.
 - Shaded areas show where maximum operating inlet pressure for a given port diameter is exceeded.

- continued -

Table 7. Types S201, S202, S203, S208, and S209 Flow Capacities (continued)

OUTLET PRESSURE, SPRING PART NUMBER, AND ACCURACY	INLET PRESSURE		CAPACITIES IN SCFH / Nm ³ /h OF 0.6 SPECIFIC GRAVITY NATURAL GAS											
			NPS 2 / DN 50 Body Size											
			Orifice Size, Inches / mm											
			1/4 / 6.4		3/8 / 9.5		1/2 / 13		3/4 / 19		1 / 25		1-3/16 / 30	
psig	bar	SCFH	Nm ³ /h	SCFH	Nm ³ /h	SCFH	Nm ³ /h	SCFH	Nm ³ /h	SCFH	Nm ³ /h	SCFH	Nm ³ /h	
4 inches w.c. / 10 mbar 1D892527022 or 1D892627022 1 inch w.c. / 2 mbar droop 2 inches w.c. / 5 mbar boost	0.4	0.028						1200	32.2	1600	42.8	1800	48.2	
	0.5	0.034					1700	45.6	2200	58.9	2400	64.3		
	1	0.07	400	10.7	900	24.1	1300	34.8	2800	75.0	3200	85.8	3800	102
	1.5	0.10	500	13.4	1100	29.5	1700	45.6	3600	96.5	4300	115	5000	134
	2	0.14	600	16.1	1400	37.5	2200	58.9	4500	121	5500	147	6400	172
5 inches w.c. / 13 mbar 13 inches w.c. / 25 mbar	5	0.34	1000	26.8	2300	61.6	3700	99.2	7800	209	9500	255	12,700	340
	13	0.90	1650	44.2	3700	99.2	6500	174	13,000	348	14,000	375	14,500	389
	25	1.7	2400	64.3	5200	139	9200	247	13,000	348	18,000	482		
	60	4.1	4450	119	9000	241	14,550	390	15,000	402				
	100	6.9	5500	147	9500	255	12,900 ⁽¹⁾	346 ⁽¹⁾						
125	8.6	7250	194	3900 ⁽¹⁾	105 ⁽¹⁾									
7 inches w.c. / 17 mbar 1D892727012 1 inch w.c. / 2 mbar droop 2 inches w.c. / 5 mbar boost	0.4	0.028						950	25.5	1400	37.5	1600	42.8	
	0.5	0.034					1500	40.2	1800	48.2	2000	53.6		
	1	0.07	400	10.7	800	21.4	1200	32.2	2300	61.6	2800	75.0	3300	88.4
	1.5	0.10	500	13.4	1050	28.1	1600	42.8	3100	83.1	3600	96.5	4500	121
	2	0.14	600	16.1	1300	34.8	2000	53.6	4000	107	4500	121	6000	161
5 inches w.c. / 13 mbar 13 inches w.c. / 25 mbar	5	0.34	1000	26.8	2100	56.3	3500	93.8	7700	206	9400	252	9400	252
	13	0.90	1650	44.2	3500	93.8	6400	172	10,000	268	20,200	541	21,200	568
	25	1.7	2400	64.3	5200	139	10,300	276	20,000	536	11,800 ⁽¹⁾	316 ⁽¹⁾		
	60	4.1	4450	119	9000	241	12,000	322	20,700	555				
	100	6.9	7500	201	10,000	268	13,100	351						
125	8.6	9500	255	10,300	276									
11 inches w.c. / 27 mbar 1D893227032 ± 2 inches w.c. / 5 mbar	0.5	0.03						800	21.4	1500	40.2	1600	42.8	
	1	0.07	400	10.7	750	20.1	1100	29.5	1800	48.2	2500	67.0	2600	69.7
	1.5	0.10	500	13.4	1000	26.8	1450	38.9	2500	67.0	3400	91.1	3350	89.8
	2	0.14	600	16.1	1200	32.2	1700	45.6	3100	83.1	4200	113	3750	101
	5	0.34	1000	26.8	2000	53.6	3000	80.4	7300	196	7000	188	8500	228
± 2 inches w.c. / 5 mbar	13	0.90	1600	42.9	3400	91.1	6200	166	10,350	277	17,650	473	18,100	485
	25	1.7	2400	64.3	5650	151	10,350	277	19,300	517	23,450	628		
	60	4.1	4450	119	11,350	304	19,300	517	20,200	541				
	100	6.9	7450	200	16,650	446	20,200	541						
	125	8.6	9500	255	17,500	469								
14 inches w.c. / 35 mbar 1D893227032 ± 2 inches w.c. / 5 mbar	1	0.07	450	12.1	700	18.8	1100	29.5	1500	40.2	1700	45.6	2700	72.4
	1.5	0.10	550	14.7	850	22.8	1200	32.2	1900	50.9	2700	72.4	3600	96.5
	2	0.14	600	16.1	1000	26.8	1900	50.9	2800	75.0	3800	102	3800	102
	5	0.34	1050	28.1	1750	46.9	2800	75.0	4000	107	5300	142	10,600	284
	13	0.90	1750	46.9	3700	99.2	5700	153	14,400	386	18,000	482	18,500	496
± 2 inches w.c. / 5 mbar	25	1.7	2600	69.7	5700	153	10,200	273	18,000	482	25,400	681		
	60	4.1	4800	129	10,900	292	11,000	295	19,600	525				
	100	6.9	7400	198	16,500	442	14,100	378						
	125	8.6	9100	244	18,000	482								
20 inches w.c. / 50 mbar 1D893327032 ± 3 inches w.c. / 7 mbar	1	0.07	300	8.04	750	20.1	550	14.7	1250	33.5	1700	45.6	1800	48.2
	2	0.14	500	13.4	1150	30.8	1700	45.6	1900	50.9	2350	62.9	3250	87.1
	5	0.34	900	24.1	1650	44.2	2150	57.6	3250	87.1	6400	172	6700	180
	13	0.90	1500	40.2	2550	68.3	4350	117	5950	159	10,150	272	10,500	281
	25	1.7	2450	65.7	4850	130	7200	193	18,100	485	19,200	515		
± 3 inches w.c. / 7 mbar	60	4.1	4900	131	9400	252	19,600	525	22,700	608				
	100	6.9	7500	201	17,400	466	13,800	370						
	125	8.6	9150	245	5500 ⁽¹⁾	147 ⁽¹⁾								

1. Limited due to boost.

☐ - Shaded areas show where indicated droop would be exceeded regardless of capacity.

▒ - Shaded areas show where maximum operating inlet pressure for a given port diameter is exceeded.

- continued -

Bulletin 71.1:S200

Table 7. Types S201, S202, S203, S208, and S209 Flow Capacities (continued)

OUTLET PRESSURE, SPRING PART NUMBER, AND ACCURACY	INLET PRESSURE		CAPACITIES IN SCFH / Nm ³ /h OF 0.6 SPECIFIC GRAVITY NATURAL GAS												
			NPS 1-1/2 / DN 40 Body Size												
			Orifice Size, Inches / mm												
			1/4 / 6.4		3/8 / 9.5		1/2 / 13		3/4 / 19		1 / 25		1-3/16 / 30		
psig	bar	SCFH	Nm ³ /h	SCFH	Nm ³ /h	SCFH	Nm ³ /h	SCFH	Nm ³ /h	SCFH	Nm ³ /h	SCFH	Nm ³ /h		
1 psig / 0.07 bar 1D893337032 ± 0.2 psig / 0.014 bar	2	0.14	700	18.8	1250	33.5	1550	41.5	2900	77.7	3050	81.7	3250	87.1	
	5	0.34	1050	28.1	2150	57.6	2800	75.0	4800	129	5600	150	6300	169	
	10	0.69	1650	44.2	3200	85.8	4400	118	6550	176	7800	209	8150	218	
	15	1.0	2000	53.6	4100	110	5750	154	8000	214	9400	252	10,250	275	
	20	1.4	2300	61.6	4750	127	6100	163	8700	233	10,950	293			
	25	1.7	2600	69.7	5500	147	8200	220	9950	267	11,550	310			
	30	2.1	2900	77.7	6250	168	8350	224	10,800	289	12,250	328			
	40	2.7	3600	96.5	7500	201	9350	251	10,850	291					
	45	3.1	3900	105	8400	225	10,350	277	11,000	295					
	50	3.5	4250	114	8900	239	10,950	293	11,050	296					
	60	4.1	4950	133	10,000	268	11,000	295	11,400	306					
	80	5.5	6150	165	11,150	299	11,350	304							
	100	6.9	7500	201	12,000	322	12,000	322							
	125	8.6	9150	245	12,000	322									
	1 psig / 0.07 bar 1D893337032 ± 1 % ABS ± 0.16 psia / 0.011 bar	2	0.14	650	17.4	1050	28.1	1350	36.2	2450	65.7	2700	72.4	3000	80.4
		5	0.34	1050	28.1	2100	56.3	2700	72.4	3800	102	4700	126	5200	139
10		0.69	1500	40.2	2800	75.0	3700	99.2	5600	150	7000	188	7300	196	
15		1.0	1950	52.3	3750	101	4900	131	6900	185	8500	228	8750	235	
20		1.4	2200	58.9	4600	123	5800	155	8150	218	10,350	277			
25		1.7	2500	67.0	5000	134	7250	194	9050	243	10,850	291			
30		2.1	2800	75.0	6000	161	8200	220	9400	252	11,000	295			
40		2.8	3550	95.1	7350	197	9100	244	9500	255					
45		3.1	3900	105	8250	221	9650	259	10,100	271					
50		3.5	4050	109	8450	226	10,300	276	10,300	276					
60		4.1	4800	129	9050	243	10,450	280	10,550	283					
80		5.5	5900	158	11,000	295	11,000	297							
100		6.9	7400	198	11,150	299	11,150	299							
125		8.6	9000	241	11,750	315									
1 psig / 0.07 bar 1D893337032 ± 2 % ABS ± 0.31 psia / 0.021 bar		2	0.14	750	20.1	1450	38.9	2100	56.3	3700	99.2	4650	125	5350	143
		5	0.34	1250	33.5	2500	67.0	3550	95.1	6050	162	7900	212	7900	212
	10	0.69	1750	46.9	3450	92.5	5100	137	8550	229	9550	256	10,100	271	
	15	1.0	2050	54.9	4350	117	6700	180	9400	252	11,250	302	11,400	306	
	20	1.4	2500	67.0	5150	138	8100	217	10,500	281	12,200	327			
	25	1.7	2700	72.4	5800	155	10,100	271	11,550	310	12,600	338			
	30	2.1	3050	81.7	6650	178	10,550	283	12,350	331	13,100	351			
	40	2.8	3700	99.2	7950	213	10,550	283	12,350	331					
	45	3.1	4100	110	8800	236	11,800	316	12,700	340					
	50	3.5	4550	122	9250	248	12,000	322	13,000	348					
	60	4.1	5000	134	10,900	292	12,600	338	13,000	348					
	80	5.5	6450	173	12,550	336	13,000	348							
	100	6.9	7950	213	12,900	346	13,450	360							
	125	8.6	9450	253	13,450	360									
	1 psig / 0.07 bar 1H975827032 ± 0.2 psig / 0.014 bar	2	0.14	500	13.4	750	20.1	1750	46.9	2250	60.3	2400	64.3	2850	76.4
		5	0.34	1100	29.5	1800	48.2	2300	61.6	3400	91.1	4850	130	5350	143
10		1.03	1600	42.9	3200	85.8	4600	123	7250	194	8800	236	8800	236	
30		2.1	2800	75.0	6300	169	7800	209	10,400	279	11,250	302			
60		4.1	4900	131	9600	257	9650	259	11,000	295					
100		6.9	7300	196	11,200	300	11,950	320							
125		8.6	9100	244	10,550 ⁽¹⁾	283 ⁽¹⁾									

1. Limited due to boost.
 - Shaded areas show where indicated droop would be exceeded regardless of capacity.
 - Shaded areas show where maximum operating inlet pressure for a given port diameter is exceeded.

- continued -

Table 7. Types S201, S202, S203, S208, and S209 Flow Capacities (continued)



OUTLET PRESSURE, SPRING PART NUMBER, AND ACCURACY	INLET PRESSURE		CAPACITIES IN SCFH / Nm ³ /h OF 0.6 SPECIFIC GRAVITY NATURAL GAS											
			NPS 2 / DN 50 Body Size											
			Orifice Size, Inches / mm											
					1/4 / 6.4		3/8 / 9.5		1/2 / 13		3/4 / 19		1 / 25	
psig	bar	SCFH	Nm ³ /h	SCFH	Nm ³ /h	SCFH	Nm ³ /h	SCFH	Nm ³ /h	SCFH	Nm ³ /h	SCFH	Nm ³ /h	
1 psig / 0.07 bar 1D893337032 ± 0.2 psig / 0.014 bar	2	0.14	650	17.4	1200	32.2	2200	58.9	3200	85.8	3600	96.5	4500	121
	5	0.34	1100	29.5	2300	61.6	3200	85.8	4800	129	7700	206	10,000	268
	10	0.69	1600	42.9	3000	80.4	4300	115	11,400	306	15,200	407	16,300	437
	15	1.0	1900	50.9	4000	107	6900	185	15,600	418	20,800	557	22,300	598
	20	1.4	2300	61.6	4900	131	9100	244	19,000	509	24,000	643		
	25	1.7	2600	69.7	5600	150	10,500	281	21,700	582	27,400	734		
	30	2.1	2900	77.7	6500	174	11,800	316	25,300	678	32,800	879		
	40	2.8	3700	99.2	8000	214	14,500	389	27,000	724				
	45	3.1	4000	107	8800	236	15,800	423	27,000	724				
	50	3.5	4300	115	9300	249	16,600	445	28,000	750				
	60	4.1	4900	131	11,300	303	19,500	523	31,600	847				
	80	5.5	6300	169	14,200	381	24,000	643						
100	6.9	7700	206	16,700	448	29,500	791							
125	8.6	9600	257	20,200	541									
1 psig / 0.07 bar 1D893337032 ± 1 % ABS ± 0.16 psia / 0.011 bar	2	0.14	570	15.3	1100	29.5	2000	53.6	2750	73.7	3100	83.1	4000	107
	5	0.34	1050	28.1	2200	58.9	2750	73.7	4100	110	6250	168	9000	241
	10	0.69	1500	40.2	2500	67.0	4050	109	8500	228	13,250	355	13,700	367
	15	1.0	1900	50.9	3450	92.5	5800	155	15,500	415	16,000	429	16,300	437
	20	1.4	2300	61.6	4800	129	7700	206	18,300	490	20,850	559		
	25	1.7	2500	67.0	5600	150	10,400	279	21,500	576	22,800	611		
	30	2.1	2900	77.7	6350	170	11,950	320	23,800	638	24,300	651		
	40	2.8	3650	97.8	7850	210	14,550	390	24,300	651				
	45	3.1	3850	103	8400	225	15,600	418	25,400	681				
	50	3.5	4250	114	9350	251	16,700	448	26,000	697				
	60	4.1	4900	131	11,200	300	19,400	520	32,000	858				
	80	5.5	6200	166	14,250	382	24,600	659						
100	6.9	7400	198	16,750	449	29,000	777							
125	8.6	9350	251	20,200	541									
1 psig / 0.07 bar 1D893337032 ± 2 % ABS ± 0.31 psia / 0.021 bar	2	0.14	700	18.8	1450	38.9	2450	65.7	4100	110	5600	150	7900	212
	5	0.34	1150	30.8	2550	68.3	4000	107	8000	214	11,700	314	14,300	383
	10	0.69	1800	48.2	3550	95.1	6200	166	12,300	330	18,400	493	20,000	536
	15	1.0	2050	54.9	4450	119	7850	210	15,900	426	22,000	590	24,600	659
	20	1.4	2400	64.3	5250	141	9100	244	19,200	515	25,800	691		
	25	1.7	2750	73.7	5900	158	10,300	276	21,800	584	31,200	836		
	30	2.1	3150	84.4	6550	176	11,800	316	26,200	702	35,000	938		
	40	2.8	3750	101	8200	220	14,300	383	30,500	817				
	45	3.1	4050	109	8800	236	15,600	418	28,100	753				
	50	3.5	4400	118	9300	249	16,700	448	33,900	909				
	60	4.1	5050	135	10,850	291	19,500	523	34,200	917				
	80	5.5	6350	170	13,600	364	24,600	659						
100	6.9	7850	210	17,000	456	30,200	809							
125	8.6	9400	252	20,500	549									
1 psig / 0.07 bar 1H975827032 ± 0.2 psig / 0.014 bar	2	0.14	500	13.4	1050	28.1	1400	37.5	2200	58.9	2900	77.7	3700	99.2
	5	0.34	1100	29.5	2000	53.6	2200	58.9	4500	121	6600	177	7000	188
	10	1.03	1600	42.9	3500	93.8	5700	153	9700	260	13,000	348	13,300	356
	30	2.1	2800	75.0	6200	166	11,700	314	20,000	536	23,000	616		
	60	4.1	4900	131	10,900	292	19,300	517	20,600	552				
	100	6.9	7500	201	17,300	464	23,900	641						
	125	8.6	9000	241	19,900	533								

- Shaded areas show where indicated droop would be exceeded regardless of capacity.
 - Shaded areas show where maximum operating inlet pressure for a given port diameter is exceeded.

Bulletin 71.1:S200

Table 8. Types S201H, S202H, S203H, S208H, and S209H Capacities



OUTLET PRESSURE, SPRING PART NUMBER, AND ACCURACY	INLET PRESSURE		CAPACITIES IN SCFH / Nm ³ /h OF 0.6 SPECIFIC GRAVITY NATURAL GAS											
			NPS 1-1/2 / DN 40 Body Size											
			Orifice Size, Inches / mm											
			1/4 / 6.4		3/8 / 9.5		1/2 / 13		3/4 / 19		1 / 25		1-3/16 / 30	
psig	bar	SCFH	Nm ³ /h	SCFH	Nm ³ /h	SCFH	Nm ³ /h	SCFH	Nm ³ /h	SCFH	Nm ³ /h	SCFH	Nm ³ /h	
2 psig / 0.14 bar 1H975827032 ± 0.2 psig / 0.014 bar	5	0.34	850	22.8	1600	42.9	1650	44.2	2400	64.3	2450	65.7	3900	105
	10	0.69	1450	38.9	2050	54.9	3250	87.1	5400	145	5750	154	6650	178
	15	1.0	1650	44.2	3000	80.4	4300	115	7000	188	8200	220	8200	220
	20	1.4	2050	54.9	3850	103	5650	151	7500	201	9050	243		
	25	1.7	2500	67.0	4600	123	6500	174	9600	257	9700	260		
	30	2.1	2750	73.7	5650	151	6500	174	9600	257	10,850	291		
	40	2.8	3500	93.8	7000	188	8400	225	10,150	272				
	45	3.1	3750	101	7800	209	9150	245	10,500	281				
	50	3.5	4250	114	8500	228	9600	257	10,500	281				
	60	4.1	4850	130	8800	236	9700	260	11,400	306				
	80	5.5	6150	165	10,000	268	11,250	302						
	100	6.9	7600	204	10,800	289	11,250	302						
125	8.6	9300	249	12,200	327									
2 psig / 0.14 bar 1H975827032 ± 0.4 psig / 0.028 bar	5	0.34	1100	29.5	2200	58.9	2800	75.0	4550	122	5600	150	6550	176
	10	0.69	1750	46.9	3150	84.4	4600	123	7550	202	9050	243	10,150	272
	15	1.0	2000	53.6	4200	113	6400	172	10,050	269	11,000	295	11,200	300
	20	1.4	2400	64.3	5000	134	7550	202	11,700	314	12,200	327		
	25	1.7	2700	72.4	5750	154	9600	257	11,900	319	12,950	347		
	30	2.1	3100	83.1	6700	180	9600	257	11,900	319	13,300	356		
	40	2.8	3750	101	7950	213	10,750	288	13,000	348				
	45	3.1	4100	110	8750	235	10,750	288	13,000	348				
	50	3.5	4550	122	9550	256	12,700	340	13,000	348				
	60	4.1	5150	138	11,250	302	13,300	356	14,400	386				
	80	5.5	6450	173	12,750	342	13,300	356						
	100	6.9	7750	208	14,450	387	13,300	356						
125	8.6	9400	252	14,600	391									
2 psig / 0.14 bar 1H975827032 ± 1 % ABS ± 0.17 psia / 0.012 bar	5	0.34	850	22.8	1400	37.5	1450	38.9	2250	60.3	2450	65.7	3300	88.4
	10	0.69	1400	37.5	1650	44.2	2550	68.3	4350	117	5250	141	5600	150
	15	1.0	1500	40.2	2700	72.4	3800	102	6000	161	5400	145	8000	214
	20	1.4	2000	53.6	3600	96.5	5200	139	7200	193	8200	220		
	25	1.7	2400	64.3	4500	121	6400	172	9000	241	9550	256		
	30	2.1	2800	75.0	5600	150	7500	201	10,000	268	10,400	279		
	40	2.7	3600	96.5	7800	209	9200	247	10,150	272				
	45	3.1	3900	105	8400	225	9800	263	10,900	292				
	50	3.5	4300	115	9100	244	10,300	276	10,600	284				
	60	4.1	5000	134	10,200	273	11,400	306	11,300	303				
	80	5.5	6400	172	12,000	322	10,300 ⁽¹⁾	276 ⁽¹⁾						
	100	6.9	7900	212	13,000	348	11,150 ⁽¹⁾	299 ⁽¹⁾						
125	8.6	9600	257	11,950 ⁽¹⁾	320 ⁽¹⁾									
2 psig / 0.14 bar 1H975827032 ± 2 % ABS ± 0.33 psia / 0.023 bar	5	0.34	1050	28.1	2100	56.3	2500	67.0	4100	110	5200	139	6250	168
	10	0.69	1650	44.2	3050	81.7	4200	113	6400	172	8350	224	8850	237
	15	1.0	1900	50.9	4200	113	6200	166	8800	236	10,500	281	10,750	288
	20	1.4	2200	58.9	5100	137	7600	204	10,300	276	12,000	322		
	25	1.7	2500	67.0	5800	155	8700	233	11,800	316	12,050	323		
	30	2.1	3000	80.4	6500	174	9600	257	12,600	338	12,700	340		
	40	2.8	3600	96.5	8100	217	11,500	308	12,700	340				
	45	3.1	3900	105	8800	236	12,000	322	12,800	343				
	50	3.5	4300	115	9700	260	12,600	338	12,900	346				
	60	4.1	5000	134	11,300	303	13,600	364	13,700	367				
	80	5.5	6400	172	14,200	381	12,650	339						
	100	6.9	7900	212	15,500	415	12,950	347						
125	8.6	9600	257	14,200 ⁽¹⁾	381 ⁽¹⁾									

1. Limited due to boost.
 - Shaded areas show where indicated droop would be exceeded regardless of capacity.
 - Shaded areas show where maximum operating inlet pressure for a given port diameter is exceeded.

- continued -

Table 8. Types S201H, S202H, S203H, S208H, and S209H Capacities (continued)

OUTLET PRESSURE, SPRING PART NUMBER, AND ACCURACY	INLET PRESSURE		CAPACITIES IN SCFH / Nm ³ /h OF 0.6 SPECIFIC GRAVITY NATURAL GAS											
			NPS 2 / DN 50 Body Size											
			Orifice Size, Inches / mm											
			1/4 / 6.4		3/8 / 9.5		1/2 / 13		3/4 / 19		1 / 25		1-3/16 / 30	
psig	bar	SCFH	Nm ³ /h	SCFH	Nm ³ /h	SCFH	Nm ³ /h	SCFH	Nm ³ /h	SCFH	Nm ³ /h	SCFH	Nm ³ /h	
2 psig / 0.14 bar 1H975827032 ± 0.2 psig / 0.014 bar	5	0.34	850	22.8	1800	48.2	1800	48.2	2950	79.1	4250	114	5200	139
	10	0.69	1350	36.2	1900	50.9	3000	80.4	5200	139	6600	177	7800	209
	15	1.0	1700	45.6	2800	75.0	3700	99.2	6900	185	7200	193	9500	255
	20	1.4	2000	53.6	3800	102	5300	142	9000	241	9800	263		
	25	1.7	2450	65.7	4500	121	6800	182	12,500	335	14,200	381		
	30	2.1	2650	71.0	5200	139	7500	201	16,000	429	16,100	431		
	40	2.8	3400	91.1	7400	198	13,200	354	21,600	579				
	45	3.1	3600	96.5	8000	214	15,500	415	21,600	579				
	50	3.5	4000	107	8500	228	16,700	448	21,900	587				
	60	4.1	4600	123	10,700	287	19,200	515	18,800 ⁽¹⁾	504 ⁽¹⁾				
	80	5.5	5800	155	13,100	351	24,800	665						
	100	6.9	7100	190	16,200	434	25,600	686						
125	8.6	9000	241	19,900	533									
2 psig / 0.14 bar 1H975827032 ± 0.4 psig / 0.028 bar	5	0.34	1100	29.5	2250	60.3	3200	85.8	5500	147	7800	209	10,100	271
	10	0.69	1600	42.9	3250	87.1	5400	145	10,000	268	14,100	378	15,100	405
	15	1.0	2000	53.6	4150	111	7200	193	14,400	386	18,600	498	22,100	592
	20	1.4	2300	61.6	4950	133	9000	241	17,500	469	24,000	643		
	25	1.7	2650	71.0	5800	155	10,200	273	20,700	555	28,000	750		
	30	2.1	3100	83.1	6600	177	11,800	316	24,900	667	28,500	764		
	40	2.8	3600	96.5	8100	217	14,600	391	28,000	750				
	45	3.1	4100	110	8850	237	15,800	423	29,000	777				
	50	3.5	4400	118	9850	264	17,200	461	29,200	783				
	60	4.1	4900	131	11,300	303	19,500	523	29,300	785				
	80	5.5	6400	172	14,300	383	24,500	657						
	100	6.9	7600	204	17,200	461	29,700	796						
125	8.6	9400	252	20,500	549									
2 psig / 0.14 bar 1H975827032 ± 1 % ABS ± 0.17 psia / 0.012 bar	5	0.34	750	20.1	1600	42.9	1600	42.9	2400	64.3	3000	80.4	4100	110
	10	0.69	1250	33.5	1600	42.9	2550	68.3	4250	114	5000	134	6100	163
	15	1.0	1600	42.9	2700	72.4	3800	102	5200	139	6900	185	7600	204
	20	1.4	2000	53.6	3600	96.5	5200	139	6900	185	9400	252		
	25	1.7	2450	65.7	4400	118	7500	201	9600	257	10,650	285		
	30	2.1	2800	75.0	5200	139	8600	230	11,800	316	16,100	431		
	40	2.8	3700	99.2	7500	201	12,200	327	16,200	434				
	45	3.1	4100	110	8400	225	15,200	407	18,350	492				
	50	3.5	4400	118	9000	241	16,900	453	21,000	563				
	60	4.1	5100	137	11,000	295	20,800	557	21,000	563				
	80	5.5	6500	174	14,600	391	24,800	665						
	100	6.9	8000	214	18,000	482	29,300	785						
125	8.6	9800	263	20,500	549									
2 psig / 0.14 bar 1H975827032 ± 2 % ABS ± 0.33 psia / 0.023 bar	5	0.34	1000	26.8	2150	57.6	2750	73.7	5000	134	6200	166	7900	212
	10	0.69	1550	41.5	3050	81.7	5000	134	8600	230	12,750	342	13,800	370
	15	1.0	1900	50.9	4200	113	7200	193	11,000	295	11,750	315	21,700	582
	20	1.4	2300	61.6	5100	137	9200	247	14,200	381	16,000	429		
	25	1.7	2600	69.7	5900	158	10,700	287	16,400	440	25,400	681		
	30	2.1	3000	80.4	6600	177	12,100	324	19,700	528	27,900	748		
	40	2.8	3700	99.2	8200	220	12,200	327	27,200	729				
	45	3.1	4100	110	9000	241	15,200	407	27,200	729				
	50	3.5	4400	118	9700	260	16,900	453	27,400	734				
	60	4.1	5100	137	11,300	303	20,800	557	27,400	734				
	80	5.5	6500	174	14,600	391	24,500	657						
	100	6.9	8000	214	18,000	482	29,600	793						
125	8.6	9800	263	20,500	549									



1. Limited due to boost.
 - Shaded areas show where indicated droop would be exceeded regardless of capacity.
 - Shaded areas show where maximum operating inlet pressure for a given port diameter is exceeded.

- continued -

Bulletin 71.1:S200

Table 8. Types S201H, S202H, S203H, S208H, and S209H Capacities (continued)



OUTLET PRESSURE, SPRING PART NUMBER, AND ACCURACY	INLET PRESSURE		CAPACITIES IN SCFH / Nm ³ /h OF 0.6 SPECIFIC GRAVITY NATURAL GAS											
			NPS 1-1/2 / DN 40 Body Size											
			Orifice Size, Inches / mm											
			1/4 / 6.4		3/8 / 9.5		1/2 / 13		3/4 / 19		1 / 25		1-3/16 / 30	
psig	bar	SCFH	Nm ³ /h	SCFH	Nm ³ /h	SCFH	Nm ³ /h	SCFH	Nm ³ /h	SCFH	Nm ³ /h	SCFH	Nm ³ /h	
3 psig / 0.21 bar 1H975927032 ± 0.3 psig / 0.021 bar	5	0.34	800	21.4	1350	36.2	1650	44.2	2500	67.0	2500	67.0	3850	103
	10	0.69	1200	32.2	1800	48.2	2650	71.0	4600	123	6050	162	6600	177
	15	1.0	1650	44.2	2300	61.6	3750	101	6500	174	9200	247	8200	220
	20	1.4	1950	52.3	3500	93.8	5000	134	8350	224	9200	247		
	25	1.7	2150	57.6	4400	118	6500	174	8150	218	10,050	269		
	30	2.1	2700	72.4	5600	150	6700	180	10,050	269	11,250	302		
	40	2.8	3300	88.4	6900	185	7900	212	10,300	276				
	45	3.1	3550	95.1	7000	188	8650	232	11,000	295				
	50	3.5	4050	109	7800	209	9700	260	11,000	295				
	60	4.1	4250	114	8200	220	9900	265	11,450	307				
	80	5.5	5950	159	10,000	268	11,600	311						
	100	6.9	7450	200	11,750	315	11,900	319						
125	8.6	8800	236	12,200	327									
3 psig / 0.21 bar 1H975927032 ± 0.6 psig / 0.041 bar	5	0.34	1100	29.5	1950	52.3	2800	75.0	4250	114	5400	145	7200	193
	10	0.69	1650	44.2	3100	83.1	4650	125	7750	208	8700	233	9100	244
	15	1.0	2050	54.9	4100	110	5950	159	9550	256	11,150	299	11,800	316
	20	1.4	2400	64.3	4900	131	7800	209	10,650	285	12,350	331		
	25	1.7	2600	69.7	5750	154	8700	233	11,950	320	14,050	377		
	30	2.1	3100	83.1	6550	176	10,250	275	12,050	323	14,400	386		
	40	2.8	3150	84.4	7850	210	11,300	303	13,800	370				
	45	3.1	4150	111	8400	225	12,450	334	14,150	379				
	50	3.5	4400	118	9300	249	12,450	334	14,150	379				
	60	4.1	5000	134	10,700	287	13,000	348	15,350	411				
	80	5.5	6400	172	13,050	350	16,000	429						
	100	6.9	7650	205	15,400	413	16,050	430						
125	8.6	9200	247	16,050	430									
3 psig / 0.21 bar 1H975927032 ± 1 % ABS ± 0.18 psig / 0.012 bar	5	0.34	500	13.4	1150	30.8	1200	32.2	1450	38.9	1550	41.5	2100	56.3
	10	0.69	900	24.1	1350	36.2	1500	40.2	2750	73.7	3200	85.8	3400	91.1
	15	1.0	1200	32.2	1700	45.6	2200	58.9	3900	105	4900	131	4950	133
	20	1.4	1500	40.2	2100	56.3	2900	77.7	5300	142	8000	214		
	25	1.7	1900	50.9	2600	69.7	4300	115	7400	198	9350	251		
	30	2.1	2200	58.9	3100	83.1	5100	137	8400	225	8650 ⁽¹⁾	232 ⁽¹⁾		
	40	2.8	2900	77.7	4800	129	8000	214	8750	235				
	45	3.1	3300	88.4	5800	155	9300	249	9900	265				
	50	3.5	3700	99.2	6800	182	10,200	273	10,600	284				
	60	4.1	4400	118	8400	225	11,600	311	10,700	287				
	80	5.5	6300	169	10,800	289	9400 ⁽¹⁾	252 ⁽¹⁾						
	100	6.9	8100	217	12,100	324	11,750	315						
125	8.6	10,000	268	10,750 ⁽¹⁾	288 ⁽¹⁾									
3 psig / 0.21 bar 1H975927032 ± 2 % ABS ± 0.35 psia / 0.024 bar	5	0.34	900	24.1	1450	38.9	1800	48.2	3000	80.4	3000	80.4	4650	125
	10	0.69	1250	33.5	2050	54.9	3150	84.4	5150	138	6450	173	6650	178
	15	1.0	1800	48.2	3100	83.1	4400	118	7200	193	8700	233	8700	233
	20	1.4	2200	58.9	3800	102	6100	163	8600	230	11,000	295		
	25	1.7	2600	69.7	5000	134	7600	204	9700	260	11,050	296		
	30	2.1	2900	77.7	5800	155	8700	233	11,200	300	11,450	307		
	40	2.8	3600	96.5	7800	209	10,800	289	11,600	311				
	45	3.1	4000	107	8400	225	11,600	311	11,600	311				
	50	3.5	4600	123	9400	252	12,400	332	11,750	315				
	60	4.1	5100	137	10,600	284	13,800	370	13,250	355				
	80	5.5	6500	174	12,700	340	12,600 ⁽¹⁾	338 ⁽¹⁾						
	100	6.9	8100	217	14,400	386	12,550 ⁽¹⁾	336 ⁽¹⁾						
125	8.6	10,000	268	12,500 ⁽¹⁾	335 ⁽¹⁾									

1. Limited due to boost.
 - Shaded areas show where indicated droop would be exceeded regardless of capacity.
 - Shaded areas show where maximum operating inlet pressure for a given port diameter is exceeded.

- continued -

Table 8. Types S201H, S202H, S203H, S208H, and S209H Capacities (continued)

OUTLET PRESSURE, SPRING PART NUMBER, AND ACCURACY	INLET PRESSURE		CAPACITIES IN SCFH / Nm ³ /h OF 0.6 SPECIFIC GRAVITY NATURAL GAS											
			NPS 2 / DN 50 Body Size											
			Orifice Size, Inches / mm											
			1/4 / 6.4		3/8 / 9.5		1/2 / 13		3/4 / 19		1 / 25		1-3/16 / 30	
psig	bar	SCFH	Nm ³ /h	SCFH	Nm ³ /h	SCFH	Nm ³ /h	SCFH	Nm ³ /h	SCFH	Nm ³ /h	SCFH	Nm ³ /h	
3 psig / 0.21 bar 1H975927032 ± 0.3 psig / 0.021 bar	5	0.34	750	20.1	1400	37.5	1600	42.9	2400	64.3	2900	77.7	3500	93.8
	10	0.69	1200	32.2	1900	50.9	2750	73.7	5000	134	6400	171	6900	185
	15	1.0	1400	37.5	2000	53.6	3100	83.1	5900	158	7700	206	9800	263
	20	1.4	1850	49.6	3000	80.4	4150	111	7700	206	7900	212		
	25	1.7	2050	54.9	3900	105	5000	134	9100	244	9750	261		
	30	2.1	2550	68.3	4800	129	6700	180	10,100	271	17,200	461		
	40	2.8	3150	84.4	6250	168	8700	233	11,600	311				
	45	3.1	3400	91.1	6750	181	9900	265	14,500	389				
	50	3.5	3900	105	6750	181	12,300	330	13,900	373				
	60	4.1	4350	117	9400	252	12,700	340	18,300	490				
	80	5.5	5600	150	12,700	340	18,800	504						
	100	6.9	7000	188	14,800	397	18,800	504						
125	8.6	8650	232	18,800	504									
3 psig / 0.21 bar 1H975927032 ± 0.6 psig / 0.041 bar	5	0.34	1100	29.5	1950	52.3	2550	68.3	4700	126	6000	161	7450	200
	10	0.69	1550	41.5	3000	80.4	4750	127	8600	230	12,200	327	15,400	413
	15	1.0	2050	54.9	3850	103	5950	159	12,600	338	16,200	434	20,300	544
	20	1.4	2400	64.3	4850	130	8200	220	17,000	456	21,800	584		
	25	1.7	2800	75.0	5750	154	9800	263	19,700	528	23,000	616		
	30	2.1	3150	84.4	6450	173	11,600	311	22,500	603	26,500	710		
	40	2.8	3650	97.8	7850	210	14,300	383	26,400	708				
	45	3.1	4100	110	8900	239	15,500	415	28,500	764				
	50	3.5	4350	117	9450	253	17,000	456	29,600	793				
	60	4.1	5100	137	11,100	297	19,850	532	29,900	801				
	80	5.5	6350	170	14,350	385	25,200	675						
	100	6.9	7250	194	17,250	462	29,400	788						
125	8.6	9400	252	21,000	563									
3 psig / 0.21 bar 1H975927032 ± 1 % ABS ± 0.18 psia / 0.012 bar	5	0.34	650	17.4	1100	29.5	790	21.2	1500	40.2	1700	45.6	1750	46.9
	10	0.69	1000	26.8	1250	33.5	1500	40.2	2500	67.0	3700	99.2	4300	115
	15	1.0	1250	33.5	1750	46.9	2000	53.6	2900	77.7	3750	101	6000	161
	20	1.4	1450	38.9	2400	64.3	2200	58.9	4100	110	5750	154		
	25	1.7	1600	42.8	2900	77.7	4000	107	6900	185	6400	172		
	30	2.1	1950	52.3	3550	95.1	4400	118	8700	233	6700	180		
	40	2.8	2700	72.4	3850	103	5500	147	6450	173				
	45	3.1	2900	77.7	5400	145	9000	241	8000	214				
	50	3.5	3300	88.4	5700	153	9100	244	7900	212				
	60	4.1	3900	105	7200	193	11,500	308	10,300	276				
	80	5.5	5250	141	9200	247	9800 ⁽¹⁾	263 ⁽¹⁾						
	100	6.9	6250	168	11,300	303	10,900 ⁽¹⁾	292 ⁽¹⁾						
125	8.6	7750	208	12,650	339									
3 psig / 0.21 bar 1H975927032 ± 2 % ABS ± 0.35 psia / 0.024 bar	5	0.34	800	21.4	1450	38.9	1700	45.6	3150	84.4	3250	87.1	4000	107
	10	0.69	1300	34.8	2150	57.6	3200	85.8	5550	149	7200	193	9000	241
	15	1.0	1550	41.5	2850	76.4	4050	109	6800	182	8250	221	10,800	289
	20	1.4	1850	49.6	3300	88.4	5400	145	9300	249	10,900	292		
	25	1.7	2350	62.9	4650	125	6700	180	11,250	302	15,600	418		
	30	2.1	2450	65.7	5100	137	8600	230	12,250	328	17,350	465		
	40	2.8	3150	84.4	6950	186	11,400	306	15,150	406				
	45	3.1	3400	91.1	7650	205	11,900	319	18,150	486				
	50	3.5	3800	102	8500	228	14,000	375	20,200	541				
	60	4.1	4300	115	9850	264	19,000	509	21,150	567				
	80	5.5	5500	147	12,600	338	23,100	619						
	100	6.9	6500	174	15,500	415	23,650	634						
125	8.6	8100	217	20,650	553									

1. Limited due to boost.
 - Shaded areas show where indicated droop would be exceeded regardless of capacity.
 - Shaded areas show where maximum operating inlet pressure for a given port diameter is exceeded.

- continued -

Bulletin 71.1:S200

Table 8. Types S201H, S202H, S203H, S208H, and S209H Capacities (continued)

OUTLET PRESSURE, SPRING PART NUMBER, AND ACCURACY	INLET PRESSURE		CAPACITIES IN SCFH / Nm ³ /h OF 0.6 SPECIFIC GRAVITY NATURAL GAS											
			NPS 1-1/2 / DN 40 Body Size											
			Orifice Size, Inches / mm											
			1/4 / 6.4		3/8 / 9.5		1/2 / 13		3/4 / 19		1 / 25		1-3/16 / 30	
psig	bar	SCFH	Nm ³ /h	SCFH	Nm ³ /h	SCFH	Nm ³ /h	SCFH	Nm ³ /h	SCFH	Nm ³ /h	SCFH	Nm ³ /h	
5 psig / 0.34 bar 1P615427142 ± 0.5 psig / 0.034 bar	10	0.69	1200	32.2	1850	49.6	2300	61.6	3350	89.8	4750	127	5500	147
	15	1.0	1350	36.2	2450	65.7	3200	85.8	5250	141	6650	178	7550	202
	20	1.4	1850	49.6	3200	85.8	3900	105	6700	180	8600	230		
	25	1.7	2200	58.9	3600	96.5	4900	131	8250	221	10,000	268		
	30	2.1	2500	67.0	5100	137	6500	174	8800	236	11,450	307		
	40	2.8	3250	87.1	6100	163	7650	205	10,650	285				
	45	3.1	3650	97.8	6950	186	8500	228	11,200	300				
	50	3.5	3850	103	7550	202	9250	248	12,250	328				
	60	4.1	4600	123	8550	229	10,300	276	12,950	347				
	80	5.5	5900	158	10,550	283	12,500	335						
	100	6.9	7250	194	12,000	322	12,550	336						
	125	8.6	9000	241	13,300	356								
5 psig / 0.34 bar 1P615427142 ± 1 psig / 0.69 bar	10	0.69	1550	41.5	2850	76.4	4050	109	6450	173	8450	226	9800	263
	15	1.0	2000	53.6	3850	103	5800	155	9250	248	11,150	299	12,400	332
	20	1.4	2450	65.7	4750	127	7150	192	11,400	306	13,250	355		
	25	1.7	2800	75.0	5700	153	8600	230	12,800	343	15,250	409		
	30	2.1	3100	83.1	6400	172	10,050	269	13,550	363	16,800	450		
	40	2.8	3700	99.2	7850	210	12,350	331	15,650	419				
	45	3.1	4050	109	8600	230	13,000	348	15,950	427				
	50	3.5	4450	119	9400	252	13,650	366	16,300	437				
	60	4.1	5050	135	10,700	287	15,100	405	18,200	488				
	80	5.5	6300	169	13,400	359	17,650	473						
	100	6.9	7600	204	15,950	427	17,650	473						
	125	8.6	9200	247	17,800	477								
5 psig / 0.34 bar 1P615427142 ± 1 % ABS ± 0.20 psia / 0.014 bar	10	0.69	650	17.4	900	24.1	1050	28.1	1200	32.2	1950	52.3	2200	58.9
	15	1.0	800	21.4	1100	29.5	1500	40.2	2000	53.6	2600	69.7	3400	91.1
	20	1.4	1050	28.1	1400	37.5	2050	54.9	2800	75.0	3800	102		
	25	1.7	1200	32.2	1800	48.2	2350	62.9	3800	102	4400	118		
	30	2.1	1450	38.9	2200	58.9	3000	80.4	4900	131	5250	141		
	40	2.8	1950	52.3	2950	79.1	4400	118	5750	154				
	45	3.1	2200	58.9	3300	88.4	5000	134	6550	176				
	50	3.5	2400	64.3	3850	103	6200	166	8200	220				
	60	4.1	2950	79.1	4800	129	8400	225	9250	248				
	80	5.5	4000	107	7400	198	7800	209						
	100	6.9	5300	142	10,700	287	9200	247						
	125	8.6	7200	193	6150 ⁽¹⁾	165 ⁽¹⁾								
5 psig / 0.34 bar 1P615427142 ± 2 % ABS ± 0.39 psia / 0.028 bar	10	0.69	1050	28.1	1650	44.2	1950	52.3	2600	69.7	3700	99.2	4900	131
	15	1.0	1350	36.2	2050	54.9	2900	77.7	4300	115	5600	150	6350	170
	20	1.4	1750	46.9	2700	72.4	3900	105	5800	155	7400	198		
	25	1.7	2100	56.3	3350	89.8	4850	130	7300	196	8750	235		
	30	2.1	2400	64.3	4050	109	5750	154	8700	233	10,150	272		
	40	2.8	3200	85.8	5300	142	8000	214	9800	263				
	45	3.1	3500	93.8	6050	162	8950	240	10,750	288				
	50	3.5	3900	105	6800	182	9800	263	11,000	295				
	60	4.1	4700	126	8400	225	11,500	308	12,100	324				
	80	5.5	6150	165	11,100	297	10,300 ⁽¹⁾	276 ⁽¹⁾						
	100	6.9	7900	212	13,100	351	11,200 ⁽¹⁾	300 ⁽¹⁾						
	125	8.6	9700	260	11,950 ⁽¹⁾	320 ⁽¹⁾								

1. Limited due to boost.
 - Shaded areas show where indicated droop would be exceeded regardless of capacity.
 - Shaded areas show where maximum operating inlet pressure for a given port diameter is exceeded.

- continued -

Table 8. Types S201H, S202H, S203H, S208H, and S209H Capacities (continued)

OUTLET PRESSURE, SPRING PART NUMBER, AND ACCURACY	INLET PRESSURE		CAPACITIES IN SCFH / Nm ³ /h OF 0.6 SPECIFIC GRAVITY NATURAL GAS											
			NPS 2 / DN 50 Body Size											
			Orifice Size, Inches / mm											
			1/4 / 6.4		3/8 / 9.5		1/2 / 13		3/4 / 19		1 / 25		1-3/16 / 30	
psig	bar	SCFH	Nm ³ /h	SCFH	Nm ³ /h	SCFH	Nm ³ /h	SCFH	Nm ³ /h	SCFH	Nm ³ /h	SCFH	Nm ³ /h	
5 psig / 0.34 bar 1P615427142 ± 0.5 psig / 0.034 bar	10	0.69	1200	32.2	1700	45.6	2200	58.9	3750	101	5300	142	5800	155
	15	1.0	1400	37.5	2100	56.3	2850	76.4	5500	147	6850	184	8150	218
	20	1.4	1800	48.2	2850	76.4	3750	101	7000	188	7700	206		
	25	1.7	2050	54.9	3750	101	4550	122	7900	212	9750	261		
	30	2.1	2500	67.0	4550	122	5800	155	8500	228	10,750	288		
	40	2.8	3150	84.4	5800	155	6200	166	12,000	322				
	45	3.1	3500	93.8	6200	166	7000	188	12,850	344				
	50	3.5	3900	105	7000	188	7700	206	14,200	381				
	60	4.1	4350	117	7700	206	10,950	293	16,650	446				
	80	5.5	5850	157	10,950	293	13,500	362						
	100	6.9	7150	192	13,500	362	16,400	440						
	125	8.6	8900	239	16,400	440								
5 psig / 0.34 bar 1P615427142 ± 1 psig / 0.69 bar	10	0.69	1500	40.2	2800	75.0	4050	109	7350	197	9400	252	12,400	332
	15	1.0	2050	54.9	3950	106	5700	153	10,750	288	12,950	347	17,100	458
	20	1.4	2400	64.3	4750	127	7300	196	13,550	363	18,450	494		
	25	1.7	2750	73.7	5450	146	9100	244	16,200	434	20,400	547		
	30	2.1	3100	83.1	6500	174	10,500	281	19,200	515	24,700	662		
	40	2.8	3750	101	7850	210	13,700	367	25,250	677				
	45	3.1	4050	109	8550	229	15,150	406	25,700	689				
	50	3.5	4400	118	9600	257	16,650	446	27,950	749				
	60	4.1	4950	133	10,850	291	19,150	513	30,550	819				
	80	5.5	6450	173	14,000	375	24,150	647						
	100	6.9	7700	206	17,000	456	29,400	788						
	125	8.6	9250	248	20,700	555								
5 psig / 0.34 bar 1P615427142 ± 1 % ABS ± 0.20 psia / 0.014 bar	10	0.69	500	13.4	850	22.8	1000	26.8	1500	40.2	2000	53.6	2200	58.9
	15	1.0	750	20.1	1200	32.2	1400	37.5	1900	50.9	2300	61.6	2900	77.7
	20	1.4	1000	26.8	1550	41.5	1900	50.9	2700	72.4	3000	80.4		
	25	1.7	1250	33.5	1950	52.3	2300	61.6	3400	91.1	3700	99.2		
	30	2.1	1450	38.9	2200	58.9	2800	75.0	4100	110	4000	107		
	40	2.8	1900	50.9	3100	83.1	4000	107	3300	88.4				
	45	3.1	2100	56.3	3400	91.1	4400	118	4600	123				
	50	3.5	2400	64.3	3800	102	5000	134	5300	142				
	60	4.1	2800	75.0	4700	126	6600	177	7250	194				
	80	5.5	3900	105	7300	196	5050 ⁽¹⁾	135 ⁽¹⁾						
	100	6.9	5000	134	9300	249	6400 ⁽¹⁾	172 ⁽¹⁾						
	125	8.6	7000	188	6000 ⁽¹⁾	161 ⁽¹⁾								
5 psig / 0.34 bar 1P615427142 ± 2 % ABS ± 0.39 psia / 0.028 bar	10	0.69	1000	26.8	1400	37.5	1650	44.2	2900	77.7	3500	93.8	4500	121
	15	1.0	1300	34.8	2100	56.3	2800	75.0	3900	105	5500	147	5850	157
	20	1.4	1650	44.2	2750	73.7	3600	96.5	5300	142	7400	198		
	25	1.7	2050	54.9	3400	91.1	4400	118	6800	182	7400	198		
	30	2.1	2400	64.3	4000	107	5500	147	7900	212	8350	224		
	40	2.8	3100	83.1	5400	145	7200	193	9300	249				
	45	3.1	3250	87.1	6100	163	8300	222	9850	264				
	50	3.5	3850	103	6700	180	9400	252	10,650	285				
	60	4.1	4450	119	8200	220	11,500	308	14,550	390				
	80	5.5	6100	163	11,000	295	10,850 ⁽¹⁾	291 ⁽¹⁾						
	100	6.9	7600	204	14,000	375	11,800	316						
	125	8.6	9600	257	11,650 ⁽¹⁾	312 ⁽¹⁾								

1. Limited due to boost.
 - Shaded areas show where indicated droop would be exceeded regardless of capacity.
 - Shaded areas show where maximum operating inlet pressure for a given port diameter is exceeded.

Bulletin 71.1:S200

Table 9. Types S201K and S208K Capacities

OUTLET PRESSURE, SPRING PART NUMBER, AND ACCURACY	INLET PRESSURE		CAPACITIES IN SCFH / Nm ³ /h OF 0.6 SPECIFIC GRAVITY NATURAL GAS											
			Orifice Size, Inches / mm											
			1/4 / 6.4		3/8 / 9.5		1/2 / 13		3/4 / 19		1 / 25		1-3/16 / 30	
			psig	bar	SCFH	Nm ³ /h	SCFH	Nm ³ /h	SCFH	Nm ³ /h	SCFH	Nm ³ /h	SCFH	Nm ³ /h
5 psig / 0.34 bar 0Y066427022 ± 0.5 psig / 0.034 bar	10	0.69	500	13.4	1000	26.8	1250	33.5	1900	50.9	2150	57.6	2550	68.3
	15	1.0	550	14.7	1300	34.8	1650	44.2	2650	71.0	3200	85.8	4000	107
	20	1.4	600	16.1	1650	44.2	1950	52.3	3300	88.4	4100	110	5000	134
	25	1.7	800	21.4	1950	52.3	2150	57.6	3950	106	4650	125		
	30	2.1	1600	42.9	2150	57.6	2650	71.0	4500	121	5500	147		
	40	2.8	1950	52.3	2650	71.0	2900	77.7	5800	155				
	45	3.1	2250	60.3	2900	77.7	3450	92.5	6200	166				
	50	3.5	2450	65.7	3450	92.5	3800	102	6600	177				
	60	4.1	2600	69.7	3800	102	5350	143	8700	233				
	80	5.5	3700	99.2	5350	143	5900	158						
	100	6.9	4100	110	5900	158	7950	213						
	125	8.6	5450	146	7950	213								
5 psig / 0.34 bar 0Y066427022 ± 1 psig / 0.69 bar	10	0.69	1150	30.8	1700	45.6	2250	60.3	3400	91.1	4550	122	5650	151
	15	1.0	1300	34.8	2550	68.3	3150	84.4	5200	139	6350	170	8100	217
	20	1.4	1900	50.9	2950	79.1	3950	106	6000	161	8300	222	9950	267
	25	1.7	2200	58.9	3650	97.8	4850	130	7050	189	9950	267		
	30	2.1	2650	71.0	4000	107	5500	147	8750	235	11,750	315		
	40	2.8	3100	83.1	5000	134	6900	185	10,850	291				
	45	3.1	3450	92.5	5800	155	7650	205	11,700	314				
	50	3.5	3800	102	6450	173	8900	239	14,100	378				
	60	4.1	4400	118	7450	200	9800	263	14,900	399				
	80	5.5	5950	159	9300	249	12,000	322						
	100	6.9	7000	188	11,250	302	14,750	395						
	125	8.6	8450	226	13,800	370								
5 psig / 0.34 bar 0Y066427022 ± 1 % ABS ± 0.20 psia / 0.014 bar	10	0.69	350	9.38	400	10.7	650	17.4	800	21.4	1050	28.1	1300	34.8
	15	1.0	350	9.38	750	20.1	850	22.8	1250	33.5	1550	41.5	1650	44.2
	20	1.4	500	13.4	900	24.1	1050	28.1	1650	44.2	1800	48.2	2050	54.9
	25	1.7	600	16.1	1000	26.8	1200	32.2	1650	44.2	1950	52.3		
	30	2.1	700	18.8	1100	29.5	1300	34.8	1950	52.3	2550	68.3		
	40	2.8	1000	26.8	1350	36.2	1350	36.2	2450	65.7				
	45	3.1	1100	29.5	1450	38.9	1550	41.5	2550	68.3				
	50	3.5	1150	30.8	1600	42.9	1600	42.9	3050	81.7				
	60	4.1	1150	30.8	1750	46.9	2250	60.3	2400 ⁽¹⁾	64.3 ⁽¹⁾				
	80	5.5	1600	42.9	2350	62.9	2750	73.7						
	100	6.9	1650	44.2	2400	64.3	3250	87.1						
	125	8.6	2150	57.6	3050	81.7								
5 psig / 0.34 bar 0Y066427022 ± 2 % ABS ± 0.39 psia / 0.028 bar	10	0.69	450	12.1	450	12.1	1100	29.5	1500	40.2	1700	45.6	2250	60.3
	15	1.0	450	12.1	1150	30.8	1500	40.2	2150	57.6	2500	67.0	3300	88.4
	20	1.4	550	14.7	1400	37.5	1700	45.6	2800	75.0	3350	89.8	3900	105
	25	1.7	1250	33.5	1650	44.2	2050	54.9	3050	81.7	4200	113		
	30	2.1	1350	36.2	1850	49.6	2500	67.0	3750	101	4350	117		
	40	2.8	1700	45.6	2200	58.9	2900	77.7	4700	126				
	45	3.1	1800	48.2	2350	62.9	3500	93.8	5200	139				
	50	3.5	1900	50.9	2850	76.4	3850	103	5900	158				
	60	4.1	2100	56.3	2900	77.7	4300	115	6900	185				
	80	5.5	3100	83.1	4050	109	5500	147						
	100	6.9	3400	91.1	4800	129	6050	162						
	125	8.6	4400	118	5750	154								

1. Limited due to boost.
 - Shaded areas show where indicated droop would be exceeded regardless of capacity.
 - Shaded areas show where maximum operating inlet pressure for a given port diameter is exceeded.

- continued -

Table 9. Types S201K and S208K Capacities (continued)

OUTLET PRESSURE, SPRING PART NUMBER, AND ACCURACY	INLET PRESSURE		CAPACITIES IN SCFH / Nm ³ /h OF 0.6 SPECIFIC GRAVITY NATURAL GAS											
			NPS 1-1/2 and 2 / DN 50 Body Sizes											
			Orifice Size, Inches / mm											
			1/4 / 6.4		3/8 / 9.5		1/2 / 13		3/4 / 19		1 / 25		1-3/16 / 30	
			psig	bar	SCFH	Nm ³ /h	SCFH	Nm ³ /h	SCFH	Nm ³ /h	SCFH	Nm ³ /h	SCFH	Nm ³ /h
10 psig / 0.69 bar 1H802400A2 ± 1 psig / 0.069 bar	10	0.69	550	14.7	800	21.4	1050	28.1	1200	32.2	1350	36.2	1750	46.9
	15	1.0	700	18.8	1200	32.2	1650	44.2	2500	67.0	2950	79.1	3800	102
	20	1.4	800	21.4	1650	44.2	2100	56.3	3150	84.4	4450	119	5350	143
	25	1.7	1500	40.2	2000	53.6	2750	73.7	4350	117	4900	131	6500	174
	30	2.1	1850	49.6	2300	61.6	3000	80.4	4850	130	6200	166		
	40	2.8	2150	57.6	3050	81.7	4100	110	6400	172				
	45	3.1	2300	61.6	3400	91.1	4600	123	7150	192				
	50	3.5	2500	67.0	3950	106	5100	137	7650	205				
	60	4.1	2900	77.7	4350	117	6000	161	8550	229				
	80	5.5	3900	105	5950	159	7550	202						
	100	6.9	4650	125	6800	182	9650	259						
	125	8.6	5300	142	8200	220								
10 psig / 0.69 bar 1H802400A2 ± 2 psig / 0.14 bar	10	0.69	950	25.5	1600	42.9	2450	65.7	3550	95.1	3600	96.5	4250	114
	15	1.0	1550	41.5	2350	62.9	2900	77.7	4900	131	6450	173	7600	204
	20	1.4	1900	50.9	3000	80.4	4000	107	6700	180	9000	241	10,400	279
	25	1.7	2300	61.6	3800	102	5250	141	8150	218	10,300	276	13,050	350
	30	2.1	2750	73.7	4750	127	6000	161	9700	260	12,200	327		
	40	2.8	3400	91.1	5850	157	7550	202	12,250	328				
	45	3.1	3650	97.8	6300	169	8800	236	13,650	366				
	50	3.5	3950	106	7250	194	9300	249	15,100	405				
	60	4.1	4650	125	8150	218	11,000	295	16,650	446				
	80	5.5	5850	157	10,750	288	13,750	369						
	100	6.9	7250	194	12,850	344	17,100	458						
	125	8.6	8700	233	15,750	422								
10 psig / 0.69 bar 1H802400A2 ± 1 % ABS ± 1.5 psia / 0.10 bar	10	0.69	300	8.04	400	10.7	350	9.38	400	10.7	400	10.7	450	12.1
	15	1.0	350	9.38	450	12.1	650	17.4	750	20.1	850	22.8	1100	29.5
	20	1.4	350	9.38	650	17.4	700	18.8	900	24.1	1350	36.2	1350	36.2
	25	1.7	450	12.1	800	21.4	950	25.5	1200	32.2	1500	40.2	1900	50.9
	30	2.1	700	18.8	900	24.1	1050	28.1	1200	32.2	1900	50.9		
	40	2.8	700	18.8	1100	29.5	1150	30.8	1850	49.6				
	45	3.1	750	20.1	1100	29.5	1300	34.8	2100	56.3				
	50	3.5	800	21.4	1200	32.2	1300	34.8	2300	61.6				
	60	4.1	850	22.8	1300	34.8	1450	38.9	2300	61.6				
	80	5.5	950	25.5	1600	42.9	1600	42.9						
	100	6.9	1050	28.1	1950	52.3	2600	69.7						
	125	8.6	1050	28.1	2350	62.9								
10 psig / 0.69 bar 1H802400A2 ± 2 % ABS ± 2.9 psia / 0.20 bar	10	0.69	400	10.7	500	13.4	650	17.4	900	24.1	650	17.4	900	24.1
	15	1.0	450	12.1	550	14.7	850	22.8	1300	34.8	1550	41.5	1850	49.6
	20	1.4	450	12.1	1000	26.8	1100	29.5	1750	46.9	2200	58.9	2400	64.3
	25	1.7	550	14.7	1250	33.5	1600	42.9	2300	61.6	2700	72.4	3550	95.1
	30	2.1	800	21.4	1350	36.2	1800	48.2	2800	75.0	2800	75.0		
	40	2.8	1050	28.1	1650	44.2	2150	57.6	3500	93.8				
	45	3.1	1350	36.2	1900	50.9	2600	69.7	3700	99.2				
	50	3.5	1450	38.9	2100	56.3	2850	76.4	4300	115				
	60	4.1	1600	42.9	2300	61.6	3100	83.1	4400	118				
	80	5.5	2150	57.6	3000	80.4	4000	107						
	100	6.9	2450	65.7	3700	99.2	4950	133						
	125	8.6	2600	69.7	4450	119								

- Shaded areas show where indicated droop would be exceeded regardless of capacity.
 - Shaded areas show where maximum operating inlet pressure for a given port diameter is exceeded.

Bulletin 71.1:S200

Table 10. Types S201P, S202P, S203P, S208P, and S209P Capacities

OUTLET PRESSURE, SPRING PART NUMBER, AND ACCURACY	INLET PRESSURE		CAPACITIES IN SCFH / Nm ³ /h OF 0.6 SPECIFIC GRAVITY NATURAL GAS												
			NPS 1-1/2 and 2 / DN 40 and 50 Body Sizes												
			Orifice Size, Inches / mm												
			1/4 / 6.4		3/8 / 9.5		1/2 / 13		3/4 / 19		1 / 25		1-3/16 / 30		
			psig	bar	SCFH	Nm ³ /h	SCFH	Nm ³ /h	SCFH	Nm ³ /h	SCFH	Nm ³ /h	SCFH	Nm ³ /h	SCFH
6 inches w.c. / 15 mbar 1D892627022 ± 1 inch w.c. / 2.5 mbar	0.4	0.028							1200	32.2	1500	40.2	1750	46.9	
	0.5	0.034							1600	42.9	1900	50.9	2200	59.0	
	1.0	0.069	400	10.7	900	24.1	1300	34.8	2300	61.6	2900	77.7	3300	88.4	
	1.5	0.10	500	13.4	1150	30.8	1650	44.2	3000	80.4	3600	96.5	4300	115	
	2.0	0.14	600	16.1	1400	37.5	2000	53.6	3500	93.8	4200	113	5500	147	
	5.0	0.34	1000	26.8	2300	61.6	3500	93.8	5700	153	7300	196	7700	206	
	13	0.90	1650	44.2	3700	99.2	6200	166	10,000	268	13,500	362	13,500	362	
	25	1.7	2400	64.3	5200	139	9000	241	13,500	362	13,500	362			
	60	4.1	4400	118	9600	257	13,500	362	13,500	362					
	100	6.9	7000	188	13,500	362	13,500	362							
125	8.6	7000	188	13,500	362										
7 inches w.c. / 17 mbar 1D892727012 ± 1 inch w.c. / 2.5 mbar	0.4	0.028							950	25.5	1350	36.2	1550	41.5	
	0.5	0.034							1500	40.2	1700	45.6	1950	52.3	
	1.0	0.069	400	10.7	800	21.4	1200	32.2	2000	53.6	2600	69.7	3000	80.4	
	1.5	0.10	500	13.4	1050	28.1	1500	40.2	2550	68.3	3200	85.8	4100	110	
	2.0	0.14	600	16.1	1300	34.8	1800	48.2	3000	80.4	3700	99.2	5000	134	
	5.0	0.34	1000	26.8	2100	56.3	3100	83.1	5000	134	6500	174	7000	188	
	13	0.90	1650	44.2	3300	88.4	5500	147	8600	230	12,000	322	13,500	362	
	25	1.7	2400	64.3	5000	134	8000	214	13,500	362	13,500	362			
	60	4.1	4400	118	9400	252	13,500	362	13,500	362					
	100	6.9	7000	188	13,500	362	13,500	362							
125	8.6	7000	188	13,500	362										
11 inches w.c. / 27 mbar 1D893227032 ± 2 inches w.c. / 5 mbar	0.5	0.034							1450	38.9	1650	44.2	1850	49.6	
	1.0	0.069	375	10.1	750	20.1	1100	29.5	1800	48.2	2500	67.0	2900	77.7	
	1.5	0.10	475	12.7	1000	26.8	1450	38.9	2400	64.3	3100	83.1	3900	105	
	2.0	0.14	550	14.7	1250	33.5	1700	45.6	3000	80.4	3600	96.5	4800	129	
	5.0	0.34	950	25.5	2000	53.6	2900	77.7	4800	129	6500	174	6700	180	
	13	0.90	1550	41.5	3100	83.1	5100	137	9000	241	11,000	295	13,500	362	
	25	1.7	2260	60.6	4700	126	8000	214	13,500	362	13,500	362			
	60	4.1	4200	113	8900	239	13,500	362	13,500	362					
	100	6.9	6600	177	13,500	362	13,500	362							
	125	8.6	6600	177	13,500	362									
20 inches w.c. / 50 mbar 1D893327032 ± 3 inches w.c. / 7.5 mbar	1.0	0.069	300	8.04	500	13.4	950	25.5	1000	26.8	1300	34.8	2000	53.6	
	2.0	0.14	500	13.4	950	25.5	1500	40.2	2000	53.6	2900	77.7	4000	107	
	5.0	0.34	850	22.8	1700	45.6	2400	64.3	4000	107	5000	134	5300	142	
	13	0.90	1350	36.2	2800	75.0	4400	118	6500	174	8700	233	13,500	362	
	25	1.7	2000	53.6	4800	129	6600	177	10,000	268	13,500	362			
	60	4.1	3700	99.2	9000	241	12,700	340	13,500	362					
	100	6.9	6000	161	13,500	362	13,500	362							
	125	8.6	6000	161	13,500	362									
	1 psig / 0.069 bar 1H975827032 ± 0.2 psig / 0.014 bar	2.0	0.14	500	13.4	750	20.1	1100	29.5	1400	37.5	2400	64.3	3000	80.4
		6.0	0.41	1100	29.5	1800	48.2	2500	67.0	4000	107	5200	139	7000	188
14		0.97	1500	40.2	3000	80.4	4500	121	7000	188	9000	241	13,500	362	
30		2.1	2300	61.6	4800	129	7000	188	11,000	295	13,500	362			
60		4.1	4400	118	9200	247	10,500	281	13,500	362					
100		6.9	7000	188	13,500	362	13,500	362							
125		8.6	7000	188	13,500	362									
3 psig / 0.21 bar 1H975927032 ± 0.6 psig / 0.041 bar		3.0	0.21	500	13.4	1000	26.8	1500	40.2	2000	53.6	3200	85.8	3600	96.5
		7.0	0.48	1000	26.8	2200	59.0	3400	91.1	5700	153	7000	188	8800	236
		14	0.97	1500	40.2	3000	80.4	5700	153	10,000	268	11,000	295	13,500	362
	30	2.1	2400	64.3	5000	134	7500	201	13,500	362	13,500	362			
	60	4.1	4300	115	9400	252	11,500	308	13,500	362					
	100	6.9	6800	182	11,400	306	13,500	362							
	125	8.6	6800	182	11,400	306									



1. Type S203P is limited to 2 psig / 0.14 bar.

◻ – Shaded areas indicate where droop would be exceeded regardless of capacity.

◼ – Shaded areas indicate where maximum operating inlet pressure for a given orifice size is exceeded.

Table 11. Types S204, S204H, S206, and S206H Capacities

TYPE	OUTLET PRESSURE, SPRING PART NUMBER, AND ACCURACY	INLET PRESSURE		CAPACITIES IN SCFH / Nm ³ /h OF 0.6 SPECIFIC GRAVITY NATURAL GAS										
				NPS 1-1/2 / DN 40 Body Size										
				Orifice Size, inches / mm										
				3/8 / 9.5		1/2 / 13		5/8 / 16		1 / 25		1-3/16 / 30		
psig	bar	SCFH	Nm ³ /h	SCFH	Nm ³ /h	SCFH	Nm ³ /h	SCFH	Nm ³ /h	SCFH	Nm ³ /h			
S204 and S206	5 inches w.c. / 12 mbar 1D892527022 or 1D892627022	0.5	0.034							1400	37.5	1700	45.6	
		1.0	0.069							2200	59.0	2300	61.6	
		2.0	0.14							3000	80.4	3200	85.8	
		5.0	0.34					3000	80.4	3850	103	4100	110	
		7	0.48			2000	53.6	3500	93.8	4100	110	4400	118	
		15	1.03	1200	32.2	3400	91.1	3800	102	4600	123	4600	123	
	± 1 inch w.c. / 2.5 mbar	20	1.4	1500	40.2	3800	102	4300	115	4800	129			
		30	2.1	1900	50.9	4000	107	4600	123	4900	131			
		60	4.1	3000	80.4	4700	126	5100	137					
		75	5.2	3800	102	5500	147	5800	155					
		100	6.9	4800	129	7000	188							
	7 inches w.c. / 17 mbar 1D892727012	0.5	0.034							1400	37.5	1600	42.9	
		1.0	0.069							2200	59.0	2300	61.6	
		2.0	0.14							2700	72.4	3000	80.4	
		5.0	0.34					3000	80.4	3700	99.2	3900	105	
		7	0.48			2000	53.6	3500	93.8	3900	105	4100	110	
		15	1.0	1200	32.2	3400	91.1	3800	102	4400	118	4600	123	
	± 1 inch w.c. / 2.5 mbar	20	1.4	1500	40.2	3800	102	4300	115	4600	123			
		30	2.1	1900	50.9	4000	107	4500	121	4700	126			
		60	4.1	3000	80.4	4700	126	5100	137					
		75	5.2	3800	102	5000	134	5200	139					
		100	6.9	4800	129	7000	188							
11 inches w.c. / 27 mbar 1D893227032	0.5	0.034							1000	26.8	1100	29.5		
	1.0	0.069							1700	45.6	2000	53.6		
	2.0	0.14							2700	72.4	3000	80.4		
	5.0	0.34					2800	75.0	4100	110	4500	121		
	7	0.48			2000	53.6	3000	80.4	4600	123	5000	134		
	15	1.0	1200	32.2	3400	91.1	4400	118	5200	139	5400	145		
± 2 inches w.c. / 5 mbar	20	1.4	1400	37.5	4000	107	5000	134	5800	155				
	30	2.1	1800	48.2	5300	142	5800	155	6400	172				
	60	4.1	3000	80.4	6100	164	6700	180						
	75	5.2	3600	96.5	6800	182	7400	198						
	100	6.9	4500	121	8400	225								
20 inches w.c. / 50 mbar 1D893327032	1.0	0.069							1600	42.9	1750	46.9		
	2.0	0.14							2600	69.7	2800	75.0		
	5.0	0.34					2500	67.0	4000	107	4300	115		
	7	0.48			2000	53.6	3100	83.1	4500	121	4700	126		
	15	1.0	1100	29.5	3400	91.1	4400	118	5500	147	5900	158		
	20	1.4	1300	34.8	4000	107	5000	134	6000	161				
± 3 inches w.c. / 7.5 mbar	30	2.1	1700	45.6	5200	139	5900	158	6800	182				
	60	4.1	3000	80.4	6700	180	7300	196						
	75	5.2	3500	93.8	7750	208	7750	208						
	100	6.9	4400	118	8800	236								
S204H and S206H	1 psig / 0.069 bar 1H975827032	2	0.14							1600	42.9	1900	50.9	
		5	0.34							4000	107	4500	121	
		8	0.55			2000	53.6	2400	64.3	4900	131	5500	147	
		15	1.0	1200	32.2	3400	91.1	4400	118	6300	169	7000	188	
		20	1.4	1400	37.5	3800	102	5000	134	6900	185			
	± 0.2 psi / 0.014 bar	30	2.1	1800	48.2	5300	142	6200	166	8300	222			
		60	4.1	3000	80.4	7400	198	8800	236					
		75	5.2	3600	96.5	8500	228	9500	255					
		100	6.9	4600	123	9600	257							
	3 psig / 0.21 bar 1H975927032	3	0.21							1800	48.2	2100	56.3	
		5	0.34							4000	107	5000	134	
		8	0.55			2600	69.7	3000	80.4	6000	161	8000	214	
		15	1.0	1200	32.2	3900	105	4800	129	9000	241	10,000	268	
		20	1.4	1400	37.5	4600	123	5900	158	10,500	281			
± 0.6 psi / 0.041 bar	30	2.1	1900	50.9	6900	185	8000	214	13,000	348				
	60	4.1	3100	83.1	9000	241	11,000	295						
	75	5.2	3800	102	10,000	268	14,000	375						
	100	6.9	4800	129	11,500	308								

 - Shaded areas indicate where droop would be exceeded regardless of capacity.
 - Shaded areas indicate where maximum operating inlet pressure for a given orifice size is exceeded.

- continued -

Bulletin 71.1:S200

Table 11. Types S204, S204H, S206, and S206H Capacities (continued)

TYPE	OUTLET PRESSURE, SPRING PART NUMBER, AND ACCURACY	INLET PRESSURE		CAPACITIES IN SCFH / Nm ³ /h OF 0.6 SPECIFIC GRAVITY NATURAL GAS										
				NPS 1-1/2 / DN 40 Body Size										
				Orifice Size, Inches / mm										
				3/8 / 9.5		1/2 / 13		5/8 / 16		1 / 25		1-3/16 / 30		
				psig	bar	SCFH	Nm ³ /h	SCFH	Nm ³ /h	SCFH	Nm ³ /h	SCFH	Nm ³ /h	SCFH
S204 and S206	5 inches w.c. / 12 mbar 1D892527022 or 1D892627022	0.5	0.034							1400	37.5	1800	48.2	
		1.0	0.069							2400	64.3	2800	75.0	
		2.0	0.14							3500	93.8	3800	102	
		5.0	0.34							4000	107	4200	113	
		7	0.48			2100	56.3	3600	96.5	4300	115	4500	121	
		15	1.0	1200	32.2	3500	93.8	4000	107	4800	129	5000	134	
		20	1.4	1500	40.2	4000	107	4500	121	5000	134			
		30	2.1	1900	50.9	4200	113	4800	129	5000	134			
		60	4.1	3200	85.8	4900	131	5300	142					
		75	5.2	3900	105	5800	155	6000	161					
	100	6.9	4900	131	7200	193								
	7 inches w.c. / 17 mbar 1D892727012	0.5	0.034								1400	37.5	1700	45.6
		1.0	0.069								2400	64.3	2700	72.4
		2.0	0.14								3400	91.1	3700	99.2
		5.0	0.34							3000	80.4	3900	105	
		7	0.48			2100	56.3	3600	96.5	4000	107	4200	113	
		15	1.0	1200	32.2	3500	93.8	4000	107	4500	121	4700	126	
		20	1.4	1500	40.2	4000	107	4500	121	4700	126			
		30	2.1	1900	50.9	4200	113	4700	126	4800	129			
		60	4.1	3200	85.8	4900	131	5300	142					
		75	5.2	3900	105	5700	153	5400	145					
	100	6.9	4900	131	7200	193								
	11 inches w.c. / 27 mbar 1D893227032	0.5	0.034								1100	29.5	1400	37.5
		1.0	0.069								2100	56.3	2500	67.0
2.0		0.14								3500	93.8	3900	105	
5.0		0.34							2800	75.0	4500	121		
7		0.48			2000	53.6	3100	83.1	4900	131	5200	139		
15		1.0	1200	32.2	3500	93.8	4500	121	5400	145	5500	147		
20		1.4	1400	37.5	4000	107	5200	139	6000	161				
30		2.1	1800	48.2	5400	145	6000	161	6500	174				
60		4.1	3000	80.4	6200	166	6800	182						
75		5.2	3600	96.5	7000	188	7500	201						
100	6.9	4500	121	8800	236									
20 inches w.c. / 50 mbar 1D893327032	1.0	0.069								1600	42.9	1750	46.9	
	2.0	0.14								2700	72.4	3200	85.8	
	5.0	0.34							2500	67.0	4100	110		
	7	0.48			2000	53.6	3100	83.1	4600	123	4800	129		
	15	1.0	1100	29.5	3500	93.8	4500	121	5800	155	6000	161		
	20	1.4	1300	34.8	4000	107	5200	139	6200	166				
	30	2.1	1700	45.6	5400	145	6000	161	7000	188				
	60	4.1	3000	80.4	6900	185	7700	206						
	75	5.2	3500	93.8	7750	208	7750	208						
	100	6.9	4400	118	9500	255								
S204H and S206H	1 psig / 0.069 bar 1H975827032	2	0.14							1800	48.2	2100	56.3	
		5	0.34							2000	53.6	4200	113	
		8	0.55			2000	53.6	2400	64.3	5200	139	6000	161	
		15	1.0	1200	32.2	3500	93.8	4500	121	6500	174	7500	201	
		20	1.4	1400	37.5	4000	107	5200	139	7200	193			
		30	2.1	1800	48.2	5500	147	6500	174	8500	228			
	± 0.2 psi / 0.014 bar	60	4.1	3000	80.4	7500	201	9200	247					
		75	5.2	3600	96.5	9000	241	10,000	268					
		100	6.9	4600	123	10,000	268							
		3	0.21							2000	53.6	2500	67.0	
		5	0.34							4500	121	5500	147	
		8	0.55			2600	69.7	3100	83.1	7000	188	8400	225	
	3 psig / 0.21 bar 1H975927032	15	1.0	1200	32.2	4000	107	5000	134	10,000	268	13,000	348	
		20	1.4	1400	37.5	4700	126	6200	166	12,000	322			
		30	2.1	1900	50.9	7000	188	8500	228	16,000	429			
		60	4.1	3100	83.1	9200	247	13,000	348					
		75	5.2	3800	102	12,000	322	16,000	429					
		100	6.9	4800	129	13,500	362							

- Shaded areas indicate where droop would be exceeded regardless of capacity.
 - Shaded areas indicate where maximum operating inlet pressure for a given orifice size is exceeded.

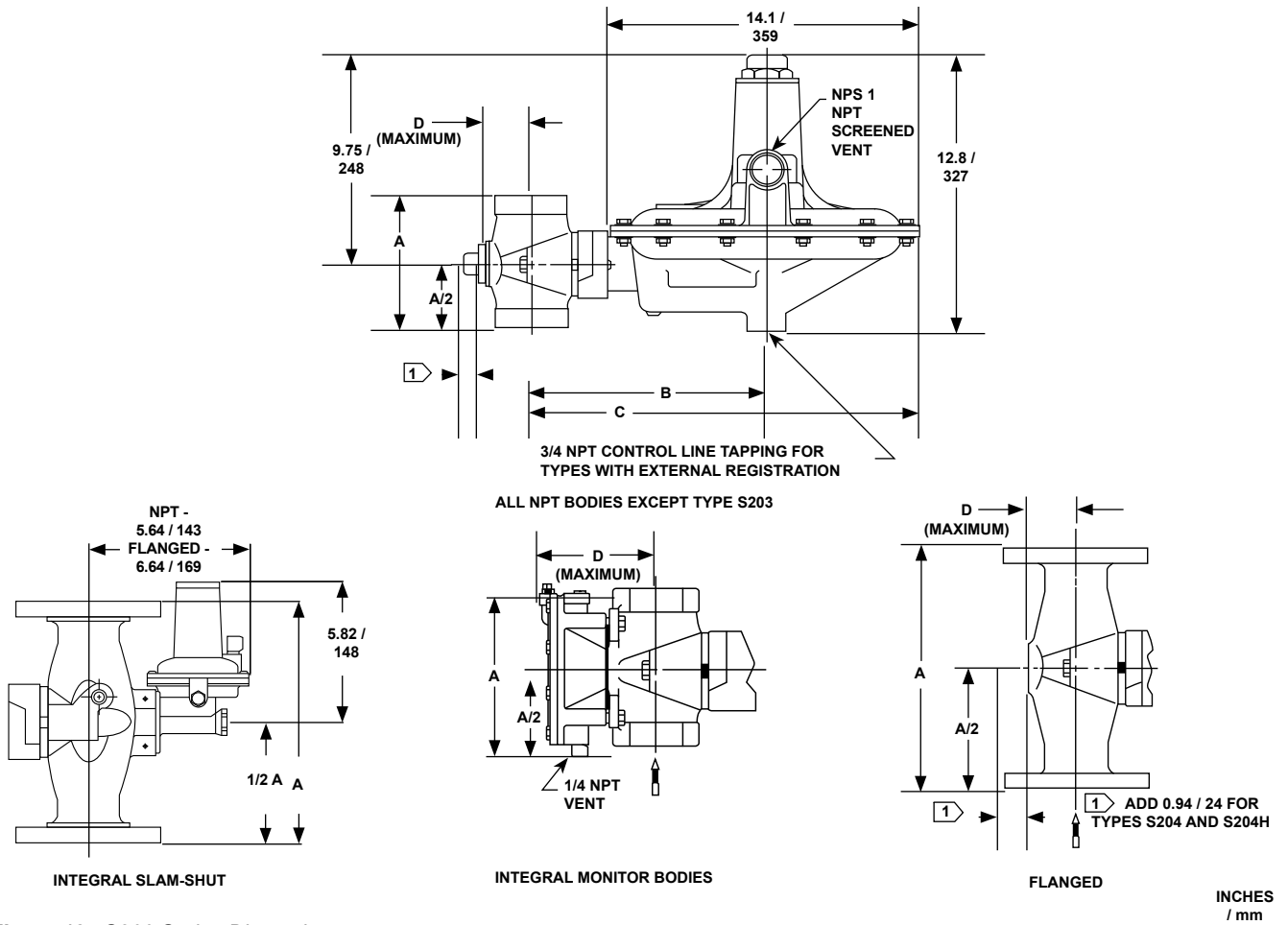

Figure 12. S200 Series Dimensions

Table 12. S200 Series Dimensions

BODY SIZE, NPS / DN	DIMENSIONS (INCHES / mm)									SHIPPING WEIGHT, POUNDS / kg
	A				B	C	True-Monitor™	D		
	NPT	CL125 FF or CL150 RF Flanged	CL250 FF Flanged	PN 10/16 Flanged				NPT	Flanged	
1-1/4 / 32 1-1/2 / 40	6.12 / 155 6.12 / 155	----	----	----	11.06 / 281 11.06 / 281	18.12 / 460 18.12 / 460	4.19 / 106 4.19 / 106	1.44 / 37 1.44 / 37	----	28 / 12.7
1-1/2 x 2 / 40 x 50 2 / 50	6.12 / 155 6.12 / 155	----	10.00 / 254	10.50 / 267	10.19 / 259	10.62 / 270	17.6 / 447	4.19 / 106 4.62 / 117	1.44 / 37 1.88 / 48	

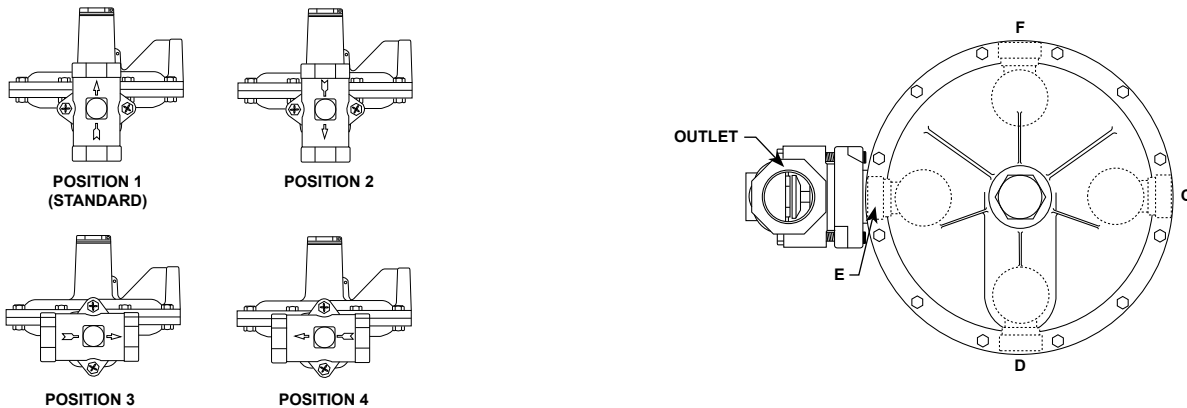

Figure 13. Body Positions and Spring Case Vent Locations

Ordering Information

Refer to the Specifications section on page 4 and to each referenced table. Then, complete the Ordering Guide on pages 30 and 31.

Ordering Guide

Type, See Table 1 (Select One)

- Type S201 (without internal relief)
- Type S201H (Type S201 for outlet pressures up to 5 psig / 0.34 bar)
- Type S201K (Type S201 for outlet pressures up to 10 psig / 0.69 bar)
- Type S201KP (Type S201K with external pressure registration)
- Type S201P (Type S201 with external pressure registration)
- Type S202 (Type S201 with internal relief)
- Type S202H (Type S202 for outlet pressures up to 5 psig / 0.34 bar)
- Type S202P (Type S202 with internal relief)
- Type S203 (Type S201 with integral monitor)
- Type S203H (Type S203 for outlet pressures up to 5 psig / 0.34 bar)
- Type S203P (Type S203 with external registration)
- Type S204 (Type S201 with low outlet pressure shutoff)
- Type S204H (Type S204 for outlet pressures up to 3.25 psig / 0.22 bar)
- Type S206 (Type S204 with internal relief)
- Type S206H (Type S206 for outlet pressures up to 3.25 psig / 0.22 bar)
- Type S208 (Type S201 with slam-shut device)
- Type S208H (Type S208 for outlet pressures up to 5 psig / 0.34 bar)
- Type S208K (Type S208 for outlet pressures up to 10 psig / 0.69 bar)
- Type S208P (Type S208 or S208H with external pressure registration)
- Type S208PK (Type S208K with external pressure registration)
- Type S209 (Type S208 with internal relief)
- Type S209H (Type S209 for outlet pressures up to 5 psig / 0.34 bar)
- Type S209P (Type S209 or S209H with external pressure registration)

Body Size, Material, and End Connection - See Table 1 (Select One)

NPS 1-1/4 Cast Iron (not available for Type S208 or S209)

- NPT***
- BSP*

NPS 1-1/2 Cast Iron (not available for Type S208 or S209)

- NPT***
- BSP*

NPS 1-1/2 Ductile Iron (not available for Type S203, S204, or S206)

- NPT***
- BSP*

NPS 1-1/2 Steel (not available for Type S204, S206, S208, or S209)

- NPT***
- BSP*

NPS 1-1/2 x 2 Ductile Iron (not available for Type S203, S204, or S206)

- NPT***
- BSP*

NPT 2 / DN 50 Cast Iron (not available for Type S208 or S209)

- NPT***
- BSP*
- CL125 FF-7.5-inches / 191 mm***
- CL125 FF-10-inches / 254 mm***

NPS 2 / DN 50 Ductile Iron (not available for Type S203, S204, or S206)

- NPT***
- BSP*
- CL125 FF***
- CL250 RF***
- PN 10-16***

NPS 2 / DN 50 Steel (not available for Type S204, S206, S208, or S209)

- NPT***
- BSP*
- CL150 RF***
- PN 10-16***

- continued -

Ordering Guide (continued)

Outlet Pressure Range (Select One)

Type S201, S201P, S202, or S202P

- 2 to 4.5 inches w.c. / 5 to 11 mbar, Brown***
- 3.5 to 6.5 inches w.c. / 9 to 16 mbar, Red***
- 5 to 9 inches w.c. / 12 to 22 mbar, Black***
- 8.5 to 18 inches w.c. / 21 to 45 mbar, Gray***
- 14 to 30 inches w.c. / 35 to 75 mbar, Dark Green***

Type S201H, S201P, S202H, or S202P

- 1 to 2 psig / 0.07 to 0.14 bar, Dark Blue***
- 1.5 to 3.25 psig / 0.10 to 0.22 bar, Orange***
- 2 to 5 psig / 0.14 to 0.34 bar, Yellow***

Type S201K or S201PK

- 2 to 5.5 psig / 0.14 to 0.38 bar, Green Stripe***
- 4 to 10 psig / 0.28 to 0.69 bar, Unpainted***

Type S203 or S203P

- 2 to 4.5 inches w.c. / 5 to 11 mbar, Brown***
- 3.5 to 6.5 inches w.c. / 9 to 16 mbar, Red***
- 5 to 9 inches w.c. / 12 to 22 mbar, Black***
- 8.5 to 18 inches w.c. / 21 to 45 mbar, Gray***
- 14 to 30 inches w.c. / 35 to 75 mbar, Dark Green***

Type S203H or S203P

- 1 to 2 psig / 0.07 to 0.14 bar, Dark Blue***
- 1.5 to 3.25 psig / 0.10 to 0.22 bar, Orange***

Types S204 and S206

- 3.5 to 5 inches w.c. / 9 to 12 mbar, Brown***
- 5 to 7 inches w.c. / 12 to 17 mbar, Red***
- 6.5 to 9.5 inches w.c. / 16 to 23 mbar, Black***
- 8.5 to 18 inches w.c. / 21 to 45 mbar, Gray***
- 14 to 30 inches w.c. / 35 to 75 mbar, Dark Green***

Types S204H and S206H

- 1 to 2 psig / 0.07 to 0.14 bar, Dark Blue***
- 1.5 to 3.25 psig / 0.10 to 0.22 bar, Orange***

Type S208, S208P, S209, or S209P

- 3.5 to 6.5 inches w.c. / 9 to 16 mbar, Red***
- 5 to 9 inches w.c. / 12 to 22 mbar, Black***
- 8.5 to 18 inches w.c. / 21 to 45 mbar, Gray***
- 14 to 30 inches w.c. / 35 to 75 mbar, Dark Green***

Type S208H, S208P, S209H, or S209P

- 1 to 2 psig / 0.07 to 0.14 bar, Dark Blue***
- 1.5 to 3.25 psig / 0.10 to 0.22 bar, Orange***
- 2 to 5 psig / 0.14 to 0.34 bar, Yellow***

Type S208K or S208PK

- 2 to 5.5 psig / 0.14 to 0.38 bar, Green Stripe***
- 4 to 10 psig / 0.28 to 0.69 bar, Silver***

Orifice Size (Select One)

- 1/4 inch / 6.4 mm^{(1)***}
- 3/8 inch / 9.5 mm***
- 1/2 inch / 13 mm***
- 3/4 inch / 19 mm***
- 1 inch / 25 mm***
- 1 3/16 inch / 30 mm***

Body Position (Select One)

- Position 1 (**standard**)***
- Position 2**
- Position 3**
- Position 4**

Vent Position (Select One)

- Position C**
- Position D (**standard**)***
- Position E**
- Position F**

Type VSX-2 Trip Spring Range (Select One)

- Overpressure (OPSO) Trip Only
(supply high trip pressure)
Indicate trip point
- Over and Underpressure (UPS0) Trip
(supply high and low trip pressure)
Indicate trip points
over _____ under _____

Type VSX-2 Pressure Registration (Select One)

- Internal***
- External***

1. 1/4-inch / 6.4 mm orifice not available for Types S204 and S206.

Regulators Quick Order Guide	
***	Readily Available for Shipment
**	Allow Additional Time for Shipment
*	Special Order, Constructed from Non-Stocked Parts. Consult Your local Sales Office for Availability.
Availability of the product being ordered is determined by the component with the longest shipping time for the requested construction.	

Specification Worksheet

Application:
 Specific Use _____
 Line Size _____
 Gas Type and Specific Gravity _____
 Gas Temperature _____
 Does the Application Require Overpressure Protection?
 Yes No If yes, which is preferred:
 Relief Valve Monitor Regulator Shutoff Device
 Is overpressure protection equipment selection assistance desired? _____

Pressure:
 Maximum Inlet Pressure (P_{1max}) _____
 Minimum Inlet Pressure (P_{1min}) _____
 Downstream Pressure Setting(s) (P_2) _____
 Maximum Flow (Q_{max}) _____

Performance Required:
 Accuracy Requirements? _____
 Need for Extremely Fast Response? _____

Other Requirements: _____

Industrial Regulators

Emerson Process Management Regulator Technologies, Inc.

USA - Headquarters
 McKinney, Texas 75069-1872, USA
 Tel: +1 800 558 5853
 Outside U.S. +1 972 548 3574

Asia-Pacific
 Shanghai 201206, China
 Tel: +86 21 2892 9000

Europe
 Bologna 40013, Italy
 Tel: +39 051 419 0611

Middle East and Africa
 Dubai, United Arab Emirates
 Tel: +971 4811 8100

Natural Gas Technologies

Emerson Process Management Regulator Technologies, Inc.

USA - Headquarters
 McKinney, Texas 75069-1872, USA
 Tel: +1 800 558 5853
 Outside U.S. +1 972 548 3574

Asia-Pacific
 Singapore 128461, Singapore
 Tel: +65 6770 8337

Europe
 Bologna 40013, Italy
 Tel: +39 051 419 0611
 Chartres 28008, France
 Tel: +33 2 37 33 47 00

TESCOM

Emerson Process Management Tescom Corporation

USA - Headquarters
 Elk River, Minnesota 55330-2445, USA
 Tels: +1 763 241 3238
 +1 800 447 1250

Europe
 Selmsdorf 23923, Germany
 Tel: +49 38823 31 287

Asia-Pacific
 Shanghai 201206, China
 Tel: +86 21 2892 9499

For further information visit www.emersonprocess.com/regulators

The Emerson logo is a trademark and service mark of Emerson Electric Co. All other marks are the property of their prospective owners. Fisher is a mark owned by Fisher Controls International LLC, a business of Emerson Process Management.

The contents of this publication are presented for informational purposes only, and while every effort has been made to ensure their accuracy, they are not to be construed as warranties or guarantees, express or implied, regarding the products or services described herein or their use or applicability. We reserve the right to modify or improve the designs or specifications of such products at any time without notice.

Emerson Process Management Regulator Technologies Inc. does not assume responsibility for the selection, use or maintenance of any product. Responsibility for proper selection, use and maintenance of any Emerson Process Management Regulator Technologies Inc. product remains solely with the purchaser.