

May 2018

VSX4 and VSX8 Series Controller

Table of Contents

Introduction	1
Specifications	2
Principle of Operation	4
Installation	6
Dimensions	7
Reed Switch	8
Startup and Shutdown	8
Commissioning	8
Controller Spring Adjustment	8
Maintenance	12
Parts Ordering	13
Parts List	14



WARNING

Failure to follow these instructions or to properly install and maintain this equipment could result in an explosion and/or fire causing property damage and personal injury or death.

Fisher™ controller must be installed, operated and maintained in accordance with federal, state and local codes, rules and regulations and Emerson Process Management Regulator Technologies, Inc. (Emerson) instructions.

Only a qualified person must install or service the VSX4 and VSX8 Series controller. If a leak develops or if the controller continually vents gas, service to the unit may be required. Failure to correct trouble could result in a hazardous condition.

Installation, operation and maintenance procedures performed by unqualified personnel may result in improper adjustment and unsafe operations which may result in equipment damage or personal injury.

The VSX4 and VSX8 Series controller do not activate in response to fire, seismic and lightning events.

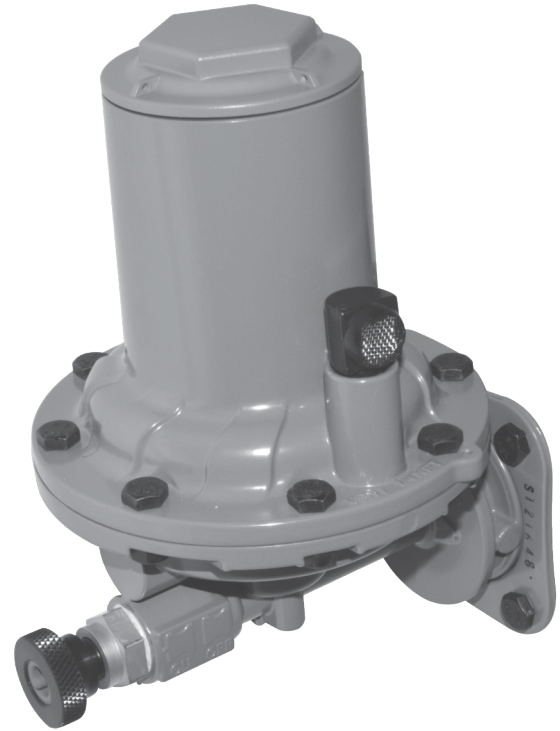

Figure 1. VSX4 and VSX8 Series Controller

Introduction

Scope of the Manual

This Instruction Manual provides installation, adjustment, maintenance and parts ordering information for the VSX4 and VSX8 Series controller. Instructions for other equipment used with the controller, such as pressure regulators, can be found in separate instruction manuals.

VSX4 and VSX8 Series

Specifications

This section lists the specifications for the VSX4 and VSX8 Series controller. The following information is stamped on the nameplate of VSX4 and VSX8 Series: Type and Class, Maximum Outlet Pressure and Spring Range. Additional operating information is located on the Regulator nameplate.

Available Configurations

Types VSX4L and VSX8L: Low-pressure controller which can be integrated into a regulator; with 10 to 1100 mbar / 0.15 to 16 psig downstream pressure

Types VSX4H and VSX8H: High-pressure controller which can be integrated into a regulator; with 1100 to 4000 mbar / 16 to 58 psig downstream pressure

Controller Type

DS: Differential Strength

IS: Integral Strength

Functional Class

A: Min, Min and Max Installation

B: Max Installation Only

Connections

Controller Vent: 1/4 NPT

External Sensing Line: 1/4 NPT

Maximum Allowable Pressure (PS)⁽¹⁾

Differential Strength: 20.0 bar / 290 psig

Integral Strength: 6.0 bar / 87 psig

Specific Maximum Allowable Pressure (PS_s)⁽¹⁾

6.0 bar / 87 psig

Maximum Inlet Pressure (P_{umax})⁽¹⁾

Differential Strength (DS): 16.0 bar / 232 psig

Integral Strength (IS): 6.0 bar / 87 psig

Valve Plug Size

VSX4 Series: 24 mm / 0.94 in.

VSX8 Series: 39 mm / 1.54 in.

Operating Temperature (TS)⁽¹⁾

According to PED Standards

-20 to 66°C / -4 to 150°F

Non-PED: -30 to 66°C / -22 to 150°F⁽²⁾

Casing Material

Aluminum

Response Time (t_a)

< 1 second

Resetting Trip Mechanism

Manually after Fault Rectification

Position Indicator

Extended stem visible in center of reset button

Pressure Registration

Internal or External

European EN Reference Standard

EN 14382

Approximate Shipping Weight

1.4 kg / 3.1 lbs

Options

Wire Seal - The VSX4 and VSX8 Series can be ordered with an optional tamper-proof lock wire to preclude unauthorized access to the adjustment springs.

Reed switch - An optional remote notification switch can be installed offering the capability to remotely notify the operator should VSX8 Series shut off occur. Reed switch is available on our regulators CSB604/704 Series only.

Operating temperature: -40 to 70°C / -40 to 158°F

Degree of Protection: IP67

Product Marking: CE Ex II 2G Ex mb T6 6b

Cable length: 3 m / 118 in.

1. The pressure/temperature limits in this Instruction Manual or any applicable standard limitation should not be exceeded.

2. Product has passed Emerson testing for shutoff and trip function at -40°F.

Product Description

The VSX4 and VSX8 Series controller are designed to shut off the flow of gas to the downstream system in the event of outlet pressure rising above or falling below the predefined levels.

- The VSX4 and VSX8 Series can be mounted on various Emerson regulators or be used as standalone Type VS100 units.
- The VSX4 and VSX8 Series can be integrated in a slam-shut device Type VS100 installed upstream of the associated regulator.
- The VSX4 and VSX8 Series controller are equipped with an internal bypass.
- The VSX4 and VSX8 Series offer either internal or external pressure sensing line, depending on the regulator type and/or the specified conditions.

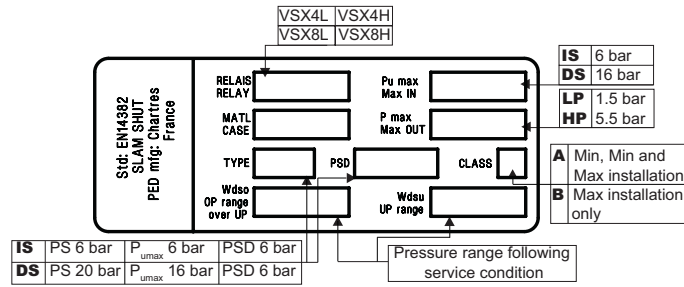

Figure 2. EN 14382-VSX4/VSX8 Series Label

Figure 3. Nameplate for Explosive Atmosphere if ATEX Assembled

Table 1. Directive ATEX Information

TYPE	CLASSIFICATION	ATEX ASSEMBLIES	ATEX LABELLING
VSX4 VSX8	Non-electrical equipment	Not falling under the ATEX Directive 2014/34/EU	No
VSX8 with Reed Contact	Non-electric equipment equipped with an electrical device falling under the scope of the ATEX Directive 2014/34/EU	Constitutes an assembly according to the ATEX Directive 2014/34/EU	

Table 2. Overpressure Shutoff (OPSO) Only Spring Ranges

SLAM SHUT DEVICE						
Type	Inlet Pressure		Over Pressure Shut-off (OPSO) Set Range		OPSO Spring	
	bar	psig	mbar	psig	Part Number	Spring Color
VSX4L VSX8L	8.6 and 16	125 and 232	30 to 60	12 to 24 in. w.c.	GF02168X012	Brown
			40 to 110	16 in. w.c. to 1.6 psig	GF02169X012	Red
			60 to 193	24 in. w.c. to 2.8 psig	GF02170X012	Orange
			95 to 280	1.4 to 4.1	GF02171X012	Pink
			138 to 500	2.0 to 7.3	GF02172X012	Green
			221 to 760	3.2 to 11.0	GF02173X012	Silver
			400 to 1450	5.8 to 21.0	GF04353X012	Yellow
VSX4H VSX8H	16	232	400 to 1100	5.8 to 16.0	GF02171X012	Pink
			580 to 2000	8.4 to 29.0	GF02172X012	Green
			900 to 3000	13.1 to 43.5	GF02173X012	Silver
			1600 to 5500	23.2 to 79.8	GF04353X012	Yellow

VSX4 and VSX8 Series

Table 3. Combined Overpressure and Underpressure Shutoff (OPSO and UPSO) Spring Ranges

SLAM SHUT DEVICE										
Type	Inlet Pressure		Under Pressure Shut-off (UPSO)		UPSO Spring		Over Pressure Shut-off (OPSO)		OPSO Spring	
			Set Range		Part Number	Spring Color	Set Range Over UPSO Setpoint		Part Number	Spring Color
	bar	psig	mbar	psig			mbar	psig		
VSX4L VSX8L	8.6	125	7 to 11		ERAA05835A0	White	30 to 44		GF02167X012	Black
			7 to 15				32 to 44			
			7 to 30	3 to 12 in. w.c.			41 to 44	16 to 18 in. w.c.		
			10 to 75	4 in. w.c. to 1.1 psig	T14169T0012	Blue	40 to 76	16 to 29 in. w.c.	GF02168X012	Brown
			25 to 160	10 in. w.c. to 2.3 psig	T14170T0012	Silver	48 to 74	19 in. w.c. to 1.1 psig	GF02169X012	Red
			100 to 500	1.5 to 7.3	FA142869X12	Orange Stripe	50 to 122	20 in. w.c. to 1.8 psig	GF02170X012	Orange
			100 to 750	1.5 to 10.9	T14171T0012	Olive	114 to 261	1.7 to 3.8	GF02171X012	Pink
	16	232	7 to 30	3 to 12 in. w.c.	ERAA05835A0	White	179 to 386	2.6 to 5.6	GF02172X012	Green
			10 to 75	4 in. w.c. to 1.1 psig	T14169T0012	Blue	241 to 565	3.5 to 8.2	GF02173X012	Silver
			25 to 160	10 in. w.c. to 2.3 psig	T14170T0012	Silver	460 to 932	6.7 to 13.5	GF02167X012	Black
			100 to 500	1.5 to 7.3	FA142869X12	Orange Stripe	40 to 55	16 to 22 in. w.c.	GF02168X012	Brown
			100 to 750	1.5 to 10.9	T14171T0012	Olive	45 to 76	18 to 30 in. w.c.	GF02169X012	Red
							50 to 80	20 in. w.c. to 1.1 psig	GF02170X012	Orange
							62 to 132	25 in. w.c. to 1.9 psig	GF02171X012	Pink
VSX4H VSX8H	16	232	500 to 2000	7.3 to 29.0	FA142869X12	Orange Stripe	179 to 386	2.6 to 5.6	GF02172X012	Green
			500 to 2800	7.3 to 40.6	T14171T0012	Olive	241 to 565	3.5 to 8.2	GF02173X012	Silver

■ - Not available for North America.

Table 4. Controller Accuracy in Accordance to EN 14382

ACCURACY GROUP (AG)	$P_d < 35 \text{ mbar} / 0.507 \text{ psig}$	$35 \text{ mbar} / 0.507 \text{ psig} \leq P_d < 60 \text{ mbar} / 0.87 \text{ psig}$	$60 \text{ mbar} / 0.87 \text{ psig} \leq P_d < 100 \text{ mbar} / 1.5 \text{ psig}$	$P_d \geq 100 \text{ mbar} / 1.5 \text{ psig}$
AG _{min}	30	15	10	5
AG _{max}	10	10		

Note: Stable inlet pressure AG_{min} = AG 10 ($P_d < 60 \text{ mbar} / 0.87 \text{ psig}$) and AG 5 ($P_d > 60 \text{ mbar} / 0.87 \text{ psig}$), AG_{max} = AG 5

Principle of Operation

VSX4 and VSX8 Series Controller

The pressure measuring element of the controller consists of a diaphragm that senses downstream pressure. The downstream pressure is controlled by the regulator. The overpressure shut-off spring and under-pressure shut-off spring exerts force on the top side of the diaphragm.

When the downstream pressure increases above the Overpressure Shutoff (OPSO) setting, the diaphragm moves up.

When the downstream pressure decreases below the Underpressure Shutoff (UPSO) setting, the diaphragm moves down.

Both of these actions result in the rotation of the cam and the release of the reset pin.

The valve plug spring then pushes the valve plug against the regulator port, stopping the flow of gas. The reset button is then used to reset (relatch) the controller (refer to the *Resetting Procedure* section for detailed resetting instructions).

Standard downstream pressure registration for the controller is external; however, internal sensing line is made available by removing the downstream sense blocking screw, installing a 1/4 NPT plug in the control line port and removing the downstream control line.

VSX4 and VSX8 Series

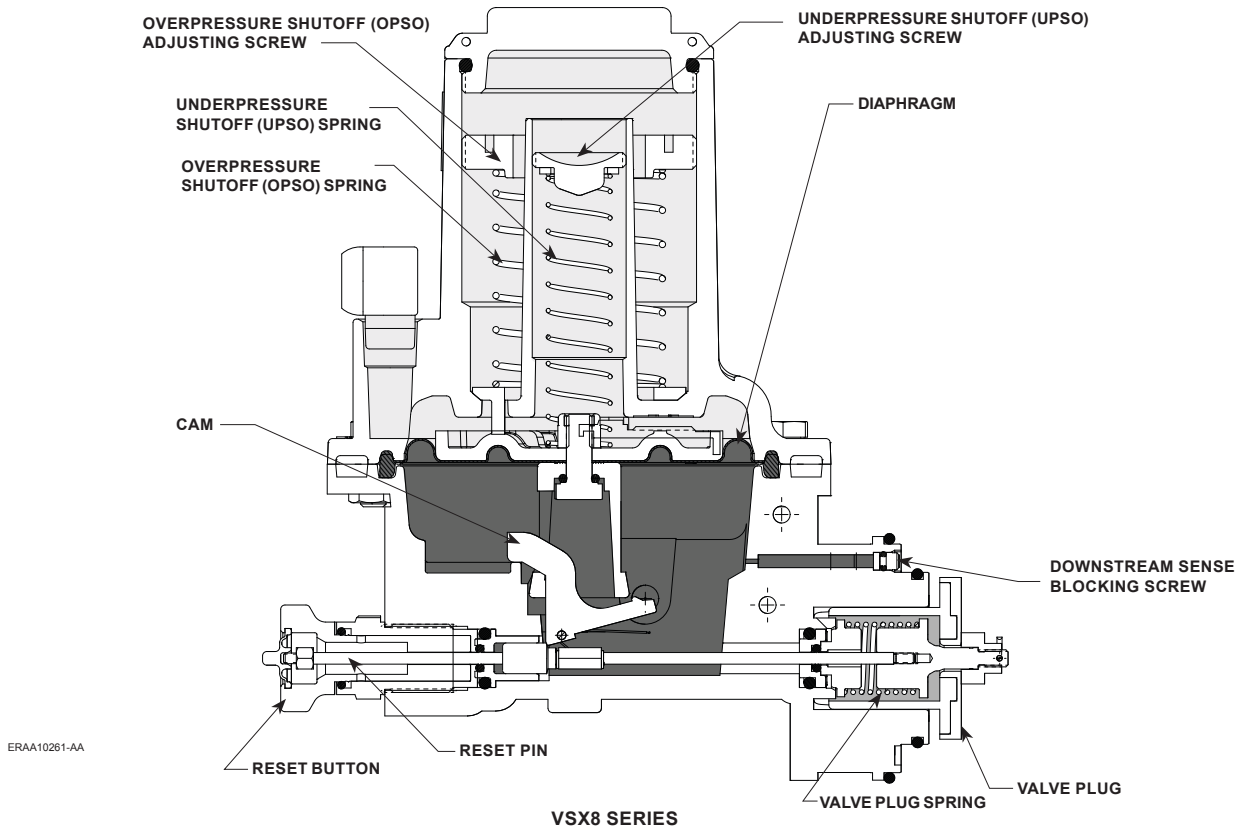

ERAA10261-AA

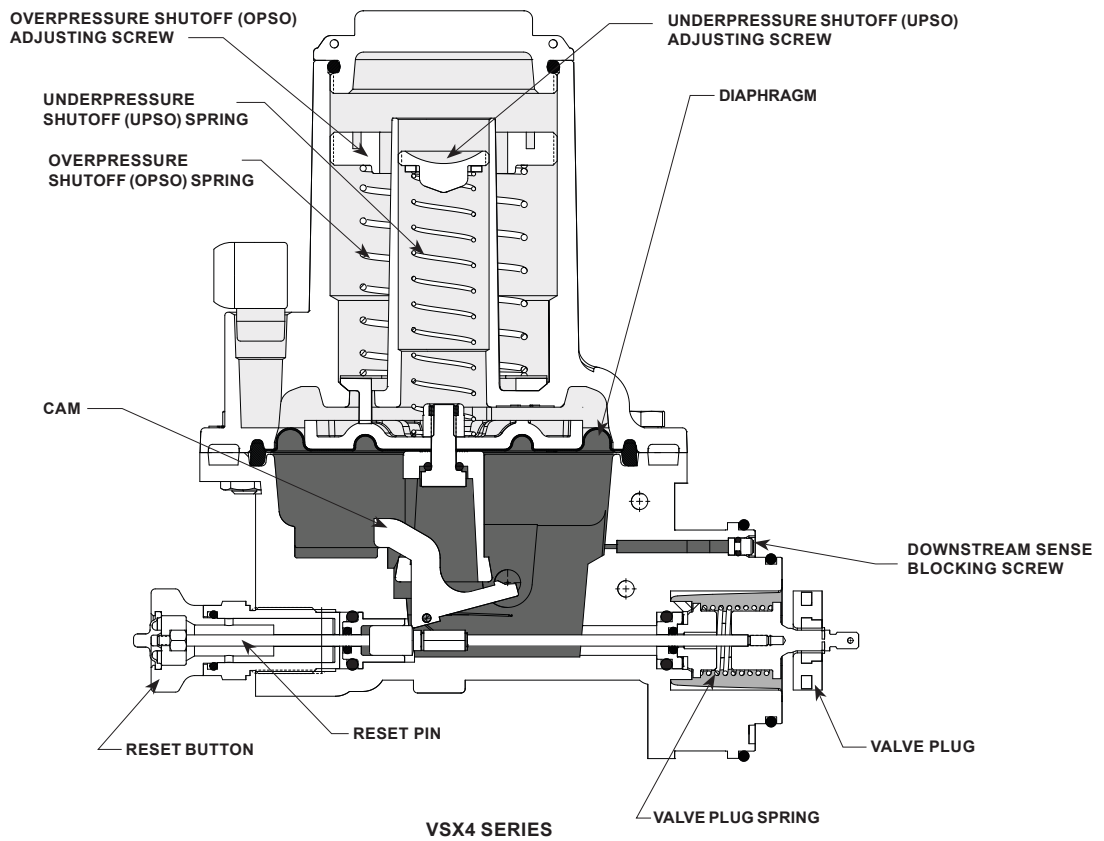

ERAA11922-02

- INLET PRESSURE, P_a
- OUTLET PRESSURE, P_d
- ATMOSPHERIC PRESSURE, P_b

Figure 4. VSX4/VSX8 Series Operational Schematics

VSX4 and VSX8 Series

Table 5. Controller Standard Factory Settings

REGULATOR SETPOINT, mbar / psig	CONTROLLER STANDARD SETTINGS		
	UPSO / Minimum	OPSO ⁽¹⁾⁽²⁾ / Maximum	OPSO ⁽³⁾ / Maximum
$P_d < 35 / 0.51$	$P_d \times 0.5$	$P_d \times 2.0$	$P_d \times 2.0 + 10 \text{ mbar} / 0.145 \text{ psig}$
$35 / 0.51 \leq P_d < 60 / 0.87$	$P_d \times 0.5$	$P_d \times 1.7$	$P_d \times 1.7 + 10 \text{ mbar} / 0.145 \text{ psig}$
$60 / 0.87 \leq P_d < 160 / 2.32$	$P_d \times 0.6$	$P_d \times 1.5$	$P_d \times 1.5 + 10 \text{ mbar} / 0.145 \text{ psig}$
$160 / 2.32 \leq P_d < 180 / 2.61$	$P_d \times 0.7$	$P_d \times 1.4$	$P_d \times 1.4 + 10 \text{ mbar} / 0.145 \text{ psig}$
$180 / 2.61 \leq P_d < 300 / 4.35$	$P_d \times 0.7$	$P_d \times 1.4$	----
$300 / 4.35 \leq P_d$	$P_d \times 0.7$	$P_d \times 1.3$	
The VSX4 Series assembly part number (without valve plug and controller springs): LP: GE35589X012, HP: GE35590X012 The VSX8 Series assembly part number (without valve plug and controller springs): LP: ERCA02667A0, HP: ERCA02668A0			
1. Regulator without relief valve (or with relief valve set above controller setting). 2. When selecting OPSO set points, the outlet pressure rating of the regulator should be considered. 3. Regulator with relief valve (set below controller setting).			

Installation



Personal injury or system damage may result if this controller is installed, without appropriate overpressure protection, where service conditions could exceed the limits given by the nameplates of either the regulator or controller or exceed the limits indicated in the regulator or controller instruction manuals.

All vents should be kept open to permit free flow of gas to the atmosphere. Protect openings against entrance of rain, snow, insects or any other foreign material that may plug the vent or vent line. When installing outdoors, point the spring case vent of the regulator and of the controller downward to allow condensate to drain. This minimizes the possibility of freezing and accumulation of water or other foreign materials entering the vent and interfering with proper operation.

Controller installations should be adequately protected from physical damage.

The equipment should not receive any type of shock causing damage to the casing and therefore causing leaks.

No modification should be made to the structure of the equipment (drilling, grinding and soldering).

Under enclosed conditions or indoors, escaping gas may accumulate and be an explosion hazard. In these cases, the vent(s) should be piped away from the regulator/controller to the outdoors.

Failure to install a downstream control line could result in a hazardous condition. Install downstream control line(s) to the controller when construction uses external pressure registration. The regulator and controller

will not control pressure or shut off if a downstream control line is not installed on those constructions where external pressure sensing line is required.

If the controller is exposed to an overpressure condition, it should be inspected for any damage that may have occurred. Controller operation within ratings does not preclude the possibility of damage from external sources or from debris in the pipeline.

General Installation Instructions

Note

The VSX4 and VSX8 Series can be rotated 360° for easy installation and maintenance.

Install, use and maintain in accordance to all applicable codes and standards.

Before proceeding to installation:

- Ensure that the controller is compatible with the gas being regulated.
- Check for damage that might have occurred during shipment.
- Check for and remove any dirt or foreign material that may have accumulated in the regulator or controller body.
- Ensure that the external or internal sense port is clean.
- When applying pipe sealing compound to piping and fittings, always apply to external threads.
- Verify that:
 - Equipment limits of utilization (PS, TS) correspond to the desired operating conditions.
 - The inlet is protected by an appropriate device(s) to avoid exceeding the allowable limits (PS, TS).
 - The controller and its springs correspond to the desired operating conditions of associated regulator.
- Connect downstream control line tubing to the 1/4 NPT connection in the lower casing and to the downstream pipe respecting a minimum distance of four times its diameter (see Figure 6).
- Periodically check all vent openings to be sure that they are not plugged.

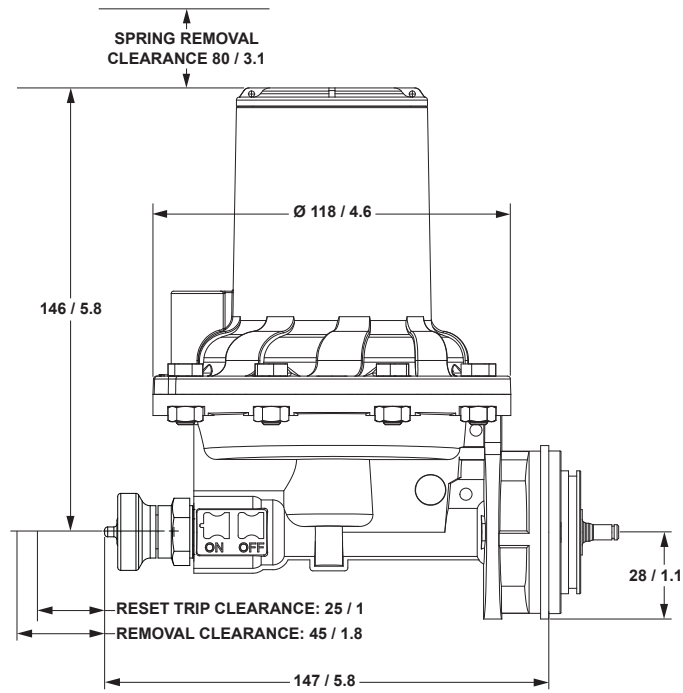

mm / IN.

Figure 5. Controller External Dimensions

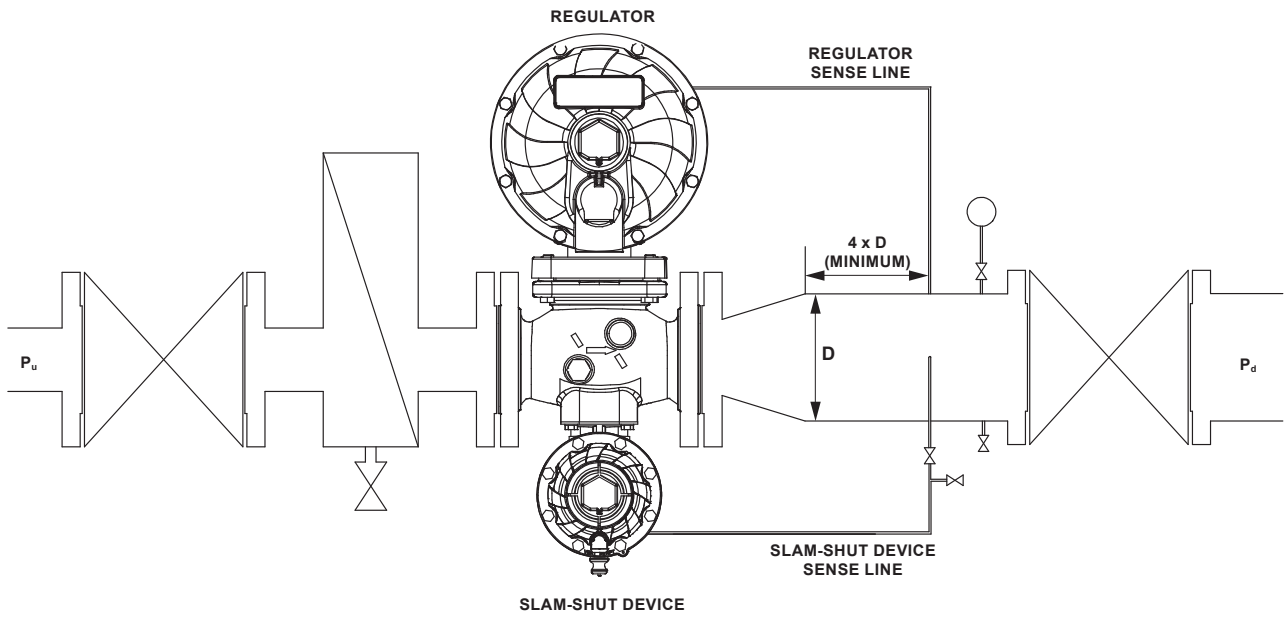

Figure 6. Typical Installation

VSX4 and VSX8 Series

Reed Switch



WARNING

Do not use the manual button if there is no plug. This action may damage the magnet associated with the reed contact if trip the VSX8 Series.

An optional remote notification switch can be installed offering the capability to remotely notify the operator should VSX8 Series shut off occur. Reed switch is available on our regulators CSB604/704 Series only.



WARNING

Do not pull, pinch or carry the VSX8 Series by the cable of contact reed. Unsuitable handling of cable can damage the reed contact.

Description and Recommendations

This electrical contact is a limit switch contact based on the reed contact principle. The actuation takes place through a permanent magnet. The operation of the electrical contact may be affected by magnetic materials. Initial commissioning is done in combination with a signal processing control device. The operator must check the electrical data for the VSX8 Series tripping. The reed contacts must be installed in such a way as to be protected against mechanical hazards as well as prolonged exposure to sunlight. Specific instructions are available in the supplier's instruction manual.

Installation

The contact reed option is available on VSX8 Series mounted in our factory for a CSB604 and CSB704 Series only. It cannot be supplied alone for later installation on VSX8 Series on the field.



WARNING

The usage of an assembly incorporating an electrical accessory in an explosive atmosphere the release relay VSX8 Series equipped with an electrical accessory (proxy, microswitch) is:

- is classified "assembly" in conformity with the ATEX Directive 2014/34/EU (ref CEN/SFG-I Guidance sheet -February 2015)
- can be installed in any type of classified zones according to the Directive 1999/92/EC dated 16 December 1999, according to the following conditions:
 - a) the equipment(s) is connected to a suitable and certified intrinsically safe apparatus/electric circuit (zener barrier)

Additional electrical data for intrinsic safety protection use: the encapsulated protection mode as a single electric device is compatible with use "ia" within following conditions:

P_i max: 3W/VA
 U_i max: 30V AC/DC
 I_i max: 200 mA
 $C = 0.1$ nF/m
 $L = 500$ μ H/m

- b) the equipment is used according to the appropriate instruction manual issued by the manufacturer and/or available on our website
- c) when the equipment is used in a natural gas pressure reducing and/or metering station in compliance with the following European standards: EN 12186, EN 12279 and EN 1776.

Startup and Shutdown



CAUTION

This Instruction Manual should be used in conjunction with the instruction manual of the associated equipment.

Commissioning



WARNING

All interventions on the equipment should only be performed by competent and trained personnel.

Controller Spring Adjustment



WARNING

Before proceeding with the adjustment of the controller springs, the operator must ensure upstream and downstream valves are closed and adjusting screws (keys 43 and 40, Figure 15) are unscrewed (refer to Table 6).

Overpressure and Underpressure Shutoff (OPSO/UPSO) Setpoint Adjustment (Figures 4 and 15)

- Using a flathead screwdriver or 1/4 in. drive socket, turn the OPSO adjusting screw (key 43) clockwise until it stops turning.
- Apply nominal outlet pressure of the associated regulator to the downstream system. Refer to Figure 6.
- Reset the controller per the resetting procedure (refer to the *Resetting Procedure* section for detailed resetting instructions).
- Slowly decrease the downstream pressure to the desired UPSO value (P_{dsu}).
- With a screwdriver or 1/4 in. drive socket, turn the UPSO adjusting screw clockwise (key 40) until the controller trips.
- Apply nominal outlet pressure of the associated regulator to the downstream system.
- Reset the controller by pulling the reset button (key 30) until the mechanism is latched.
- Slowly increase the downstream pressure to the desired OPSO shutoff value (P_{dso}).
- With a screwdriver or 1/4 in. drive socket, turn the OPSO adjusting screw counterclockwise (key 43) until the controller trips.

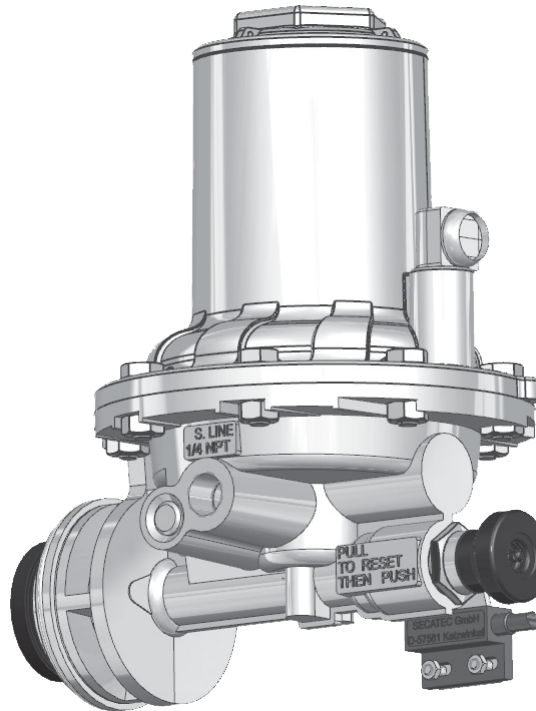
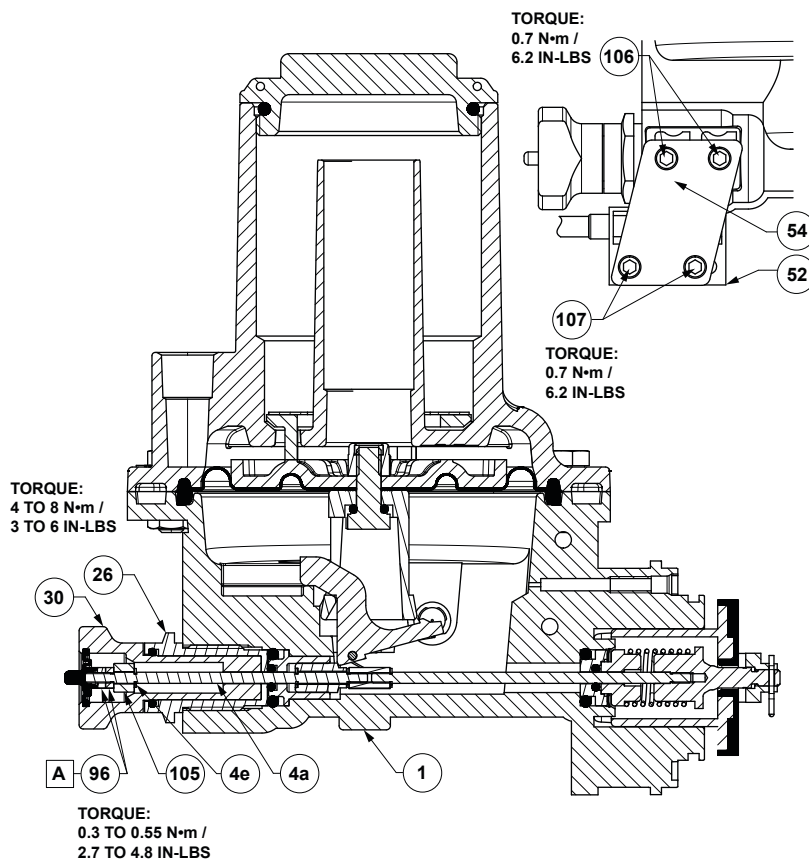

Figure 7. VSX8 Series with Reed Switch



APPLY ADHESIVE⁽¹⁾:

1. Adhesives must be selected such that they meet the temperature requirements.

Figure 8. Installation of Reed Switch

VSX4 and VSX8 Series

Manual Shut-Off Button Procedure For VSX4 And VSX8 Series

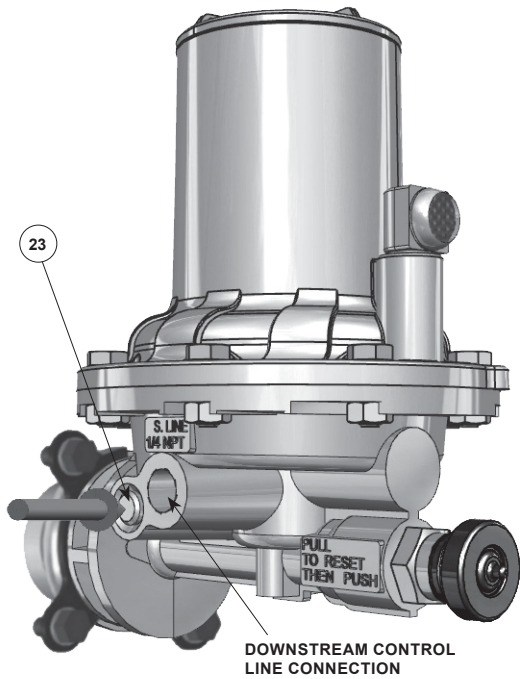

Figure 9. Controller Manual Shut-off Button (key 23)

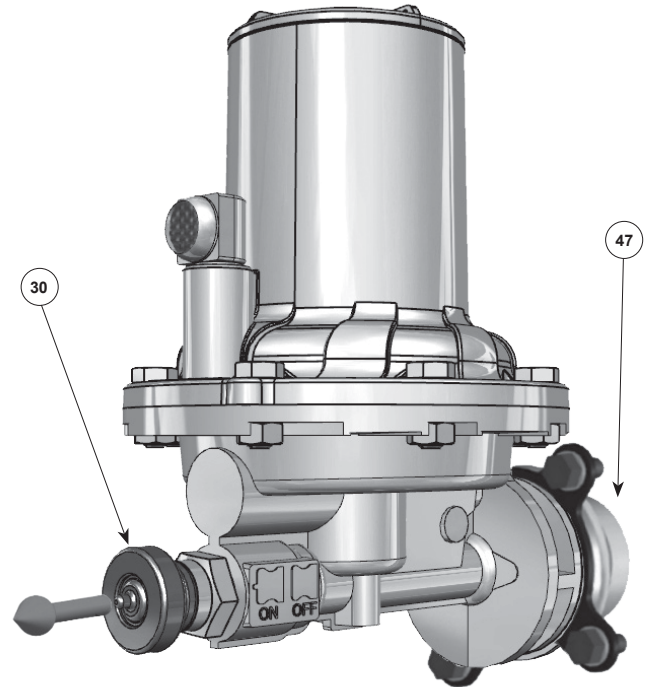

Figure 10. Controller Manual Bypass

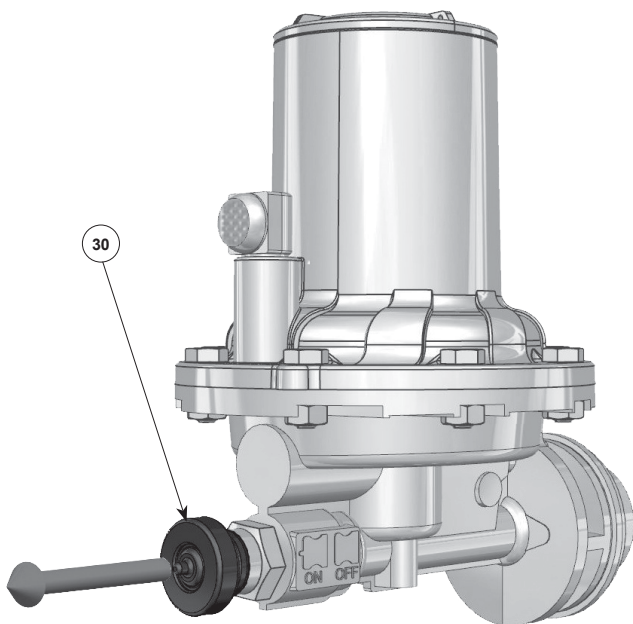

Figure 11. Relating the Controller Mechanism

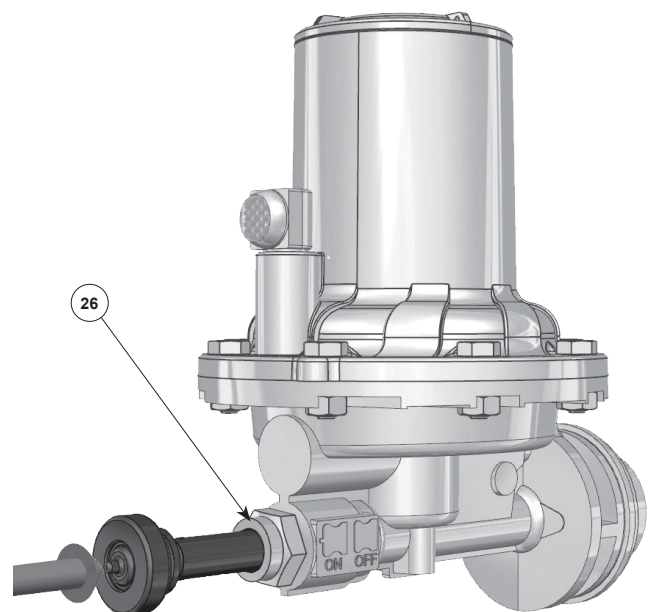

Figure 12. Repositioning the Reset Button

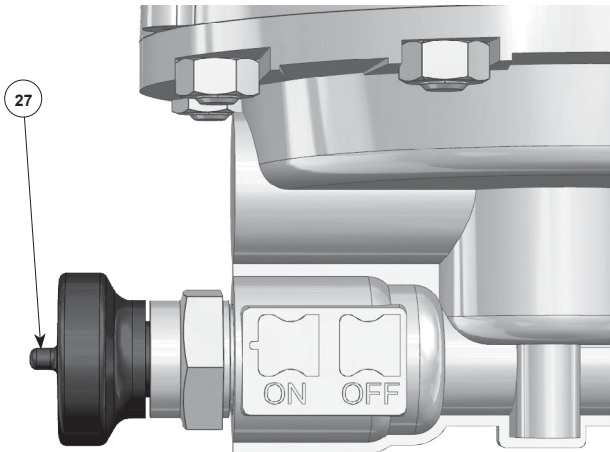

Figure 13. Controller in Open (Reset) Position

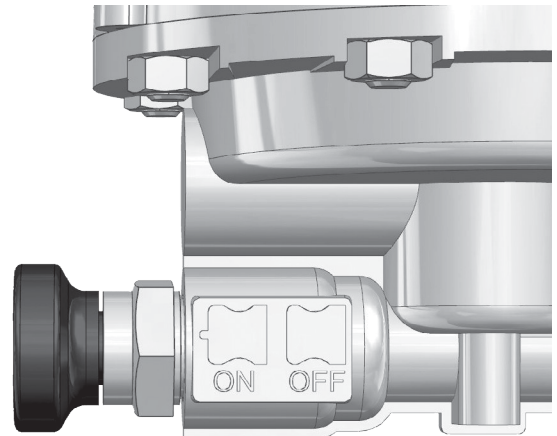

Figure 14. Controller in Closed (Tripped) Position

Systematic Maintenance is Recommended as Specified Below:

Table 6. Flow Chart for Checking Shut-off Mechanism

- CLOSE THE UPSTREAM VALVE - CLOSE THE DOWNSTREAM VALVE	
High-Pressure Shutoff	Low-Pressure Shutoff
Supply pressure through outlet purge valve.	Open the purge valve.
Check the value of the shut-off pressure and for any downstream leakage.	Check the value of the shut-off pressure and for any downstream leakage.
Adjust the setpoint, if necessary.	Adjust the setpoint, if necessary.

Overpressure Shutoff (OPSO) Setpoint Adjustment Only (Figures 4 and 15)

- Using a flathead screwdriver or 1/4 in. drive socket, turn the OPSO adjusting screw (key 43) clockwise until it stops turning.
- Apply nominal outlet pressure of the associated regulator to the downstream system.
- Reset the controller per the resetting procedure, (Refer to the Resetting Procedure section for detailed resetting instructions).
- Slowly increase the downstream pressure to the desired OPSO value (P_{dso}).
- Using a flathead screwdriver or 1/4 in. drive socket, turn the OPSO adjusting screw counterclockwise (key 43) until the controller trips.

Manual Shut-off Procedure (Figure 9)

Using a screwdriver, press the manual shut-off button (key 23) to manually trip the controller.

Manual Reset Procedure (Figures 10 to 13) for VSX4 and VSX8 Series

CAUTION

Equipment installed downstream of the controller can be damaged if the following procedure for resetting the controller is not followed. This equipment includes the integral controller/regulator configurations.

Note

An OPSO spring must be present and adjusted before proper reset can be achieved. If OPSO adjustment has not yet been made, a FULL adjustment can be used.

Note

Test lockup of the regulator and replace the regulator valve plug/disks as needed.

Step 1:

- Slowly pull the reset button (key 30) away from the controller. This slow movement allows for a slow bleed of the pressure across the controller's disk and seat area. The operator should be able to hear the pressure bleeding through the system.

Step 2:

- When the pressure has equalized and the air bleeding sound has dissipated, the reset button (key 30) can be pulled completely away from the controller by hand until the internal shut-off mechanism has been re-latched.

Step 3:

- Once the operator feels the click of the re-latch occurring, the reset button (key 30) should be pushed completely back into its original position.

Trip Indicator (Figures 13 and 14)

The trip indicator (key 27) provides a visual indication as to whether the controller is opened (latched/reset) or closed (tripped).

VSX4 and VSX8 Series

Controller in Open (Reset) Position (Figure 13)

When the controller is in the open position, the trip indicator (key 27) is visible and firm when pressed with a finger.

Controller in Closed (Tripped) Position (Figure 14)

When the controller is in the closed position, the trip indicator (key 27) is not visible and easily moved when pressed inward with a finger.

Maintenance

WARNING

Only a competent and qualified person may perform maintenance procedures. If necessary, contact your local Sales Office for assistance.

Failure to test the controller for proper shutoff can result in a hazardous condition. Test the controller for operation per applicable federal, state and local codes, rules and regulations and Emerson instructions.

Due to normal wear or damage that may occur from external sources, the controller should be inspected and maintained periodically. The frequency of inspection and replacement depends on the severity of service conditions and on applicable codes and regulations. In accordance with applicable National or Industry codes, standards and regulations/recommendations, all hazards covered by specific tests after final assembly before applying the CE marking, shall also be covered after every subsequent reassembly at installation site, in order to ensure that the equipment will be safe throughout its intended life.

Periodic inspection must be performed on the VSX4 and VSX8 Series. The controller should be tested for both under and overpressure shutoff activation and pressure tight shutoff annually with test intervals not to exceed 15 months but at least once each calendar year. If the controller does not close at the desired pressures or leaks gas after closure, repair and/or replace the controller. For the verification of internal parts and replacement of worn parts, the controller should be disassembled every 3 years minimum.

Disassembly and Reassembly

Note

User should only disassemble the controller to replace the Valve Plug (Disk), change registration from Internal to External and Spring and Diaphragm Replacement as described below.

All other internal disassembly requires special tooling and should be done only at the factory; for example the cam and reset pin assembly (key 4, Figure 15).

WARNING

Only parts manufactured by Emerson should be used for repairing the VSX4 and VSX8 Series Slam-shut Device.

Valve Plug (Disk) Replacement

WARNING

To avoid personal injury or equipment damage, do not attempt any maintenance or disassembly without first isolating the regulator/controller from system pressure and relieving all internal pressure.

Installation of an incorrect size valve plug (disk) will prevent the controller from shutting off the flow of gas in an overpressure or under pressure scenario resulting in a hazardous condition. A 39 mm / 1.54 in. diameter valve plug must be installed in VSX8 Series controllers for proper operation. VSX4 Series controllers require the use of the 24 mm / 0.94 in. diameter valve plug.

- Refer to Figure 15 when following this procedure. Remove the body flange screws (key 34) and the two half flanges (key 36). Remove the controller from the body.
- For VSX4 Series disk replacement, remove the fastening ring (key 44). For VSX8 Series disk replacement, remove the travel stop/cotter pin (key 53) and the safety nut (key 58). For specific tools needed for this step, see Table 7.
- Remove and replace the valve plug (disk) (key 47).
- Replace the fastening ring (key 44) or safety nut (key 58) and cotter pin (key 53). To replace the safety nut (key 58) screw the nut onto the plug support until it stops and then reverse the nut until the cotter pin (key 53) can be assembled.
- Reassemble in reverse order, taking care to follow the steps outlined in the General Controller Reassembly Procedures section.
- Test the controller for proper operation at the desired OPSO and/or UPSO set points. Readjust set point(s) if needed.

Changing from Internal to External Registration

WARNING

To avoid personal injury or equipment damage, do not attempt any maintenance or disassembly without first isolating the regulator/controller from system pressure and relieving all internal pressure.

Table 7. Recommended Tools

TOOL	USAGE
Flathead screwdriver and 1/4 in. drive	• Adjustment of Overpressure and Underpressure Shutoff (OPSO / UPSO) setting
10 mm / 3/8 in. Wrench	• Removal and installation of the actuator screws (key 16, Figure 15) • Removal and installation of body flange screws (key 34, Figure 15) • Removal and installation of the lock nut (key 31, Figure 15)
14 mm / 9/16 in. Wrench	• Removal and installation of the external sense line 1/4 NPT connection (Figure 6)
Internal retaining ring pliers	• Removal and installation of the VSX4 Series fastening ring (key 44, Figure 15)
Needle Nose Pliers	• Removal and installation of Cotter Pin for VSX8 Series

Table 8. VSX4 and VSX8 Series Troubleshooting

INDICATION	CAUSE	ACTION
If the valve will not close	Operating fault	Check the following: • The shut-off pressure settings for high and low pressure values are correct. • The O-rings are sealing tightly. • The sensing line is plugged. Remove the controller and check the following: • The reset latch is not stuck. • The state of the diaphragm assembly for wear and tear. Or contact your local Sales Office.
If the downstream pressure in the controller decreases	External leak	Locate and seal the leak. Or contact your local Sales Office.
If the outlet pressure in the controller is constant	----	• Bleed off the outlet side of the regulator. • Observe the evolution of the outlet pressure (check tightness).
If the downstream pressure in the controller increases	Internal leak	Check the following: • The valve plug (disk) • The internal interface O-ring (key 46, Figure 15) • The reset stem O-ring (key 29, Figure 15) Or contact your local Sales Office.

- Refer to Figure 15 when following this procedure. Remove the body flange screws (key 34) and the two half flanges (key 36). Remove the controller from the body.
- Install the sense blocking screw (key 51) and O-ring (key 50).
- Remove the 1/4 NPT plug from the 1/4 NPT Control line port (Figure 6).
- Reassemble in reverse order, ensure to follow the steps outlined in the General Controller Reassembly Procedures section.
- Connect a downstream control line with an outer diameter of 6.4 mm / 0.25 in. or larger to the 1/4 NPT Control line port shown in Figure 6 and to the downstream system as indicated in Figure 6.

Spring and Diaphragm Replacement

- Refer to Figure 15 when following this procedure. Unscrew and remove the closing cap (key 3). Using a flathead screwdriver, unscrew and remove the OPSO adjusting screw (key 43), OPSO spring (key 41), maximum washer (key 42).
- Unscrew and remove the UPSO adjusting screw (key 40), mini washer (key 103) and UPSO spring (key 38).
- Using a 10 mm / 3/8 in. wrench, unscrew and remove the eight spring case screws (key 16) and associated nuts (key 12) and then remove the spring case (key 2). For Type VSX4H or VSX8H, remove the diaphragm support (key 32).
- To remove the diaphragm assembly, gently grasp the edge of the diaphragm (key 6) while at the same time pulling the reset button (key 30) slightly, which will allow for sliding the back plate (key 5) off of the cam (key 19).
Grasp the back plate (key 5) and unscrew the nut (key 31) using a 10 mm / 3/8 in. wrench. Remove the diaphragm plate (key 7) and inspect the diaphragm and replace if necessary. The lock nut (key 31) should always be replaced.
Reassemble in reverse order, ensure to follow steps outlined in the following section "General Controller

Reassembly Procedures." Note that when tightening the lock nut (key 31) onto screw (key 16), a hexagonal recess exists at the bottom of the back plate (key 5) that precludes the screw (key 16) from turning to allow the lock nut (key 31) to be threaded.

General Controller Reassembly Procedures

- It is recommended that O-rings (keys 14 and 24) be replaced before reinstalling the controller valve onto the regulator body.
- Before reassembly, inspect removed O-rings for damage or wear and replace if necessary.
- Before reassembly, apply silicone grease lubricant to the appropriate O-rings.
- Using graphite molybdenum, grease appropriate screws, setting nuts and springs (keys 38, 40, 41, 43 and 103).
- Recommended torque for screws (key 16) is 6.0 N•m / 4.4 ft-lbs.
- Recommended torque for lock nut (key 31) is 3 N•m / 27 in-lbs.
- Recommended torque for the body flange screws (key 34) is 6 N•m / 4.4 ft-lbs.

Parts Ordering

Controller that have been disassembled for repair must be tested for proper operation before being returned to service.

The type number, pressure ranges, functional class and date of manufacture are stamped on the nameplate. Always provide this information when corresponding with your local Sales Office regarding replacement parts or technical assistance.

When ordering replacement parts, refer to the key number of each needed part as found in the parts list.

Separate kits containing all recommended spare parts are available. See tables on pages 14 and 16.

VSX4 and VSX8 Series

Parts List

VSX4 and VSX8 Series Controller

KEY	DESCRIPTION	QUANTITY	LOW PRESSURE	HIGH PRESSURE	LOW PRESSURE	HIGH PRESSURE
			Type VSX4L	Type VSX4H	Type VSX8L	Type VSX8H
1	Lower Case	----	-----	-----	-----	-----
2*	Upper Case	1	GF01866X012	GF01866X012	GF01866X012	GF01866X012
3*	Closing Cap	1	ERAA08178A0	ERAA08178A0	ERAA08178A0	ERAA08178A0
4	Reset pin	----	-----	-----	-----	-----
5	Back plate	----	-----	-----	-----	-----
6*	LP/HP Diaphragm	1	ERAA08900A0	ERAA08900A0	ERAA08900A0	ERAA08900A0
7*	Diaphragm Plate	1	GF01927X012	GF01944X012	GF01927X012	GF01944X012
8	Safety plug spring	----	-----	-----	-----	-----
9*	Plug support	1	ERAA08609A0	ERAA08609A0	ERAA08609A0	ERAA08609A0
10	Spring locator	----	-----	-----	-----	-----
12*	Nut H M6	8	GE38209X012	GE38209X012	GE38209X012	GE38209X012
13	Ring	----	-----	-----	-----	-----
14*	O-ring 51.00x3.00	1	GF03448X012	GF03448X012	GF03448X012	GF03448X012
15	Self-Locking Ring	----	-----	-----	-----	-----
16*	Screw H M6x16	9	GE38207X012	GE38207X012	GE38207X012	GE38207X012
18	Axis	----	-----	-----	-----	-----
19	Cam	----	-----	-----	-----	-----
20	Screw M4x8	----	-----	-----	-----	-----
21	Spring, Torsion	----	-----	-----	-----	-----
22	Fastening clip	----	-----	-----	-----	-----
23	Manual Button	----	-----	-----	-----	-----
24*	O-ring (5.7x1.9)	2	GF03445X012	GF03445X012	GF03445X012	GF03445X012
25	Relatching Spring	----	-----	-----	-----	-----
26	Gland sleeve	----	-----	-----	-----	-----
27	Indicator Diaphragm	----	-----	-----	-----	-----
28	O-ring R8 (8.90x2.70)	----	-----	-----	-----	-----
29	O-ring R1 (2.60x1.90)	----	-----	-----	-----	-----
30	Reset button	----	-----	-----	-----	-----
31*	Safety nut H M6	1	FA404550X12	FA404550X12	FA404550X12	FA404550X12
32	Diaphragm Support (Not Shown)	1	-----	GF01934X012	-----	GF01934X012
38*	Spring (Mini)	1	See Table 3	See Table 3	See Table 3	See Table 3
40*	Adjustable Screw (Mini)	1	ERAA05947A0	ERAA05947A0	ERAA05947A0	ERAA05947A0
41*	Spring (Maxi)	1	See Tables 2 and 3	See Tables 2 and 3	See Tables 2 and 3	See Tables 2 and 3
42*	Maxi washer	1	GF01925X012	GF01925X012	GF01925X012	GF01925X012
44*	Fastening clip	1	GF04079X012	GF04079X012	-----	-----
46*	O-ring Pd (54.00x2.00)	1	GF03443X012	GF03443X012	GF03443X012	GF03443X012
47*	Safety Plug	1	GF01940X012	GF01940X012	ERAA05852A0	ERAA05852A0
48*	Vent	1	27A5516X012	27A5516X012	27A5516X012	27A5516X012
50*	O-ring (2.00x1.25)	1	GF03449X012	GF03449X012	GF03449X012	GF03449X012
51*	Sense Blocking Screw	1	GF02261X012	GF02261X012	GF02261X012	GF02261X012
53*	Cotter Pin	4	-----	-----	ERAA05924A0	ERAA05924A0
58*	Retainer Nut	1	-----	-----	ERAA05875A0	ERAA05875A0
93	O-ring R8 (10.82x1.78)	----	-----	-----	-----	-----
96	Nut M2.5X0.45	----	-----	-----	-----	-----
102	Ring Guide	----	-----	-----	-----	-----
103*	Washer	1	ERAA05957A0	ERAA05957A0	ERAA05957A0	ERAA05957A0
104*	Maxi Seat	1	ERAA05956A0	ERAA05956A0	ERAA05956A0	ERAA05956A0

1. When adjusting the controller, refer to the Controller Spring Range tables, Tables 2 and 3, to ensure the desired set value is achievable for the controller construction.
 *Recommended Spare Part

VSX4 and VSX8 Series

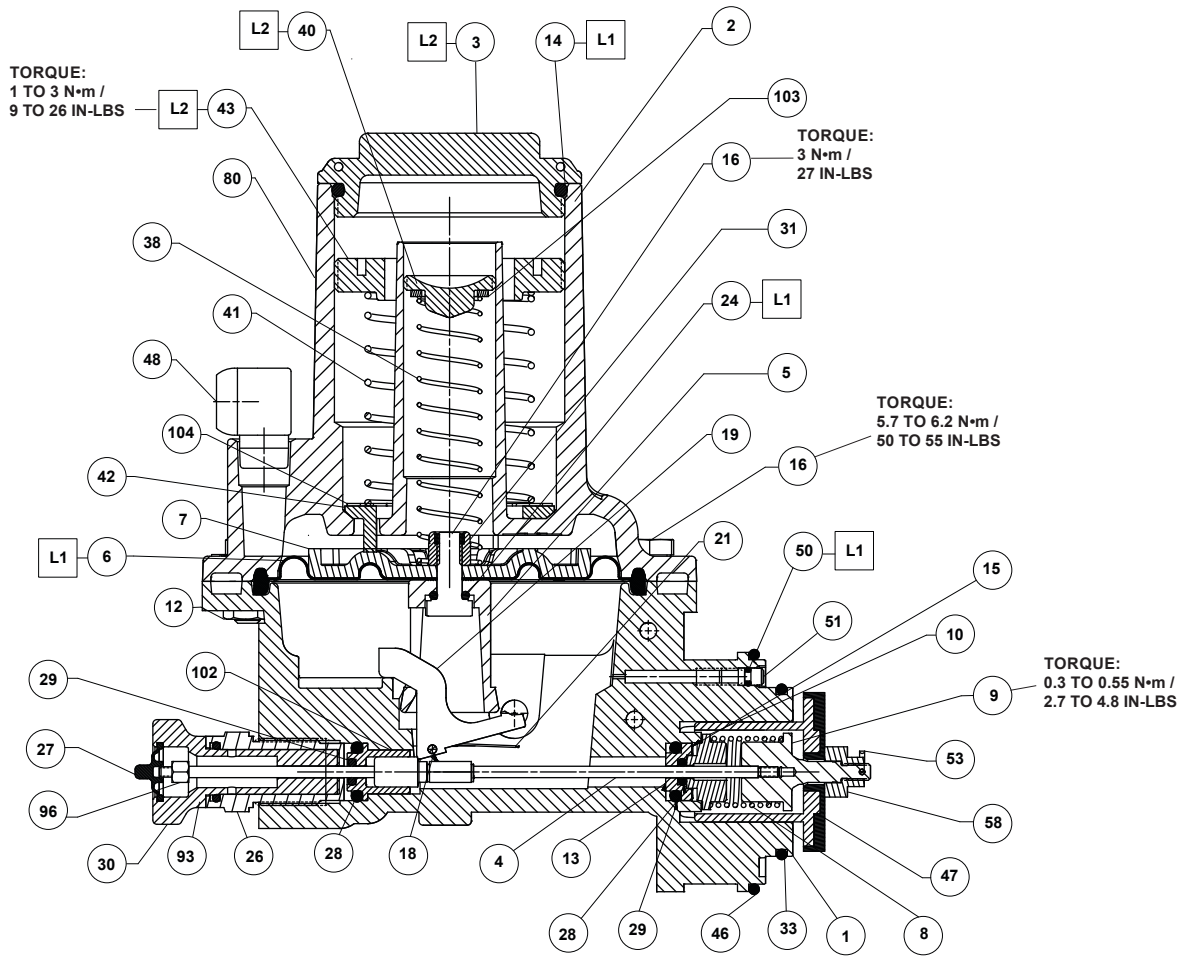

VSX8 SERIES

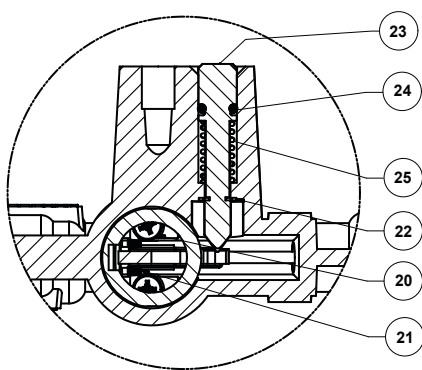

MANUAL BUTTON

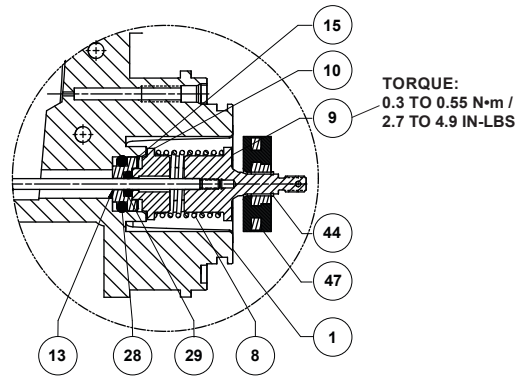

VSX4 SERIES

ERCA02667

- APPLY LUBRICANT⁽¹⁾:
L1 = MULTI-PURPOSE PTFE LUBRICANT
L2 = ANTI-SEIZE LUBRICANT

1. Lubricants must be selected such that they meet the temperature requirements.

Figure 15. Controller Assembly

VSX4 and VSX8 Series

Parts List (continued)

VSX4 AND VSX8 SERIES KIT					
Key	Quantity	Code	Description	Part Number	
				Type VSX4L/VSX8L	Type VSX4H/VSX8H
Modification Kit to Change from Internal to External Sense					
50	1	197898	Sense blocking O-ring (2.00 x 1.25) (for external only)	GF03449X012	
51	1		Sense blocking screw (for external only)	GF02261X012	
Diaphragm Replacement Kit					
6	1	197899	Diaphragm	GF01929X012	
31	1		Lock nut	FA404550X12	
Modification Kit to Change from Low Pressure to High Pressure Construction					
7	1	197900	Diaphragm plate	-----	GF01944X012
32	1		Diaphragm support	-----	GF01934X012
14	1		Closing cap O-ring	GF03448X012	
31	1		Lock nut	FA404550X12	
+ spring				<i>according to setpoint -- not included in the kit</i>	
Modification Kit to Change from High Pressure to Low Pressure Construction					
7	1	197901	Diaphragm plate	GF01927X012	-----
14	1		Closing cap O-ring	GF03448X012	
31	1		Lock nut	FA404550X12	
+ spring				<i>according to setpoint -- not included in the kit</i>	
VSX4 Series Repair Kit					
6	1	RVSX4MCX012	Diaphragm	GF01929X012	
14	1		Closing cap O-ring	GF03448X012	
24	1		Diaphragm Assembly O-ring	GF03445X012	
31	1		Lock nut	FA404550X12	
33	1		Inlet O-ring	GF03442X012	
46	1		Outlet O-ring	GF03443X012	
47	1		Medium Capacity Disk	GF01940X012	
VSX8 Series Repair Kit					
6	1	RVSX8X00012	Diaphragm	GF01929X012	
14	1		Closing cap O-ring	GF03448X012	
24	1		Diaphragm Assembly O-ring	GF03445X012	
31	1		Lock nut	FA404550X12	
33	1		Inlet O-ring	GF03442X012	
46	1		Outlet O-ring	GF03443X012	
47	1		High Capacity Disk	ERAA05852A0	
53	1		Cotter Pin	ERAA05924A0	

✉ Webadmin.Regulators@emerson.com

📘 [Facebook.com/EmersonAutomationSolutions](https://www.facebook.com/EmersonAutomationSolutions)

🔍 Fisher.com

🌐 [LinkedIn.com/company/emerson-automation-solutions](https://www.linkedin.com/company/emerson-automation-solutions)

🐦 [Twitter.com/emr_automation](https://twitter.com/emr_automation)

Emerson Automation Solutions

Americas

McKinney, Texas 75070 USA
T +1 800 558 5853
+1 972 548 3574

Asia Pacific

Singapore 128461, Singapore
T +65 6777 8211

Europe

Bologna 40013, Italy
T +39 051 419 0611

Middle East and Africa

Dubai, United Arab Emirates
T +971 4 811 8100

D103127X012 © 2009, 2018 Emerson Process Management Regulator Technologies, Inc. All rights reserved. 05/18.
The Emerson logo is a trademark and service mark of Emerson Electric Co. All other marks are the property of their prospective owners. Fisher™ is a mark owned by Fisher Controls International LLC, a business of Emerson Automation Solutions.

The contents of this publication are presented for information purposes only, and while effort has been made to ensure their accuracy, they are not to be construed as warranties or guarantees, express or implied, regarding the products or services described herein or their use or applicability. All sales are governed by our terms and conditions, which are available on request. We reserve the right to modify or improve the designs or specifications of our products at any time without notice.

Emerson Process Management Regulator Technologies, Inc does not assume responsibility for the selection, use or maintenance of any product. Responsibility for proper selection, use and maintenance of any Emerson Process Management Regulator Technologies, Inc. product remains solely with the purchaser.



The distinctive swirl pattern cast into every actuator casing uniquely identifies the regulator as part of the Fisher™ brand Commercial Service Regulator family and assures you of the highest-quality engineering, performance, and support traditionally associated with Fisher™ and Tartarini™ regulators. Visit www.fishercommercialservice.com to access interactive applications.

