



Dival 500

Pressure Regulators

Pressure regulators

Dival 500

- The DIVAL 500 series of spring loaded, diaphragm controlled, balanced valve design regulators are suitable for low, medium and high outlet pressure.
- Dival 500 regulators are supplied with internal sensing lines and are preset for an optional connection to an external sensing line by the customer.
- They are widely used in both commercial and industrial installations using Natural Gas, LPG and other non corrosive gases.
- The special regulator design combined with a balanced valve results in:
 - high flow rate coefficient,
 - high accuracy, even at maximum flow rates,
 - reduced lock up pressure zone and lock up pressure,
 - reduced response times, - no internal leakage at zero flow rate,
 - fail to open type,
 - periodical maintenance without disassembling the body from the pipework,
 - ability to retrofit the slam-shut OPSO/UPS0, (only LA model) without modifying the existing piping.

HIGHT PERFORMANCE

- Balanced valve design provides increased capacity, high 500:1 turndown and table regulation from low to high flow.
- Complete lockup in absence of gas flow, bubble tight shut-of.
- Balanced Valves Design allows the regulator inlet pressure to change but the regulators outlet pressure holds setpoint.

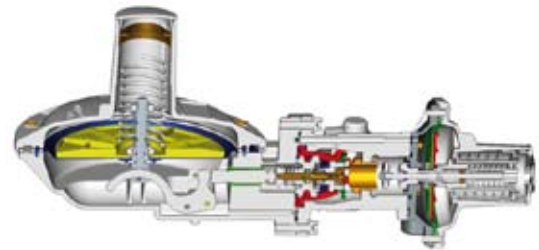

INSTALLATION SAVING

- Integral sensing line and optional external sensing line
- No need to change the orifice
- Fixing holes

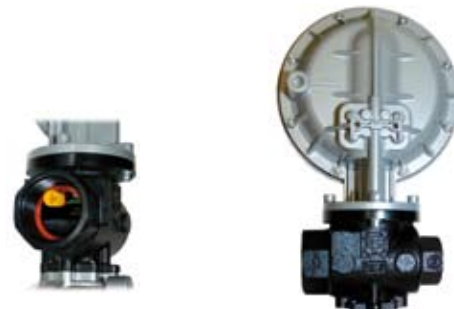

**DESIGNED
WITH YOUR
NEEDS IN MIND**

- COMPACT DESIGN
- EASY MAINTENANCE
- BALANCED DESIGN
- FAST RESPONSE TIME
- HIGH TURN DOWN RATIO
- HIGH ACCURACY
- FIXED OREFICE
- WIDE RANGE OF APPLICATIONS

INCORPORATED SHUT-OFF DEVICE**Dival 500**

This is an optional device which stops immediately gas flow whenever downstream pressure exceeds given set-point.

The device operates in the following cases:

- Over pressure - in case the monitoring pressure exceeds the calibration limits.
- Under pressure - in case the monitoring pressure goes below the calibration limits (the calibration changes from the outside according to the spring in use).

High flexibility & modularity

The Dival 500 regulators can be supplied or retrofitted with two optional models of incorporated shut-off devices

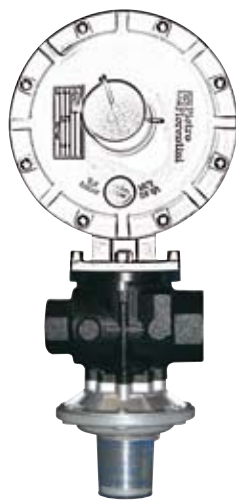
DIVAL 500 + SHUT-OFF DEVICE**Dival 500****LE type**

Design pressure PS: 10 bar

**LA type**

Design pressure PS: 20 bar

INCORPORATED RELIEF VALVE

Dival 500

The Dival 500 series is provided with an incorporated token relief valve, discharging gas to the atmosphere whenever the pressure on the outlet of the regulator exceeds the set value. The events that can generate the opening of the valve are:

- Thermal expansion of the gas in downstream while there is no flow condition
- Pressure peaks owed to quick closing of the valve downstream (in case of small volumes)
- Unperfect lock-up at zero flow rate

When the outlet pressure returns at a value below the set value the relief valve returns in closed position.

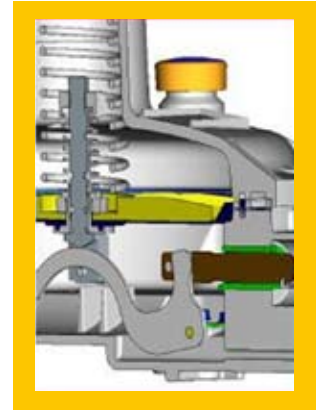

VS/AM 65

Dival 500

The Dival 500 can be installed in combination with an external VS/AM 65 venting device.

Main features:

- Available size: 1"
- Temperature class: -20°C + 60°C
- Max inlet pressure: 20 bar

VS/AM 65 Relief Pressure

Model	Relief pressure range
BP	0.15 mbar - 0.15 bar
MP	0.15 bar - 0.5 bar
TR	0.5 bar - 7 bar

External Relief Valve

- Reduced overpressures
- Easy maintenance
- Fast response
- Internal sensing line
- High setting pressures available
- Sealed access to the setting spring (optional)



VS/AM 65
External relief

MAIN FEATURES
Dival 500

Available sizes: 1"x1" ISO 7/1; 1"x1"1/2 ISO 7/1

Optional: incorporated shut-off device

Max OP. Pres.: 10 bar BP Model - 20 bar MP & TR Models

Temperature class: -20°C - + 60°C (-4 to + 140°F)

Model	Inlet pressure range	Outlet pressure range
BP	0.5 bar - 10 bar	15 mbar - 0.1 bar
MP	0.5 bar - 20 bar	15 mbar - 0.1 bar
TR	0.5 bar - 20 bar	15 mbar - 0.1 bar

MATERIALS
Dival 500

Body	Cast iron
Covers	Die cast Aluminum
Rubber parts	NBR
Diaphragm	Cloth rubber

Capacity Tables

Dival 500

DIVAL 500 1" WITH INTERNAL WITH PRESETTING EXTERNAL SENSING LINE

Pd:15-100mbar BP Flow rate stmc/h G.N.				Pd:100-300mbar MP Flow rate stmc/h G.N.				Pd:300-1000mbar MP Flow rate stmc/h G.N.				Pd:1000-3000mbar BP Flow rate stmc/h G.N.			
Pu bar	AC5	AC10	AC20	Pu bar	AC5	AC10	AC20	Pu bar	AC5	AC10	AC20	Pu bar	AC5	AC10	AC20
Pd +0,5 bar	75	95	105	Pd +0,5 bar	110	130	140	Pd +0,5 bar	50	80	100	Pd +0,5 bar	100	160	200
Pd +1 bar	75	125	140	Pd +1 bar	150	180	200	Pd +1 bar	75	130	150	Pd +1 bar	150	270	300
Pd +2,5 bar	100	125	140	Pd +2,5 bar	250	300	300	Pd +2,5 bar	120	200	250	Pd +2,5 bar	300	480	500
Pd +5,0 bar	90	140	160	Pd +5,0 bar	300	300	300	Pd +5,0 bar	130	350	350	Pd +5,0 bar	350	350	350

DIVAL 500 1" WITH INTERNAL AND EXTERNAL SENSING LINE ACTIVE*

Pd:15-100mbar BP Flow rate stmc/h G.N.				Pd:100-300mbar MP Flow rate stmc/h G.N.				Pd:300-1000mbar MP Flow rate stmc/h G.N.				Pd:1000-3000mbar BP Flow rate stmc/h G.N.			
Pu bar	AC5	AC10	AC20	Pu bar	AC5	AC10	AC20	Pu bar	AC5	AC10	AC20	Pu bar	AC5	AC10	AC20
Pd +0,5 bar	50	75	100	Pd +0,5 bar	100	140	150	Pd +0,5 bar	50	80	100	Pd +0,5 bar	100	160	200
Pd +1 bar	75	140	150	Pd +1 bar	140	100	230	Pd +1 bar	75	130	150	Pd +1 bar	150	270	300
Pd +2,5 bar	120	205	240	Pd +2,5 bar	200	300	300	Pd +2,5 bar	120	200	250	Pd +2,5 bar	300	480	500
Pd +5,0 bar	140	250	300	Pd +5,0 bar	350	350	350	Pd +5,0 bar	130	350	350	Pd +5,0 bar	350	350	350

* Connection to the external sensing line by the client

DIVAL 500 1" 1/2 WITH INTERNAL WITH PRESETTING EXTERNAL SENSING LINE

Pd:15-100mbar BP Flow rate stmc/h G.N.				Pd:100-300mbar MP Flow rate stmc/h G.N.				Pd:300-1000mbar MP Flow rate stmc/h G.N.				Pd:1000-3000mbar BP Flow rate stmc/h G.N.			
Pu bar	AC5	AC10	AC20	Pu bar	AC5	AC10	AC20	Pu bar	AC5	AC10	AC20	Pu bar	AC5	AC10	AC20
Pd +0,5 bar	75	100	110	Pd +0,5 bar	120	150	170	Pd +0,5 bar	60	90	110	Pd +0,5 bar	110	160	200
Pd +1 bar	160	180	200	Pd +1 bar	170	250	280	Pd +1 bar	75	140	160	Pd +1 bar	180	350	400
Pd +2,5 bar	140	200	200	Pd +2,5 bar	250	380	400	Pd +2,5 bar	160	250	280	Pd +2,5 bar	320	500	500
Pd +5,0 bar	130	160	180	Pd +5,0 bar	300	400	450	Pd +5,0 bar	350	450	500	Pd +5,0 bar	350	500	500

DIVAL 500 1" 1/2 WITH INTERNAL AND EXTERNAL SENSING LINE ACTIVE*

Pd:15-100mbar BP Flow rate stmc/h G.N.				Pd:100-300mbar MP Flow rate stmc/h G.N.				Pd:300-1000mbar MP Flow rate stmc/h G.N.				Pd:1000-3000mbar BP Flow rate stmc/h G.N.			
Pu bar	AC5	AC10	AC20	Pu bar	AC5	AC10	AC20	Pu bar	AC5	AC10	AC20	Pu bar	AC5	AC10	AC20
Pd +0,5 bar	70	110	115	Pd +0,5 bar	100	160	180	Pd +0,5 bar	60	90	110	Pd +0,5 bar	110	160	200
Pd +1 bar	160	170	150	Pd +1 bar	160	240	280	Pd +1 bar	75	140	160	Pd +1 bar	180	350	400
Pd +2,5 bar	300	350	350	Pd +2,5 bar	500	500	500	Pd +2,5 bar	160	250	280	Pd +2,5 bar	320	500	500
Pd +5,0 bar	200	250	300	Pd +5,0 bar	500	500	500	Pd +5,0 bar	350	450	500	Pd +5,0 bar	350	500	500

*Connection to the external sensing line by the client

LPG flow rate:

- multiply the value in the table x 1.2

Azote flow rate:

- multiply the value in the table x 0.789

LEGEND:

- Pd: Outlet pressure

- Pu: Inlet pressure

- Ac: Accuracy

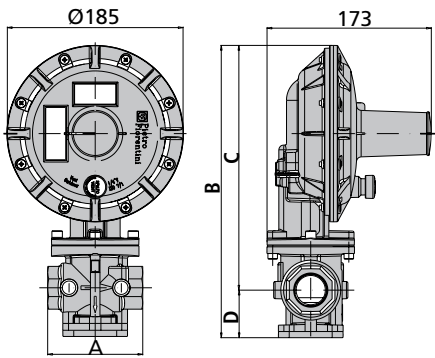
DIMENSIONS
Dival 500

Dival 500

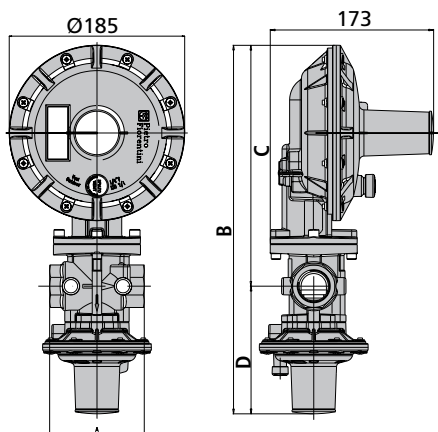
	Dival 500 1" x 1"	Dival 500 1" x 1 1/2"
A	100±1	130±1
B	299	307
C	255±1	257±1
D	44	50
DnE	1" ISO 7/1	1" ISO 7/1
DnU	1" ISO 7/1	1 1/2 ISO 7/1

Dival 500 + LE

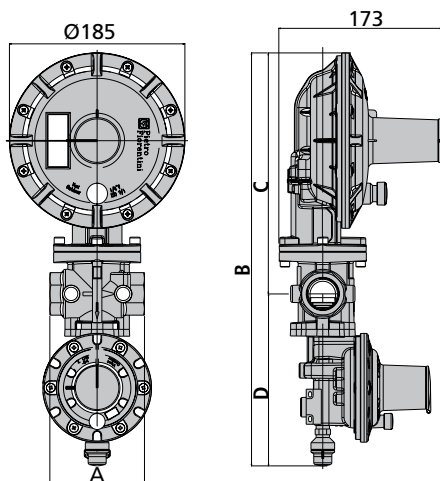
	Dival 500+LE 1" x 1"	Dival 500+LE 1" x 1 1/2"
A	100±1	130±1
B	390±2	398±2
C	255±1	257±1
D	135±1	141±1
DnE	1" ISO 7/1	1" ISO 7/1
DnU	1" ISO 7/1	1 1/2 ISO 7/1

Dival 500 + LA

	Dival 500+LA 1" x 1"	Dival 500+LA 1" x 1 1/2"
A	100±1	130±1
B	437±2	445±2
C	255±1	257±1
D	182±1	188±1
DnE	1" ISO 7/1	1" ISO 7/1
DnU	1" ISO 7/1	1 1/2 ISO 7/1

Overall dimensions in inches



Reducing Stations



Metering



Butterfly Valves



**Pietro
Fiorentini**

Pietro Fiorentini S.p.A.
via E.Fermi 8/10
I-36057 Arcugnano (VI) Italy

Tel. +39 0444 968.511
Fax. +39 0444 960.468

The data are not binding. We reserve the right to make eventual changes without prior notice.

CT-s 552-E December 10

www.fiorentini.com