

Series 16 Modules Controls – Solid State Plug-In Modules

- ▶ Compact Size
- ▶ Modular Plug-in Design
- ▶ Various Time Delays
- ▶ Low Voltage Sensor
- ▶ Solid State Reliability
- ▶ LED Monitoring
- ▶ U.L. “Motor Control”

Series 16M – General Purpose Control

- New Microprocessor Design

Designed for either differential or single-level service. U.L. “Motor Controller” listing, 8 pin socket with screw-type connections make the unit easy to install and service. Sensitivity of up to 1 million ohm/cm.

Series 16HM – High Sensitivity Control

Series 16HM is similar to Series 16M but provides higher sensitivity up to 5.5 million ohm/cm. Probe voltage is 12 VDC for applications with low conductive media.

Series 16DM – DPDT Load Contact

Similar to Series 16M but with DPDT load contacts. Eliminates the need for slave relays. 11 pin octal plugs. Requires little panel space. General purpose single-level or differential applications. U.L. listed.

Series 16VM – Field Selectable Sensitivity

Similar to Series 16M but with the added flexibility of field adjustable sensitivity, made possible through external setpoint resistors. Uses 11pin octal socket. U.L. listed.

Specifications

Contact Design	
Series 16M & 16HM	1 N.O. & 1 N.C. (1 form C)
Series 16DM	2 N.O. & 2 N.C. (2 form C)
Series 16VM	1 N.O. & 1 N.C. (1 form C)
Contact Rating (120. 240 VAC)	
Series 16M & 16HM	10 amp Resistive 1/3 hp
Series 16DM	5 amp Resistive 1/10 hp
Series 16VM	10 amp Resistive 1/3 hp
Mode of Operation	Direct/Inverse, factory set
Sensitivity	
Series 16M	0-1M ohm, factory set
Series 16HM	0-5.5M ohm, factory set
Series 16DM	0-1M ohm, factory set
Series 16VM	0-1M ohm, field adjustable
Primary Voltage	24 VAC, 120 VAC, 240 VAC (+10%/-15%) 208/240: 187 V min. to 255 V max. VAC 50/60 Hz
Secondary Voltage	
Series 16M	12 VAC, 1.5 mA
Series 16HM	12 VDC
Series 16DM & 16VM	12 VAC, 1.5 mA
Temperature	-40°F to +150°F (-40°C to +65°C)
Approvals	U.L. 508 File #E44426
Terminal Style	Screw connector
Options	Time Delays



Series 16M/16HM

Series 16DM/16VM

Applications

- Single-Level Service
- Point Level
- Valve Control
- Differential Service
- Alarms
- Pump Control

Dimensions

Series 16M & 16HM

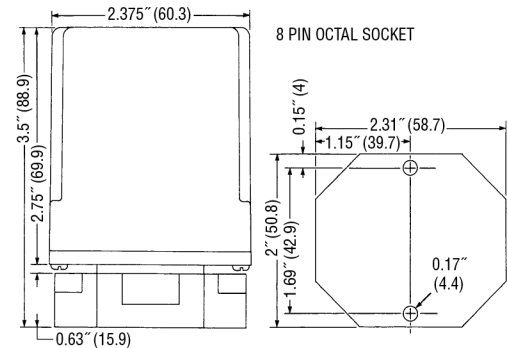

Series 16DM & 16VM

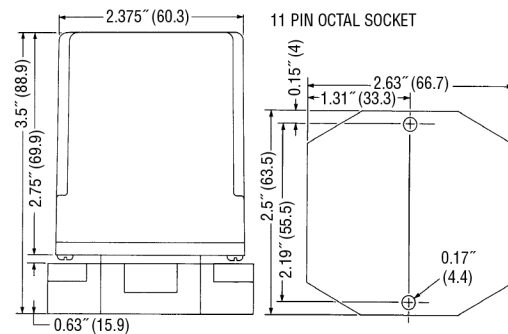

Note: Controls also available with DIN mount socket.

WARRICK CONDUCTIVITY SENSORS

Wiring

Series 16M & 16HM

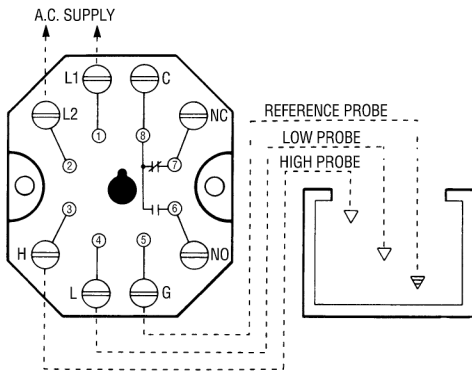

Note: For single level service, use "H" and "G" connections.

Series 16DM

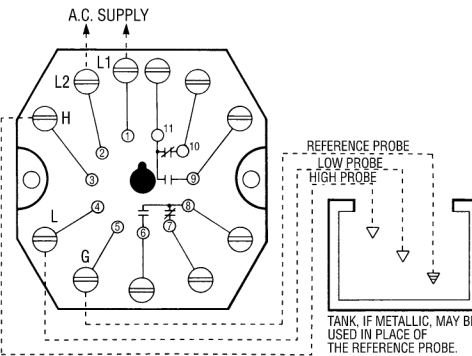

Series 16VM

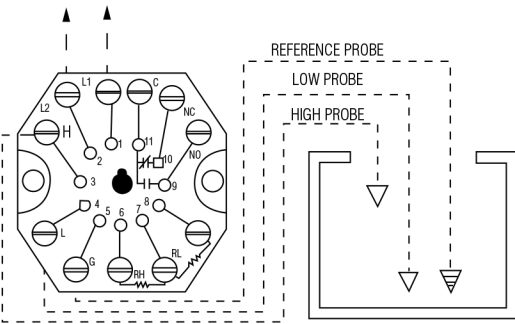

Variable Sensitivity Option

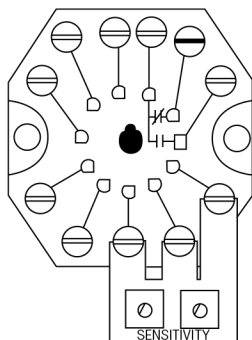

Part number 16Z1VG Potentiometer Board available for 16VM only. Consult factory.

How to Order

Use the **Bold** characters from the chart below to construct a product code.

16M Series – Microprocessor Version

	16M	X	X	X	X	X	XX	XX
1. Series	_____							
	16M General Purpose;							
2. Mode of Operation	_____							
	Direct				Inverse			
	A – 4.7K	E – 100K	K – 4.7K	P – 100K	L – 10K	R – 470K	S – 1M	
	B – 10K	F – 470K	M – 26K	N – 50K				
	C – 26K	G – 1M						
	D – 50K							
3. Supply Voltage	_____							
	1 120 VAC; 2 240 VAC; 3 24 VAC; 8 208/240 VAC							
4. Socket Style*	_____							
	A 8 Pin Octal				M Module Only			
	B 8 Pin DIN							
5. Enclosure	_____							
	0 None; 1 NEMA 1; 4 NEMA 4							
6. Time Delay (increasing level) Option	_____							
	00-90 seconds							
	Blank 0 seconds							
7. Time Delay (decreasing level) Option	_____							
	00-90 seconds							
	Blank 0 seconds							
8. Time Out Option	_____							
	See page E-11, Chart A							

*See page E-11 for descriptions.

16 HM, 16DM or 16VM Series

	16HM	X	X	X	X	XX	XX
1. Series	_____						
	16HM High Sensitivity;						
	16DM DPDT Load Contact;						
	16VM Field Selectable Sensitivity ¹						
2. Mode of Operation ²	_____						
	Direct			Inverse			
	A – 4.7K ⁴	F – 470K ⁴	K – 4.7K ⁴	R – 470K ⁴	L – 10K ⁴	S – 1M ⁴	
	B – 10K ⁴	G – 1M ⁴	M – 26K ⁴	T – 3M ³	N – 50K ⁴	W – 5.5M ³	
	C – 26K ⁴	H – 3M ³	J – 5.5M ³	P – 100K ⁴	Y – 0-700K ^{5,7}	Z – 0-700K ^{5,7}	
	D – 50K ⁴						
	E – 100K ⁴						
3. Supply Voltage	_____						
	1 120 VAC; 2 240 VAC; 3 24 VAC; 8 208/240 VAC						
4. Socket Style	_____						
	A 8 Pin Octal (16M & 16HM), 11 Pin Octal (16DM & 16VM);						
	B DIN Mount; M None, Module Only ⁶						
5. Enclosure	_____						
	0 None; 1 NEMA 1; 4 NEMA 4						
6. Time Delay (increasing level) Option	_____						
	01-20 seconds; 0V variable (16VM only)						
7. Time Delay (decreasing level) Option	_____						
	01-20 seconds; 0V variable (16VM only)						

Notes:

- 16VM select modes **A**, **K**, **Y** or **Z** only.
- 16HM & 16DM only. Series 16VM includes full set of the resistors listed above. Specify a sensitivity to determine mode of operation.
- 16VM only.
- All Series except 16HM.
- 16VM only.
- Socket style M requires enclosure **0** – None.
- Mounting style A (11 pin octal only)

Socket Details and Option Availability are located on web site.

Optional Character Reference – 16, 26 and DF Series Only

Manual Reset

Available on Series 26, 26M and DF controls

(Normally closed pushbutton across reset terminals. Pushbutton ordered separately): Manual reset only applies to the function associated with terminal LLCO. When the liquid rises to the electrode on terminal LLCO, the control will remain de-energized (load contacts in original state) until the pushbutton is depressed. The control will then energize, (LED will be lit) changing the state of the contacts. The control remains energized until the liquid level recedes below electrode on terminal LLCO. The control then de-energizes, (LED will go off) returning load contacts to their original state. Unless otherwise specified, there is a three second time delay on decreasing level. Liquid must be below probe on terminal LLCO for full three seconds before control de-energizes.

Manual Reset with Power Outage Feature

Available on Series 26, 26M, and DF controls

Reset (Normally closed pushbutton across reset terminals. Pushbutton ordered separately) Control will ignore power loss to control. With liquid in contact with electrode on terminal LLCO, a power outage will cause the control to de-energize, but will automatically energize upon return of power. However, loss of liquid will cause control to de-energize and remain so until liquid again rises to electrode and pushbutton is depressed.

Time Delays Associated with Terminals H and L

Available on Series 16, 16M, and DF controls

With time delay on increasing level, the liquid must be in contact with the high electrode for the full duration of the time delay before control will operate. With delay on decreasing level, the liquid must be below the low electrode for the full duration of the time delay before control will operate. In single level service, terminals 3 and 4 must be jumpered together to achieve time delays on both increasing and decreasing levels or just decreasing level.

Time Delays Associated with Terminal LLCO

Available on Series 26, 26M, and DF controls

3 Second time delay on decreasing level is standard. Delay up to 90 seconds, can be specified and would act in the same manner as listed above.

Time Out Option

Available on Series 16, 16M, and DF controls

The latching circuit for the high and low electrode has an optional timer. In some applications the High or Low electrode may become short circuited or disconnected. Such an occurrence may potentially over fill in fill applications, or cause the pump to run dry in pump down applications. The time option is custom programmed up to 3 minutes. When a fault condition occurs, the FILL LED will have a blink sequence of .5 seconds on 2 seconds off. See Chart A for time delay options.

Test Feature

Available on Series 26, 26M, and DF controls

Allows LLCO circuit to be tested. Holding down the reset button for 3 seconds will allow the LLCO circuit to trip which simulates the loss of water, without the need of draining the water level in the boiler. The control will return to normal operation once the reset button is pressed a second time. (Test feature option only available with the manual reset function.)

Chart A – Time Out Option

Optional Character	Time Out (in seconds)					
	30	60	90	120	150	180
K	•					
L		•				
M			•			
N				•		
P					•	
Q						•

Chart B – Optional Character Information

Reset Function	Option Components				Control Series	Optional Character
	Normally Closed Pushbutton*	Power Outage	Retrofit Plate	Test Feature		
•					DF "LLCO"	D
•	•				26, 26M, 26NM	C
•		•			26, 26M, 26NM	E
•			•		16, 16D, 26, DF	R
•	•				DF "LLCO"	S
•		•			DF "LLCO"	K
•			•		DF	W
•				•	26, 26M, 26NM, DF"LLCO"	B
•	•	•			26, 26M, 26NM	F
•		•	•		26	N
•	•	•			DF "LLCO"	G
•	•		•		DF	T
•	•			•	26, 26M, 26NM, DF"LLCO"	Y
•		•	•		DF	L
•		•		•	26, 26M, 26NM, DF"LLCO"	Z
•	•	•	•		26	P
•	•	•	•		DF	J
•	•	•		•	26, 26M, 26NM, DF"LLCO"	A
No options						X

* N.C. pushbutton when purchased in conjunction with open control must be remotely mounted by customer