

LS200 Series Direct-Operated Regulators



Figure 1. LS200 Series Direct-Operated Regulators

Features

- **Wide Pressure Range Capability with Single Regulator** - Up to 60 psi / 4.1 bar outlet pressure.
- **Suitable for Monitoring Applications** - Pair the LS200 Series with pilot operated regulator in a monitor application for spring open and spring closed.
- **Excellent Shock Characteristics and Fast Speed of Response** - Due to two-way stabilizer vent valve, which vents the spring case more rapidly than conventional vents, lag in diaphragm and valve disk movement is minimized.
- **Suitable for Hydrogen Applications** - Contact your local sales channel or Emerson Impact Partner for more details on Hydrogen configurations.
- **Bubble-Tight Shutoff** - Single-port construction, large diaphragm area, light-rate springs along with ideal durometer disk material and seat design provide low lock-up pressures.
- **Change Elastomer Disk without Disassembling the Actuator** - Hex shaped stem allows for disk removal without holding the stem during maintenance. Eliminates the chance of damaging the diaphragms during maintenance.
- **No Seat-to-Seat Adjustment Required** - Balanced single-port design eliminates necessity for seat-to-seat adjustments to achieve bubble-tight shutoff.

LS200 Series

Specifications

The Specifications section lists the specifications for the LS200 Series direct-operated regulators. Factory specification is stamped on the nameplate fastened on the regulator at the factory.

Actuator Sizes

Types LS220 and LS224 (350 mm): Medium pressure construction for outlet pressure range of 4.35 to 10 psig / 0.3 to 0.69 bar. Maximum operating inlet pressure of 125 psi / 8.61 bar. Medium Pressure for outlet range of 10 to 21.75 psi / 0.69 to 1.5 bar has a maximum operating inlet up to 284 psig / 19.6 bar. The maximum operating and emergency inlet pressure rating is 284 psig / 19.6 bar.

Types LS250 and LS254 (255 mm): High pressure construction for outlet pressure range of 20 to 60 psig / 1.38 to 4.14 bar. The maximum operating inlet pressure is 284 psig / 19.6 bar with a maximum emergency inlet pressure of 284 psig / 19.6 bar.

Outlet Pressure Ranges⁽¹⁾

See Table 2

Pressure Ratings⁽¹⁾

See Table 2

Maximum Outlet Pressure⁽¹⁾

See Table 3

Wide Open Flow Coefficients

See Tables 4

Certifications

EN 334, EN 14382 and
Pressure Equipment Directive (PED)
DVGW
Up to 25% Hydrogen Blend (Pending 100%)
V9 Certifications

Pressure Registration

External; downstream control line is required

Temperature Capabilities⁽¹⁾⁽²⁾

-20 to 150°F / -29 to 66°C /
-4 to 140°F / -20 to 60°C / for PED
Lockup and Function Tested to -40°F / -40°C

Control Line Connection

Without Slam-Shut: 1/4 NPT (internal); connection will be positioned directly over body outlet (standard position) or 90 degrees right or left of standard position if specified.

With Slam-Shut: 1/4 NPT (internal) connection right or left directly over slam-shut. Can be selected or changed after shipment.

Vent Connection

3/4 NPT (internal) vent assembly.

Approximate Weight

Body

NPT: 26.5 lbs / 12 kg
2x2: 30.4 lbs / 13.5 kg
2x4: 38.7 lbs / 17.55 kg

Slam-Shut Device: 16.4 lbs / 7.45 kg

Types LS220 and LS224 Actuator:
61.1 lbs / 27.7 kg (Eye nuts included)

Types LS250 and LS254 Actuator:
44.9 lbs / 20.35 kg (Eye nuts included)

1. The pressure/temperature limits in this Bulletin or any applicable standard limitation should not be exceeded.

2. Using optional restriction collar.

- **Easy Access to Trim Parts** - Change the valve disk in 30 minutes or less. Valve seat, disk, and cage easily removed with body remaining in line and without disassembly of actuator portion. Disk is accessible from bottom flange.
- **Reusable Pressure Seals** - O-rings used for pressure seals, unlike gaskets, are not ordinarily damaged by disassembling the regulator.
- **Resistance to Piping Stresses** - Steel constructions are available to help resist pipe stresses.

Table 1. Available Configurations

TYPE NUMBER				OPTION			
L	S	2					
				PRESSURE CONSTRUCTION			
0				Low Pressure Applications (<i>In Development</i>)			
2				Medium Pressure Applications (<i>Outlet Pressure: 4.35 to 21.75 psig / 0.3 to 1.5 bar</i>)			
5				High Pressure Applications (<i>Outlet Pressure: 20 to 60 psig / 1.38 to 4.14 bar</i>)			
				OVERPRESSURE PROTECTION			
0				Without Overpressure Protection Module			
4				With Slam-shut Module ⁽¹⁾			
Example: Type number LS224: LS200 Series regulator constructed for medium pressure applications, with Type VSX4 slam-shut module and external pressure registration. 1. Reference Instruction Manual D103127X012 for Type VSX8 safety slam-shut module.							

Table 2. LS200 Series Outlet Pressure Ranges, Control Springs

TYPE	ACTUATOR DIAMETER SIZE, mm	SPRING RANGE		PART NUMBER	CONTROL SPRING		COLOR
		psig	bar		WIRE DIAMETER		
					In.	mm	
LS220 and LS224	350	4.35 to 5.1	0.3 to 0.35	ERAA07586A0	8.5	0.312	Light Green
		4.35 to 10.6	0.3 to 0.73	ERAA07589A0	10.5	0.406	Pink
		4.8 to 15.7	0.33 to 1.08	ERAA07283A0	12	0.438	Dark Blue
		8.3 to 21.75	0.57 to 1.5	ERAA07283A0	12.5	0.5	Orange
LS250 and LS254	255	20 to 30.3	1.38 to 2.09	ERAA07589A0	10.5	0.406	Pink
		20 to 44.8	1.38 to 3.09	ERAA07592A0	12	0.438	Dark Blue
		25 to 60	1.72 to 4.14	ERAA07283A0	12.5	0.5	Orange

Table 3. Maximum Inlet and Outlet Pressures

PRESSURE		TYPE LS220		TYPE LS250	
		psig	bar	psig	bar
Maximum Operating Inlet Pressure	<10 psi / 0.69 bar max outlet pressure	125	8.61	----	----
	>10 psi / 0.69 bar max outlet pressure	284	19.6	284	19.6
Maximum Emergency Inlet Pressure		284	19.6	284	19.6
Maximum Operating Outlet Pressure ⁽¹⁾		21.7	1.5	60	4.13
Maximum Outlet Pressure Over Outlet Pressure Setting		28.9	1.99	83.7	5.77
Maximum Emergency Outlet (Casing) Pressure		50	3.44	150	10.34

1. With highest spring range available only.

Table 4. Wide Open Flow Coefficients

UNIT INFORMATION			FLOW COEFFICIENTS		
Regulator	Body	Type	C _g	C ₁	C _v
LS200 Series	2x2	LS220 and LS250	2083	29	72
	2x4		2461	33	74
	2x2	LS224 and LS254 with SSD	2001	28	28
	2x4		2304	34	67

LS200 Series

Table 5. Pressure Ranges and Body Pressure-Temperature Ratings Without PED Certification

TYPE	OUTLET RANGE		BODY MATERIAL	END CONNECTION	TEMPERATURE RANGE		MAX OPERATING INLET		MAX BODY PRESSURE RATING			
	psig	bar			'F	'C	psig	bar	psig	bar		
LS220 and LS224	4.35 to 10	0.3 to 0.69	Ductile iron	PN 16	-20 to 100	-29 to 38	125	8.6	232	16	232	16
					-20 to 150	-29 to 66						
				CL150 RF	-20 to 100	-29 to 38						
					-20 to 150	-29 to 66						
			Steel	PN 16	-20 to 100	-29 to 38						
					-20 to 150	-29 to 66						
				CL150 RF	-20 to 100	-29 to 38						
					-20 to 150	-29 to 66						
			NPT	-20 to 100	-29 to 38							
				-20 to 150	-29 to 66							
			Cast iron	CL125 FF	-20 to 100	-29 to 38						
					-20 to 150	-29 to 66						
NPT	-20 to 100	-29 to 38										
	-20 to 150	-29 to 66										
LS220 and LS224	10 to 21.7	0.69 to 1.5	Ductile iron	PN 16	-20 to 100	-29 to 38	232	16	232	16	232	16
					-20 to 150	-29 to 66						
				CL150 RF	-20 to 100	-29 to 38						
					-20 to 150	-29 to 66						
			Steel	PN 16	-20 to 100	-29 to 38						
					-20 to 150	-29 to 66						
				CL150 RF	-20 to 100	-29 to 38						
					-20 to 150	-29 to 66						
			NPT	-20 to 100	-29 to 38							
				-20 to 150	-29 to 66							
			Cast iron	CL125 FF	-20 to 100	-29 to 38						
					-20 to 150	-29 to 66						
NPT	-20 to 100	-29 to 38										
	-20 to 150	-29 to 66										
LS250 and LS254	20 to 60	1.37 to 4.13	Ductile iron	PN 16	-20 to 100	-29 to 38	232	16	232	16	232	16
					-20 to 150	-29 to 66						
				CL150 RF	-20 to 100	-29 to 38						
					-20 to 150	-29 to 66						
			Steel	PN 16	-20 to 100	-29 to 38						
					-20 to 150	-29 to 66						
				CL150 RF	-20 to 100	-29 to 38						
					-20 to 150	-29 to 66						
			NPT	-20 to 100	-29 to 38							
				-20 to 150	-29 to 66							
			Cast iron	CL125 FF	-20 to 100	-29 to 38						
					-20 to 150	-29 to 66						
NPT	-20 to 100	-29 to 38										
	-20 to 150	-29 to 66										

North America Only

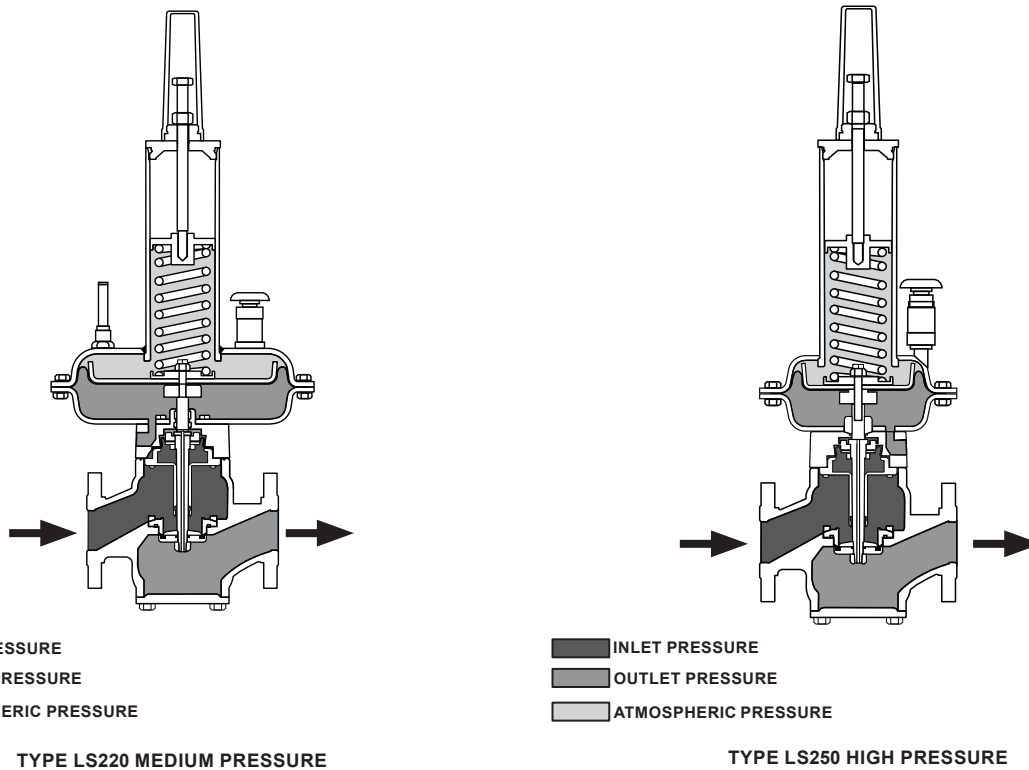

Figure 2. LS200 Series Regulator Operational Schematic

Table 6. Pressure Ranges and Body Pressure-Temperature Ratings With PED Certification

TYPE	OUTLET RANGE		BODY MATERIAL	END CONNECTION	TEMPERATURE RANGE		MAX OPERATING INLET		MAX BODY PRESSURE RATING		
	psig	bar			°F	°C	psig	bar	psig	bar	
LS220 and LS224	4.35 to 10	0.3 to 0.69	Ductile iron	PN 16	-4 to 100	-20 to 38	125	8.6	232	16	
					-4 to 140	-20 to 60					
			CL150 RF	-4 to 100	-20 to 38						
				-4 to 140	-20 to 60						
			Steel	PN 16	-4 to 100	-20 to 38					
					-4 to 140	-20 to 60					
	NPT	-4 to 100			-20 to 38						
	LS220 and LS224	10 to 21.7	0.69 to 1.5	Ductile iron	PN 16	-4 to 100	-20 to 38	232	16	232	16
						-4 to 140	-20 to 60				
CL150 RF				-4 to 100	-20 to 38						
				-4 to 140	-20 to 60						
Steel				PN 16	-4 to 100	-20 to 38					
					-4 to 140	-20 to 60					
		NPT	-4 to 100		-20 to 38						
LS250 and LS254		20 to 60	1.37 to 4.13	Ductile iron	PN 16	-4 to 100	-20 to 38	232	16	232	16
						-4 to 140	-20 to 60				
	CL150 RF			-4 to 100	-20 to 38						
				-4 to 140	-20 to 60						
	Steel			PN 16	-4 to 100	-20 to 38					
					-4 to 140	-20 to 60					
		NPT	-4 to 100		-20 to 38						

LS200 Series

Introduction

Description

The LS200 Series direct-operated gas regulators are primarily designed for low pressure natural gas distribution systems, industrial and commercial applications supplying gas to furnaces, burners, and other appliances. The LS200 balanced port design enables the regulator to provide accurate control of gas pressure for maximum combustion efficiency despite varying inlet pressure conditions. The single port construction provides bubble-tight shutoff. An external downstream control line is required for the operation of the regulator. Refer to Table 2 for outlet pressure ranges of each type. LS200 Series regulators are available in a 2 in. / DN 50 body size with either NPT or flanged end connections.

An optional restriction collar can be installed if wide-open capacity is too high for applications using a relief valve as overpressure protection. The collar reduces wide-open capacity to 40%, 60% or 78% of wide open capacity. 78% is sized for replacing the legacy Type 133HP 100% units without needing to resize the relief valve.

Principle of Operation

In the LS200 Series, downstream pressure is registered under the diaphragm via the external control line and is used as the operating medium. Increased demand lowers the downstream pressure and allows the spring to move the diaphragm and stem assembly down, opening the valve disk and supplying more gas to the downstream system. Decreased demand increases the downstream pressure and moves the diaphragm and stem assembly up, closing the valve disk and decreasing the gas supply to the downstream system.

Boosting System

The LS200 Series incorporates a balancing diaphragm and a boosting system. When the regulator is locked up, inlet pressure is registered on the top of the disk and on the bottom of the balancing diaphragm through space between the stem and cage. Also, downstream pressure is registered on the bottom of the disk and on the top of the balancing diaphragm through a passage in the stem.

When the trim is open, gas flows from the inlet over the edge of the disk to the outlet. Under the disk, there is little gas flow. The gas pressure is higher than it is in the flow path where gas velocity tends to lower the pressure. The higher pressure near the disk is registered on the top of the balancing diaphragm through the space between the stem and the cage.

This pressure registered on the top of the balancing diaphragm aids downward disk travel and compensates for spring and diaphragm effect. This improves regulator rangeability and performance

Installation

The regulator may be installed with actuator above or below the body but is normally installed with the actuator portion above the body portion. Flow through the body must be in the direction indicated by the flow direction arrow cast on the body portion. A downstream control line is required for operation of the regulator.

A remote vent line may be required for some installations. Vent openings must be protected against the entrance of rain, snow, insects, or any other foreign material that may plug the vent.

External dimensions are shown in Figure 3.

Integrated Slam-shut

The LS200 Series is offered with an integral slamshut device that will stop gas from flowing if an over pressure or under pressure condition occurs.

The slam-shut design is industry leading with only design allowing choice of which side of the body to install the slam-shut.

The slam-shut measuring element utilizes the VSX8 Series actuator (see VSX8 Series literature for more details and support). The VSX8 Series uses a positive latching mechanism instead of a ball bearing design. The Positive Latch Mechanism reduces false trips related to vibration or external factors. See Figure 3 for more information.

Overpressure Protection

As is the case with most regulators, the LS200 Series regulators have outlet pressure ratings that are lower than the inlet pressure ratings. Some type of Overpressure Protection is needed if the actual inlet pressure ever exceeds the outlet pressure rating.

Maximum inlet and outlet pressures for the LS200 are given in Table 3. All models must be protected against inlet pressure above the maximum emergency inlet pressure (refer to Table 3).

Capacity Data

Flow capacities for various inlet pressures and outlet pressure settings are shown in Tables 7 and 8. Capacities are in thousands of Nm³/hr and SCFH at 60°F and 14.7 psia and in thousands of Nm³/h at 0°C and 1.01325 bar of 0.6 specific gravity gas. To convert to equivalent capacities of other gases, multiply the SCFH values shown by the appropriate factor: air– 0.775; propane–0.628; butane–0.548; nitrogen–0.789. For gases of other specific gravities, multiply the given capacity by 0.775, and divide by the square root of the appropriate specific gravity. Then, if capacity is desired in Nm³/h at 0°C and 1.01325 bar, multiply SCFH by 0.0268.

Note

For optimum performance, select the lowest spring range that includes the desired outlet pressure setting. Capacity Data gathered using 4 in. / DN 100 outlet piping.

For restricted-capacity constructions, determine flow capacities for outlet pressure settings of 2 psig / 0.14 bar or less by multiplying the values from Tables 7 and 8 by 40%, 60% or 78% (depending upon which restriction collar is selected). If flow capacities for inlet pressures lower than those shown are required, contact your local Sales Office.

The representative regulating C_g of 2000 may be used for regulator sizing of full capacity constructions only if capacity table data is not available. The representative regulating C_g is an approximation only for pressure drops greater than 5 psi / 0.34 bar, because, at a given offset in controlled pressure, the regulating C_g varies with the spring being used with the pressure drop across the valve.

To determine capacity using the flow coefficient C₁, use the appropriate procedure below.

Critical Pressure Drops

For critical pressure drops (absolute outlet pressure equal to or less than one-half of absolute inlet pressure), use the following formula:

$$Q = (P_1)(C_g)(1.29)$$

Non-Critical Pressure Drops

For pressure drops lower than critical (absolute outlet pressure greater than one-half of absolute inlet pressure).

$$Q = \sqrt{\frac{520}{GT}} C_g P_1 \text{SIN} \left[\frac{3417}{C_1} \sqrt{\frac{\Delta P}{P_1}} \right] \text{DEG}$$

where,

- Q = gas flow rate, SCFH
- P₁ = absolute inlet pressure, psia (P₁ gauge + 14.7)
- C_g = regulating or wide-open gas sizing coefficient
- G = specific gravity of the gas
- T = absolute temperature of gas at inlet, °Rankine
- C₁ = flow coefficient
- ΔP = pressure drop across the regulator, psi

LS200 Series

Table 7. Full-Capacity Type LS220 with 2:1 Piping, 0.6 Specific Gravity Natural Gas

OUTLET PRESSURE SETTING		INLET PRESSURE		2-IN. / DN 50 BODY SIZE, 2.0 IN. / 51.3 mm ORIFICE SIZE							
				Droop From Setpoint							
				1% ABS		2% ABS		10% ABS		20% ABS	
psig	bar	psig	bar	SCFH	Nm ³ /hr	SCFH	Nm ³ /hr	SCFH	Nm ³ /hr	SCFH	Nm ³ /hr
5	0.3	10	0.7	8710	247	12500	354	43793	1240	52782	1495
		20	1.4	17981	509	23333	661	76187	2158	78460	2222
		40	2.8	82341	2332	99325	2813	106583	3018	116580	3302
		60	4.1	160502	4545	163943	4643	169001	4786	175868	4981
		80	5.5	148524	4206	212521	6019	220382	6241	226357	6410
		100	6.9					271356	7685	275384	7799
10	0.7	25	1.7					79675	2256	98543	2791
		30	2.1					95578	2707	113369	3211
		40	2.8					128326	3634	136922	3878
		60	4.1					164764	4666	175813	4979
		80	5.5					206072	5836	213117	6035
		100	6.9					227091	6431	248661	7042
		125	8.6					258352	7317	291690	8261
		150	10.3					347977	9855	378982	10733
		175	12.1					412382	11679	412382	11679
		200	13.8					419140	11870	419140	11870
15	1.0	25	1.7					63320	1793	91978	2605
		30	2.1					75870	2149	107200	3036
		40	2.8					109237	3094	135242	3830
		60	4.1					157822	4470	168784	4780
		80	5.5					176053	4986	203002	5749
		100	6.9					228210	6463	253770	7187
		125	8.6					242342	6863	281076	7960
		150	10.3					344421	9754	374208	10598
		175	12.1					403178	11418	435217	12325
		200	13.8					487168	13797	487168	13797
20	1.4	25	1.7					57105	1617	83081	2353
		30	2.1					71741	2032	103356	2927
		40	2.8					92019	2606	137065	3882
		60	4.1					146788	4157	189690	5372
		80	5.5					198183	5613	242433	6866
		100	6.9					242207	6859	291671	8260
		125	8.6					296678	8402	328691	9309
		150	10.3					357304	10119	402787	11407
		175	12.1					419415	11878	480841	13617
		200	13.8					482888	13675	540298	15301
		250	17.2					574641	16274	574641	16274
		285	19.7					580490	16439	580490	16439

North America Only

Table 8. Full-Capacity Type LS250 with 2:1 Piping, 0.6 Specific Gravity Natural Gas

OUTLET PRESSURE SETTING		INLET PRESSURE		2 IN. / DN 50 BODY SIZE, 2.0 IN. / 51.3 mm ORIFICE SIZE			
				Droop From Setpoint			
				10% ABS		20% ABS	
psig	bar	psig	bar	SCFH	Nm ³ /hr	SCFH	Nm ³ /hr
20	1.4	25	1.7	42969	1217	72402.9	2050
		30	2.1	55879	1582	96957	2746
		40	2.8	71664	2030	124914	3538
		60	4.1	100779	2854	175967	4983
		80	5.5	138015	3909	210399	5958
		100	6.9	168795	4780	241432	6837
		125	8.6	201671	5711	285610	8088
		150	10.3	242797	6876	329767	9339
		175	12.1	259684	7354	349631	9902
		200	13.8	296426	8395	379383	10744
		250	17.2	344604	9759	458721	12991
25	1.7	30	2.1	54032	1530	83869	2375
		40	2.8	78272	2217	122256	3462
		60	4.1	115940	3283	175671	4975
		80	5.5	147934	4189	218539	6189
		100	6.9	184843	5235	250347	7090
		125	8.6	219609	6219	272706	7723
		150	10.3	253652	7183	310506	8794
		175	12.1	285207	8077	357683	10130
		200	13.8	303069	8583	414319	11734
		250	17.2	369082	10452	463999	13140
		285	19.7	412132	11672	498617	14121
30	2.1	40	2.8	58971	1670	104333	2955
		60	4.1	97911	2773	162372	4598
		80	5.5	132589	3755	209198	5924
		100	6.9	158840	4498	245500	6953
		125	8.6	196339	5560	272671	7722
		150	10.3	229608	6503	297992	8439
		175	12.1	258684	7326	336938	9542
		200	13.8	288351	8166	377789	10699
		250	17.2	343927	9740	425235	12043
40	2.8	60	4.1	116231	3292	167861	4754
		80	5.5	149226	4226	210237	5954
		100	6.9	183998	5211	262117	7423
		125	8.6	222341	6297	317328	8987
		150	10.3	255638	7240	387193	10965
		175	12.1	289429	8197	441489	12503
		200	13.8	323134	9151	493538	13977
		250	17.2	385536	10918	586912	16621
		285	19.7	438793	12427	623680	17663
50	3.4	60	4.1	84226	2385	152954.1	4332
		80	5.5	134742	3816	210297.3	5956
		100	6.9	171986	4871	264217.3	7483
		125	8.6	205660	5824	319275.5	9042
		150	10.3	242662	6872	372500.8	10549
		175	12.1	276234	7823	422908.9	11977
		200	13.8	305373	8648	457419.6	12954
		250	17.2	368722	10442	546566.5	15479
		285	19.7	417982	11837	592009.6	16766
60	4.1	70	4.8	111857	3168	170493.5	4828
		80	5.5	138535	3923	195192.6	5528
		100	6.9	178838	5065	246702.4	6987
		125	8.6	222557	6303	297393.7	8422
		150	10.3	262445	7432	353264.9	10004
		175	12.1	306367	8676	370825.1	10502
		200	13.8	336440	9528	411064.7	11641
		250	17.2	407264	11534	598146.7	16940
285	19.7	446768	12652	672443.1	19044		

LS200 Series

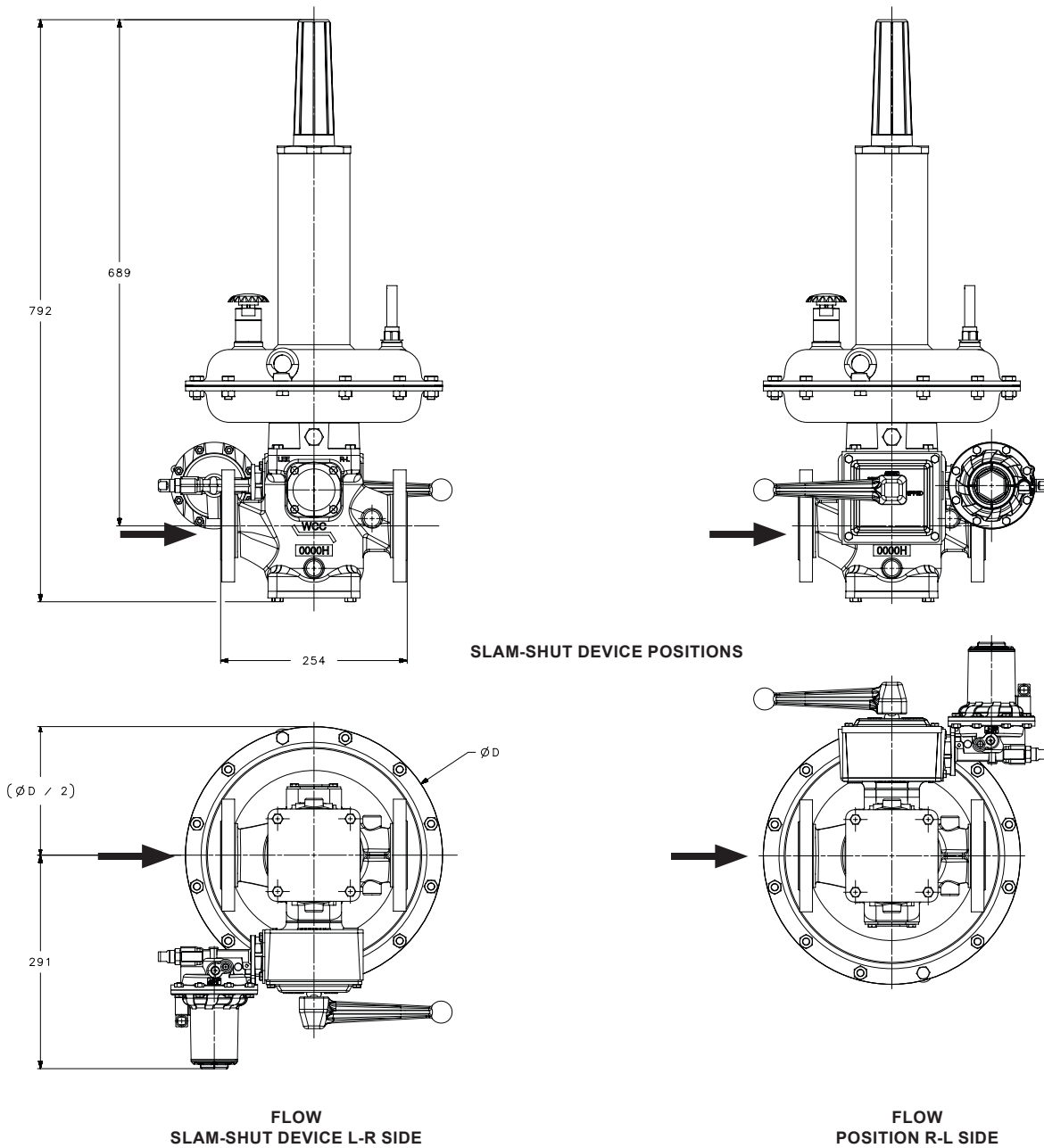

North America Only

TYPE	DIAMETER	
	In.	mm
LS200	18.7	475
LS220	13.8	350
LS250	10	255

Figure 3. LS200 Series with Slam-Shut Device Assembly Positions and Dimensions

Ordering Information

Use the Specifications section on page 2 and carefully review the description to the right of each specification. Use this information to complete the Ordering Guide

on the following page. Specify the desired selection wherever there is a choice to be made. Then send the Ordering Guide to your local Sales Office.

Ordering Guide

Actuator (Select One)

- Type LS220
- Type LS250

Body Material and End Connection Style (Select One)

Ductile Iron

- PN16
- CL150 RF
- PN16 with expanded outlet
- CL150 RF with expanded outlet

Steel

- NPT
- PN16
- CL150 RF
- PN16 with expanded outlet
- CL150 RF with expanded outlet

Outlet Pressure Range (Select One)

Type LS220

- 4.35 to 5.1 psig / 0.30 to 0.35 bar, Light Green
- 4.35 to 10.6 psig / 0.3 to 0.73 bar, Pink
- 4.8 to 15.7 psig / 0.33 to 1.08 bar, Dark Blue
- 8.3 to 21.75 psig / 0.57 to 1.5 bar, Orange

Type LS250

- 20 to 30.3 psig / 1.38 to 2.09 bar, Pink
- 20 to 44.8 psig / 1.38 to 3.09 bar, Dark Blue
- 25 to 60 psig / 1.72 to 4.14 bar, Orange

Trim, Percent of Full Capacity (Select One)

- 100% (standard)
- 78%
- 60%
- 40%

Elastomers

- Nitrile (NBR) (standard)

Slam-Shut Position (refer to Figure 3) (Select One)

- L-R
- R-L
- L-R with Field Conversion Option
- R-L with Field Conversion Option

LS200 Series

Regulators Quick Order Guide	
***	Readily Available for Shipment
**	Allow Additional Time for Shipment
*	Special Order, Constructed from Non-Stocked Parts. Consult your local Sales Office for Availability.
Availability of the product being ordered is determined by the component with the longest shipping time for the requested construction.	

Specification Worksheet

Application:
 Specific Use _____
 Line Size _____
 Fluid Type _____
 Specific Gravity _____
 Temperature _____
 Does the Application Require Overpressure Protection?
 Yes No

Pressure:
 Maximum Inlet Pressure (P_{1max}) _____
 Minimum Inlet Pressure (P_{1min}) _____
 Downstream Pressure Setting(s) (P_2) _____
 Set Pressure _____
 Maximum Flow (Q_{max}) _____

Accuracy Requirements:
 Less Than or Equal To:
 5% 10% 20% 40%

Construction Material Requirements (if known):

North America Only

 Webadmin.Regulators@emerson.com

 Facebook.com/EmersonAutomationSolutions

 Fisher.com

 LinkedIn.com/company/emerson-automation-solutions

 Twitter.com/emr_automation

Emerson Automation Solutions

Americas

McKinney, Texas 75070 USA
 T +1 800 558 5853
 +1 972 548 3574

Europe

Bologna 40013, Italy
 T +39 051 419 0611

Asia Pacific

Singapore 128461, Singapore
 T +65 6777 8211

Middle East and Africa

Dubai, United Arab Emirates
 T +971 4 811 8100

D104646X012 © 2023 Emerson Process Management Regulator Technologies, Inc. All rights reserved. 01/23.
 The Emerson logo is a trademark and service mark of Emerson Electric Co. All other marks are the property of their prospective owners. Fisher™ is a mark owned by Fisher Controls International LLC, a business of Emerson Automation Solutions.

The contents of this publication are presented for information purposes only, and while effort has been made to ensure their accuracy, they are not to be construed as warranties or guarantees, express or implied, regarding the products or services described herein or their use or applicability. All sales are governed by our terms and conditions, which are available on request. We reserve the right to modify or improve the designs or specifications of our products at any time without notice.

Emerson Process Management Regulator Technologies, Inc. does not assume responsibility for the selection, use or maintenance of any product. Responsibility for proper selection, use and maintenance of any Emerson Process Management Regulator Technologies, Inc. product remains solely with the purchaser.

