

USB programmable! Free software at
www.defineinstruments.com/toolbox



TM-4DPI Common Specifications

Configuration 4-wire

Voltage output 0–10V DC or ± 10 V DC

Current output 4–20mA, 0–20mA, 20–4mA or 20–0mA. 20mA max output drive (650 Ω max load at 13V DC).

Power supply 21–300V DC or 85–265V AC

EMC compliance Emissions (EN 61326), Immunity (EN 61326), Safety (EN 61010-1)

Accurate to $<\pm 0.03\%$ FSO typical

Ambient drift $<\pm 0.003\%/^{\circ}\text{C}$ FSO typical

Noise immunity 125dB CMRR average (2.0kV DC limit)

R.F. immunity $<1\%$ effect FSO typical

Operating humidity 5–85%RH max (non-condensing)

Operating temperature -20 to 85 $^{\circ}\text{C}$ (-4 to 185 $^{\circ}\text{F}$)

Storage temperature -20 to 100 $^{\circ}\text{C}$ (-4 to 212 $^{\circ}\text{F}$)

Isolation test voltages between input/output: 3750V AC for 1min

Response time 400msec typical (10–90% 300msec typical)

Mounting 35mm symmetrical DIN rail

Dimensions (H x W x D) 79 x 30 x 68mm (3.11 x 1.18 x 2.68")



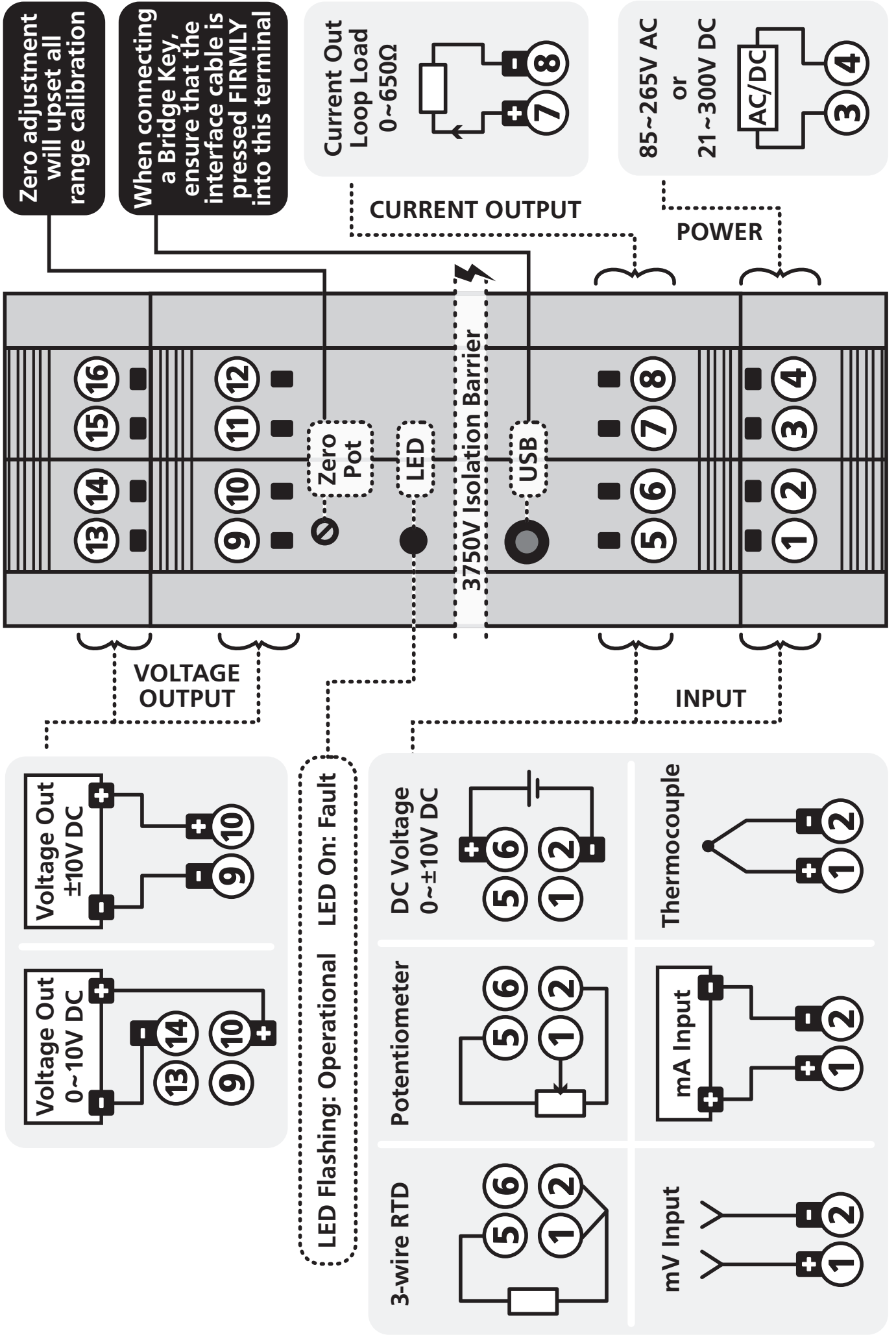

Voltage Input Specifications

USB programmable zero 0–±99% of the span

USB programmable span 100mV to ±10V DC (bipolar)

Input resistance 300kΩ min

Maximum over-range 60V DC continuous

Linearity and repeatability <±0.02% FSO typical

Current Input Specifications

USB programmable zero 0–±99% of the span

Field programmable span 1μA–24mA DC

Input resistance 10Ω

Maximum over-range 50mA DC continuous

Linearity and repeatability <±0.02% FSO typical

Thermocouple Input Specifications

Thermocouple types B, E, J, K, N, R, S, T

USB programmable zero 0–±99% of the span

Field programmable span Refer to ordering information for min/max ranges for each type

Input impedance 1MΩ min

Thermocouple lead resistance 100Ω max

Cold junction comp. -20 to 90°C (-4 to 194°F)

Accuracy E, J, K, N, T: < ±1°C. B, R, S: < ±2°C.

Temperature drift E, J, K, N, T: < ±0.05°C. B, R, S: < ±0.2°C.

Sensor break output drive Function high upscale/low downscale

CJC error < ±1°C

RTD Input Specifications

RTD input Pt100 or Pt1000 DIN 3-wire type (2-wire can be used with offset calibration)

Sensor current 0.15mA nominal

Lead wire resistance Pt100: 10Ω/wire max. Pt1000: 5Ω/wire max.
0.02% FSO offset error per Ω of lead resistance.

USB programmable zero 0–±99% of the span

USB programmable span -200 to 850°C (-328 to 1562°F)

Sensor break output drive Function high upscale/low downscale

Linearity (PT100) 0.02% FSO for span inputs ≤200°C (392°F)
0.1% FSO for span inputs ≤850°C (1562°F)

Linearity (PT1000) 0.02% FSO for span inputs ≤200°C (392°F)
0.2% FSO for span inputs ≤520°C (968°F)

Other available RTD types JIS, PT100/1000, Pt392, CN10

Potentiometer Input Specifications

Potentiometer input 3-wire potentiometer

Excitation voltage 1.2V DC



Potentiometer resistance 0–2KΩ low pot, 0–1MΩ high pot



Field programmable zero 0–90% of the span

Field programmable span 0.1–100%

Linearity and repeatability <±0.02% FSO typical

Define Instruments

New Zealand (Head Office)  +64 (9) 835 1550  defineinstruments.co.nz

United States (Dallas, TX)  (214) 926 4950  defineinstruments.com

South Africa (JHB)  087 945 2700  defineinstruments.co.za