

# TFB24-SR Damper Actuator Technical Data Sheet

## Modulating, Spring Return, AC 24 V/DC, for DC 2...10 V or 4...20 mA Control Signal



Technical Data	
Power Supply	24 VAC, ±20%, 50/60 Hz, 24 VDC, ±10%
Power consumption in operation	2 W
Power consumption in rest position	1 W
Transformer sizing	4 VA (class 2 power source)
Shaft Diameter	1/4...1/2" round, centers on 1/2"
Electrical Connection	18 GA plenum cable, 3 ft [1 m], with 1/2" conduit connector
Overload Protection	electronic throughout 0...95° rotation
Electrical Protection	actuators are double insulated
Operating Range	2...10 V, 4...20 mA w/ ZG-R01 (500 Ω, 1/4 W resistor)
Input Impedance	100 kΩ for 2...10 V (0.1 mA), 500 Ω for 4...20 mA
Position Feedback	2...10 V, Max. 0.5 mA
Angle of rotation	Max. 95°, adjustable with mechanical stop
Torque motor	22 in-lb [2.5 Nm]
Direction of motion motor	selectable with switch 0/1
Direction of motion fail-safe	reversible with cw/ccw mounting
Position indication	Mechanical
Running Time (Motor)	95 s constant, independent of load
Running time fail-safe	<25 s @ -4...122°F [-20...50°C], <60 s @ -22°F [-30°C]
Ambient humidity	max. 95% r.H., non-condensing
Ambient temperature	-22...122°F [-30...50°C]
Storage temperature	-40...176°F [-40...80°C]
Degree of Protection	IP42, NEMA 2, UL Enclosure Type 2
Housing material	UL94-5VA
Agency Listing	cULus acc. to UL60730-1A/-2-14, CAN/CSA E60730-1:02, CE acc. to 2014/30/EU
Noise level, motor	35 dB(A)
Noise level, fail-safe	62 dB(A)
Servicing	maintenance-free
Quality Standard	ISO 9001
Weight	1.6 lb [0.71 kg]

†Rated Impulse Voltage 800V, Type of action 1.AA, Control Pollution Degree 3

**Torque min. 22 in-lb, for control of air dampers.**

### Application

For fail-safe, modulating control of dampers in HVAC systems. Actuator sizing should be done in accordance with the damper manufacturer's specifications. The actuator is mounted directly to a damper shaft from 1/4" up to 1/2" in diameter by means of its universal clamp, 1/2" shaft centered at delivery. A crank arm and several mounting brackets are available for applications where the actuator cannot be direct coupled to the damper shaft. The actuator operates in response to a 2 to 10 VDC, or with the addition of a 500Ω resistor, a 4 to 20 mA control input from an electronic controller or positioner. A 2 to 10 VDC feedback signal is provided for position indication.

### Operation

The TF series actuators provide true spring return operation for reliable fail-safe application and positive close-off on air tight dampers. The spring return system provides consistent torque to the damper with, and without, power applied to the actuator. The TF series provides 95° of rotation and is provided with a graduated position indicator showing 0 to 95°. The TF uses a brushless DC motor which is controlled by an Application Specific Integrated Circuit (ASIC) and a microprocessor. The microprocessor provides the intelligence to the ASIC to provide a constant rotation rate and to know the actuator's exact fail-safe position. The ASIC monitors and controls the brushless DC motor's rotation and provides a digital rotation sensing function to prevent damage to the actuator in a stall condition. The actuator may be stalled anywhere in its normal rotation without the need of mechanical end switches. Power consumption is reduced in holding mode.

**Safety Note:** Screw a conduit fitting into the actuator's bushing. Jacket the actuator's input and output wiring with suitable flexible conduit. Properly terminate the conduit in a suitable junction box.

### Dimensions (Inches[mm])

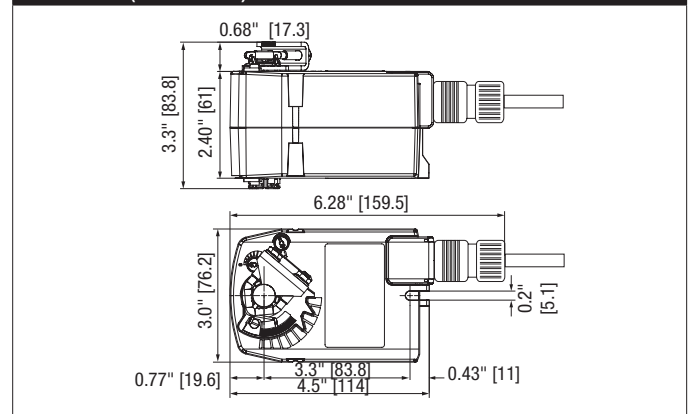

Accessories	
AV6-20	Shaft extension
IND-TF	TF position indicator.
K8 US	Standard TFB(X) clamp (1/4" to 1/2").
KG10A	Ball joint
KG8	Ball joint
KH8	Damper crank arm
KH-TF US	TFB(X) crankarm with 5/16" slot.
KH-TF-1 US	TFB(X) crankarm with 1/4" slot.
SB-TF	Screw fastening kit
SH10	Push rod for KG10A ball joint (36" L, 3/8" diameter).
SH8	Push rod for KG6 & KG8 ball joints (36" L, 5/16" diameter).
TF-P	Anti-rotation bracket TF/NKQ/AM/NM/LM.
TOOL-06	8 mm and 10 mm wrench.
ZDB-TF	Angle of rotation limiter
ZG-113	TFB(X) right angle bracket 4-1/2x5-1/2x2-1/2" (HxWxD).
ZG-DC1	Damper clip for damper blade, 3.5" width.
ZG-DC2	Damper clip for damper blade, 6" width.
ZG-LMSA-1	Shaft extension for 3/8" diameter shafts (4" L).
ZG-LMSA-1/2-5	Shaft extension for 1/2" diameter shafts (5" L).
ZG-TF112	TFB(X) crankarm adaptor kit (includes ZG-113).
ZG-TF2	TFB(X) crankarm adaptor kit (T bracket included).
ZS-100	Weather shield - galvaneal 13x8x6" (LxWxD).
ZS-101	Base plate for ZS-100.
ZS-150	Weather shield - PC w/ foam seal 16x8-3/8x4" (LxWxD).
IRM-100	Input rescaling module for modulating actuators.
P475	Shaft mount, non-Mercury aux. switch for 1/2" dia. shafts.
P475-1	Shaft mount, non-Mercury aux. switch for 1" dia. shafts.
PS-100	Low voltage and control signal simulator.
PTA-250	Pulse width modulation interface for modulating actuators.
SGA24	Positioners suitable for use with the modulating damper actuators LM..A-SR, NM..A-SR, SM..A-SR and GM..A-SR
SGF24	Positioners suitable for use with the modulating damper actuators LM..A-SR, NM..A-SR, SM..A-SR and GM..A-SR
TF-CC US	Cable conduit connector, 1/2".
ZG-R01	4 to 20 mA adaptor, 500Ω, 1/4 W resistor w 6" pigtail wires.
ZG-R02	50% voltage divider kit (resistors with wires).
ZG-SGF	Mounting plate for SGF.
ZG-X40	120 to 24 VAC, 40 VA transformer.

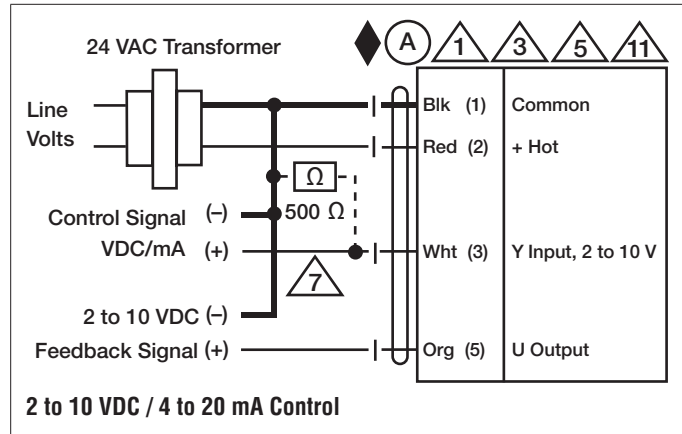

### Typical Specification

Spring return control damper actuators shall be direct coupled type which require no crank arm and linkage and be capable of direct mounting to a shaft up to a 1/2" diameter and center on a 1/2" shaft. The actuator must provide modulating damper control in response to a 2 to 10 VDC or, with the addition of a 500Ω resistor, a 4 to 20 mA control input from an electronic controller or positioner. The actuator must be designed so that they may be used for either clockwise or counter clockwise fail-safe operation. Actuators shall use a brushless DC motor controlled by a microprocessor and be protected from overload at all angles of rotation. Run time shall be constant, and independent of torque. A 2 to 10 VDC feedback signal shall be provided for position feedback. If required, one SPDT auxiliary switch shall be provided having the capability of being adjustable. Actuators with auxiliary switch must be constructed to meet the requirements for Double Insulation so an electrical ground is not required to meet agency listings. Actuators shall be cULus listed, have a 5 year warranty, and be manufactured under ISO 9001 International Quality Control Standards. Actuators shall be as manufactured by Belimo.

# TFB24-SR Damper Actuator Technical Data Sheet

Modulating, Spring Return, AC 24 V/DC, for DC 2...10 V or 4...20 mA Control Signal

## Wiring Diagrams



### **WARNING! LIVE ELECTRICAL COMPONENTS!**

During installation, testing, servicing and troubleshooting of this product, it may be necessary to work with live electrical components. Have a qualified licensed electrician or other individual who has been properly trained in handling live electrical components perform these tasks. Failure to follow all electrical safety precautions when exposed to live electrical components could result in death or serious injury.



Meets cULus requirements without the need of an electrical ground connection.



Apply only AC line voltage or only UL-Class 2 voltage to the terminals of auxiliary switches. Mixed or combined operation of line voltage/safety extra low voltage is not allowed.



Actuators with appliance cables are numbered.



Provide overload protection and disconnect as required.



Actuators may also be powered by 24 VDC.



Only connect common to negative (-) leg of control circuits.



A 500  $\Omega$  resistor (ZG-R01) converts the 4 to 20 mA control signal to 2 to 10 VDC.



Actuators may be connected in parallel if not mechanically linked. Power consumption and input impedance must be observed.



One built-in auxiliary switch (1x SPDT), for end position indication, interlock control, fan startup, etc.