



Actuators for air and gas dampers SQM9...

Electromotoric actuators

- **Torques** up to 60 Nm
- **Running times ¹⁾** 30...120 s

¹⁾ Predefined by the basic unit (LMV5...)

The SQM9... and this Data Sheet are intended for use by OEMs which integrate the actuators in their products!

Use

The actuators SQM9 are suited for driving oil pressure controllers, butterfly valves, dampers or for use on other applications that require rotary motion. Areas of application are oil and gas burners of medium to larger capacity, as well as thermal process plants.

The actuators are used primarily for the load-dependent control of the gas flow, oil volume and combustion air volume in connection with the electronic ratio control LMV5.

Supplementary documentation

Product type	Type of documentation	Documentation number
LMV5...	Basic documentation	P7550
AZL5...	User documentation	A7550

Warning notes



To avoid injury to persons, damage to property or the environment, the following warning notes must be observed!

Not permitted: Interventions or modifications.

To commission the actuator, the housing cover may be opened!

- Read the documentation on the actuators carefully and fully. If not observed, dangerous situations can occur
- The user must ensure that the actuators meet the requirements of the relevant application standards
- Safety-related applications are only available with Siemens burner controls
- All product-related activities (mounting, settings and maintenance) must be performed by qualified and authorized personnel



Attention!

- Risk of electric shock hazard – to disconnect the equipment from the power, it may be necessary to open more than one switch. Before performing maintenance work, the equipment must be disconnected from power.
 - The electrical connection between the conduit fittings is not made automatically. It must be established on installation site.
-
- To ensure protection against electric shock, the connection terminals must have adequate touch protection. Make certain that noninsulated connections or wires cannot be touched
 - Whenever work has been carried out (mounting, installation, service work, etc.), check to ensure that wiring is in an orderly state
 - Fall or shock can adversely affect the safety functions. Such actuators must not be put into operation, even if they do not exhibit any damage
 - Static charges must be avoided since they can damage the actuator's electronic components when touched.
Recommendation: Use ESD equipment
 - During operation, the actuator's surface can reach high temperatures.
Recommendation: After operation, allow the actuator to cool down. If not observed, there is a risk of burning

Notes on use in North America

Only flexible conduits with relevant accessories may be used.

Mounting notes



Note!

Also not the enclosed Mounting Instruction 74 319 0842 0 (M7818)!

- Ensure that the relevant national safety regulations and notes on standards are complied with
- In geographical areas where DIN regulations apply, the mounting and installation requirements of VDE must be satisfied, especially DIN/VDE 0100, 0550 and DIN/VDE 0722
- The actuator must be disconnected from power before its cover is removed. This allows the actuator to cool down. During operation, the actuator's internal components get hot, especially the motor, which may reach 100 °C. If not observed, there is a risk of burning

Positive connection



Caution!

The drive shaft connection must be form-fitted using a key type A as per DIN 6885.

To avoid inadmissible loads and torques due to mechanical overload, appropriate measures must be taken at the mechanical coupling.

Example: Use metal bellows coupling without mechanical play.

Cable and cable shielding

Use of the specified cable is mandatory (see LMV5... Basic Documentation P7550). The cable's shield must be connected to the printed circuit board using the tab provided.



Caution!

Ensure that the actuator's housing is connected to functional earth (FE) of the system. If necessary, remove isolating layers of paint from the fixing points on the burner's casing or run separate earth wires. For detailed information, see *Installation Instructions for the LMV5... system (J7550.1)*.

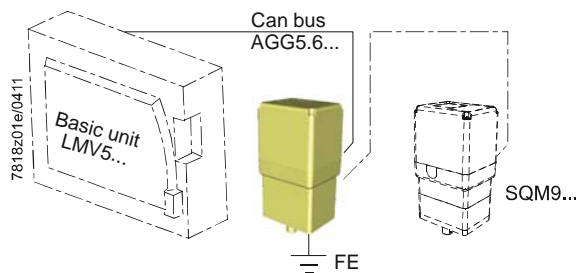

Working range of actuator

The working range is given on the type field and must be observed when mounting the actuator. To ensure the actuator is accurately located on the burner, a positioning pin of 6 mm diameter must be fitted on the mounting surface.

IP66 / NEMA 4

To ensure **degree of protection IP66/NEMA 4**, suitable M20 glands must be fitted in the actuator's M20 openings. The M20 glands used must provide cable strain relief.

Drive shaft

The actuator comes with the key fitted. During transport, the key is held in the groove by means of an O-ring. Remove the O-ring before mounting the actuator.

Installation notes

- Ensure that the electrical wiring is in compliance with national and local safety regulation
- Make certain that strain relief of the connected cables conforms to the relevant standards (e.g. as per DIN EN 60730 and DIN EN 60335)
- Ensure that spliced wires cannot get into contact with neighboring terminals. Use adequate ferrules
- Unused terminals of the actuator must be covered by dummy plugs
- The connection between the actuator drive shaft and the relevant controlling element must be form-fitted.
- The holding torque is reduced when the actuator is disconnected from power

Housing cover



Caution!

The housing cover may only be removed for short periods of time for wiring or when making the addressing. It must be made certain that dust or dirt does not get inside the actuator while such work is carried out. If the housing cover is removed and fitted again, power must be turned off to avoid short-circuits caused by conducting housing components.

ESD



Caution!

The actuator contains a printed circuit board with ESD-sensitive components. The top side of the board carries a cover which affords protection against direct contact. This protective cover must not be removed! The underside of the board must not be touched.

Addressing

Addressing (assignment of functions) defines whether the actuator shall operate as a ...

- fuel actuator,
- air damper actuator, or
- auxiliary actuator,

and is made with the AZL5... display and operating unit and the addressing button under the actuator's housing cover (see LMV5... Basic Documentation P7550). The correct assignment of actuator functions can be checked with the help of flashing LEDs.

Cable length Topology

For the maximum permissible cable length, see LMV5... Basic Documentation P7550. Cabling must be strictly serial (**no branching permitted!**).

Standards and certificates



Note!
Only in conjunction with the basic unit LMV5 (see Basic Documentation P7550).



EAC Conformity mark (Eurasian Conformity mark)



ISO 9001:2008
ISO 14001:2004
OHSAS 18001:2007



China RoHS
Hazardous substances table:
<http://www.siemens.com/download?A6V10883536>

Lifetime

The actuator has a designed lifetime* of 250,000 start cycles (OFF ⇒ ON ⇒ OFF) under load with the rated torque in the entire rotation angle range, which under normal operating conditions in heating mode corresponds to approx. 10 years of service (starting from the production date given on the type field). This is based on the endurance tests specified in the standard EN 298.

A summary of the conditions has been published by the European Control Manufacturers Association (Afecor) (www.afecor.org).

The lifetime is based on use of the actuator according to the manufacturer's data sheet. After reaching the designed lifetime in terms of the number of burner startup cycles, or after the corresponding usage time, the actuator is to be replaced by authorized personnel.

* The designed lifetime is not the warranty time specified in the Terms of Delivery.

Service notes

Replacement

When replacing an actuator, the following points must be checked and corrected, if necessary:

- Addressing (assignment of functions)
- Bus termination
- Adjustment of curvepoints of electronic fuel-air ratio control (e.g. with the LMV5...)



Caution!
Before performing maintenance work, the actuator must be disconnected from power.

Disposal notes



The actuator contains electrical and electronic components and must not be disposed of together with domestic waste.
Local and currently valid legislation must be observed.

Mechanical design

Housing	<ul style="list-style-type: none">• Housing sections are made of die-cast aluminum and die-cast zinc• The housing is powder-coated (RAL 7032)
Drive motor	Stepper motor
Adjustment of switching points / position indication	In connection with the basic unit (e.g. LMV5...): Via the AZL5...display and operating unit (see LMV5... Basic Documentation P7550).
Electrical connections	<ul style="list-style-type: none">• RAST3.5 connectors with screw clamps (supplied with the AGG5.720/AGG5.721)• Wiring via basic unit• Easy insertion of cables through large openings in the housing
Gear train	Spur gears made of steel with only little backlash and permanent lubrication.
Drive shaft	<ul style="list-style-type: none">• Alloyed steel, hardened, ready fitted to the front of the gear train• The torque is transferred to the controlling element via a form-fitted key type A conforming to DIN 6885• The actuator comes with the key fitted• During transport, the key is held in the groove by means of an O-ring• The O-ring must be removed prior to mounting

The actuator is supplied with the drive shaft in the following position:

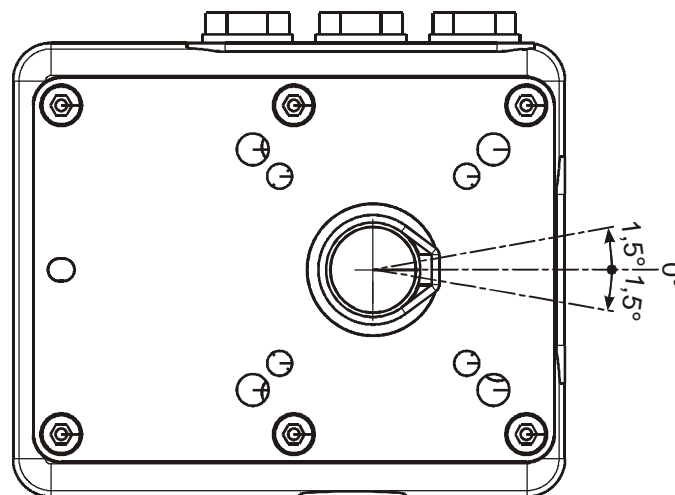

7818z02/0411

Mechanical design (cont'd)

Mounting and fixing

- The actuator is to be mounted from the side of the controlling element, using the 4 threaded holes M10 or M8 (see illustration)
- For tightening torques, see *Technical data*

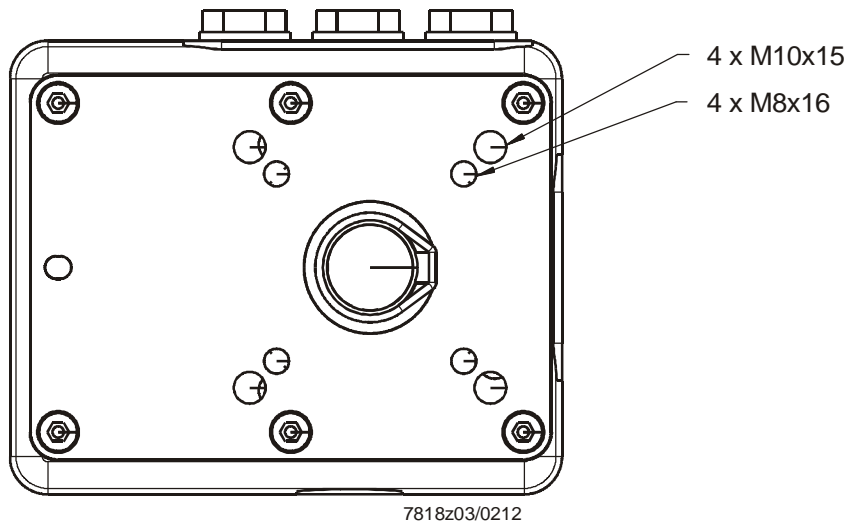

Type summary (other types on request)

When ordering, please give product no. of actuator according to *Type summary* and product nos. of accessories according to *Accessories*.

Article no.	Product no.	Running time for 90° (min.)	Nominal output torque (max.)	Holding torque 1) (max.)	Radial force perpendicular to the drive shaft (max.)	Axial force in the direction of the drive shaft (max.)
		s	Nm	Nm	N	N
BPZ:SQM91.391A9	SQM91.391A9	30	60	60	1300	1000

1) Power applied

Accessories

Accessories must be ordered as separate items.



CAN bus connecting cable

AGG5.641

- Between LMV5... and actuator or between actuators
- Shielded 5-core cable
- Cable length 100 m, 8 mm dia.
- Power supply 2 x 1.3 mm², 1 x 0.56 mm²
- Data line 2 x 0.22 mm²
- Double shielding
- See LMV5... Basic Documentation (P7550)



CAN bus connecting cable

AGG5.631

- Shielded 5-core cable, 100 m
- See LMV5... Basic Documentation (P7550)

Specified connecting cables are mandatory!

Connector set

AGG5.720

Standard connector set LMV5 for gas applications / oil applications with up to 3 actuators

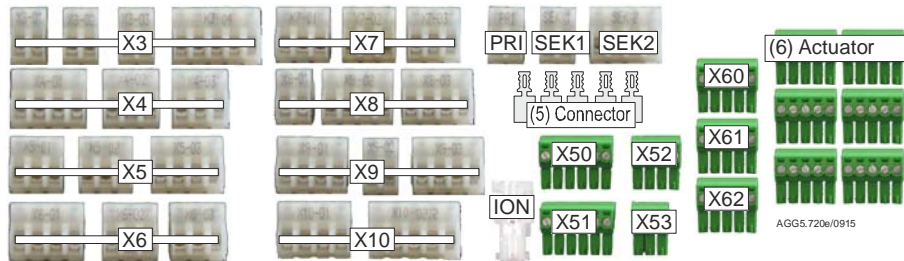

Connector set

AGG5.721

Extension connector set LMV5 (complementing AGG5.720, all connector versions are covered)



Transformer
AGG5.2...



Flame detector
QRB...



- Variable speed drive (VSD)
- Fuel meter



(2) Actuator
Actuator
SQM45...
SQM48...

Example Single connectors

AGG9.853



- Connector type RAST3.5
- 5-pole
- Packing unit 200 in total

Technical data

General unit data	Operating voltage	AC 2 x 12 V via separate transformer, see LMV5... Basic Documentation P7550!
	Drive motor	2-phase stepper motor
	Power consumption	Approx. 40 VA at rated mains voltage
	On time	50% at a maximum operating time of 90 s without interruption
	Angular adjustment	Max. 0...90°
	Mounting position	Optional
	Degree of protection	IP66 as per EN 60529, provided adequate cable entries are used North America: NEMA4
	Safety class	The actuator is designed for operation in environments of safety class III (as per DIN EN 60730-1)
	External overload fuse	Max. 4 AT (slow) to DIN EN 60127/2-5
	Cable entry	Cable glands 3 x M20, adapter for ½" NPT protection well thread (packaged with the actuator)
	Electrical connections	RAST3.5 connectors with screw clamps (for details, see LMV5... basic unit)
	Ferrules	Must match the dia. of the stranded wire
	Direction of action	Selectable on the basic unit
	Direction of rotation (when facing the drive shaft)	
	- Standard	Counterclockwise
	- Reverse	Clockwise
	Nominal output torque and holding torque	Refer to <i>Type summary</i>
	Running time	See <i>Type summary</i> (selectable on the basic unit)
	Life expectancy	Cycles (CLOSE ⇒ OPEN ⇒ CLOSE) at rated torque: typically 250,000
	Reproducibility of actuator positions across the usable angular range of 0...90°	±0.8° (typically, when used with the basic unit LMV5...)
	Drive shaft	Supplied as standard (not replaceable)
	Weight	Approx. 7.2 kg
	Tightening torques	
	- Cover screws	1 Nm
	- Fixing screws for the actuator	
	M10	26 Nm
	M8	16 Nm
	Temperature of the mounting surface	Max. 60 °C
	Lifetime	250,000 start cycles (OFF ⇒ ON ⇒ OFF) under load with the rated torque in the entire rotation angle range. 2,000,000 control cycles under load with 75% of rated torque in rotation angle range of 10°

Technical data (cont'd)

Environmental conditions

Storage	IEC 60721-3-1
Climatic conditions	Class 1K3
Mechanical conditions	Class 1M2
Temperature range	-20...60 °C
Humidity	<95% r.h.
Transport	IEC 60721-3-2
Climatic conditions	Class 2K2
Mechanical conditions	Class 2M2
Temperature range	-20...70 °C
Humidity	<95% r.h.
Operation	IEC 60721-3-3
Climatic conditions	Class 3K3
Mechanical conditions	Class 3M3
Temperature range	-20...+60 °C
Humidity	<95% r.h.
Installation altitude	Max. 2,000 m above sea level



Attention!

Condensation, formation of ice and ingress of water are not permitted. If this is not observed, there is a risk of loss of safety functions

Function

The actuators are of rugged design and have a gear train with only little backlash. Control and position feedback take place via a bus system (CAN). The bus cable is also used for powering the actuators.

The actuators are driven by stepper motors and can be positioned with a resolution of 0.1°.

The characteristics and settings (running time, direction of rotation, limit positions) of the actuators are determined by the controlling basic unit (for details, see LMV5... Basic Documentation P7550).

The running times of the associated controlling elements are varied by the basic unit (LMV5...) depending on the burner's control phase (e.g. startup phase: short running time; operation: long running time).

