



SKD62UA Series Electronic Valve Actuator, Advanced Features

Product Description

The SKD62UA electronic valve actuator requires a 24 Vac supply and receives a 0 to 10 Vdc or 4 to 20 mA control signal to proportionally control a valve. These actuators are designed to work with the Flowrite™ VF599 series valves, or other manufacturer's valves with fitted with the appropriate Universal Valve Retrofit Kit.

Product Numbers

SKD62UA

Warning/Caution Notations

WARNING:		Personal injury or loss of life may occur if you do not follow a procedure as specified.
CAUTION:		Equipment damage, or loss of data may occur if you do not follow a procedure as specified.

Required Tools

- 5 mm hex wrench
- Small and medium flat-blade screwdrivers

Expected Installation Time

20 minutes for factory installed actuator
45 minutes for field replacement of actuator

Prerequisites



WARNING:

If mounting the actuator to a valve already in line, either close the shut-off valves in the piping (upstream first, then downstream) or switch off the pump to allow the differential and static pressure in the valve to drop.

Mounting Positions

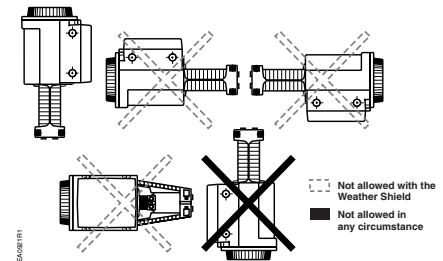

Figure 1. Acceptable Mounting Positions.

Using the Weather Shield

The SKD62UA must be in the vertical position. Complete instructions for the mounting of the weather shield are included with that product.

NOTE: Use the top knockout position when installing the Weather Shield. See Figure 13.

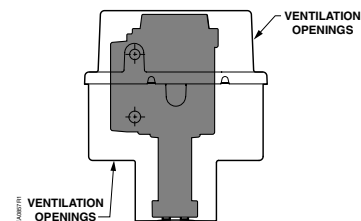

Figure 2. Weather Shield Installation Position.

Installation

If you are mounting an actuator on a new valve, begin with the instructions in Figure 3.

Removing the Actuator from the Valve

1. Remove the actuator cover.
2. Disconnect the wires and conduit, if installed.
3. Loosen the valve stem retainer using a 5 mm hex wrench and lower the valve stem into the valve.
4. Loosen the yoke nuts in the actuator yoke using a 5 mm hex wrench.
5. Remove the actuator from the valve, use care not to damage the valve stem.

Continue with *Mounting an Actuator to a Valve*.

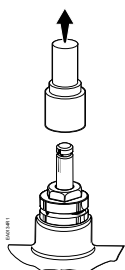

Figure 3. Preparing a new Valve.

Mounting an Actuator to a Valve.

NOTE: Install the packing heating element, (P/N 599-00417), if used, before proceeding.

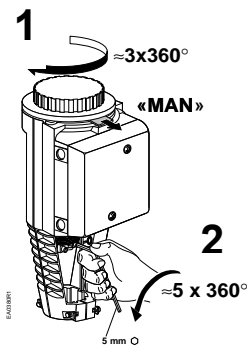

Figure 4.

NOTE: Make sure the yoke nuts are loose enough to allow the actuator to slip over the bonnet. See Figure 5.

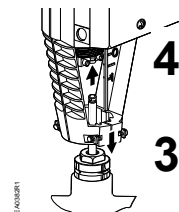

Figure 5.

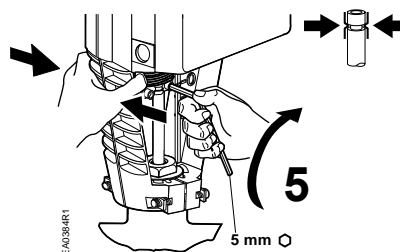

Figure 6.

NOTE: Hold the stem retainer in place as you tighten it around the valve stem. See Figure 6.

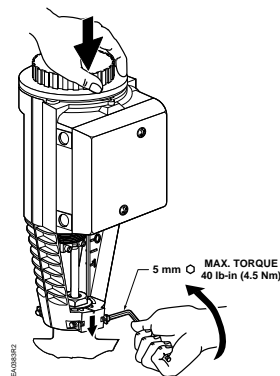

Figure 7.

NOTE: Position the actuator to accommodate the wiring. Hold the actuator in place while tightening the yoke nuts. See Figure 7.

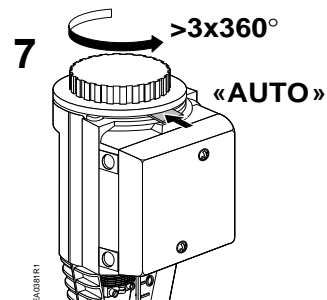

Figure 8.

Siemens Building Technologies, Inc.

Wiring



CAUTION:
 Use care when removing the knockout.
 Do not damage the circuit board.

Do not use autotransformers. Use earth ground isolating step-down Class 2 transformers.

Determine supply transformer rating by summing total VA of all actuators used. The maximum rating for a Class 2 power supply circuit is 100 VA.

Actuator	Power Consumption	Actuators per Class 2 supply circuit* (80% of transformer VA)
SKD62UA	17 VA	4

* Operating more actuators requires additional transformers or separate 100 VA power supplies.

Wiring Diagrams

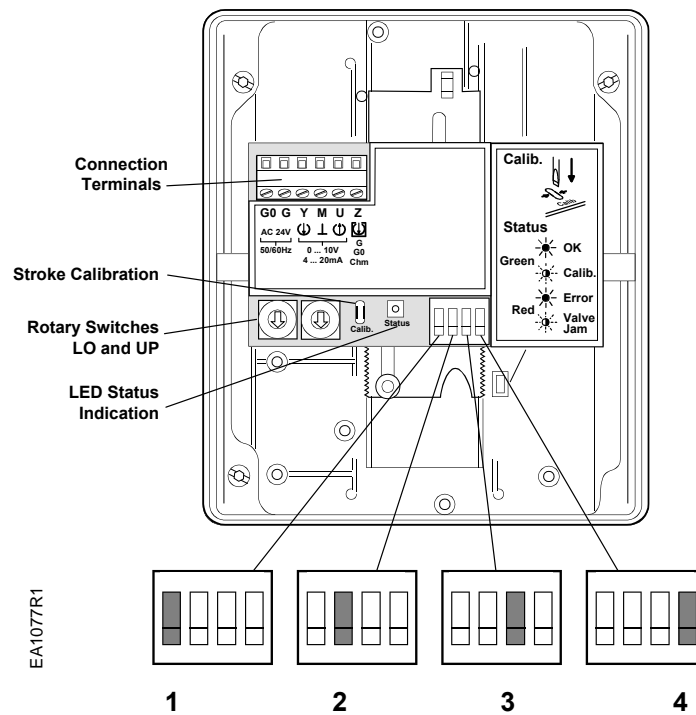

Figure 9. DIP Switches.

DIP Switches (From Left to Right)	1 Select Direction of Operation	2 Sequence Control or Stroke Limit Control	3 Selection of Control Signal	4 Selection of Flow Characteristic
ON	Reverse-acting	Sequence control	4 to 20 mA	Modified*
OFF (Factory Settings)	Direct-acting	Stroke limit control	0 to 10 Vdc	Default

*Changing the default setting will modify an equal percentage valve to a linear flow characteristic. When set to default, the flow characteristic is determined by the valve body.

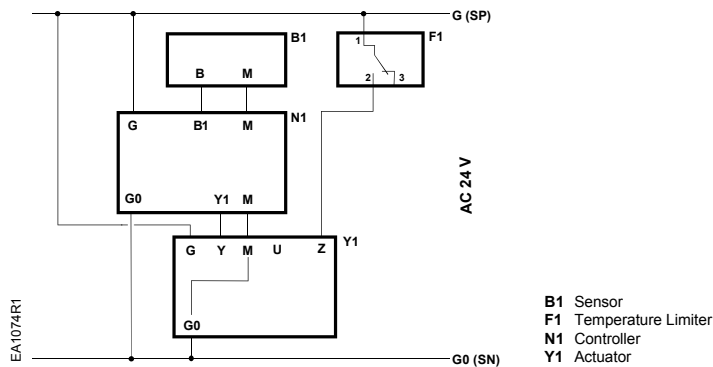

Figure 10.

Connecting Terminals

24 Vac	
G	System Potential (SP)
G0	System Neutral (SN)
Y	Control Input: 0 to 10 Vdc or 4 to 20 mA (DIP switch selectable)
Z	Override Control (See <i>Technical Instructions 155-717</i>)
M	Measuring Neutral
U	Output for 0 to 10 Vdc or 4 to 20 mA measuring voltage. It will match the input signal type.

The position output signal U will switch from 0 to 10 Vdc to 4 to 20 mA when a 4 to 20 mA input signal is selected and used on the terminal.

Start Up

- Check the wiring for proper connections.
- Consult the Technical Instructions 155-717 for detailed commissioning instructions.

Stroke Calibration

To determine the stroke positions 0 and 100% in the valve, calibration is required when the valve/actuator are commissioned for the first time.

The actuator must be mechanically connected to a valve and must have a supply voltage of 24 Vac. The calibration procedure can be repeated as often as necessary.

To initiate the calibration procedure, short circuit the contacts inside the slot located on the printed circuit board (with a screwdriver).

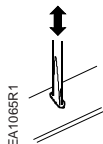

Automatic calibration proceeds as follows:

- Actuator runs to the 0 stroke position (1) the green LED flashes .
- Actuator then runs to the 100% stroke position (2) the green LED flashes.
- Measured values are stored in the EPROM.
- The actuator now moves to the position defined by control signal Y or Z (3), and the green LED now glows steady (normal operation)
- Throughout this procedure, output U is inactive, meaning the values only represent actual positions when the green LED stops flashing and remains on continually.

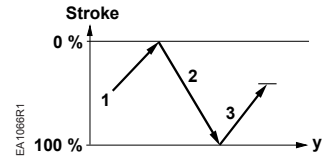

Table 1. LED Status.

LED	Display	Function	Action
Green	ON	Normal Operation	Automatic operation
	Flashing	Stroke calibration In Progress	Wait for calibration to be completed (LED stops flashing)
Red	ON	Faulty stroke calibration	- Check mounting - Restart stroke calibration (by short-circuiting calibration slot)
		Internal Error	- Replace electronics
	Flashing	Inner valve jammed	Check the valve
Red	OFF	• No power supply	-Check mains -Replace electronics
		• Faulty electronics	



CAUTION:

Before starting calibration, be sure that the manual adjuster is set to **Automatic** to register the actuator values.

Normally Closed Valve

- Actuator pressure cylinder moves:
- Outward (0 to 1): Valve opens.
 - Inward (1 to 0): Valve closes.

Normally Open Valve

- Actuator pressure cylinder moves:
- Outward (0 to 1): Valve closes.
 - Inward (1 to 0): Valve opens.

Three-Way Valve

- Actuator pressure cylinder moves:
- Outward: Valve opens between port NC and C.
 - Inward: Valve opens between ports NO and C.

NOTE: The valve body assembly determines the complete assembly action.

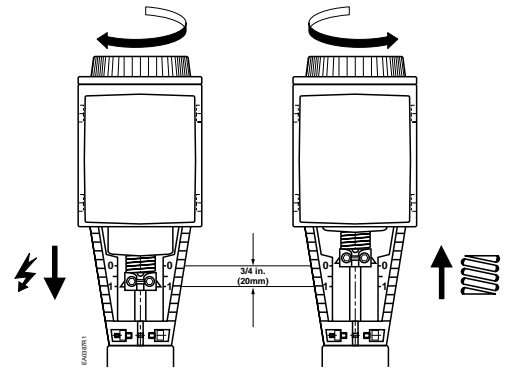

Figure 12. Valve Stem Travel Indication.

Manual Operation

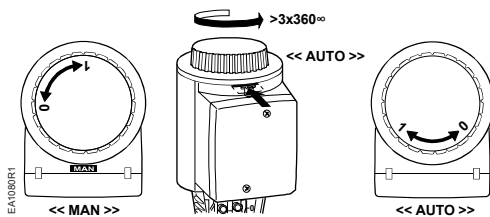

Figure 11. Manual Override in Manual and Automatic Position.

Each complete revolution (360°) is equal to 3/32-inch (2.5 mm) stroke.

Reference

Technical Instruction
 EA599-18 Flowrite 599 Series SKB/C/D
 62UA Series Electronic Valve Actuator, 24
 Vac Proportional Control Advanced Features

**Document
 Number**
 155-717

Dimensions

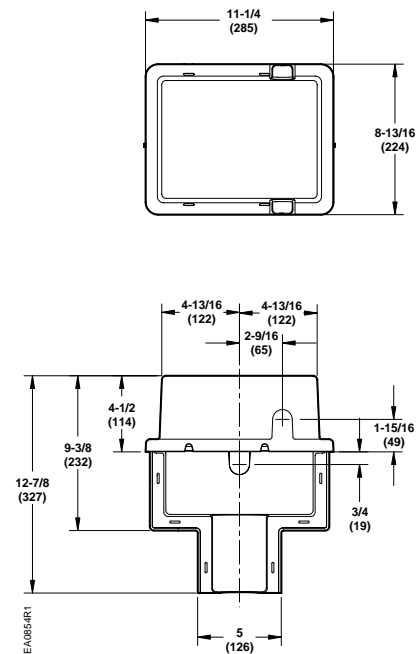

Figure 13. 599-10071 Weather Shield Dimensions in Inches (Millimeters).

Dimensions, Continued



CAUTION:
Use care when removing the knockout. Do not damage the circuit board.

NOTE: Use the top knockout position when installing the Weather Shield.

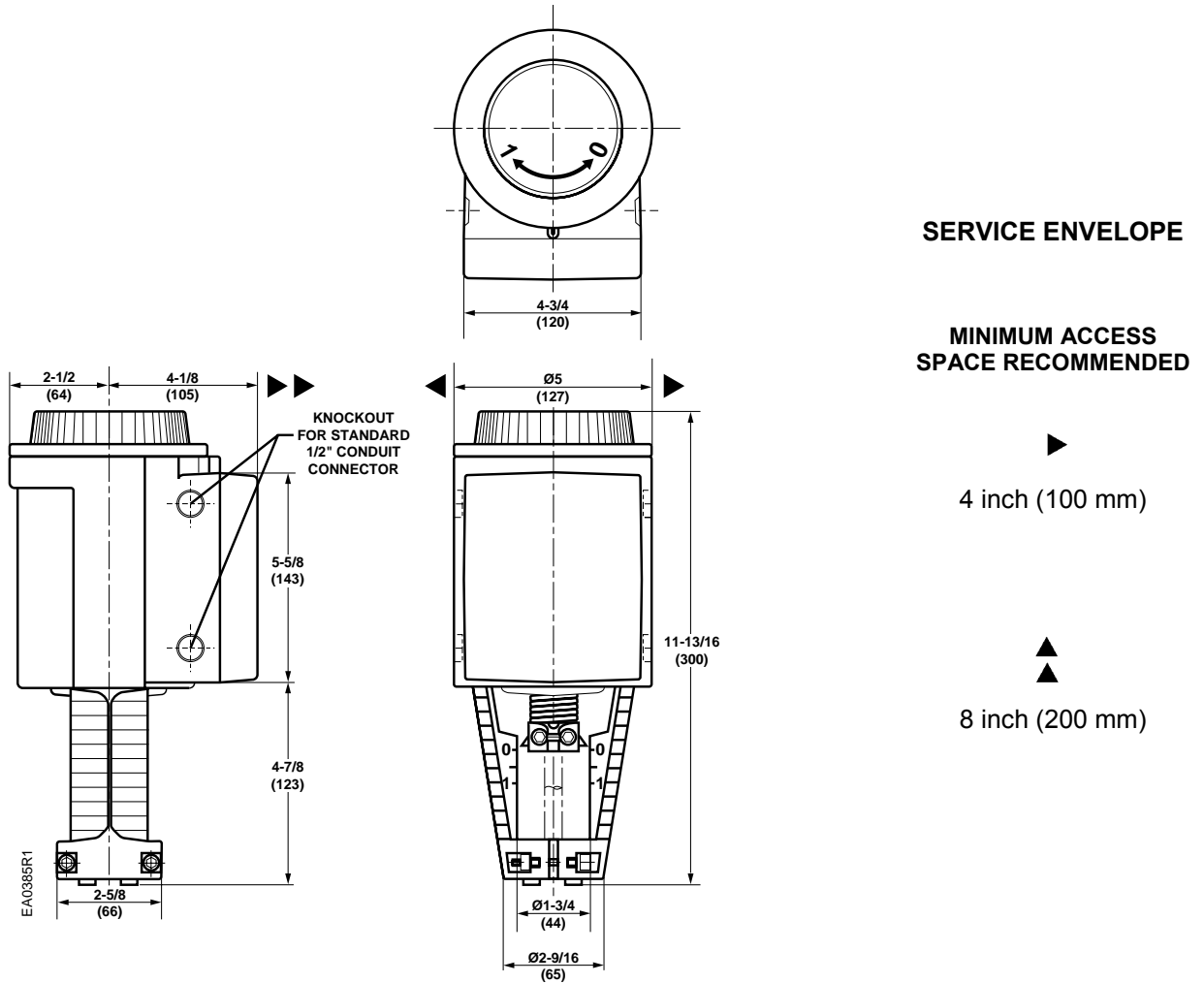

Figure 14. SKD62UA Dimensions in Inches (Millimeters).

Information in this publication is based on current specifications. The company reserves the right to make changes in specifications and models as design improvements are introduced. Flowrite is a trademark of Siemens Building Technologies, Inc. Other product or company names mentioned herein may be the trademarks of their respective owners. © 2002 Siemens Building Technologies, Inc.