

GDS-10000-01

Sensus QR-S



Call your sales representative to see for yourself.

805 Liberty Boulevard
DuBois, PA 15801
1-800-375-8875
www.sensus.com/gas

Benefits

- Enhanced response time
- Eliminates extreme pressure drop at start-up
- Easy field retrofit
- Cost effective solution
- Patent pending design
- Set pressure adjustable with QR-S installed
- Rated to 25 psig MAOP

Applications

- HE Boilers
- HE Burners
- HE Generators



Install High-Efficiency Burners or Boilers in Existing Pipe Configurations

The Sensus QR-S is a mechanical damping device that enhances gas pressure regulator response to meet the instantaneous ignition requirements of high-efficiency gas equipment.

Whether you're replacing older burners and boilers or installing new high-efficiency units, existing pipe configurations and other equipment can impact operation. That's because electronic ignitions on high-efficiency equipment can create negative pressure

in the line as gas is quickly drawn into the combustion chamber. The immediate call for gas can exceed pressure regulator settings, resulting in high lock-up or excessive pressure drop conditions that terminate ignition.

The QR-S is a simple solution that maintains precise pressure without negatively impacting high-efficiency burner or boiler operation.

Physical Characteristics

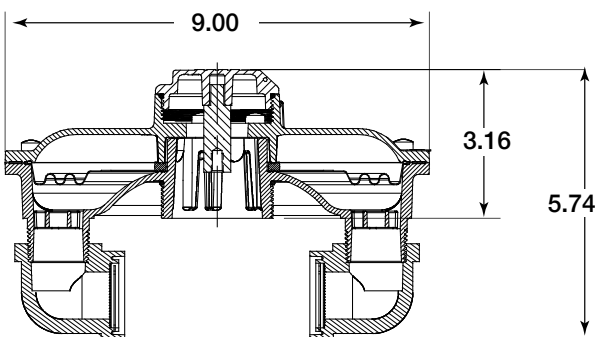

Regulator Compatibility

The QR-S is compatible with the regulator models listed below. For other models, variations and body styles, please contact your Sensus representative.

Model	Variations	Body Style
121-8	Standard	3/4" x 1, 1", 1-1/4", 1-1/2", 2", 2-1/2"
121-12	Standard	1-1/4", 1-1/2", 2", 2-1/2"
122-8	Standard	1", 1-1/4"
122-12	Standard	1-1/2", 2", 2-1/2"
243-8	-1, -2, -1M, -2M	1-1/4", 1-1/2", 2"
243-12	-2, -2M	1-1/4", 1-1/2", 2"
243-12	-1, -1M	1-1/4", 1-1/2", 2"