



Presentation example PME7...

Presentation example LME7...

PME73.810...

Program module for burner control LME73.000

User Documentation

Application:

- 1-stage / 2-stage or modulating, direct ignited forced draft burners
- Integrated actuator control via 3-position controller or analog signal (feedback potentiometer in the actuator required)
- Integrated valve proving (can be parameterized)
- Prepurge position in high-fire or low fire
- E.g. for burners to EN 676

The PME7... and this User Documentation are intended for use by OEMs which integrate the LME7... with PME7... in their products.



Note!

This documentation is only valid together with LME7... Basic Documentation (P7105)!

Contents

1	Supplementary documentation	3
2	Warning notes	4
3	Typographical conventions	4
4	Program sequence PME73.810.....	5
5	List of phase display	6
6	Fuel trains (examples)	8
6.1	Gas direct ignition (G), 1-stage	8
6.2	Gas direct ignition (G), 2-stage	8
6.3	Gas direct ignition (G), 1-stage, with valve proving	8
6.4	Gas direct ignition (G), 2-stage, with valve proving	9
7	Gas valve proving.....	10
8	Input gas pressure switch-min	12
9	Connection diagram for LME72.000... with actuator SQM4... ..	13
10	Time table and settings	14
11	Inputs and outputs / internal connection diagram	16
12	Parameter list (AZL2...).....	17
13	Error code list.....	20
14	Legend	21
15	List of figures	22

1 Supplementary documentation

Product type	Type of documentation	Documentation number
LME...	Environmental Product Declaration	E7105
PME...	Environmental Product Declaration	E7105.1
LME7...	Data Sheet	N7105
LME...	Product Range Overview	Q7010
LME7	Basic Documentation	P7105

2 Warning notes



Warning!

The safety, warning and technical notes given in the Basic Documentation on the LME7... (P7105) apply fully to the present document also!

To avoid injury to persons, damage to property or the environment, the following warning notes must be observed!

The LME7... are safety devices! Do not open, interfere with or modify the unit. Siemens does not assume responsibility for damage resulting from unauthorized interference!

3 Typographical conventions

Safety notes

This User Documentation contains notes which must be observed to ensure your personal safety and to protect the product and the connected equipment. The instructions and notes are highlighted by warning triangles or a hand symbol and are presented as follows, depending on the hazard level:



Warning

means that death, severe personal injury or substantial damage to property **can** occur if adequate precautionary measures are not taken



Note

draws your attention to **important information** on the product, on product handling, or to a special part of the documentation

Qualified personnel

Only **qualified staff** are allowed to install and operate the equipment. Qualified staff in the context of the safety-related notes contained in this document are persons who are authorized to commission, ground and tag devices, systems and electrical circuits in compliance with established safety practices and standards.

Correct use

Note the following:

The device may only be used on the applications described in the technical documentation and only in connection with devices or components from other suppliers that have been approved or recommended by Siemens.

The product can only function correctly and safely if shipped, stored, set up and installed correctly, and operated and maintained as specified.

4 Program sequence PME73.810...

→ For fuel trains **G** without or with valve proving

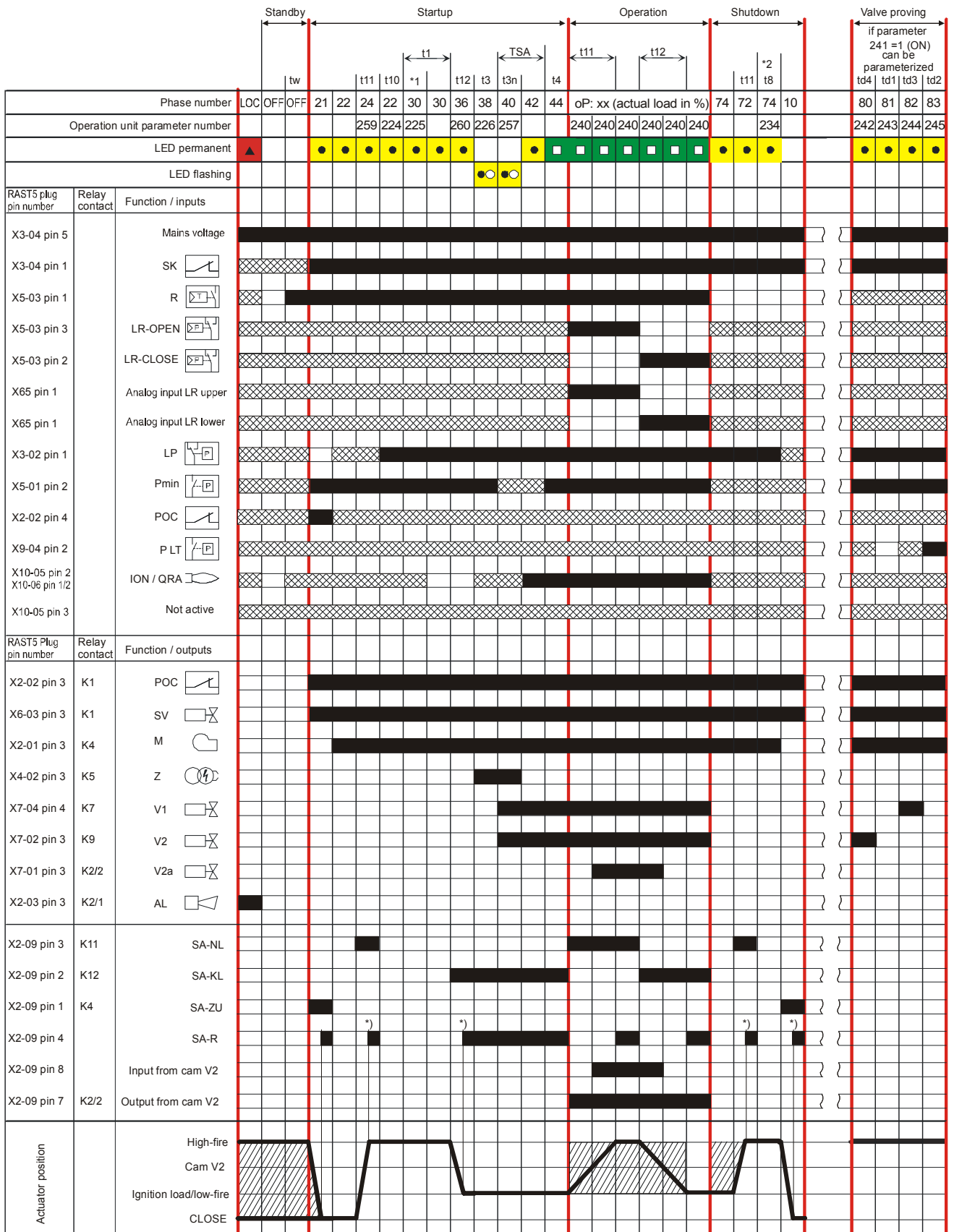

7105d74e/0312

Figure 1: Program sequence

*) During the actuator's running phases, the actuator's feedback signal must first be OFF, then ON

5 List of phase display

Phase number of display		LED	Function
7-segment	AZL2...		
LOC	LOC	OFF	Lockout phase
Standby			
OFF	OFF	OFF	Standby, waiting for heat request
P08	Ph08	OFF	Power ON/test phase (e.g. detector test)
Startup			
P21	Ph21	Yellow	Safety valve ON, air pressure switch in no-load position Test if POC closed (timeout/lockout after 5 seconds) Actuator travels to the closed position
P22	Ph22	Yellow	Part 1: Fan motor ON Part 2: Specified time air pressure switch Message (timeout), stabilization air pressure switch
P24	Ph24	Yellow	Actuator travels to the prepurge position (timeout)
P30	Ph30	Yellow	Part 1: Prepurge time without extraneous light test Part 2: Prepurging with extraneous light test (2.1 seconds)
P36	Ph36	Yellow	Actuator travels in ignition load position (timeout)
P38	Ph38	Yellow flashing	Preignition time
P40	Ph40	Yellow flashing	Postignition time
P42	Ph42	Green	Flame detection
P44	Ph44	Green	Interval: End of safety time and load controller release
Operation			
xx	oP:xx	Green	Operation (modulation), display of actual load in percent (%)
Shutdown			
P10	Ph10	OFF	Home run
P72	Ph72	Yellow	Actuator travels in postpurge position (timeout)
P74	Ph74	Yellow	Postpurge time *2
Valve proving			
P80	Ph80	Yellow	Test space is evacuated
P81	Ph81	Yellow	Test atmospheric pressure
P82	Ph82	Yellow	Test space is filled
P83	Ph83	Yellow	Test gas pressure
Safety shutdown phases			
P01	Ph01	Yellow / red	Under voltage / over voltage
P02	Ph02	Yellow	Safety shutdown (e.g. open safety loop) → lockout
P04	Ph04	Green / red	Extraneous light in standby
P90	Ph90	Yellow	Gas pressure switch-min open → safety shutdown and start prevention

*1	Valve proving during prepurging, if - parameter 241.00 = 1 and parameter 241.02 = 1 or - parameter 241.00 = 1 and parameter 241.01 = 0 or - parameter 234 (postpurge time) = 0 seconds
*2	Valve proving during postpurging, if - parameter 241.00 = 1 and parameter 241.02 = 1 or - parameter 241.00 = 1 and parameter 241.01 = 1 and - parameter 234 (postpurge time) >0 seconds

6 Fuel trains (examples)

6.1 Gas direct ignition (G), 1-stage

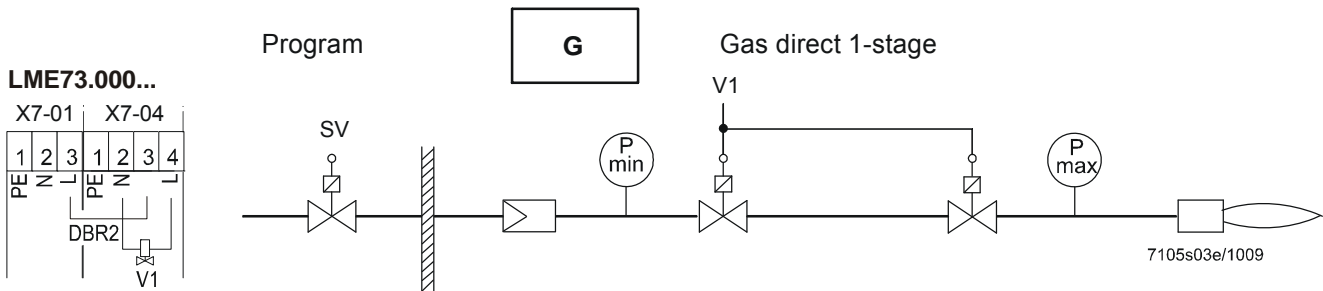

Figure 2: Fuel train gas direct ignition (G), 1-stage

6.2 Gas direct ignition (G), 2-stage

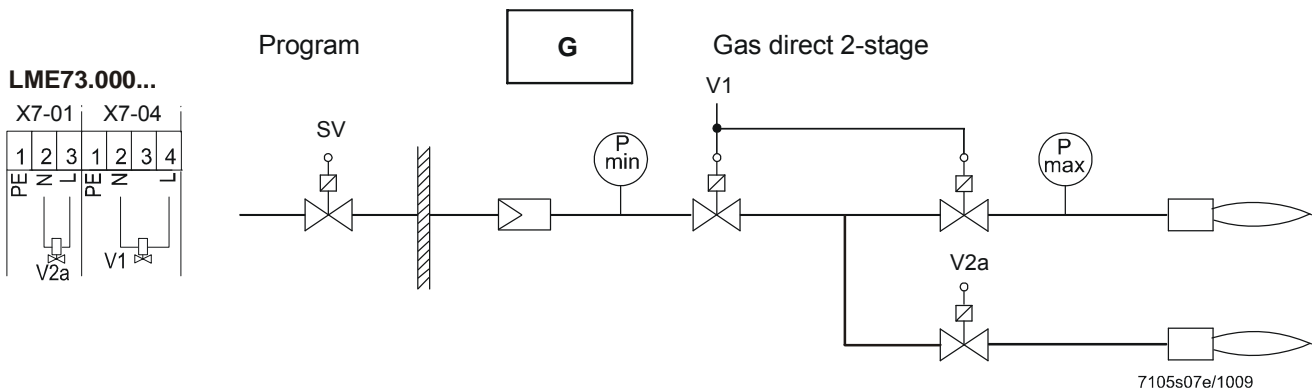

Figure 3: Fuel train gas direct ignition (G), 2-stage

6.3 Gas direct ignition (G), 1-stage, with valve proving

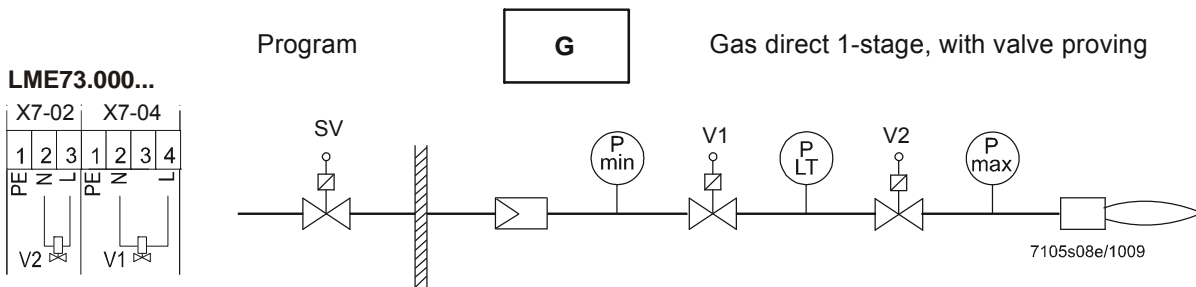

Figure 4: Fuel train gas direct ignition (G), 1-stage, with valve proving

6.4 Gas direct ignition (G), 2-stage, with valve proving

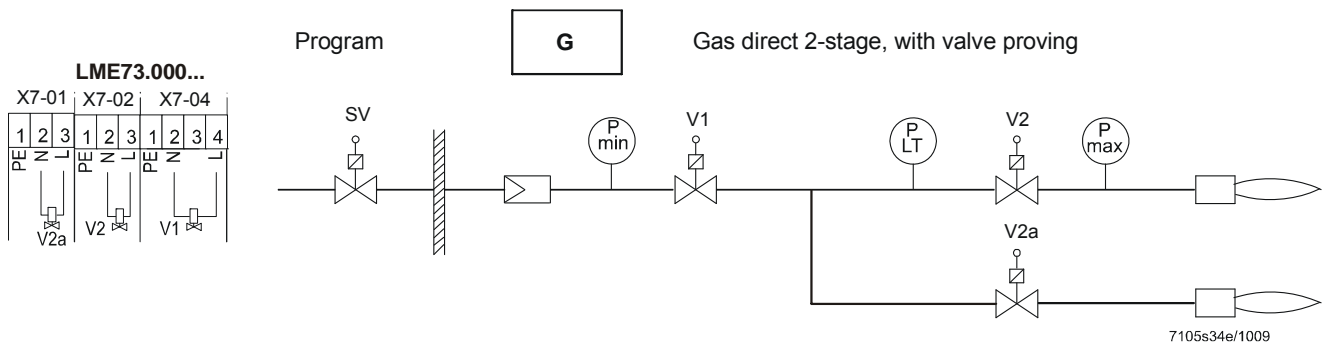

Figure 5: Fuel train gas direct ignition (G), 2-stage, with valve proving



Note:

When valve proving is activated (e.g. on shutdown), the load on the valve's terminals is restricted.

Fuel valve 1 terminal X7-04 pin 4 or fuel valve 2 terminal X7-02 pin 3

- Rated voltage AC 120 V AC 230 V
- Rated current 50/60 Hz 50/60 Hz
- Rated current 1 A 1 A
- Power factor $\cos\varphi > 0.4$ $\cos\varphi > 0.4$

If the terminal load (according to chapter *Technical Data – Terminal load of outputs*) is not reduced (max. rated current 2 A, $\cos\varphi > 0.4$), the design lifetime will be reached after about 100,000 burner startup cycles!

7 Gas valve proving

Valve proving is dependent on parameter 241. It is employed to detect leaking gas valves and, if necessary, to prevent the valves from opening or ignition from being switched on. Lockout is initiated.

Valve proving with separate pressure switch

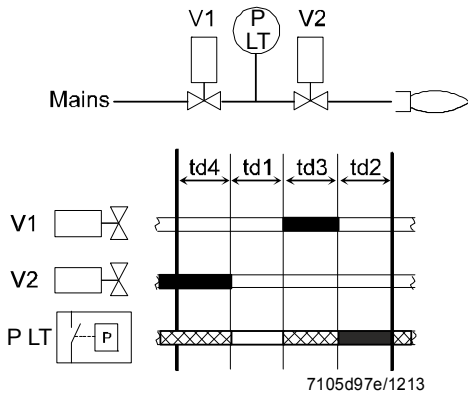

Fig. 6: Valve proving with separate pressure switch

Step 1: td4 – test space evacuating.

Gas valve on the burner side is opened to bring the test space to atmospheric pressure.

Step 2: td1 – test atmospheric pressure.

When the gas valve has closed, the gas pressure in the test space must not exceed a certain level.

Step 3: td3 – test space filling.

Gas valve on the mains side opens to fill the test space.

Step 4: td2 – test gas pressure.

When the gas valve has closed, the gas pressure in the test space must not drop below a certain level.

Legend

td1	Test atmospheric pressure
td2	Test gas pressure
td3	Test space filling
td4	Test space evacuating
V...	Fuel valve
P LT	Pressure switch valve proving
	Input/output signal 1 (ON)
	Input/output signal 0 (OFF)
	Input permissible signal 1 (ON) or 0 (OFF)

Query logic of gas pressure switch for gas valve proving:

- Gas pressure present → pressure switch closed
- Gas pressure not present → pressure switch open

Valve proving can be parameterized to take place on startup, shutdown, or both.

Recommendation:

Perform valve proving on shutdown.

No.	Parameter
241.00	Valve proving 0 = OFF 1 = ON ¹⁾
242	Valve proving test space evacuating
243	Valve proving time test atmospheric pressure
244	Valve proving test space filling
245	Valve proving time test gas pressure

¹⁾ Valve proving during postpurging, if parameter 234 >0 (postpurge time) and parameter 241.01 = 1

Program sequence with gas valve proving

During startup	<p>Gas valve proving during startup is performed only after a reset from the lockout position, after power ON, and when parameter 234 = 0 seconds.</p> <p>In that case, gas valve proving takes place at the same time as prepurging. This means that the prepurge time corresponds to at least the sum of all 4 gas valve proving parameters (242, 243, 244, and 245).</p>
During shutdown	<p>Gas valve proving during shutdown is performed only if the postpurge time >0 (parameter 234 >0). If no postpurge time is parameterized, gas valve proving takes place during startup when prepurging.</p> <p>During shutdown (heat request OFF), it is checked if parameter 241 = 1 (valve proving ON) and parameter 234 ≠ 0 seconds before the valves close.</p> <p>This means that, first, fuel valve 1 is closed. Fuel valve 2 remains open, so that the remaining gas in the test space can be burned. The postpurge time runs at the same time as valve proving. This means that the postpurge time corresponds to at least the sum of all 4 valve proving parameters (242, 243, 244, and 245).</p> <p>Prior to postpurging and valve proving, the actuator travels to the high-fire position.</p>



Warning!

The OEM must set the evacuation, filling and test times for atmospheric or mains pressure on every plant in compliance with the requirements of EN 1643. If not observed, there is a risk of impairment of safety functions.

It must be ensured that the 2 test times are correctly set. It is to be checked whether the gas required for the test may be fed into the combustion chamber (on the relevant application). The test times are safety-related. After a reset and in the case of aborted or prevented valve proving, the unit will perform valve proving the next time it is started up (only when valve proving is activated). In the case of valve proving, prepurging is active during the startup phase, even if it has been deactivated.

Examples of aborted valve proving:

When the safety loop or the start prevention input for gas (containing pressure switch-min) opens during valve proving.

Valve proving – calculation of leakage rate

$$t_{\text{Test}} = \frac{(P_G - P_W) \cdot V \cdot 3600}{P_{\text{atm}} \cdot Q_{\text{Leck}}}$$

QLeck	in l/h	Leakage rate in liters per hour
P _G	in mbar	Overpressure between the valves at the beginning of the test phase
P _W	in mbar	Overpressure set on the pressure switch (normally 50% of the gas inlet pressure)
P _{atm}	in mbar	Absolute air pressure (1013 mbar normal pressure)
V	in l	Volume between the valves (test volume) including valve volume and pilot pipe, if present
t _{Test}	in s	Test time

8 Input gas pressure switch-min

Behavior in the event gas pressure switch-min fails (terminal X5-01 pin 2 and pin 3)

If gas pressure switch-min fails, safety shutdown is triggered and startup prevented until gas pressure switch-min closes again. During start prevention, the yellow LED is lit and the safety circuit is active. Burner control operates in phase 90.

9 Connection diagram for LME72.000... with actuator SQM4...

Note:
The connection diagram shown is merely an example which must be verified in the individual case depending on the application!

**PME73.810... 1-stage or 2-stage modulating
Without pilot ignition
With or without valve proving**

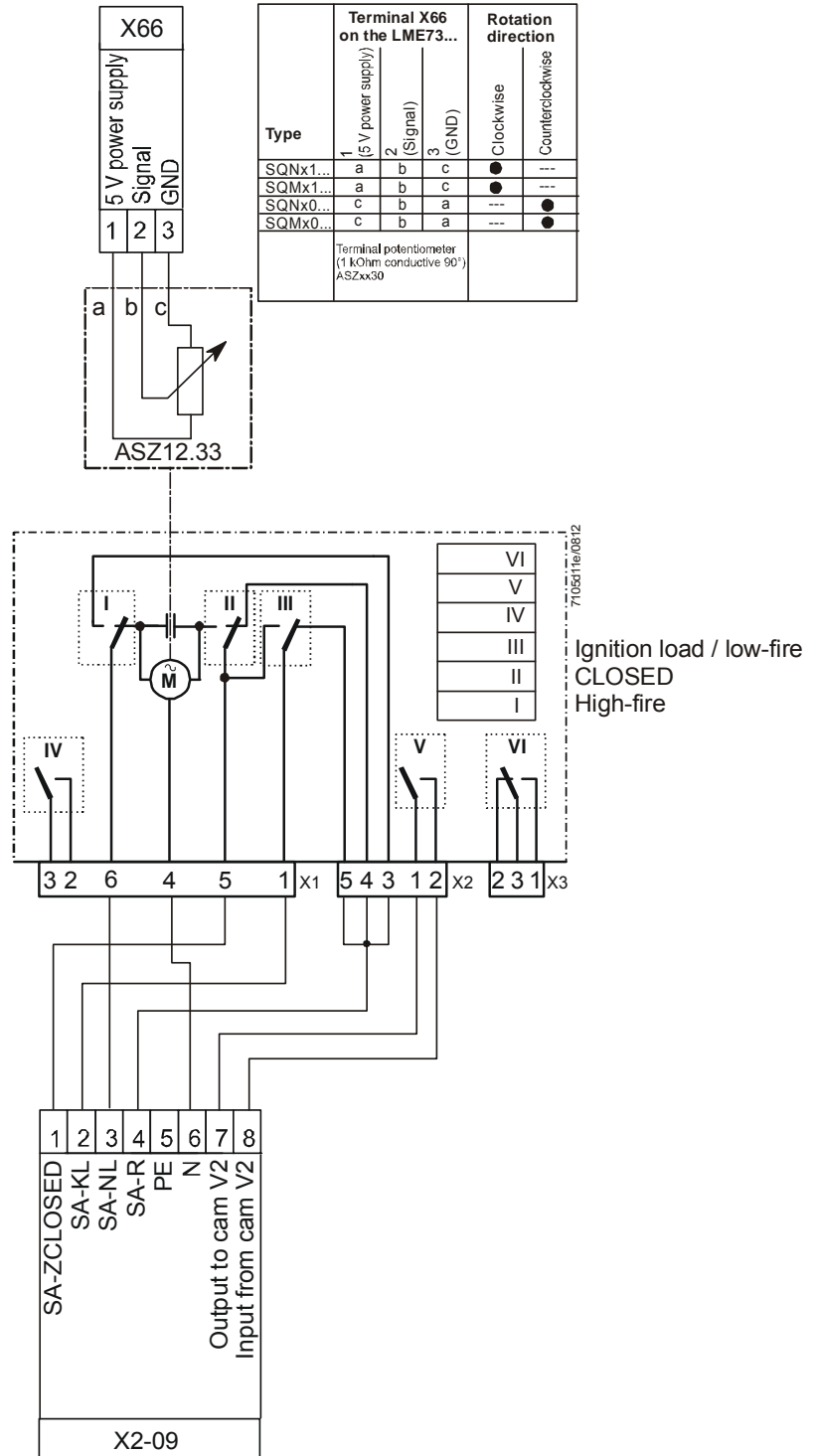

Figure 7: Connection diagram for LME73.000... with actuator SQM4...

10 Time table and settings

Type	Times in seconds														
	tw	TSA max.	t1 P225 4) min.	t3 P226 min.	t3n P257 approx.	t4 P230 min.	t8 P234 5) min.	t10 P224 approx.	t11 P259 approx.	t12 P260 approx.	1)	2)	3)	td1 P243 td2 P245 min.	td3 P244 td4 P242 max.
Requirements	2.5	3	30	6	2.5	9	15	15	300	300	---	---	---	10	3
Factory setting	---	t3n+0.45	29.106+2.1	6.174	2.205+0.3	9.408	19.404	13.818	300.762	300.762	---	---	---	10.29	2.646
Max.	2.5	14	1237+2.1	37.485	13.23+0.3	74.97	1237	13.818	1237	1237	1	0.45	0.45	37.485	2.646
Min.	---	---	0+2.1	1.029	0+0.3	3.234	0	0	0	0	0.3	0.3	---	1.029	0
Step size	---	---	4.851	0.147	0.147	0.294	4.851	0.294	4.851	4.851	---	---	---	0.147	0.147

Function parameter	Parameter number	Factory setting
Repetition in the event of lost of flame during operation 0: None 1: None 2: 1 x repetition	240	0
Valve proving 0: OFF 1: ON	241.00	1
Valve proving 0: During prepurge time 1: During postpurge time	241.01	1
Valve proving 0: According to parameter 241.01 1: During prepurge time and postpurge time	241.02	0
Actuator position during prepurge time and postpurge time 0: Purging in low-fire 1: Purging in high-fire	515	1

Legend

tw	Waiting time
TSA	Safety time
t1	Prepurge time
t3	Preignition time
t3n	Postignition time parameter 257 +0.3 seconds
t4	Interval: End of safety time - load controller release
t8	Postpurge time
t10	Specified time air pressure switch message (timeout)
t11	Opening time of actuator (timeout)
t12	Closing time of actuator (timeout)
td1	Test atmospheric pressure
td2	Test gas pressure
td3	Test space filling
td4	Test space evacuating
1)	Reaction time to a change of signal by the air pressure switch contact (opens) and flame-out response time in the event of loss of flame
2)	Reaction time to a change of signal by the inputs (e.g. pressure switch-min)
3)	Flame detection time
4)	Minimum time $td1 + td2 + td3 + td4$ if: Parameter 241.00 = 1 (ON, after mains ON, with lockout, parameter 234 (postpurge time) = 0 (postpurging) or parameter 241.01 = 0
5)	Minimum time $td1 + td2 + td3 + td4$ if: Parameter 241.00 = 1 (ON) and parameter 234 (postpurge time) >0 (postpurging) and parameter 241.01 = 1

11 Inputs and outputs / internal connection diagram

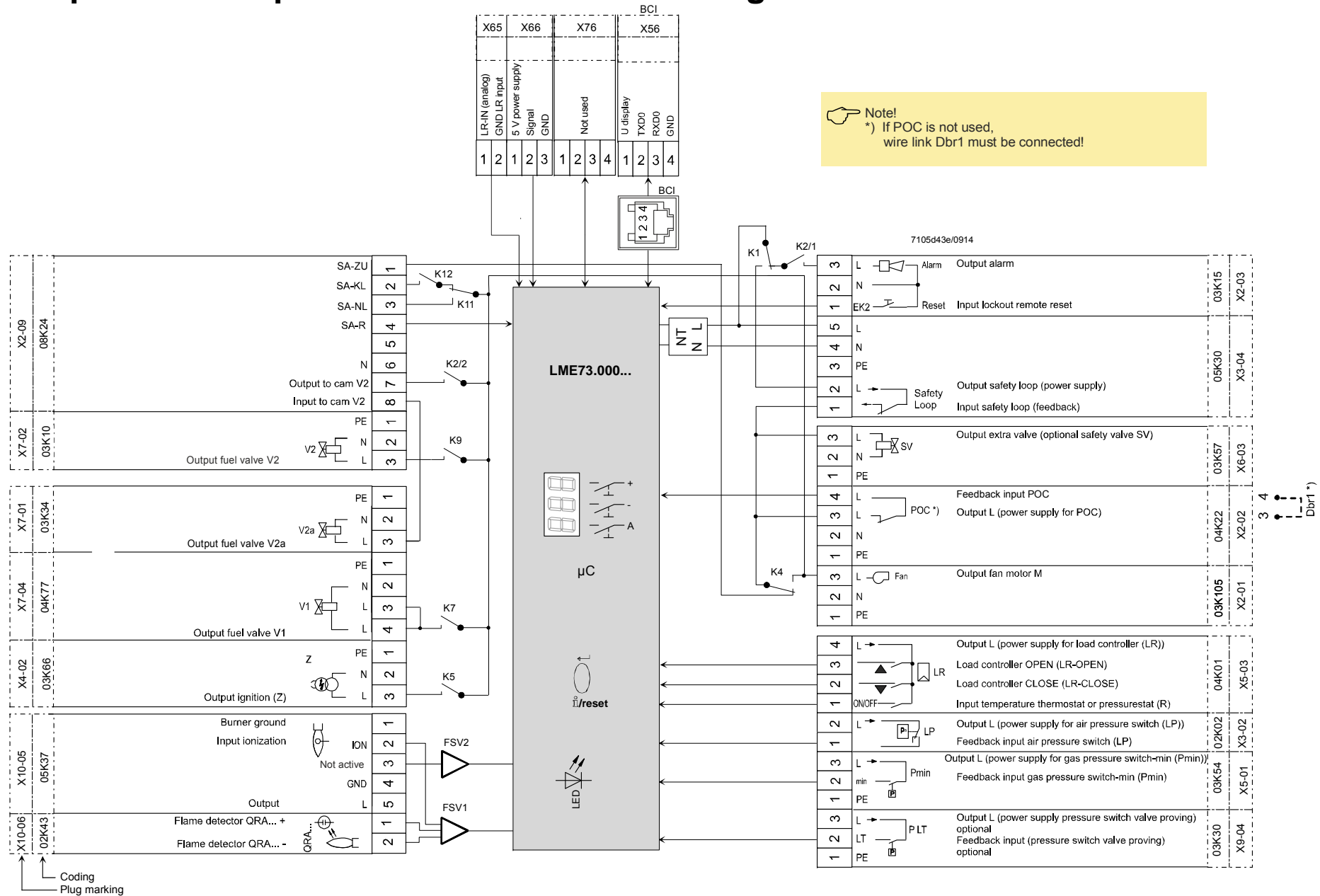

Figure 8: Inputs and outputs / internal connection diagram

12 Parameter list (AZL2...)

Parameter number	Parameter	Edit	Value range		Resolution	Factory setting	Password level reading from level	Password level writing from level
			Min.	Max.				
000	Internal parameter							
41	Heating engineer's password (4 characters)	Edit	xxxx	xxxx	---	---	---	OEM
42	OEM's password (5 characters)	Edit	xxxxx	xxxxx	---	---	---	OEM
60	Backup/restore	Edit	Restore	Backup	---	---	---	SO
100	General							
102	Identification date	Read only	---	---	---	---	Info	---
103	Identification number	Read only	0	9999	1	0	Info	---
113	Burner identification	Edit	x	xxxxxxx	1	burnErd	Info	SO
123	Min. power control step	Edit	1%	10%	0,1	2	SO	SO
140	Mode display of display and operating unit AZL2... 1 = standard (program phase) 2 = flame 1 (QRA.../ION) 3 = flame 2 (QRB.../QRC...) ⇒ not used 4 = active power (power value)	Edit	1	4	1	4	SO	SO
164	Number of startups resettable	Resettable	0	999999	1	0	Info	Info
166	Total number of startups	Read only	0	999999	1	0	Info	---
170.00	Switching cycles relay contact K12	Read only	0	999999	1	0	Info	---
170.01	Switching cycles relay contact K11	Read only	0	999999	1	0	Info	---
170.02	Switching cycles relay contact K2	Read only	0	999999	1	0	Info	---
170.03	Switching cycles relay contact K1	Read only	0	999999	1	0	Info	---
171	Max. switching cycles relay	Read only	0	999999	1	0	Info	---





Parameter number	Parameter	Edit	Value range		Resolution	Factory setting	Password level reading from level	Password level writing from level
			Min.	Max.				
200	Burner control							
224	Special time air pressure switch	Edit	0 s	13,818 s	0,294 s	13,818 s	SO	OEM
225	Prepurge time -2,1 seconds	Edit	0 s	1237 s	4,851 s	29,106 s	SO	OEM
226	Preignition time	Edit	1,029 s	37,485 s	0,147 s	6,174 s	SO	OEM
230	Interval: End of safety time - load controller release	Edit	3,234 s	74,97 s	0,294 s	9,408 s	SO	OEM
234	Postpurge time	Edit	0 s	1237 s	4,851 s	19,404 s	SO	OEM
240	Repetition in the event of loss of flame during operation 0 = none 1 = none 2 = 1 x Repetition	Edit	0	2	1	0	SO	OEM
241.00	Valve proving 0 = OFF 1 = ON	Edit	0	1	1	1	SO	OEM
241.01	Valve proving 0 = during prepurge time 1 = during postpurge time	Edit	0	1	1	1	SO	OEM
241.02	Valve proving 0 = according to parameter 241.01 1 = during prepurge time and postpurge time	Edit	0	1	1	0	SO	OEM
242	Valve proving test space evacuating	Edit	0 s	2,648 s	0,147 s	2,648 s	SO	OEM
243	Valve proving time test atmospheric pressure	Edit	1,029 s	37,485 s	0,147 s	10,290 s	SO	OEM
244	Valve proving test space filling	Edit	0 s	2,648 s	0,147 s	2,648 s	SO	OEM
245	Valve proving time test gas pressure	Edit	1,029 s	37,485 s	0,147 s	10,290 s	SO	OEM
257	Postignition time -0.3 seconds	Edit	0 s	13,23 s	0,147 s	2,205 s	SO	OEM
259	Opening time of actuator (timeout)	Edit	0 s	1237 s	4,851 s	300,762 s	SO	OEM
260	Closing time of actuator (timeout)	Edit	0 s	1237 s	4,851 s	300,762 s	SO	OEM
515	Actuator position during prepurge time and postpurge time 0: Purging in low-fire 1: Purging in high-fire	Edit	0	1	1	1	SO	OEM

Parameter number	Parameter	Edit	Value range		Resolution	Factory setting	Password level reading from level	Password level writing from level
			Min.	Max.				
600	Power setting							
654	Analog input (feedback potentiometer ASZxx.3x required) 0 = 3-position step input 1 = 0...10 V 2 = 0...135 Ω 3 = 0...20 mA 4 = 4...20 mA with lockout at I <4 mA 5 = 4...20 mA	Edit	0	5	1	1	SO	SO
700	Error history							
701	Current error: 00: Error code 01: Startup meter reading 02: HMI phase 03: Power value	Read only	2 0 --- 0%	255 999999 --- 100%	1 1 --- 1	---	Service	---
702	Error history former 1: 00: Error code 01: Startup meter reading 02: HMI phase 03: Power value	Read only	2 0 --- 0%	255 999999 --- 100%	1 1 --- 1	---	Service	---
• • •								
711	Error history former 10: 00: Error code 01: Startup meter reading 02: HMI phase 03: Power value	Read only	2 0 --- 0%	255 999999 --- 100%	1 1 --- 1	---	Service	---
900	Process data							
936	Normalized speed	Read only	0%	100%	0,01%	---	Service	---
951	Mains voltage	Read only	0 V	LME73.000A1: 175 V LME73.000A2: 350 V	1 V	---	Service	---
954	Flame intensity	Read only	0%	100%	1%	---	Service	---

13 Error code list

Error code		Clear text	Possible causes
AZL2...	7-Segment		
Loc: 2	Loc 2	No establishment of flame at the end of safety time	<ul style="list-style-type: none"> - Faulty or soiled fuel valves - Faulty or soiled flame detector - Poor adjustment of burner, no fuel - Faulty ignition equipment
Loc: 3	Loc 3	Air pressure faulty (air pressure switch welded in no-load position, decrease to specified time (air pressure switch flame-on response time))	Air pressure switch faulty <ul style="list-style-type: none"> - Loss of air pressure signal after specified time - Air pressure switch has welded in no-load position
Loc: 4	Loc 4	Extraneous light	Extraneous light during burner startup
Loc: 5	Loc 5	Air pressure faulty, air pressure switch welded in working position	Time supervision air pressure switch <ul style="list-style-type: none"> - Air pressure switch has welded in working position
Loc: 6	Loc 6	Fault of actuator	<ul style="list-style-type: none"> - Actuator faulty or blocked - Faulty connection - Wrong adjustment
Loc: 7	Loc 7	Loss of flame	Too many losses of flame during operation (limitation of repetitions) <ul style="list-style-type: none"> - Faulty or soiled fuel valves - Faulty or soiled flame detector - Poor adjustment of burner
Loc: 10	Loc 10	Error not relatable (application), internal error	Wiring error or internal error, output contacts, other faults
Loc: 12	Loc 12	Valve proving	Fuel valve 1 leaking
Loc: 13	Loc 13	Valve proving	Fuel valve 2 leaking
Loc: 14	Loc 14	POC error	Error valve closure control POC
Loc: 22	Loc 22	Safety loop open	<ul style="list-style-type: none"> - Gas pressure switch-max open - Safety limit thermostat cut out
Loc: 60	Loc 60	Analog power source 4...20 mA, I <4 mA	Wire breakage
Loc: 138	Loc 138	Restore process successful	Restore process successful
Loc: 139	Loc 139	No program module detected	No program module plugged in
Loc: 167	Loc 167	Manual locking	Manual locking
Loc: 206	Loc 206	AZL2... incompatible	Use the latest version
rSt Er1	rSt Er1	Error in compatibility program module to basic unit during restore process	<ul style="list-style-type: none"> - Program sequence of program module does not match the basic unit
rSt Er2	rSt Er2	Error in compatibility program module to basic unit during restore process	<ul style="list-style-type: none"> - Hardware of basic unit does not match the program module
rSt Er3	rSt Er3	Error during restore process	<ul style="list-style-type: none"> - Program module faulty - Program module removed during restore process
bAC Er3	bAC Er3	Fault of compatibility program module to basic unit during backup process	Program sequence of program module does not match the basic unit
Err PrC	Err PrC	Fault of program module	<ul style="list-style-type: none"> - Error in data content of program module - No program module fitted

14 Legend

AL	Alarm device
Dbr...	Wire link
 ↕/reset (EK1)	Lockout reset button (info button)
EK2	Remote lockout reset button
FSV	Flame signal amplifier
ION	Ionization probe
K...	Relay contact
LED	3-color signal lamp
LP	Air pressure switch
LR	Load controller
LR-OPEN	Load controller OPEN position
LR-CLOSED	Load controller CLOSED position
M	Fan motor
NT	Power supply unit
P LT	Pressure switch - valve proving
Pmax	Pressure switch-max
Pmin	Pressure switch-min
POC	Valve's closure control (proof of closure)
QRA...	Flame sensor
R	Control thermostat or pressurestat
SA	Actuator
SA-KL	Actuator low-fire
SA-NL	Actuator high-fire
SA-R	Actuator feedback
SA-CLOSED	Actuator CLOSED
SA-ZL	Actuator ignition load
SK	Safety Loop
SV	Safety valve
V1	Fuel valve
V2	Fuel valve
V2a	Fuel valve
Z	Ignition transformer
	Input/output signal 1 (ON)
	Input/output signal 2 (OFF)
	Permissible input signal 1 (ON) or 0 (OFF)

15 List of figures

Figure 1: Program sequence	5
Figure 2: Fuel train gas direct ignition (G), 1-stage.....	8
Figure 3: Fuel train gas direct ignition (G), 2-stage.....	8
Figure 4: Fuel train gas direct ignition (G), 1-stage, with valve proving	8
Figure 5: Fuel train gas direct ignition (G), 2-stage, with valve proving	9
Fig. 6: Valve proving with separate pressure switch.....	10
Figure 7: Connection diagram for LME73.000... with actuator SQM4... ..	13
Figure 8: Inputs and outputs / internal connection diagram	16