



Quick Reference

PAPERLESS RECORDER

Type : PHF

INP-TN1PHFQR-E

Fuji Electric Systems Co., Ltd.

Head office

Gate City Ohsaki, East Tower, 11-2, Osaki 1-chome,
Shinagawa-ku, Tokyo 141-0032, Japan
<http://www.fesys.co.jp/eng>

Instrumentation Div.

International Sales Dept.

No.1, Fuji-machi, Hino-city, Tokyo 191-8502, Japan
Phone: 81-42-585-6201, 6202 Fax: 81-42-585-6187
<http://www.fic-net.jp/eng>

Thank you for your purchasing Fuji Paperless Recorder (Type: PHF).

- Read this instruction manual carefully to ensure correct installation, operation and preparation. Incorrect handling may lead to accident or injury.
- Specifications of this unit are subject to change without prior notice for improvement.
- Modification of this unit without permission is strictly prohibited.
Fuji will not be bear any responsibility for a trouble caused by such a modification.
- This instruction manual should be kept by the person who is actually using the unit.
- After reading the manual, be sure to keep it at a place easy to access.
- This instruction manual should be delivered to the end user without fail.

Manufacturer : Fuji Electric Instrumentation Co., Ltd.
 Type : Shown on nameplate of Recorder
 Date of manufacture : Shown on nameplate of Recorder
 Product nationality : Japan

Note: Windows is a registered trademark of Microsoft Corporation.
 Modbus is a registered trademark of AEG Schneider Automation International.
 Other product names are registered trademarks or trademarks of each manufacturer.

CONTENTS

Specifications and Accessories	1	4. Display and Operation Procedure	8
Related Information	1	5. List of Parameters	9
Caution on Safety (Please read first)	2	6. Troubleshooting	11
For Proper Usage	5	7. Specifications	11
1. Installation	5	8. Code Symbols	12
2. Wiring	6	9. Maintenance	12
3. Operation Parts and Their Functions	7		

Specifications and Accessories

Before using the product, confirm that it matches the type ordered.

(For model code, please refer to page 12.)

Confirm that all of the following accessories are included.

Product name	Quantity
	Panel-mounted
(1) Panel-mounting bracket	2
(2) CD-ROM PC support software instruction manual	1
(3) Power supply noise filter	1
(4) Quick reference (this manual)	1

Related Information

Refer to the following reference materials for details about the items described in this manual.



Content	Document	Reference Number
Specifications	Catalogue	ECNO: 1014
Operation Method	Instruction Manual for Paperless Recorder (type: PHF)	INP-TN1PHF-E
Communication Function	Communication Functions Instruction Manual (Ethernet) for Paperless Recorder	INP-TN5A0072-E
Parameter Loader (software)	Parameter Loader Instruction Manual for Paperless Recorder	INP-TN513995-E
Data Viewer (software)	Data Viewer Instruction Manual for Paperless Recorder	INP-TN514013-E

Caution on Safety (Please read first)

Read this “Caution on Safety” carefully before using the instrument.

- Be sure to observe the instructions shown below, because they describe important information on safety. The degree of danger is classified into the following two levels: “DANGER” and “CAUTION.”

The signs and their meanings are as follows:

 DANGER	Improper handling may cause dangerous situations that may result in death or severe injury.
 CAUTION	Improper handling may cause dangerous situations that may result in moderate or light injuries or property damage.

1. DANGER

1.1 Installation

- This equipment is intended to be used under the following conditions.

Ambient temperature	0 to 50°C (without Ethernet function) 0 to 40°C (with Ethernet function)	
Ambient humidity	20 to 80% RH (with no condensation)	
Installation category	II	by IEC1010-1
Pollution degree	2	

- IP : 50 (Front) / 20 (Terminal)
- When there is a possibility that the abnormality of this instrument may cause a major accident or damage to other instruments, externally install an adequate emergency stop circuit or a protection circuit to prevent accidents.
- This product is provided with a built-in fuse that cannot be replaced by the customer. Therefore, we recommend you to separately provide adequate fuses externally. (Rating: 250V, 1A)

The details of the built-in fuse are as follows.

Type : TR-5 19372, 3.15A (Manufactured by Wickmann-Werke GmbH)

Rating : 250V, 3.15A, Type: T (Slow-blow type)

- Feed the power-supply voltage to specifications to prevent damages to and breakdown of the instrument.
- Never turn on the power before all the mounting and wiring work are finished to prevent electric shock, malfunction or failure of the instrument.
- Never use this instrument in an environment where flammable or explosive gases exist, since this is not of intrinsically safe construction.
- Never disassemble, remodel, modify, or repair this instrument. Otherwise malfunction, electric shock, or failure may result.
- Never touch the terminal while the instrument is being energized. Otherwise electric shock or malfunction may result.

1.2 Maintenance

- Turn off the power before attaching/detaching the module/unit. Otherwise electric shock, malfunction or failure may result.
- We recommend you to perform periodic maintenance for the safe and continuous use of this instrument, because consumable parts or those which deteriorate with time are mounted in this instrument.
- Do not block the ventilation holes at the top and the bottom of this instrument. Otherwise a failure, malfunction, shortened service life, or fire may result.

2. Caution

2.1 Cautions when installing

- Never use the instrument if it is found damaged or deformed when unpacked. Otherwise a fire, malfunction, or failure may result.
- Check that the instrument is to the proper specifications. Otherwise damage or failure may result.
- Do not give a shock to the instrument by falling or toppling it. Otherwise damage or failure may result.
- Avoid installing the instrument in the following places.
 - A place where the ambient temperature goes beyond the range from 0 to 50°C (0 to 40°C when the instrument is mounted with its side face closely contacted, or provided with Ethernet function)
 - A place where the ambient humidity goes beyond the range from 20 to 80% RH
 - A place where condensation occurs
 - A place where corrosive gases (sulfuric gases or ammonia, etc., in particular) or flammable gases exist
 - A place where vibration or impact may be applied to the instrument (permissible continuous vibration condition: 4.9 m/s² or lower)
 - A place subjected to water, oil, chemicals, vapor, or steam
 - A place subjected to dust and high in salt or iron content
 - A place where inductive interference may have a great effect, thus causing static electricity, magnetism, or noises
 - A place subjected to heat accumulation by radiant heat or the like
 - A place that is affected by electromagnetic wave from wireless machine or portable telephones.
- If the instrument is installed near other electronics instruments, such as TV in particular, noises may be caused. Take the following measures in these cases.
 - Place the instrument as far from the TV or the radio as possible (1m or more)
 - Change the orientation of the antenna of the TV or the radio.
 - Use separate receptacles.

2.2 Cautions when installing to the panel

- When mounting this instrument against the panel, pay attention not to apply stress to the case. Otherwise the case may be damaged.
- Fix the instrument by fastening the screws at the top and the bottom of the supplied mounting bracket.
- The panel to be used should be more than 2 mm thick.
- Excessive torque will cause damage to front panel frame or result in case deformation.
Tightening torque: 0.2 N·m
- If the panel front is subject to water splashes, use panel packing between the unit and panel.

- Mount the unit horizontally, with no tilt to the left or right (The forward tilt should be 0° but the unit may be inclined 0 to 30° rearwards).

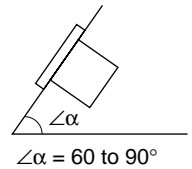

2.3 Cautions for wiring connection

- Only authorized workers should perform wiring. Improper wiring may cause fire, failure, or electric shock.
- Be sure to ground the instrument. Otherwise electric shock or malfunction may result.
- When cables are connected to terminals of the recorder unit, don't apply pulling force to them excessively. Excessive force to the terminal may result in damage to the terminal or cable.
- Use the power cable that has the performance equivalent to or higher than 600-V vinyl insulated power cable (JIS C3307). Install the attached noise filter within approximately 20cm from the power terminal of this instrument. (Wind the power cable 1 to 2 turns. The internal diameter of the ferrite core is 8mm.) Do not connect two or more instruments in parallel.
- Up to 2 solderless terminals should be used when connecting cables to terminals. Be sure to use an insulation cap.
(Note)
 - 1) At the completion of wiring of the input terminals, be sure to close the rear cover to ensure the compensation of reference contact when thermocouple input is used.
In case of thermocouple input, follow the steps to stabilize temperature at the terminal.
 - Be sure to attach input terminal cover.
 - Don't use a thick cable to prevent the effect of radiation. The cable with a diameter of 0.5 mm or less is recommended.
 - Don't mount other instruments near a fan to keep temperature stable.
 - 2) For connection of lead wires to terminals, use of sleeve-insulated clamping terminals (for M3 screw) is recommended.
 - 3) This unit has no power fuse which is removable. Mount a power fuse outside the unit as needed. Recommended fuse rating: 250V AC, 1A
 - 4) Don't loosen screws that are secured to the terminal case and power terminal.
- Input signal cables should be wired separately as far as possible (30 cm or more) from power lines and high-voltage lines to minimize the effect of inductive noise. Shielded cables should preferably be used. In this case, the shield braids should be earthed at one point.
- If a large noise is generated from the power supply, provide an isolating transformer and use a noise filter.
- Install the instrument paying attention to prevent foreign matters such as scraps, electric wire chips, and iron powder from entering in the instrument.

- Do not use the wires other than the specified compensation conducting wires for the thermocouple input connection. Otherwise improper indication or malfunction may result.
- Use a wiring cable with low resistance and with small resistance difference among the three wires for the resistance bulb input connection. Otherwise improper indication or malfunction may result.

2.4 Cautions in Operation

- Check every six months that the terminal screws and mounting screws are securely fastened. Loose screws may cause fire or malfunction.
- When changing the setting during the operation or forcibly outputting, starting or stopping the instrument, be sure to check that safety is ensured. Improper operation may result in damage or failure of the instrument.
- Be sure to keep the attached terminal cover mounted on the terminal block during the operation. Otherwise electric shock or fire may result.
- Stop using the instrument if it is immersed in water. Otherwise electric leak, electric shock, or fire may result.
- Never use organic solvents such as alcohol or benzene when cleaning this instrument. Do not directly water the main unit. Otherwise deterioration, failure, electric leak, electric shock, or fire may result. When cleaning the main unit, wipe with a dry cloth.
- Dispose the instrument as an industrial waste.
- This product contains a CR Coin Lithium Battery which contains Perchlorate Material-special handling may apply.
See www.dtsc.ca.gov/hazardouswaste/perchlorate

2.5 Handling memory card (Compact Flash)

- For the memory card, use Sandisk's compact flash memory (URL: <http://www.sandisk.com>). A compact flash manufactured by other companies may not be used or cause other problems.
 - 1) Be sure to format the memory card with the PC you use.
Format it as FAT16 or FAT. If it is formatted as NTFS, for example, it cannot be used because the PHF does not recognize it.

- 2) The memory card should be inserted in the proper direction and fixed securely to the slot.
- 3) Don't turn OFF the power or remove the card from the slot while data is being written in or read from the card, or recorded data may be damaged or lost.
- 4) We recommend you to back up the data contained in the card once a month. If the CF card is broken, the important log data contained in CF card will be lost. Be sure to back up the data.
Before using a compact flash card adaptor, check the capacity of the adaptor. If the capacity of the memory card to be formatted is larger than that of the adaptor, do not format the card. If the card is formatted, a display may appear on Windows indicating that formatting is completed, but PHF does not recognize the completion of formatting.
- 5) Compact flash in the capacity range from 8MB to 512MB can be used.
- 6) The data recorded in the compact flash can be re-generated on the PC by using the data viewer (contained in the attached CD-ROM).
If the data is recorded in ASCII format, it can be directly opened in a spreadsheet such as EXCEL. However, large-amount data cannot be opened (about 7MB or larger in the case of 6-point input, and about 4MB or larger in the case of 3-point input).
In those cases, read in data with the data viewer (contained in the attached CD-ROM), and perform CSV conversion to divide the file, which allows the data to be read in.
The data recorded in binary format cannot be directly opened in a spreadsheet such as EXCEL. Be careful not to make the size of a file too large even if a large-capacity CF card is used. (Keep it to 10MB or less.)

For Proper Usage

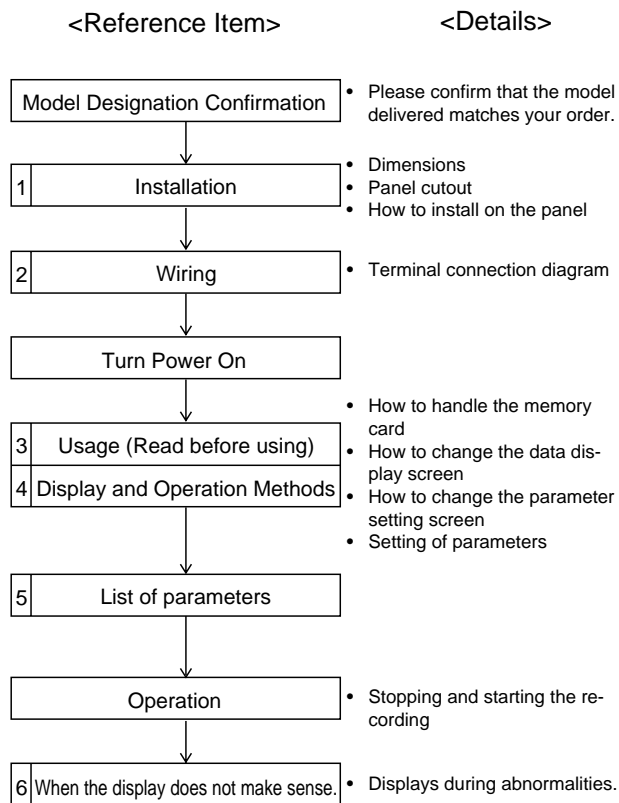

※ Since about 60 minutes is needed until the unit becomes thermally stable, wait for 60 minutes or more after turning the power on before making measurements, etc.

1 Installation

Dimensions/Panel Cutout

(unit : mm)

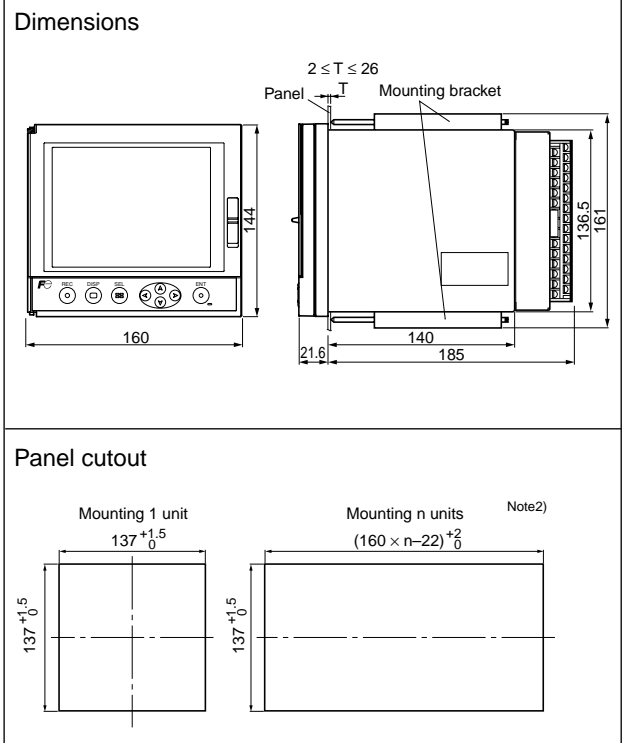

Note1) If other instruments are placed under the recorder unit, provide a space of 100 mm or more from the instrument or floor.

Cautions on wiring

- Use crimped terminals matched to the screw size. Tightening torque should be about 0.2 N·m.
- Do not connect anything to terminals not used.

	AC power source
	Protective grounding
	Power ON
	Power OFF
	Double insulation
	Electric shock hazard

2 Wiring

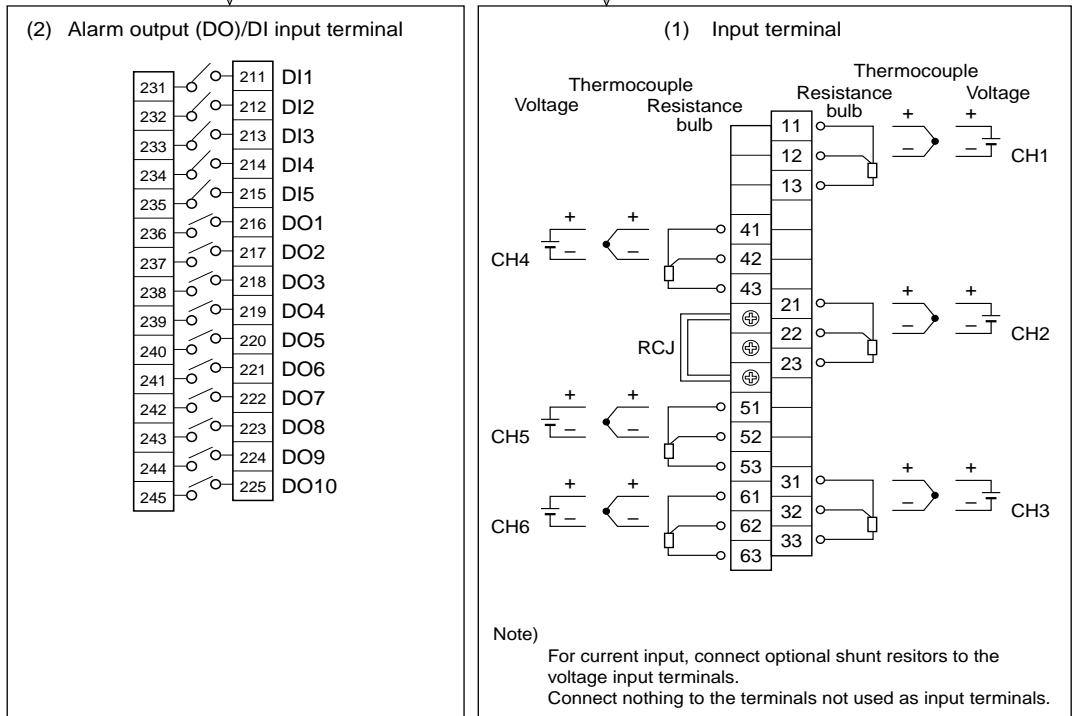
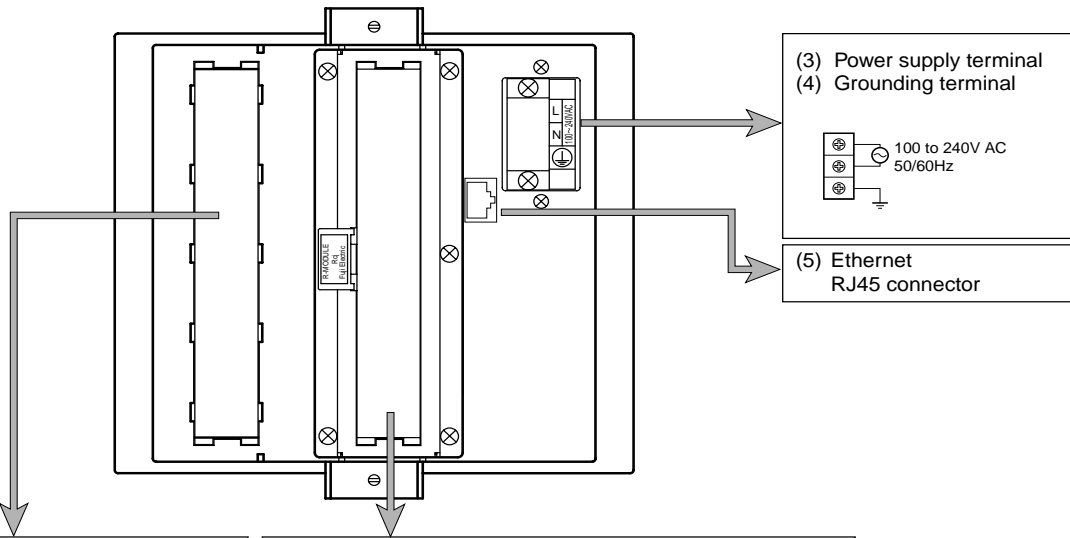

- (1) Input terminal : Connect signal cable for each channel.
- (2) Alarm (DO)/DI (External control unit):
Connect the output of alarm signals and the input of DI (external control) signals.
(for alarm [DO] 1 to 10 and DI [external control] 1 to 5)
- (3) Power terminal : Connect power cable to L/N terminals. Power source to be connected should be free from noise.
- (4) Grounding terminal : Connect grounding cable to "G" terminal (Class-D, 100Ω or less).
- (5) Ethernet terminal

3 Operation Parts and Their Functions

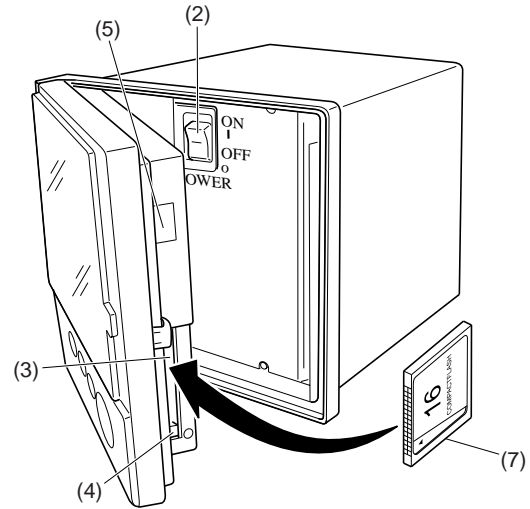
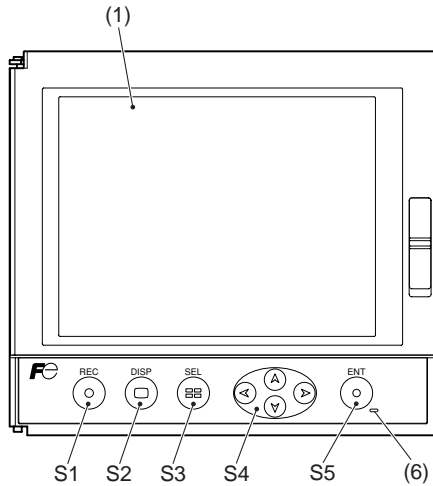

Name	Function
(1) Display unit	Allows the Real time trend screen, Bar Graph Display screen, Digital Display screen, Historical trend screen and other various Parameter Set screens to be displayed.
(2) Power switch	Used to turn the power ON or OFF.
(3) Memory card slot	Used for inserting the memory card. Insert the card straight into the slot as shown in upper right figure. Be careful not to forcibly press the card if it is inserted obliquely. Otherwise the pin on the PHF may be damaged.
(4) Memory card ejection button	To remove the memory card from the slot, press this button. Caution
(5) Connector to parameter loader	When changing parameters by using a loader, connect the exclusive cable (optional cable: Type; PHZP1801 or USB cable [USB (A) plug – USB (mini B) plug]) to the connector.
(6) Status indicator lamp	Displays power ON/OFF, LCD (screen) ON/OFF, and recording status. Lamp ON (lighting) : Power: ON, LCD: ON (recording in progress or suspended) Lamp blinking (ON for 2 seconds / OFF for 2 seconds) : Power: ON, LCD: OFF (recording in progress) Lamp blinking (ON for 1 second / OFF for 1 second) : Power: ON, LCD: OFF (recording suspended) Lamp OFF (extinction) : Power: OFF
(7) Memory card	For the memory card, use Sandisk's compact flash memory (URL: http://www.sandisk.com). Other memory cards may cause trouble to the recorder.

Caution

- Do not remove the memory card during recording. Refer to the another Manual in the CD-ROM "Removing memory card (compact flash)" for the removal of the memory card while recording is in progress.
- After inserting the memory card into the slot, don't remove the card until the recorder can acknowledge it.
- Be careful with static electricity when removing the memory card.

Name	Function
S1 REC key	<ul style="list-style-type: none"> Used to start or stop recording. Pressing once starts recording, and pressing once again stops recording.
S2 DISP key	<ul style="list-style-type: none"> Used to switch displayed contents. Every time it is pressed, the display is switched in the following order: (1)→(2)→(3)→(4)→(5)→(6) and back to (1). (1) Real time trend display (2) Key guidance display (3) Bar graph display (4) Digital display. (5) Event summary display (6) Ethernet log display Used to switch the parameter setting screen to the data display screen.
S3 SEL key	<ul style="list-style-type: none"> Used to switch from the data display screen to the parameter setting screen. Pressing the key on the parameter setting screen switches to the screen one step up. Note, however, that pressing the key on the menu screen does not change screens.
S4 Cursor key	<ol style="list-style-type: none"> Used to select setting items. Used to increase or decrease numerical values. Pressing the ▼ key on the real time trend displays the historical trend screen (*1). At this time, the window can be scrolled using the cursor key. <p>*1: The screen in the past of the data currently recorded</p>
S5 ENT key	<ol style="list-style-type: none"> Used for selection on the setting screen or registration of the set data. If the key is pressed while the scales are displayed on the real time trend display screen, historical trend display screen (*1), or recorded data display screen, the channels for which scales are to be displayed can be switched. (Scale of ch1 → scale of ch2 → → scale of ch6 → scale of ch1 → scale of ch2.....) <p>*1: The screen in the past of the data currently recorded</p>

4 Display and Operation Procedure

Data display screens

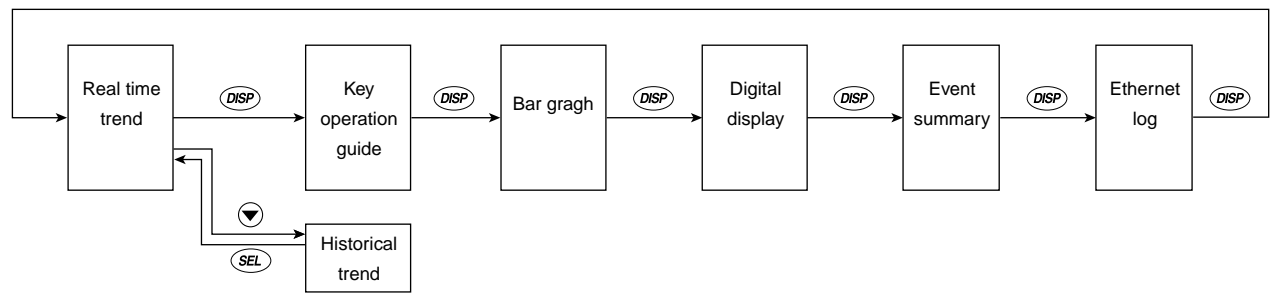

Go to Real time trend

Go to Parameter setting screen.

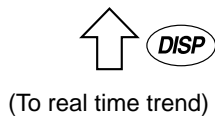

SEL

Parameter setting

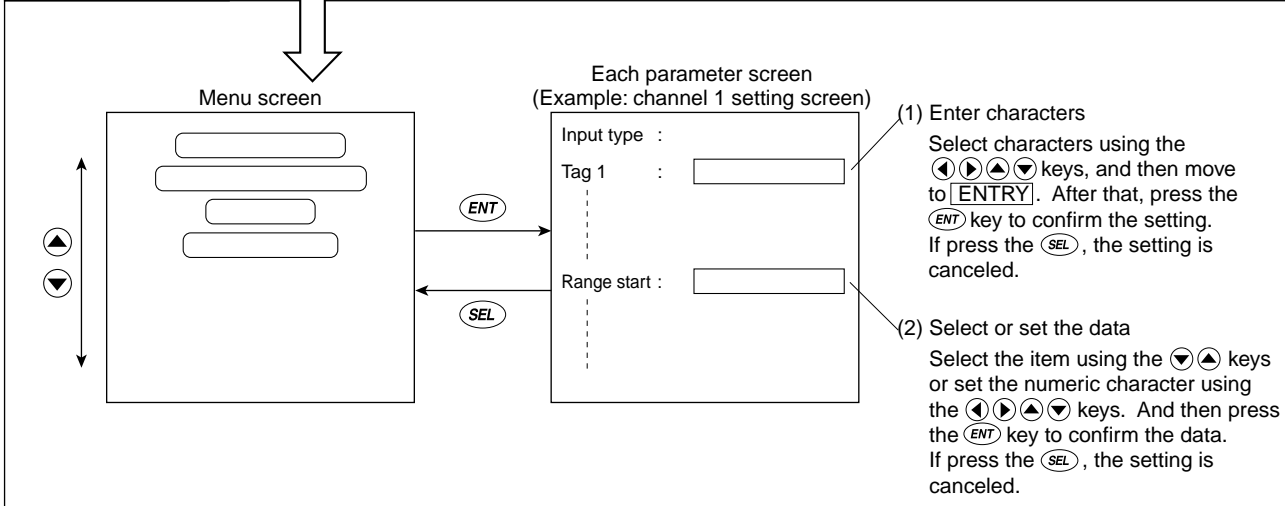

5 List of Parameters

Parameter name	Setting at delivery (Default value)	Setting range	Remarks	
Basic setting	Display refresh cycle : 1 second	1 second to 12 hours	*1 LCD keeps turning on when set "0".	
	Alarm hysteresis : 0.2%	From 0.00 to 100.00%		
	Alarm latch : OFF	OFF, ON		
	LCD lights out time : 0 *1	0 to 60 minutes		
	DO output at memory FULL: None	None, DO1 to DO10		
	DO output at battery END: None	None, DO1 to DO10		
	File division cycle : No division	No division, 1 hour, 1 day, 1 week, 1 month		
	Date format : yyyy/mm/dd	yyyy/mm/dd, dd/mm/yyyy, dd-mmm-yy, mm/dd/yyyy, mmm-dd-yy		
	MODBUS station No. : 1	0 to 255		
	Front communication : ON	OFF, ON		
	Record data format : ASCII	ASCII, Binary		
	Time setting : —	—		
	Register data :	—		
Channel setting	Input type: K-Type TC (K thermocouple)	Skip, K, E, J, T, R, S, B, N, W, L, U, PN thermocouple, Pt100, JPt100, Ni100, Cu50, Pt50, 50mV, 500mV, 1-5V and 0-5V range	Select an input type from the same group for channels 4 and 5.	
	TAG1: TAG ** (**: channel No.)	Up to 8 characters		
	TAG2 : Blank	Up to 8 characters		
	Unit : °C	°C, °F, Engineering unit in case of voltage input		
	Input range (range start/end): 0 to 1200	Engineering value		
	Decimal point position : ****.*			
	Input filter : 3 seconds	0 to 900 seconds (In increments of 1 second)		
	Subtraction channel : None	0 to 6 (No subtraction at 0)		
	PV shift : 0.0	Engineering value -3276.7 to 3276.7		
	PV gain : 100%	0.00 to 327.67%		
	Recording type: Maximum/minimum value recording	Instantaneous value recording, average value recording, maximum/minimum value recording		
	Recording mode : With record	With record/Display only		
	Alarm setting			
	Alarm No. 1 type : OFF	OFF, H, L		
	Set point : 0.0°C	Engineering value		
	DO relay No. : None	DO1 to DO10		
	From alarm No. 2 to No. 4 There are the same items above.			
Display setting	Display configuration: No. 1 to 6 = ch1 to 6	No.1 to 6, Each provided with ch1 to 6		
Original unit definition	Unit : Blank	Up to 7 characters		
DI setting	DI function: Function invalid	Function invalid, Rec start/Rec stop, LCD ON		

Parameter name	Setting at delivery (Default value)	Setting range	Remarks
Ethernet setting	IP address : 0.0.0.0	0 to 255	
	Subnet mask : 0.0.0.0	0 to 255	
	Default gateway : 0.0.0.0	0 to 255	
	FTP server function : OFF	OFF, ON	
	FTP access control : OFF	OFF, ON	
	Web server function : OFF	OFF, ON	
	E-mail function : OFF	OFF, ON	
E-mail setting	MODBUS TCP/IP : OFF	OFF, ON	
	SMTP IP address : 0.0.0.0	0 to 255	
	Sender's mail Address : Blank	Up to 64 characters	
	Sender's mail Name : Blank	Up to 32 characters	
E-mail trigger setting	Receiver's mail Address 1 to 8 : Blank	Up to 64 characters	
	Trigger timing : None	None, DI ON, DI OFF, Alarm ON, Alarm OFF, Warning, Timer cycle	
	Alarm Channel : 1	Channel 1 to 6	
	Alarm No. : 1	1 to 4	
	Title : Blank	Up to 32 characters	
	Text1, 2 : Blank	Up to 32 characters	
	PV value affixation : OFF	OFF, ON	
User account setting	Receiver's add No. : 1	1 to 8	
	Mail send test : —		
	User name : Blank	Up to 16 characters	
Config and record password	Password : Blank	Up to 8 characters	
	User Level : administrator	Administrator, guest	
Config and record password	Password : 0000	0000 to 9999	
	Record Password : 0000	0000 to 9999	

6 Troubleshooting

Error indications

This recorder is provided with an error display function. Modify the abnormal conditions as soon as an error display appears. Make sure to turn off the power before checking the wire connection to modify the abnormal conditions. Otherwise electric shock or a serious accident may result.

Display	Cause
OVER	Displayed when the measurement signal inputs exceeding the settable recording range (Table 1).
UNDER	Displayed when the measurement signal inputs lower than the settable recording range.
ERROR	Displayed in the following cases with 50mV, 500mV, and 5V input. 1) When the measurement signal inputs exceeding OVER. 2) When the measurement signal inputs lower than UNDER.
BURNOUT	Displayed in the following cases with TC and PT input. 1) When a break or disconnection of a cable occurs within the sensor 2) When the measurement signal inputs exceeding OVER. 3) When the measurement signal inputs lower than UNDER.

7 Specifications

Specification

Power voltage	: 100 to 240 V AC ($\pm 10\%$), 50/60 Hz
Power consumption (VA)	: 42 VA max. (240 V AC)
Input measurement range	: Range where input reading accuracy is assured.
Record range	: Settable recording range. (See Table 1.)
Input circuit	: Insulated between all channels (functional insulation).
Measurement cycle	: 100 msec
Record cycle	: 1 sec to 12 hours/one time
Record type	: Select from max.-min. value, instantaneous value, or average value.
Data storage cycle	: 1 min. (when record cycle is less than 1 min.) or synchronized with record cycle (when record cycle is more than 2 min.).
Record media	: Compact Flash (by Sandisk), 512MB max. Only FAT16 or FAT is supported.
Data format	: Select from ASCII or binary. Refer to *1 for usage size of measured data.
Alarm type	: Upper limit alarm, lower limit alarm
Alarm Output (relay)	: (DO1) 150Vac/3A, 30Vdc/3A : (DO2 to10) 240Vac/3A, 30Vdc/3A
Digital input	: No-voltage contact input.
Operating environment	: Indoor
Operating temperature	: 0 to 50°C (without Ethernet function) : 0 to 40°C (with Ethernet function) Note) When ambient temperature is 30°C or over, the whole screen may look whitish, but it is not a failure.
Operating humidity	: 20 to 80% RH (No condensation allowed.)
Storage temperature	: -10 to 60°C
Storage humidity	: 5 to 90% RH (No condensation allowed.)
Installation category	: II
Pollution degree	: 2
Operating altitude	: 2000m max.
Calibration	: Calibrate at least once a year in order to maintain high measurement accuracy. For calibration, refer to the instruction manual in the CD-ROM, or contact us.
Ethernet - protocol	: 10 Base-T : Web (server) : FTP (server) : SMTP (client) : MODBUS-TCP (slave)

*1 Usage size of measurement data

Usage size for each sampling is as follows:

ASCII (max.-min. record)

Time : 21 bytes

Measurement data: 16 bytes \times number of input points

From the above, if the number of input point is 6ch,
 $21 + 16 \times 6 = 117$ bytes

ASCII (instantaneous or average value)

Time : 21 bytes

Measurement data: 8 bytes \times number of input points

From the above, if the number of input point is 6ch,
 $21 + 8 \times 6 = 69$ bytes

Binary (max.-min. record)

Time : 4 bytes

Measurement data: 4 bytes \times number of input points

From the above, if the number of input point is 6ch,
 $4 + 4 \times 6 = 28$ bytes

Binary (instantaneous or average value)

Time : 4 bytes

Measurement data: 2 bytes \times number of input points

From the above, if the number of input point is 96ch,
 $4 + 2 \times 6 = 16$ bytes

8 Code Symbols

Digit	Item	Specifications	1	2	3	4	5	6	7	8	9	10	11	12	13
4	Number of input points	3-point input 6-point input	P	H	F	*	1	B	1	1	-	E	1	*	V
9	Display	English													
11	Alarm (relay) output/DI input board	Without With													
12	Communication Ethernet	Without With													

9 Maintenance

Recommended parts replacement cycle

- Front panel : 5 years (degradation of brightness of LCD back light.
Pickup repair: including packing and battery)
- Lithium battery : 5 years (pickup repair)
- Fuse (external) : 2 years (for preventive maintenance)
: rating: 250V AC 1A
- Memory card : 6 months
: Back up the data more frequently than 6 months.

Table 1 Display Range Set Range

Type		Input range	Record range set range
Thermocouple	B	400 to 1760°C	370.0 to 1790.0°C
	R	0 to 1760°C	- 30.0 to 1790.0°C
	S	0 to 1760°C	- 30.0 to 1790.0°C
	K	-200 to 1370°C	-230.0 to 1400.0°C
	E	-200 to 800°C	-230.0 to 830.0°C
	J	-200 to 1100°C	-230.0 to 1130.0°C
	T	-200 to 400°C	-230.0 to 430.0°C
	N	0 to 1300°C	- 30.0 to 1330.0°C
	W	0 to 1760°C	- 30.0 to 1790.0°C
	L	-200 to 900°C	-230.0 to 930.0°C
	U	-200 to 400°C	-230.0 to 430.0°C
PN	0 to 1300°C	- 30.0 to 1330.0°C	
Resistance bulb	JPt100	-200 to 600°C	-230.0 to 630.0°C
	Pt100	-200 to 600°C	-230.0 to 630.0°C
	Ni100	-60 to 180°C	-90.0 to 210.0°C
	Pt50	-200 to 600°C	-230.0 to 630.0°C
	Cu50	-50 to 200°C	-80.0 to 230.0°C
DC voltage		0 to + 50mV	- 10.00 to + 55.00mV
		0 to +500mV	- 10.0 to + 550.0mV
		+ 1 to + 5V	+ 0.500 to + 5.500V
		0 to + 5V	- 0.100 to + 5.500V