

Model 122 Regulators

Installation and Maintenance Instructions

Introduction

The Model 122 Regulator illustrates a combination of capacity, performance and value. The streamline body passages provide large capacity. Internal control is standard with external control also available. The 122 has a fast speed of response, yet is stable in operation. Soft seats ensure positive tight shutoff. Orifices are replaceable. Springs are color coded.

And it is also available as a zero governor or atmospheric regulator, a differential regulator and a relief valve or back-pressure regulator.

Installation

1. Examine the regulator for shipping damage.
2. Check nameplate data. Be sure regulator conforms with what was ordered.
3. Inside of regulator and piping must be clean and free of dirt. Remove all dirt and debris before installing regulator. Failure to remove dirt/debris could result in regulator damage or trouble.
4. Remove all shipping screens and covers from the regulator. Do not let dirt get inside the regulator.
5. Install the regulator.

Make sure the inlet and outlet are correctly connected. High pressure connects to the inlet. The flow arrow must point downstream.

6. Screwed connections must conform with good piping practice free of excess thread engagement per ANSI B2.1. Apply pipe joint compound to male threads only.
7. The model 122 regulator is usually installed right side-up as shown on the Typical installation drawing (See Page 3). It may, however, be installed upside down. Although, when inverted it may be necessary to readjust the set-point.

Caution: Do not install sideways. The diaphragm should be horizontal.

8. On indoor installations requiring venting outdoors, run the vent piping as short and indirect as possible with minimum bends and elbows. Use the same size pipe as the vent connections on the regulator. With natural gas, or any other hazardous gas, vent to a safe place outdoors in case gas should accidentally be discharged. Screen and protect the outdoor opening to guard against water, ice, dirt, debris or insects.

This item only applies to regulators requiring a control line. It does not apply to 122 Regulators with internal control. Install the control line. Connect it into the outlet piping at least 5 pipe diameters downstream from the regulator.

Caution:

- a. On backpressure regulators and relief valves with external control, the control line connects into the **inlet** piping.
- b. Do not install any automatic shutoff device that closes completely between the regulator and the control line connection into the piping.

To avoid excessive turbulence, the connection should be clean and smooth on the inside and be located in straight pipe clear of valves and fittings. Keep the inside of the control line clean and protect it from corrosion. Pitch it away from the regulator and avoid moisture pockets. It must be strong (1/4" or larger steel tubing or pipe is preferred). It must be well protected against breakage (remember, regulators open wide if the control breaks).

9. Make sure the regulator is correctly connected and adequately supported and pipe joints are tight.

Start-Up

- A. The inlet and outlet shutoff valves should both be closed. If a by-pass is used, the bypass valve should also be closed.
- B. Note the set-point (set-point is the outlet pressure the regulator is adjusted to deliver). Regulator is factory adjusted to the set-point specified on the order.

Caution:

This caution applies where the piping downstream of the outlet shutoff valve is pressurized. That pressure must not exceed the regulator set-point by more than 2 psi (see "Maximum Emergency Pressures", Page 11).

- C. Slowly and carefully open the inlet shutoff valve just enough to allow **inlet pressure** to build up slowly in the regulator until it is fully pressurized.

Caution:

During start-up a pressure gauge must be used on the regulator **outlet** pressure and carefully watched. While **inlet** pressure builds up, **outlet** pressure must not exceed set-point by more than 1 psi. If **outlet** pressure begins to exceed set-point by more than 1 psi, close the **inlet** shutoff valve. This indicates the regulator is not closing properly. Check and make necessary corrections before proceeding with start-up.

If regulator **outlet** pressure exceeds set-point by more than 2 psi, refer to "Maximum Emergency Pressures", Page 11 for instructions.

- D. Check installation for leaks.
- E. Slowly open the outlet shutoff valve to allow a small flow (approximately 250 SCFH). Make sure the flow of gas does not create a hazard.

NOTE: If piping downstream of outlet shutoff valve is pressurized, see "Caution" under B.
- F. With gas flowing, check for correct inlet and outlet pressures. It may be necessary to further open the inlet shutoff valve to maintain full inlet pressure.
- G. Make sure the regulator closes tight (tight lock-up). To do this, reduce flow to zero by slowly closing the outlet shutoff valve. Outlet pressure should not exceed set-point by more than 3" w.c.
- H. Fully open inlet and outlet shutoff valves slowly and carefully. Watch pressure gauges.
- I. Complete start-up by making sure there are no leaks.

NOTE

- Do not exceed the regulator’s pressure ratings. The regulator outlet has a lower pressure rating than the inlet. Do not expose the regulator outlet or control line to inlet pressure.

Regulator with external control may be used as an upstream monitor or upstream regulator in a monitor set. However, if a 122 Internal Control is converted to External Control, the internal control opening must be closed off and the control line must connect into the outlet piping downstream of the regulator.

- If the regulator is to be moved to another location, make sure its construction is compatible with the pressure and flow conditions.

Temperature Limits

The Model 122 Regulator can be used for flowing temperatures from -20°F. to 150°F.

Buried Service

The Model 122 Regulator is not recommended for buried service.

Set-Point Adjustment (See Pages 5–10)

The 122 is factory as specified on the order. To change the set-point, readjust as follows:

1. Remove top cap 1.
2. Adjust set-point with adjustment button 3 or 6. Turn clockwise to increase and counterclockwise to decrease the outlet pressure.

NOTE:

- a. Only make this adjustment when gas is actually flowing through the regulator. The flow should be small (approximately 250 SCFH). Do not adjust when the regulator is closed and there is no flow.
- b. Do not increase the set-point beyond the upper limit of the outlet pressure range for the spring 9 (refer to spring tables, Page 3).
- c. Always check the outlet pressure with a pressure gauge while adjusting the set-point.

3. When adjustment is complete, replace top cap 1. Screw it securely into place. Leaving it off could cause unstable regulator operation.

 **CAUTION**

It is the user’s responsibility to assure regulator vents and/or vent lines exhaust to a non-hazardous location away from ANY POTENTIAL sources of ignition. Where vent lines are used, it is the user’s responsibility to assure that each regulator is individually vented and that common vent lines ARE NOT used.

To Change Spring (See Pages 5–10)

The outlet pressure ranges of the spring 9 are given in the tables on Page 3. To change the spring:

1. Remove top cap 1.
2. Unscrew and remove adjustment button 3 or 6 by turning counterclockwise, and remove spring 9.
3. Insert new spring. Make sure it is positioned correctly at the bottom before replacing adjustment button 3 or 6.
4. Adjust for the desired outlet pressure per previous section “Set-Point Adjustment.”
5. When adjustment is complete, replace top cap 1. Screw it securely into place. Leaving it off could result in unstable regulator operation.
6. New spring range should be marked on regulator. If old spring range appears on regulator, it should be removed.

 **CAUTION**

The diaphragm case vent must be positioned to protect against flooding, drain water, ice formation, traffic, tampering, etc. The vent must be protected against nest building animals, bees, insects, etc. to minimize the chances of foreign material collecting in the vent side of the regulator diaphragm.

Shutdown

NOTE: Before working on the regulator, read the next section “General Servicing Instructions” and the applicable servicing instructions.

To shutdown and take the regulator out of service:

1. Carefully close the inlet stop valve.
2. Close the outlet stop valve.

 **CAUTION**

Turn gas on very slowly. If an outlet stop valve is used, it should be opened first. Do not overload diaphragm with a sudden surge of inlet pressure. Monitor the outlet pressure during start-up to prevent an outlet pressure overload.

General Servicing Instructions

- A. Before any disassembly of the regulator make sure it is completely depressured. Pressure must be fully released from the inlet, the outlet and the control line connection. Failure to adequately depressure could result in serious personal injury.
- B. Carefully note the location and position of all disassembled parts to be certain reassembly is correct. Inspect each part carefully and replace any that are worn or damaged or otherwise unsatisfactory.
- C. Upon completion of servicing, make certain the regulator installation is entirely free of leaks.

 **CAUTION**

Regulators are pressure control devices with numerous moving parts subject to wear that is dependent upon particular operating conditions. To ensure continuous satisfactory operation, adhere to periodic inspection schedule with the frequency of inspection determined by the severity of service and applicable laws and regulations.

Typical Installation

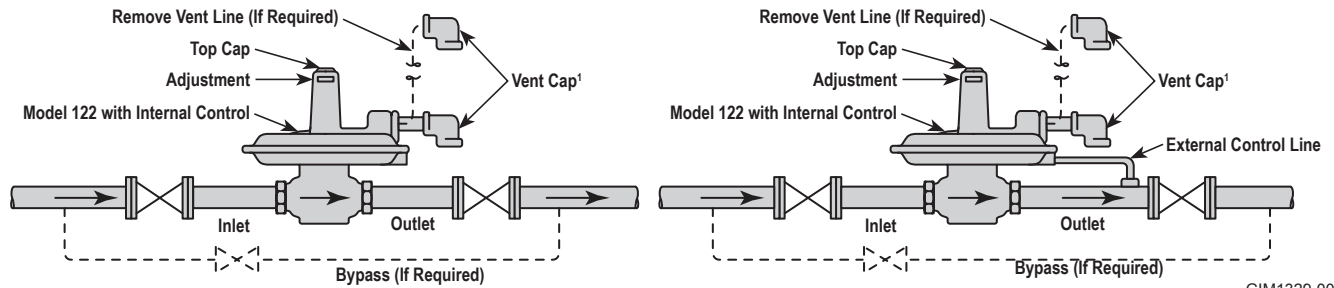

¹ Screened VENT CAP (Model 137) with screen-facing downwards is recommended to minimize the possibility of water or other foreign matter entering regulator vent.

GIM1329-005

Pressure Ranges and Springs

Standard Regulator

Size	Outlet Pressure Range	Spring Color	Spring Part Number	Maximum Inlet Pressure	Nominal Diaphragm Size
1" and 1¼" Model 122-8	1½" w.c. to 3½" w.c.	Blue-Black	143-82-021-01 (main spring)	15 psi	8"
	1½" w.c. to 12" w.c.	Black	121-41-021-00 (counterspring)		
		Green-Black	143-82-021-02 (main spring)		
	3½" w.c. to 6½" w.c. ①	Black	121-41-021-00 (counterspring)		
		Red-Black	143-82-021-00		
	5" w.c. to 8½" w.c. ①	Blue-Black	143-82-021-01		
	6" w.c. to 14" w.c. ①	Green-Black	143-82-021-02		
	12" w.c. to 28" w.c. ①	Green	143-16-021-05		
1" psi to 2 psi	Orange	143-16-021-06			
½", 2" and 2½" Model 122-12	1½" w.c. to 3½" w.c.	Red	143-16-021-03 (main spring)	15 psi	12"
	1½" w.c. to 12" w.c.	Red-Black	121-10-021-50 (counterspring)		
		Maroon	121-42-021-00 (main spring)		
	3½" w.c. to 6½" w.c. ②	Red-Black	121-10-021-50 (counterspring)		
		Red	143-16-021-03		
	5" w.c. to 8½" w.c. ②	Blue	143-16-021-04		
	6" w.c. to 14" w.c. ②	Green	143-16-021-05		
	12" w.c. to 28" w.c. ②	Orange	143-16-021-06		
	1" psi to 2 psi	Black	143-16-021-07		
	½" psi to 2 psi	Cadmium	143-16-021-08		

① ② These Springs are also used on Model 122 Differential Regulators (see below).

Atmospheric Regulator or Zero Governor

Size	Outlet Pressure Range	Spring Part Number and Color	Maximum Inlet Pressure	Nominal Diaphragm Size
1" and 1¼" Model 122-8	1" w.c vacuum (-1" w.c.) to + 1½" w.c.	143-82-021-00 Red-Black (main spring)	15 psi	8"
		121-41-021-00 Black (counter spring)		
½", 2" and 2½" Model 122-12	1" w.c vacuum (-1" w.c.) to + 1½" w.c.	143-82-021-00 Red-Black (main spring)	15 psi	12"
		121-10-021-50 Red-Black (counter spring)		

Differential Regulator

Use **STANDARD REGULATOR** springs. **Outer Pressure Range, Spring Color and Spring Part Number are the same.** Use ① springs for 1" and 1¼" Model 122-8 Differential Regulators and ② springs for ½", 2" and 2½" Model 122-12 Differential

Regulators. For all sizes (¾" through 2½") the Maximum Diaphragm Pressure Differential is 1 psi, the Maximum Pressure for the Body is 15 psi and the Maximum Pressure for the Diaphragm Case is 5 psi.

Back Pressure Regulator or Relief Valve

Size	Relief or Back Pressure Range	Spring Color	Part Number	Maximum Body Inlet Pressure	Nominal Diaphragm Size
1" and 1¼" Model 122-8	3" w.c. to 5½" w.c.	Red-Black	143-82-021-00	10 psi*	8"
	5" w.c. to 7½" w.c.	Blue-Black	143-82-021-01		
	6" w.c. to 13" w.c.	Green-Black	143-82-021-02		
	10" w.c. to 15" w.c.	Blue	143-16-021-04		
	12" w.c. to 25" w.c.	Green	143-16-021-05		
	18" w.c. to 2 psi	Orange	143-16-021-06		
½", 2" and 2½" Model 122-12	3" w.c. to 5 ½" w.c.	Red	143-16-021-03	10 psi*	12"
	5" w.c. to 7" w.c.	Blue	143-16-021-04		
	6" w.c. to 12" w.c.	Green	143-16-021-05		
	12" w.c. to 25" w.c.	Orange	143-16-021-06		
	20" w.c. to ¼ psi	Black	143-16-021-07		

*These pressures apply only to External Control Models (refer to Pages 5, 6, 7 or 9). For **Internal Control Models** the Maximum INLET Pressure is **SET-POINT plus 2 psi**.

1" and 1¼" Model 122-8

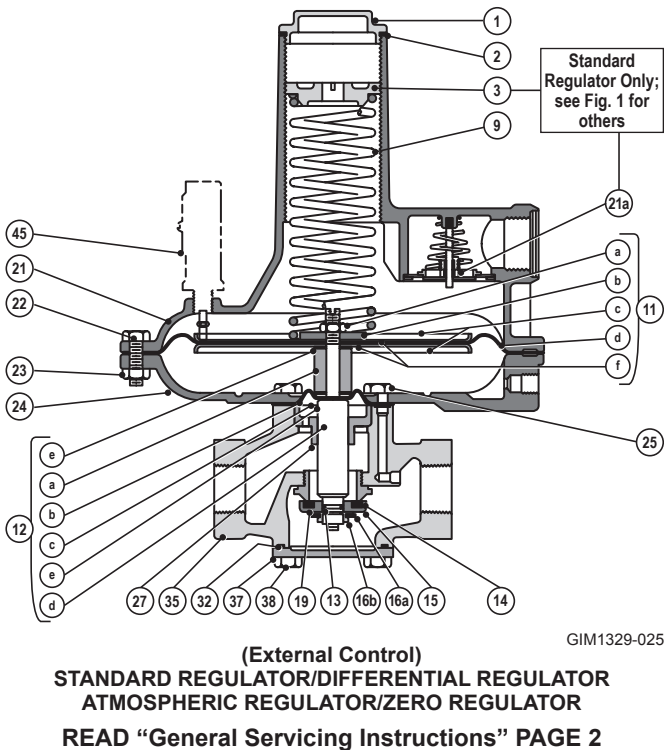
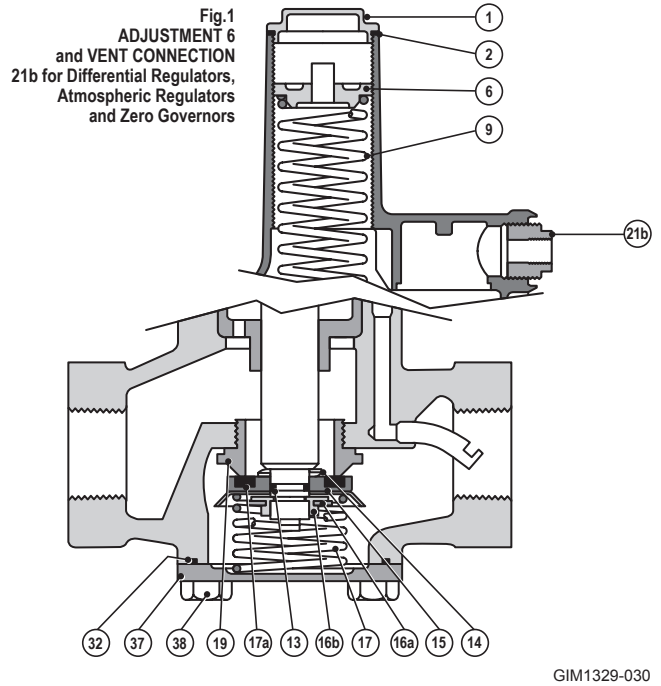
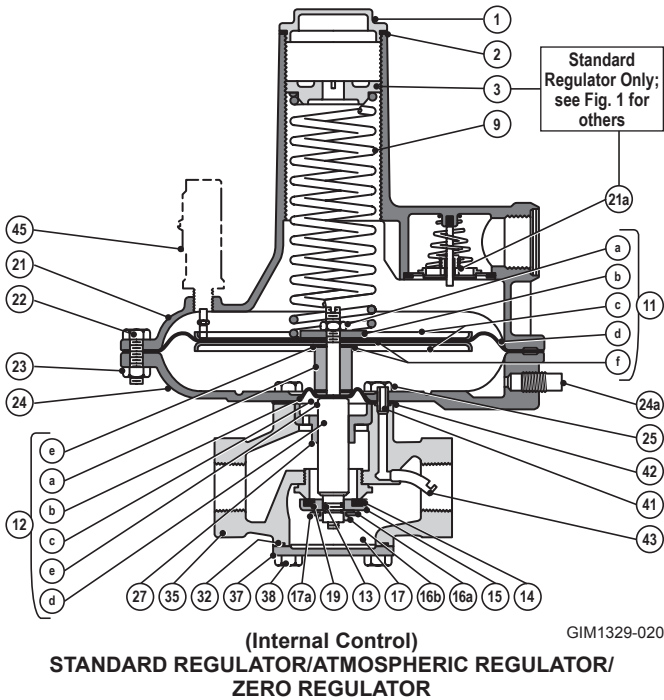

To Service Main Diaphragm (11d)

1. Remove top cap 1, adjustment 3 and 6 and spring 9.
Mark or measure position of adjustment at start. Use this to return adjustment to original setting during reassembly.
2. Remove bolts 22 and upper case 21.
3. On standard Regulators and Differential Regulators, remove bolts 38 and bottom plate 37. Hold valve 15 in upward position for remaining work.
4. Use a screwdriver in slot in top end of stem 12d or 12t to prevent stem from turning and loosen and remove nut 11a.
5. Disassemble diaphragm assembly 11.
6. When reassembling, use screwdriver per step 4 above to prevent stem 12b or 12t from turning while firmly tightening nut 11a. Excessive turning of stem could strain or damage seal diaphragm 12b.
7. Rim bolts 22 should be first made finger tight. Next, insert spring 9 and compress it slightly with adjustment 3 or 6, just enough to force diaphragm assembly 11 fully downwards. Then tighten screws a little at a time until all are firm and secure. There must be no leakage around the rim, but diaphragm 11d must not be crushed, twisted or pinched.

To Service Valve (15)

1. Remove bolts 38 and bottom plate 37.
On Back Pressure Regulators and Relief Valves, remove diaphragm assembly per section "To Service Main Diaphragm (11d)", remove bolts 25 and lower case 24, and remove assemblies 11 and 12 intact and bushing 27.
2. Remove retaining ring 16a. Use Truarc 0200 pliers, Sensus Part Number 1190646.
3. Remove both halves of valve holder 16b and remove valve 15.
4. Reassemble.

To Service Orifice (19 or 20)

1. Remove bolts 38 and bottom cap 37.
2. For orifice 19, remove retaining ring 16a (use Truarc 0200 pliers, Sensus Part No. 1190646), remove split valve holder 16b and remove valve 15.
3. For orifice 20, remove top cap 1 and adjustment 3, and remove spring 9. Mark or measure the position of adjustment 3 beforehand and return it to the same place at reassembly.
4. Unscrew orifice 19 or 20 using 1½" hex socket wrench. When replacing orifice, use a moderate amount of pipe joint compound on orifice threads.

1" and 1¼" Model 122-8

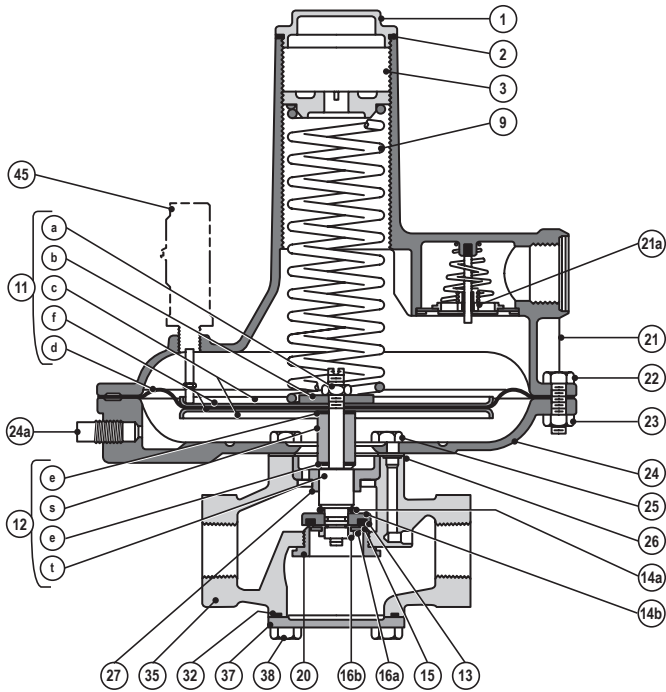

GIM1329-035

(Internal Control)
BACK PRESSURE REGULATOR RELIEF VALVE

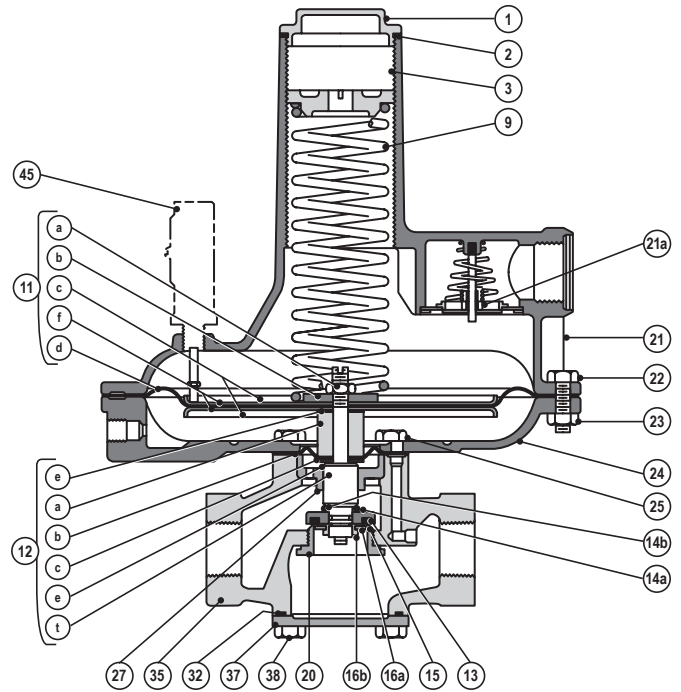

GIM1329-040

(External Control)
BACK PRESSURE REGULATOR RELIEF VALVE

To Service Seal Diaphragm (12b)

1. Disassemble diaphragm assembly per section "To Service Main Diaphragm (11d)".
2. Remove bolts 25 and lower diaphragm case 24.
3. Remove seal washer 12e, spacer 12a and seal diaphragm 12b.
4. During assembly, use screwdriver in slot in top end of stem 12d or 12t while tightening nut 11a. Diaphragms must not be twisted or strained while regulator reassembly is completed.

To Convert From Internal to External Control

1. Remove seal diaphragm 12b per Section "To Service Seal Diaphragm (12b)" and remove bushing 41. Reinstall seal diaphragm 12b so it covers and blocks the hole for bushing 41, and reassemble.
2. On Back Pressure Regulators and Relief Valves, install washer 12c and seal diaphragm 12b in place of gasket 26, install spacer 12a in place of 12s and reassemble.
3. Remove plug 24a and install external control line.

To Convert From External to Internal Control

1. A new body, ILL. No. 35 (with internal control tube 43), is required for standard, differential and atmospheric regulators and zero governors, installation requires complete disassembly per previous sections except that assemblies 11 and 12 remain intact. Install bushing 41 and O-ring 42.
2. On back pressure regulators and relief valves, add gasket 26 in place of seal diaphragm 12b, add spacer 12s in place of spacer 12a and remove 12c as shown, and reassemble. To disassemble follow section "To Service Seal Diaphragm (12b)".
3. Install plug 24a.

Model 122-8 Condensed Parts List 1" and 1¼"

Illustration Number	Description	Part Number
1	Top Cap	143-16-005-00
2	O-ring	951357
3	Adjustment Button	143-16-009-00
6	Adjustment Button	121-10-309-50
9	Spring, See Tables, Pages 3-4	
11a	Nut	908158
11b	Bottom Spring Button	121-10-022-50
11c	Diaphragm Pan	121-10-017-50
11d	Diaphragm, Buna-N, Std.	121-10-150-50
11f	Grip Washer	121-41-178-00
12a	Spacer	121-41-079-00
12b	Seal Diaphragm, Buna-N, Std.	121-41-064-00
12c	Clamp Washer	121-41-010-00
12d	Stem, Stainless	121-41-016-02
12e	Seal Washer	107-62-358-01
12s	Spacer, Std., Stainless	121-41-079-01
12t	Stem, Stainless	121-41-016-03
13	O-ring, 3/8" x 1/2"	934007

Model 122-8 Condensed Parts List 1" and 1¼"
(Continued)

Illustration Number	Description	Part Number
13	O-ring, Viton, 3/8" x 1/2"	902418
14	Wave Washer	905479
14a	Washer Retainer	121-16-103-50
14b	Spacer Washer, Poly-U, Std.	121-16-102-52
15	Molded Valve, Buna-N, Std.	121-10-311-50
16a	Retaining Ring, (5100-75H)	904447
16b	Valve Holder, Split, Stainless	121-16-130-51
17	Counterspring, See Table, Pages 3-4	
17a	Spring Guide	121-42-018-00
19	Orifice, 1¼" dia., brass, Std.	143-16-023-03
20	Orifice, 1¼" dia., brass, Std.	121-10-023-50
21a	Vent Valve Assy	143-16-526-01
26	Gasket	121-41-063-00
32	Tetraseal (or O-ring), 23/8" x 2½"	904081
41	Bushing	121-41-091-00
42	O-ring, ¼" x 3/8", Buna-N	934005
43	Control Tube	121-41-015-01
45	Travel Indicator	091-00-365-63
	Repair Kit — consisting of Main and Seal Diaphragms, Seal Washers, Molded Valve with Wave Washer and Retaining Ring, Tetraseals and Gaskets: All internal control models except Back Pressure or Relief (Std.)	121-41-598-00
	Back Pressure or Relief with internal control (Std.)	121-41-598-02
	All external control models (Std.)	121-598-01

1½", 2" and 2½" Model 122-12

To Service Valve (15)

1. Remove bolts **38** and bottom plate **37**.
On Back Pressure Regulators and Relief Valves, remove diaphragm assembly per section "To Service Main Diaphragm (11d)", remove bolts **25** and lower case **24**, and remove assemblies **11** and **12** intact and bushing **27**.
2. Remove retaining ring **16a**. Use Truarc 0200 pliers, Sensus Part No.1190646.
3. Remove both halves of valve holder **16b** and remove valve **15**.
4. Reassemble.

To Service Main Diaphragm (11d)

1. Remove top cap **1**, adjustment **3** or **6** and spring **9**. Mark or measure position of adjustment at start. Use this to return adjustment to original setting during reassembly.
2. Remove bolts **22** and upper case **21**.
3. On Standard Regulators and Differential Regulators, remove bolts **38** and bottom plate **37**. Hold valve **15** in upward position for remaining work.
4. Use a screwdriver in slot in top end of stem **12d** or **12t** to prevent stem from turning and loosen and remove nut **11a**.
5. Disassemble diaphragm assembly **11**.
6. When reassembling, use screwdriver per step 4 above to prevent stem **12d** or **12t** from turning while firmly tightening nut **11a**. Excessive turning of stem could strain or damage seal diaphragm **12b**. Emery surface of grip washers **11f** should face against both sides of diaphragm **11d**.
7. Make rim bolts **22** finger-tight. Next, insert spring **9** and compress it slightly with adjustments **3** or **6**, just enough to force diaphragm assembly **11** fully downwards. Then tighten screws **22** carefully and evenly, alternately tightening opposite screws a little at a time until all are firm and secure. There must be no leakage around the rim, but diaphragm **11d** must not be crushed, twisted or pinched.

To Service Orifice (19)

1. Remove bolts **38** and bottom plate **37**.
2. Remove valve **15** per section "To Service Valve (15)". (Does not apply to back Pressure Regulators and Relief Valves.)
3. Remove main diaphragm **11d** per section "To Service Main Diaphragm (11d)", remove bolts **25** and lower case **24**, and remove assembly **12** and bushing **27**.
4. Remove retaining ring **19a**. Use Truarc 0600 pliers, Sensus Part Number 1190648.
5. Remove orifice **19**.
6. On assembly be sure retaining ring **19a** is fully seated in the groove all the way around the orifice.
Also, note the bevel on the inside edge of **19a**. The bevel must face toward the knife-edge of the orifice.

1½", 2" and 2½" Model 122-12

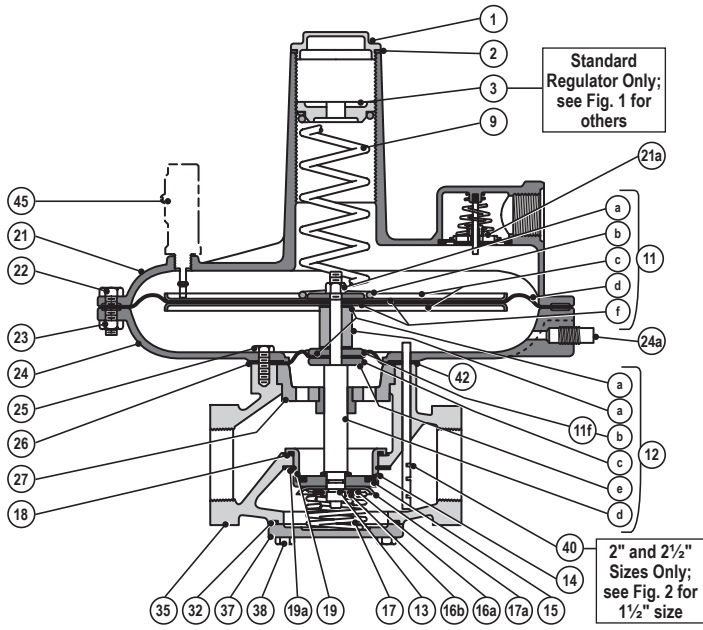

GIM1329-045

(Internal Control)
STANDARD REGULATOR/ATMOSPHERIC REGULATOR/
ZERO REGULATOR

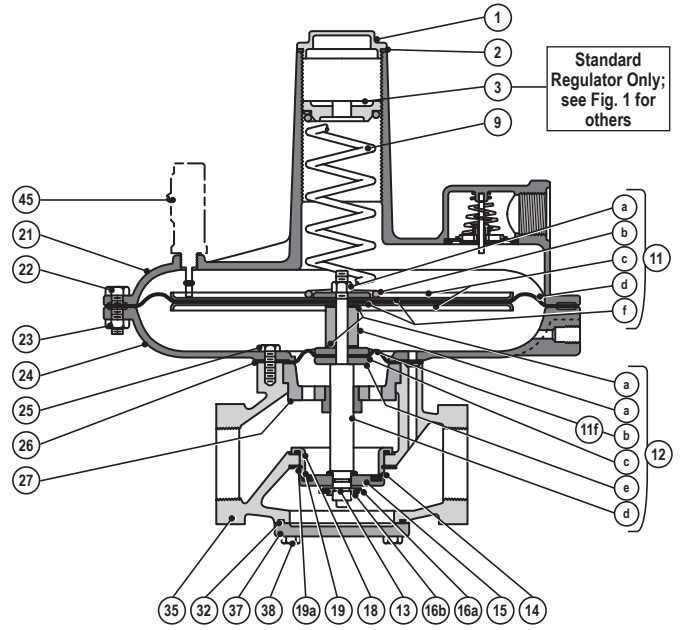

GIM1329-050

(External Control)
STANDARD REGULATOR/DIFFERENTIAL REGULATOR
ATMOSPHERIC REGULATOR/ZERO REGULATOR

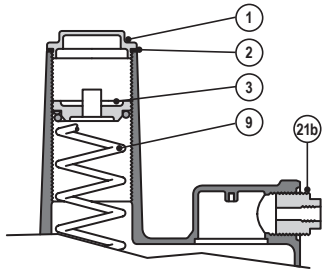

Fig. 1
ADJUSTMENT 6 and
VENT CONNECTION 21b
for Differential Regulators,
Atmospheric Regulators
and Zero Governors

READ "General Servicing Instructions" PAGE 2

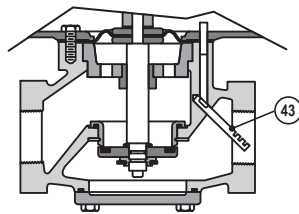
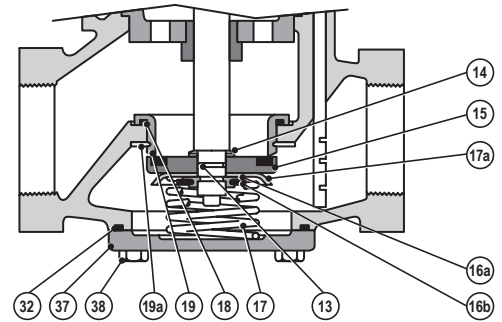

Fig. 2
CONTROL TUBE 43
for 1½" Regulators Only

GIM1329-055



COUNTERSPRING 17 for Atmospheric Regulators and
Zero Governors; also used on Standard Regulators

GIM1329-060

1½", 2" and 2½" Model 122-12

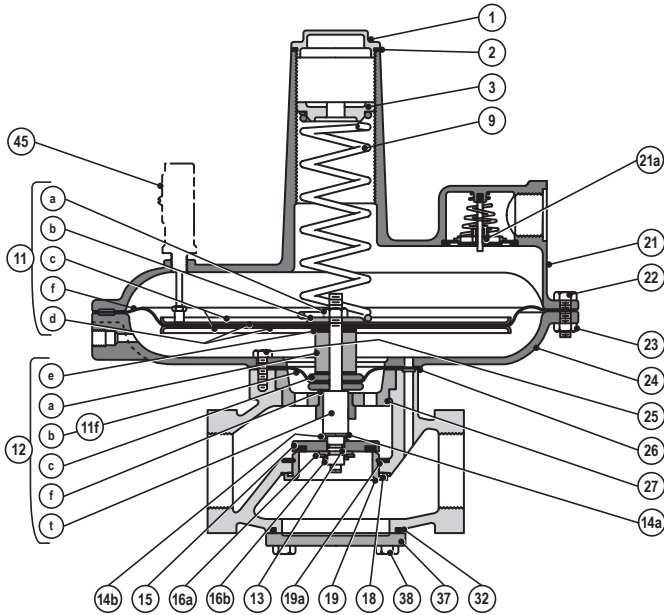

GIM1329-065

**(External Control)
BACK PRESSURE REGULATOR RELIEF VALVE**

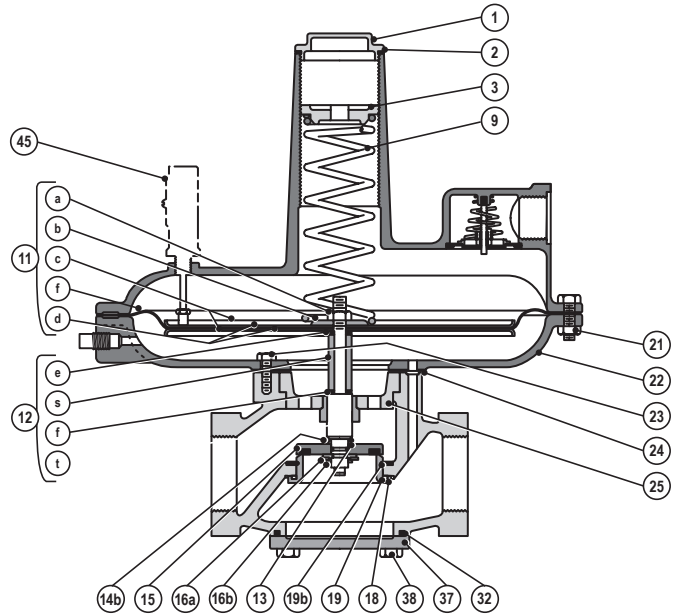

GIM1329-070

**(Internal Control)
BACK PRESSURE REGULATOR RELIEF VALVE**

To Service Seal Diaphragm (12b)

1. Disassemble diaphragm assembly per section "To Service Main Diaphragm (11d)".
2. Remove bolts 25 and lower diaphragm case 24.
3. Remove seal washer 12e, spacer 12a and gasket 26, and remove seal diaphragm 12b.
4. During assembly use screwdriver in slot in top end of stem 12d or 12t while tightening nut 11a. Diaphragms must not be twisted or strained during regulator reassembly.

To Convert from Internal to External Control

1. Remove seal diaphragm 12b per section "To Service Seal Diaphragm (12b)".
On 1½" Model 122 remove bushing 41 (See Fig. 2) and 2" or 2½" Model 122 remove control tube 40.
2. Reinstall seal diaphragm 12b and gasket 26 so they cover and block hole for 40 and 41, and reassemble. On Back Pressure Regulators and Relief Valves, install washers 12c and 12e, spacer 12a, seal diaphragm 12b and two 11f grip washers in place of spacer 12s, and reassemble. Emery surface of grip washers 11f must face against both sides of seal diaphragm 12b. Seal diaphragm 12b and gasket 26 must block the hold for 40 or 41. However, 40 and 41 are not used in the Back Pressure Regulators and Relief Valve.
3. Remove plug 24a and install external control line.

To Convert From External To Internal Control

1. Remove seal diaphragm 12b per section "To Service Seal Diaphragm (12b)."
2. 1½" Model 122 requires a new body with control tube 43 in place as shown in figure 2. Install bushing 41 and O-ring 42 (Figure 2). On 2" and 2½" Model 122 install control tube 40 and O-ring 42. Control tube 40 must be centered and aligned with slots faced downstream as shown.

3. Rotate seal diaphragm 12b and gasket 34 to match 40 or 41 and reassemble.
On Back Pressure regulators and Relief Valves, install spacer 12s in place of spacer 12a, washer 12c and seal diaphragm 12b, and reassemble. Gasket 26 must cover opening for 40 or 41.
4. Install plug 24a.

Condensed Parts List 1½", 2", and 2½" Model 122

Note: For ILL. No's 1, 2, 3, 6, 11a, 11b, 12e, 13, 14a, 14b, 16a, 16b, 17a, 21a, 24a, 41 and 42. See Pages 6-7 CONDENSED PARTS LIST.

Illustration Number	Description	Part Number
9	Spring, See Tables, Pages 3-4	
11a	Hex S. Nut	908158
11b	Diaphragm Plate	121-10-022-50
11c	Diaphragm Pan	121-16-017-50
11d	Diaphragm, Buna-N	121-16-150-50
11f	Grip Washer	121-10-178-50
12a	Spacer	121-42-079-01
12b	Seal Diaphragm, Buna-N	121-42-064-00
12c	Clamp Washer	121-42-010-00
12d	Stem, Std.	121-42-016-00
12d	Stem, Stainless	121-42-016-02
12f	Seal Washer	107-62-358-01
12e	Seal Washer (Emery Cloth)	121-10-179-50
12s	Spacer, Stainless	121-42-079-03

Condensed Parts List 1½", 2", and 2½" Model 122

Note: For ILL. No's 1, 2, 3, 6, 11a, 11b, 12e, 13, 14a, 14b, 16a, 16b, 17a, 21a, 24a, 41 and 42. See Page 6 CONDENSED PARTS LIST. (Continued)

Illustration Number	Description	Part Number
12t	Stem Stainless	121-42-016-03
13	O-ring ¾" x ½"	934007
14	Wave Washer	905479
14a	Valve Washer Ret. (B/P)	121-16-103-50
14b	Valve Spacer Washer (B/P)	121-16-102-52
15	Valve, Buna-N	121-16-311-50
16a	Retaining Ring, (5100-75H)	904447
16b	Valve Holder	121-16-130-50
16b	Valve holder (Stainless Steel)	121-16-130-51
17a	Spring Holder	121-42-018-00
19	Orifice, 2 ⁵ / ₃₂ " dia., Std.	121-16-023-51
19	Orifice, 2 ⁵ / ₃₂ " dia., Stainless	121-16-023-52
26	Gasket	121-42-063-00
27	Valve Stem Bushing	121-42-373-00
32	Tetreseal (or O-ring), 3¼" x 3½"	904078
40	Control Tube	121-42-315-00
43	Control Tube	121-43-315-00
45	Travel Indicator Repair Kit – consisting of Main and Seal Diaphragms, Seal Washers, Molded Valve with Wave Washer and Retaining Ring, Tetraseals and Gaskets: All internal control models except Back Pressure or Relief (Std.) Internal Control Back Pressure and Relief All external control models (Std.)	091-00-365-65 121-42-598-00 121-42-598-02 121-42-598-01

Maximum Emergency Pressures

Be certain the following section is clearly understood before using the information.

The maximum inlet pressure a Model 122 regulator may be subjected to under abnormal conditions without causing internal damage is 20 psi.

The Maximum pressure the diaphragm may be subjected to under abnormal conditions without causing internal damage is set-point plus 2 psi. Set-point is defined as the outlet pressure a regulator is adjusted to deliver.

If either of the above limits is exceeded the regulator must be taken out of service and inspected. Damaged or otherwise unsatisfactory parts must be repaired or replaced before returning the regulator to service.

The maximum pressure that can be safely contained by the diaphragm case on a Model 122 regulator is 5 psi. Safely contained means no leakage as well as no bursting.

Over-pressurization Protection

Protect the downstream piping system and the regulator's low pressure chambers against over-pressurization due to the possible regulator malfunction or failure to achieve complete lockup. The allowable outlet pressure is the lowest of the maximum pressures permitted by federal codes, state codes, Sensus Bulletin RDS-1498, or other applicable standards. The method of protection can be a relief valve, monitor regulator, shutoff device, or similar mechanism.

**Full Open Capacity/
Capacities At Other Pressures**

Capacity of the Model 122 in the wide-open position can be calculated using the following formula and K factors:

- $Q = K\sqrt{P_0(P_1 - P_0)}$
 Q = Full open capacity in SCFH of 0.6 specific gravity natural gas.
 P₀ = **absolute** inlet pressure (psia)
 P₁ = **absolute** outlet pressure (psia)
- K Factors=

1" Model 122-8	K = 1400
1¼" Model 122-8	K = 1750
1½" Model 122-12	K = 2750
2" Model 122-12	K = 4750
2½" Model 122-12	K = 5250

Remember at the above full open capacities the droop is significantly greater than specified in the capacity tables. When checking 122 regulator capacity to provide adequate relief valve capacity, use the above calculated full open capacity. Capacities for pressure reductions not listed in the table can be calculated with the above formula.

Dimensions

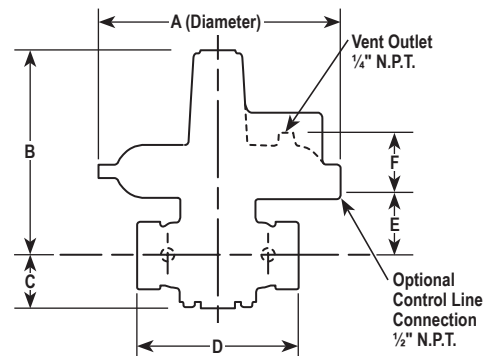

*Taps must be specified when ordering.

GIM1329-075

	A	B	C	D	E	F	Shpg. Wt.
1" NPT	10¼"	11⅝"	1⅞"	5¾"	2½"	3⅙"	15 lbs.
1¼" NPT	10¼"	11⅝"	1⅞"	5¾"	2½"	3⅙"	15 lbs.
1½" NPT	14"	13"	2⅜"	7½"	3 ¹⁵ / ₁₆ "	3 ³ / ₁₆ "	28 lbs.
2" NPT	14"	13"	2⅜"	7½"	3 ¹⁵ / ₁₆ "	3 ³ / ₁₆ "	28 lbs.
2½" NPT	14"	13"	2⅜"	8¼"	3 ¹⁵ / ₁₆ "	3 ³ / ₁₆ "	30 lbs.

Model 122 Regulators

Installation and Maintenance Instructions

Materials of Construction

Body Cast Iron
 Diaphragm Case Die Cast Aluminum Alloy
 Stem Bushing and Plate Plated Steel
 Main and Seal Diaphragms Buna-N with Nylon Fabric Insert
 Orifice Cast Iron (1½", 2" & 2½" Model 122)
 Orifice Brass (¾", 1" & 1¼" Model 122)
 Valve Plated Steel with Molded Buna-N Soft Seat
 Stem Stainless Steel
 Diaphragm Pan, Collars & Washers Plated Steel
 O-rings and Tetra Seals Buna-N
 Adjustment Spring Button Zinc Die Casting (1" through 2¾" Model 122)
 Adjustment Spring Button Thermo-Set Plastic (¾" Model 122)
 Seal Cap Zinc Die Casting (1" through 2½")
 Thermo-Plastic (¾" Model 122)

Other Gases

Model 122 Regulators are mainly used on natural gas. However, they perform equally well on LP gas, nitrogen, dry CO₂, air and others.

Type of Gas	Correction Factor
Air (Specific Gravity 1.0)	0.77
Propane (Specific Gravity 1.53)	0.63
1350 BTU Propane-Air Mix (Specific Gravity 1.20)	0.71
Nitrogen (Specific Gravity 0.97)	0.79
Dry Carbon Dioxide (Specific Gravity 1.52)	0.63

For other non-corrosive gases use the following formula:

$$\text{CORRECTION FACTOR} = \sqrt{\frac{0.60}{\text{Specific gravity of the gas}}}$$

Authorized Distributor:

All products purchased and services performed are subject to Sensus terms of sale, available at either: <http://na.sensus.com/TC/TermsConditions.pdf> or 1-800-METER-IT. Sensus reserves the right to modify these terms and conditions in its own discretion without notice to the customer.

This document is for informational purposes only, and SENSUS MAKES NO EXPRESS WARRANTIES IN THIS DOCUMENT. FURTHERMORE, THERE ARE NO IMPLIED WARRANTIES, INCLUDING WITHOUT LIMITATION, WARRANTIES AS TO FITNESS FOR A PARTICULAR PURPOSE AND MERCHANTABILITY. ANY USE OF THE PRODUCTS NOT SPECIFICALLY PERMITTED HEREIN IS PROHIBITED.

© 2014 Sensus