

# MAXITROL®

## Gas Pressure Regulators for Zero Governor Service

### RZ & 210Z

#### MAXIMUM INLET PRESSURES

RZ Models..... 1 psi (68 mbar)  
 210Z Models.....5 psi (340 mbar)

**GASES:** Suitable for natural, manufactured, mixed gases, liquified petroleum gases and LP gas-air mixtures.

**MOUNTING:** Upright Only

**NOTE:** All Maxitrol regulators should be installed and operated in accordance with Maxitrol's "Safety Warning" Bulletin.

Both the RZ and 210Z series are adaptable for air-gas mixing applications. They may be used for outlet pressures close to atmospheric, from slightly above to slightly below (-1.0" to 1.5" w.c.; -2.5 mbar to 3.75 mbar).

Because of balanced valve construction, Z models offer superior performance at an economic price to other type atmospheric regulators.

Covenient tap locations are provided on the 210Z models, for downstream sensing, cross con-

#### TYPICAL APPLICATIONS

##### Ratio Regulator

Reference to controlled combustion air.

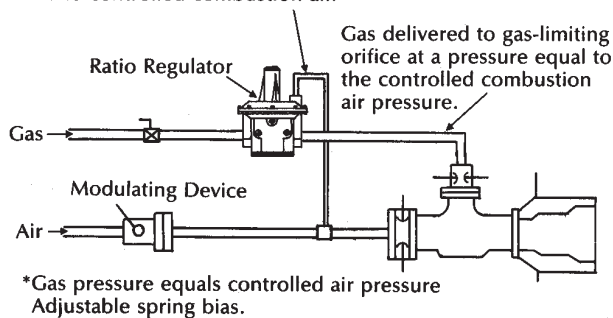

## Z Series

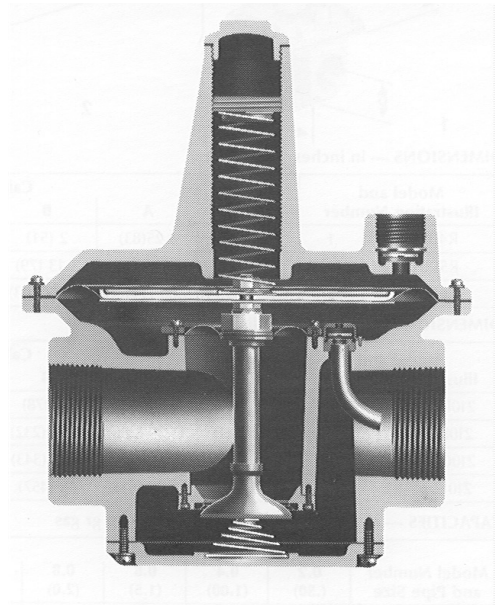

### Zero Governor

nections, and differential control. Four locations can be tapped and plugged for measuring pressure (see back page).

Pipe sizes are consistent with standard models — 3/8" to 1" for the RZ series, and 1" to 4" for the 210Z series. Metric threads are also available.

Maxitrol Z model regulators are used for flow control of burners, nozzle mixers, mixing tees, and proportional premixers.

##### Atmospheric Regulator

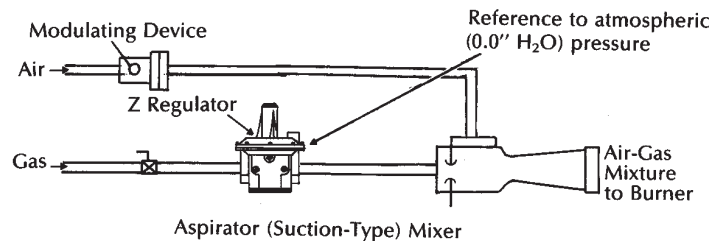

# Dimensions and Capacities

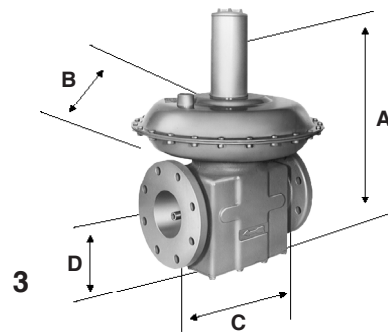
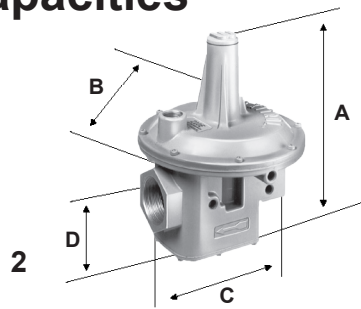
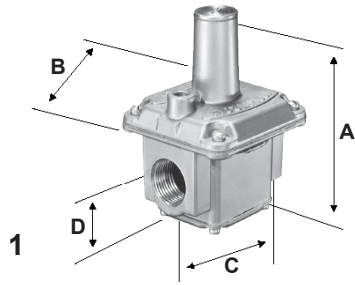

## DIMENSIONS — in inches (millimeters)

Model and Illustration Number	Swing Radius	Call-Outs				
		A	B	C	D	
R400Z	1	2.38 (60)	3.25 (83)	2 (51)	2 (51)	.94 (24)
R500Z	1	3.56 (90)	4.69 (119)	3.13 (79)	3 (76)	1.19 (30)
R600Z	1	4.32 (109.7)	5.68 (144.3)	3.88 (98.3)	4.03 (102.4)	1.46 (37.1)

## DIMENSIONS — in inches (millimeters)

Model and Illustration Number	Swing Radius	Call-Outs				
		A	B	C	D	
210DZ	2	5.44 (138)	9 (229)	7 (178)	6 (152)	2.38 (60)
210EZ	2	8.31 (211)	11.25 (286)	9.13 (232)	8 (203)	2.94 (75)
210GZ	2	11.88 (302)	16.5 (419)	13.5 (343)	11.75 (138)	4.56 (116)
210JZ	3	18.38 (467)	24.25 (616)	18 (457)	13.75 (349)	5.44 (138)

## SENSING TAPS AVAILABLE

Vertical vent tapped — 3/8" NPT on 210D, 1/2" NPT on 210E, 3/4" NPT on 210G & J

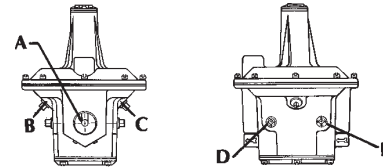

- A. Internal sensing #7 — furnished as standard.
- B. Remote sensing tap #5.
- C. Remote sensing tap #6.
- D. Outlet pressure tap #2. #1 on side opposite.
- E. Inlet pressure tap #4. #3 on side opposite.

## CAPACITIES — expressed in CFH (m³/h) @ 0.64 sp gr gas

Model Number and Pipe Size	Pressure Drop inches w.c. (mbar)											
	0.2 (.50)	0.4 (1.00)	0.6 (1.5)	0.8 (2.0)	1.0 (2.5)	1.5 (3.7)	2.0 (5.0)	2.5 (6.2)	3.0 (7.5)	3.5 (8.7)	4.0 (10.0)	
R400Z*	3/8 X 3/8	77 (2.16)	110 (3.08)	134 (3.75)	155 (4.34)	174 (4.87)	212 (5.94)	245 (6.86)	274 (7.67)	—	—	—
	1/2 X 1/2	86 (2.41)	121 (3.39)	148 (4.14)	172 (4.82)	192 (5.38)	235 (6.58)	271 (7.59)	303 (8.48)	—	—	—
R500Z*	1/2 X 1/2	163 (4.56)	231 (6.47)	283 (7.92)	327 (9.16)	366 (10.25)	447 (12.52)	516 (14.55)	577 (16.16)	635 (17.78)	685 (19.18)	730 (20.44)
	3/4 X 3/4	196 (5.49)	277 (7.76)	340 (9.52)	392 (10.97)	438 (12.26)	537 (15.04)	620 (17.36)	693 (19.40)	760 (21.28)	820 (22.96)	876 (24.53)
R600Z	3/4 X 3/4	298 (8.34)	421 (11.79)	516 (14.45)	595 (16.66)	666 (18.65)	816 (22.85)	942 (26.38)	1,054 (29.51)	1,150 (32.20)	1,245 (34.86)	1,335 (37.38)
	1X1	330 (9.24)	468 (13.10)	572 (16.02)	661 (18.21)	739 (20.69)	906 (25.37)	1,046 (29.29)	1,169 (32.73)	1,280 (35.84)	1,380 (38.64)	1,480 (41.44)

\* C.S.A. certified

## CAPACITIES — expressed in CFH (m³/h) @ 0.64 sp gr gas

Model Number and Pipe Size	Pressure Drop inches w.c. (mbar)											
	0.1 (.25)	0.3 (.75)	0.5 (1.25)	1.0 (2.5)	3.0 (7.5)	5.0 (12.5)	7.0 (17.4)	1/2 psi (34.5)	3/4 psi (51.7)	1psi (68.9)	1.5 psi (103.4)	
210DZ	1 X 1	—	—	—	900 (25.20)	1600 (44.80)	2000 (56.00)	2400 (67.20)	3300 (92.40)	4100 (114.80)	4750 (133.00)	5800 (162.40)
	1 1/4 X 1 1/4	—	—	—	1100 (30.80)	1900 (53.20)	2500 (70.00)	2900 (81.20)	4100 (114.80)	5000 (140.00)	5850 (163.80)	7150 (200.20)
	1 1/2 X 1 1/2	—	—	—	1200 (33.60)	2100 (58.80)	2700 (75.60)	3200 (89.60)	4500 (126.00)	5500 (154.00)	6350 (176.40)	7750 (217.00)
210EZ	1 1/2 X 1 1/2	—	1050 (29.40)	1350 (37.80)	1915 (53.60)	3315 (92.80)	4280 (119.80)	5065 (141.80)	7125 (199.50)	8725 (244.30)	10075 (282.10)	12340 (345.50)
	2 X 2	—	1210 (33.90)	1560 (43.70)	2210 (61.90)	3825 (107.10)	4940 (138.80)	5845 (163.70)	8225 (230.30)	10070 (282.00)	11630 (325.60)	14245 (399.00)
210GZ	2 1/2 X 2 1/2	1410 (39.50)	2450 (68.60)	3160 (88.50)	4470 (125.20)	7740 (216.70)	9995 (279.90)	11825 (331.10)	16635 (465.80)	20375 (570.50)	23525 (658.70)	28810 (806.70)
	3 X 3	1555 (43.50)	2695 (75.50)	3475 (97.30)	4920 (137.80)	8520 (238.60)	11000 (308.00)	13020 (364.60)	18310 (512.70)	22425 (627.90)	25890 (724.90)	31710 (887.90)
210JZ	4 X 4	2700 (75.60)	4700 (131.60)	6000 (168.00)	8600 (240.80)	15000 (420.00)	19000 (532.00)	23000 (644.00)	32000 (896.00)	40000 (1120.00)	45500 (1274.00)	55700 (1559.60)

**MAXITROL**

Maxitrol Company  
23555 Telegraph Rd., PO Box 2230  
Southfield, MI 48037-2230 U.S.A.

www.maxitrol.com  
© 2007 Maxitrol Company,  
All Rights Reserved.