

SIEMENS



www.scccombustion.com

Technical Instructions July 7, 2017

LMV3... Linkageless Burner Management System

Combustion Controls

Intentionally Left Blank

Section 1

Overview

Section 2

Wiring

Section 3

Parameters

Section 4

Commissioning

Section 5

VSD

Section 6

Troubleshooting

Section 7

Modbus

Section 8

ACS410

Appendix A

Application Guide

Section 1

Overview

Section 2

Wiring

Section 3

Parameters

Section 4

Commissioning

Section 5

VSD

Section 6

Troubleshooting

Section 7

Modbus

Section 8

ACS410

Appendix A

Application Guide

Section 1-1: Overview

The LMV3 Burner / Boiler Management System (BMS) is ideally suited for use with steam boilers, hot water boilers, thermal fluid heaters, and industrial burners. The LMV3 is extremely flexible, and encompasses the following features:

- Flame safeguard (independent processor)
- Fuel-air ratio control
- Variable Frequency Drive (VFD) control
- Fuel usage monitoring
- Simultaneous operation of up to 2 rotary actuators (up to 3 connected)
- Dual fuel switchover
- Modbus communication
- Remote firing rate from building automation or external controller
- Valve proving / valve leak testing



Figure 1-1: The Main Components of an LMV3 System

Section 1-2: LMV3 System Builder

The LMV3 Linkageless Burner Management System is comprised of many components in addition to the LMV3 itself. Use the following pages to choose the components needed for your specific application. See pages 13 and 15 for an LMV3 system order sheet.

Control Panel Components

Base Unit – Qty (1) Required

Choose one of the following LMV3 options. See page 17 for mounting information.



LMV37.420A1

Single fuel burner control with electronic fuel-air ratio control of up to 2 actuators and a VFD, with floating/bumping capability. Requires an external PID controller

LMV36.520A1

Dual fuel burner control with electronic fuel-air ratio control of up to 2 actuators (3 connected) and a VFD, without floating/bumping capability. Requires an external PID controller

Display – Qty (1) Required

Each LMV3 must be equipped with one AZL23.00A9 display. See page 18 for mounting information and panel cutout dimensions.



AZL23.00A9

Backlit programming display unit

Display Cable – Qty (1) Required

Each LMV3 must be equipped with a cable to connect the AZL23 display to the LMV3.



TDCCOMBO

Pre-made 10 foot cable and adapter for connecting the AZL23 display to the LMV3

Control Panel Components (continued)**Base Plug Set – Qty (1) Required**

The terminal plug set for the LMV3 is sold separately. Each LMV3 needs one base plug set.

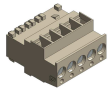
**AGG3.131**

Plug set containing all terminals for an LMV3 system.
Does not include terminals for the AGM60

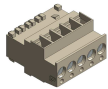
**AGG3.132**

10-pack of plug set AGG3.131

Dual Fuel Module – Qty (1) Recommended with LMV36 Controllers

The AGM60 dual fuel module is used to switch inputs and outputs between fuels on an LMV36 controller. See page 19 for mounting information.

**AGM60.4A9**

Dual fuel module for switching inputs and outputs
between fuels (LMV36 only)

Dual Fuel Module Accessories – Required with AGM60

One plug set and one connecting cable are required when using an AGM60 dual fuel module.

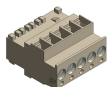
**AGG3.161**

Plug set containing all terminals for an AGM60 dual
fuel module

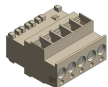
**AGG3.162**

10-pack of plug set AGG3.161

**AGV61.100**

Cable required to connect the AGM60 to the LMV36
controller, 3 foot length

Control Panel Components (continued)

Dual Fuel Module Accessories – Optional

The following accessories are optional when using an AGM60 dual fuel module.



AGG4.200

Mounting bracket to mount the AGM60 directly on top of the LMV36 controller for a smaller footprint

Touchscreens – Optional

Touchscreen kits are available to provide a human machine interface for the LMV3. Kits come with a touchscreen and a plate kit with all necessary inputs and outputs. Standard communication is via Modbus TCP/IP. Other communication types are available. For more technical information about touchscreens, refer to Document No. TS-1000.



TS...

Touchscreen kits with 6" or 10" touchscreen, power supply, interconnect terminals, and optional PLC

Modbus Interface Module – Optional

A separate interface module is required for Modbus communication with the LMV3. The cable that connects the interface module to the LMV3 is provided with the module.



OCI412.10

Modbus interface module for the LMV3

Control Panel Spare Parts – Optional

The LMV3 has one replaceable main power fuse. Each LMV3 comes with a spare fuse. Additional spare fuses are available if necessary.



FUSE6.3A-SLOW

5 pack of LMV3 primary fuses - 6.3A, 250V, 5x20mm, slow blow, for 120 VAC power

Control Panel Components (continued)

Replacement green connectors are available if necessary. 5-pin connectors are for terminals X64 and X74. 6-pin connectors are for actuator terminals X53 and X54.



1840395(5)

5 pack of spare 5-pin green connectors



1840405(3)

3 pack of spare 6-pin green connectors

Replacement plugs and cables are available for the OCI412.10 Modbus interface module.



PLUG412.10

Replacement plugs for terminals X10 and X20 on the OCI412.10 Modbus interface module



CABLE412.10

Replacement cable for connecting the OCI412.10 Modbus interface module to the LMV3

A step up transformer is available to increase the voltage to a flame rod in order to boost the flame signal.



A5Q20002669

Step up transformer for flame rod

Air Damper Assembly

Actuator – Qty (1) Required

Choose one of the following actuators for the air damper. For more information, refer to Document No. N7813.



SQM33.550A9	27 in-lb torque, 10mm “D” shaft, 5-80 seconds
SQM33.750A9	90 in-lb torque, 10mm “D” shaft, 17-80 seconds
SQM33.550A9-N4	Same as SQM33.550A9 but with a NEMA 4 seal
SQM33.750A9-N4	Same as SQM33.750A9 but with a NEMA 4 seal

Coupling – Qty (1) Required (Provided With Some Mounting Brackets – See Below)

Zero-lash, flexible couplings are available for SQM33... actuators. For more information, refer to Document No. CPBK-1000.



CCM10DCA...

Flexible couplings for SQM33... actuators

Mounting Bracket Kits - Optional

Modular bracket kits are available to assist in mounting an SQM33... actuator to a variety of valves or air dampers. A coupling is necessary when using a modular bracket kit. For more information, refer to Document No. CPBK-2000.



BR-AS...

Modular bracket kits for mounting SQM33... actuators to a variety of valves or dampers

Air Damper Assembly (continued)

When retrofitting a Cleaver Brooks boiler, the following kit is available for the rotary air damper. No additional couplings are needed with this retrofit kit. Refer to Document No. CPBK-4000 for technical information or Document No. CPBK-4100 for installation instructions.

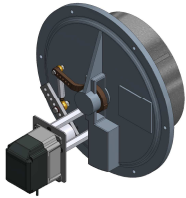

BR-3345CBAIR

Bracket for mounting an SQM33... actuator to a Cleaver Brooks rotary air damper

When using a Lucoma air damper, the following actuator mounting kit is available. No additional couplings are needed with this mounting kit. Refer to Document No. CPBK-3000 for technical information or Document No. CPBK-3100 for installation instructions.

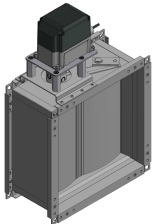

BR-SQM3345-LUC

Bracket for mounting an SQM33... actuator to an 8x8 through 28x28 Lucoma air damper

Gas Firing Rate Control Valve

Valve Actuator Assemblies – Qty (1) Required if Firing Gas

Pre-built valve actuator assemblies are available that mount an SQM33... actuator to a VKG... gas butterfly valve. A variety of VKG... valves are available from 1/2" to 4". For more information about VKG... valves, refer to Document No. CVLV-2000. For more information about valve actuator assemblies using VKG... valves, refer to Document No. VA-1000.

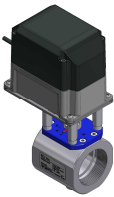

VA33-NF-050	SQM33 to 1/2" full port firing rate valve
VA33-NF-075	SQM33 to 3/4" full port firing rate valve
VA33-NF-100	SQM33 to 1" full port firing rate valve
VA33-NM-100	SQM33 to 1" medium port firing rate valve
VA33-NF-125	SQM33 to 1-1/4" full port firing rate valve
VA33-NM-125	SQM33 to 1-1/4" medium port firing rate valve
VA33-NF-150	SQM33 to 1-1/2" full port firing rate valve
VA33-NM-150	SQM33 to 1-1/2" medium port firing rate valve
VA33-NR-150	SQM33 to 1-1/2" reduced port firing rate valve
VA33-NF-200	SQM33 to 2" full port firing rate valve
VA33-NM-200	SQM33 to 2" medium port firing rate valve
VA33-NR-200	SQM33 to 2" reduced port firing rate valve
VA33-NF-250	SQM33 to 2-1/2" full port firing rate valve
VA33-NM-250	SQM33 to 2-1/2" medium port firing rate valve
VA33-NR-250	SQM33 to 2-1/2" reduced port firing rate valve
VA33-NF-300	SQM33 to 3" full port firing rate valve
VA33-NM-300	SQM33 to 3" medium port firing rate valve
VA33-NR-300	SQM33 to 3" reduced port firing rate valve
VA33-NF-400	SQM33 to 4" full port firing rate valve
VA33-NM-400	SQM33 to 4" medium port firing rate valve
VA33-NR-400	SQM33 to 4" reduced port firing rate valve

Gas Firing Rate Control Valve (continued)

Pre-built valve actuator assemblies are available that mount an SQM33... actuator to a VKF... gas butterfly valve. A variety of VKF... valves are available from 1-1/2" to 8". The most common assemblies are listed below. For more information about VKF... valves, refer to Document No. CVLV-1000. For more information about valve actuator assemblies using VKF... valves, refer to Document No. VA-3000.

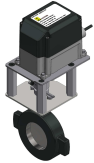

VA33-3.0VKF	SQM33 to 3" VKF butterfly valve
VA33-4.0VKF	SQM33 to 4" VKF butterfly valve
VA33-6.0VKF	SQM33 to 6" VKF butterfly valve

Oil Firing Rate Control Valve

Valve Actuator Assemblies – Qty (1) Required if Firing Oil (Not Using a Cleaver Brooks Oil Valve)

Pre-built valve actuator assemblies are available to mount an SQM33... actuator to a Hauck S or AS series oil valve. For more information about valve actuator assemblies using Hauck oil valves, refer to Document No. VA-4000.



VA33...

Valve actuator assemblies mounting an SQM33... actuator to a Hauck oil valve

Cleaver Brooks Oil Valve Retrofit Kit - Optional

When retrofitting a Cleaver Brooks boiler, the following kit is available for the oil metering valve. Refer to Document No. CPBK-5000 for technical information or Document No. CPBK-5100 for installation instructions.

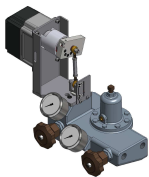

BR-45CBOIL

Bracket for mounting an SQM33... actuator to a Cleaver Brooks oil metering valve

Actuator Accessories

NEMA 4 Kits – Optional

A kit is available to add a NEMA 4 seal to any SQM33... actuator.

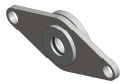

BR-N4-SQM33

NEMA 4 kit for SQM33 actuators

Plug Adapters – Optional

For use with 220V LMV3 controls, plug adapters are available to convert the RAST 2.5 actuator terminals on the LMV3 to RAST 3.5 terminals, in order to improve ease of wiring.



**ADP-SQM33-
 RAST2.5-3.5-AIR**

SQM33 plug adapter for air actuator (220V LMV3 only)

**ADP-SQM33-
 RAST2.5-3.5-FUEL**

SQM33 plug adapter for fuel actuator (220V LMV3 only)

Variable Frequency Drive (VFD) Components

Variable Frequency Drives (VFDs) - Optional

Pre-programmed Variable Frequency Drives (VFDs) are available for use with the LMV3. Braking resistors and line / load reactors are available as accessories.



DR...

Pre-programmed VFDs with LMV3 programming and wiring instructions

Variable Frequency Drive (VFD) Components (continued)

Speed Sensor Mounting Kit – Qty (1) Required per VFD

Because the LMV3 requires speed feedback when using a VFD, one of the following speed sensor kits is required if a VFD is present.



AGG5.305

Speed sensor and associated mounting kit with connections available for mounting directly to ½” or ¾” conduit. Includes speed sensor, 6 foot cable, 3-finger speed wheel, O-ring for a watertight seal, and necessary mounting hardware
Range: 300-6300 RPM

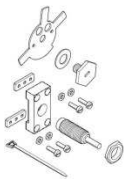

AGG5.310

Speed sensor and associated mounting kit. Includes speed sensor, 6 foot cable, 3-finger speed wheel, and necessary mounting hardware
Range: 300-6300 RPM

Flame Scanners

Ultraviolet Flame Scanners – Qty (1) Required

Two ultraviolet flame scanners are available: one normal sensitivity and one high sensitivity. Neither scanner is a self-checking scanner. For technical information about QRA4... flame scanners, refer to Document No. N7711.



QRA4.U

Ultraviolet flame scanner, forward viewing, normal sensitivity, with ¾” NPSM connection



QRA4M.U

Ultraviolet flame scanner, forward viewing, high sensitivity, with ¾” NPSM connection

Flame Scanner Accessories

QRA4... Accessories – Optional

Mounting accessories are available for the QRA4... flame scanners. For more information, refer to Document No. N7711.



	THERMAL-75X75	Thermal barrier for use with the QRA4... flame scanners. Adapts a 3/4" NPSM thread to a female 3/4" NPT connection. Rated for scanner tube temperatures up to 280 °F
	AGG02	Heat insulating lens with spring washer and O-ring, for applications where the temperature at the scanner will exceed 176 °F, to be mounted inside thermal barrier THERMAL-75X75

ACS410 Software for Laptop

The ACS410 software for the LMV3 offers many features including parameter backups, startup reports, and trending. The software may be downloaded at www.scccombustion.com.

ACS410 Cables – Qty (1) Required if Using the ACS410 Software

To use the ACS410 software, cables are necessary to connect the LMV3 to a PC.

	OCI410.20	User-level PC interface module and cable. Permits access to user level parameters only without the ability to perform parameter backups
	OCI410.30	Service-level PC interface module and cable. Permits access to user and service level parameters and the ability to perform parameter backups
	OCI410.40	OEM-level PC interface module and cable. Permits access to all parameters and the ability to perform parameter backups

LMV3 SYSTEM ORDER SHEET Email: customerservice@scccombustion.com				
Company Name:		Required Ship Date & Address:		
Project Name/Number:				
PO #:				
	Description	Part Number	Qty	
Control Panel Components	Base Unit (Qty 1 Required)	Single fuel	LMV37.420A1	
		Dual fuel	LMV36.520A1	
	Display Unit (Qty 1 Required)	Programming display unit	AZL23.00A9	
	Display Cable (Qty 1 Required)	Pre-made cable and adapter	TDCCOMBO	
	LMV3 Plug Set (Qty 1 Required)	Single terminal plug set	AGG3.131	
		10-pack terminal plug set	AGG3.132	
	Dual fuel module (Typically used w/ LMV36)	Input / output switching unit	AGM60.4A9	
	AGM60 Plug Set (Qty 1 Required w/ AGM60)	Single terminal plug set	AGG3.161	
		10-pack terminal plug set	AGG3.162	
	Connecting Cable (Required with AGM60)	AGM60 to LMV36 connecting cable	AGV61.100	
	Stacking bracket (Optional with AGM60)	AGM60 mounting bracket	AGG4.200	
	Touchscreen (Optional)	Write in part number (see Doc. No. TS-1000)		
	Modbus Module (Optional)	Modbus interface module	OCI412.10	
	Control Panel Spare Parts (Optional)	5-pack of 120V main fuses	FUSE6.3A-SLOW	
		5-pack of 5 pin connectors	1840395(5)	
3-pack of 6 pin connectors		1840405(3)		
Replacement plugs for OCI		PLUG412.10		
Replacement cable for OCI		CABLE412.10		
Flame rod transformer		A5Q20002669		
Air Damper Assembly	Actuator (Qty 1 Required)	27 in-lb, 10mm "D"	SQM33.550A9	
		90 in-lb, 10mm "D"	SQM33.750A9	
		27 in-lb, 10mm "D", NEMA 4	SQM33.550A9-N4	
		90 in-lb, 10mm "D", NEMA 4	SQM33.750A9-N4	
	Coupling (Qty 1 Required)	Write in part number (see Doc. No. CPBK-1000)		
	Mounting Bracket Kits (Optional)	Write in part number (see Doc. No. CPBK-2000)		
	Cleaver Brooks Retrofit Kits (Optional)	Retrofit kit for SQM33	BR-3345CBAIR	
	Lucoma Air Damper Mounting Brackets (Optional)	Retrofit kit for SQM33 (see Doc. No. CPBK-3000)	BR-SQM3345-LUC	

Intentionally Left Blank

	Description		Part Number	Qty
Gas Firing Rate Control Valve	Valve Actuator Assemblies <i>(Qty 1 Required if Firing Gas)</i>	Write in part number (See Doc. No. VA-1000 or VA-3000)		
	Valve Actuator Assemblies <i>(Qty 1 Required if Firing Oil and Not Using a Cleaver Brooks Oil Valve)</i>	Write in part number (see Doc. No. VA-4000)		
Oil Firing Rate Control Valve	Cleaver Brooks Retrofit Kits <i>(Optional)</i>	Retrofit kit for SQM33 (See Doc. VA-5000)	BR-45CBOIL	
	NEMA 4 Kits <i>(Optional)</i>	NEMA 4 kit for SQM33 actuators	BR-N4-SQM33	
Actuator Accessories	Plug Adapters <i>(Optional)</i>	Plug adapter for air actuator	ADP-SQM33-RAST2.5-3.5-AIR	
		Plug adapter for fuel actuator	ADP-SQM33-RAST2.5-3.5-FUEL	
VFDs	Variable Frequency Drives, Brake Resistors, Line/Load Reactors <i>(Optional)</i>	Write in part number (Contact SCC)		
	Speed Sensor Kits <i>(Qty 1 Required per VFD)</i>	Speed sensor kit for conduit	AGG5.305	
		Speed sensor kit w/o conduit	AGG5.310	
Flame Scanner	Flame Scanners <i>(Qty 1 Required)</i>	UV forward view <i>(non self-check)</i>	QRA4.U	
		UV forward view <i>(non self-check; high sensitivity)</i>	QRA4M.U	
	Flame Scanner Accessories <i>(Optional)</i>	3/4" NPT thermal barrier <i>(rated for 280°F)</i>	THERMAL-75X75	
		Heat insulating glass	AGG02	
ACS410 Software	PC Interface <i>(Optional)</i>	ACS410 software	Download free at www.scccombustion.com	
		User cable to connect LMV to PC	OCI410.20	
		Service cable to connect LMV to PC	OCI410.30	
		OEM cable to connect LMV to PC	OCI410.40	

Intentionally Left Blank

Section 1-3: Mounting

LMV3 Controller

The LMV3 must be mounted inside an enclosure that will protect it from dirt and moisture. The unit should be mounted with four #8 screws (not provided) through the holes in the corners of the LMV3. The panel, which the unit sits on, should be drilled and tapped to accommodate these screws.

During the mounting process, consideration should be given to the various plugs and wires that must be attached to the LMV3. Electrical connections are made via plugs that are located in the face of the unit with wires coming out to the top, bottom, and left side of the unit. A space of at least one inch is recommended above, below, and to the left of the LMV3. The recommended total space to leave for the LMV3 is 11" x 7.5" x 3" because the overall dimensions of the LMV3 are 9.06" x 5.31" x 2.36".

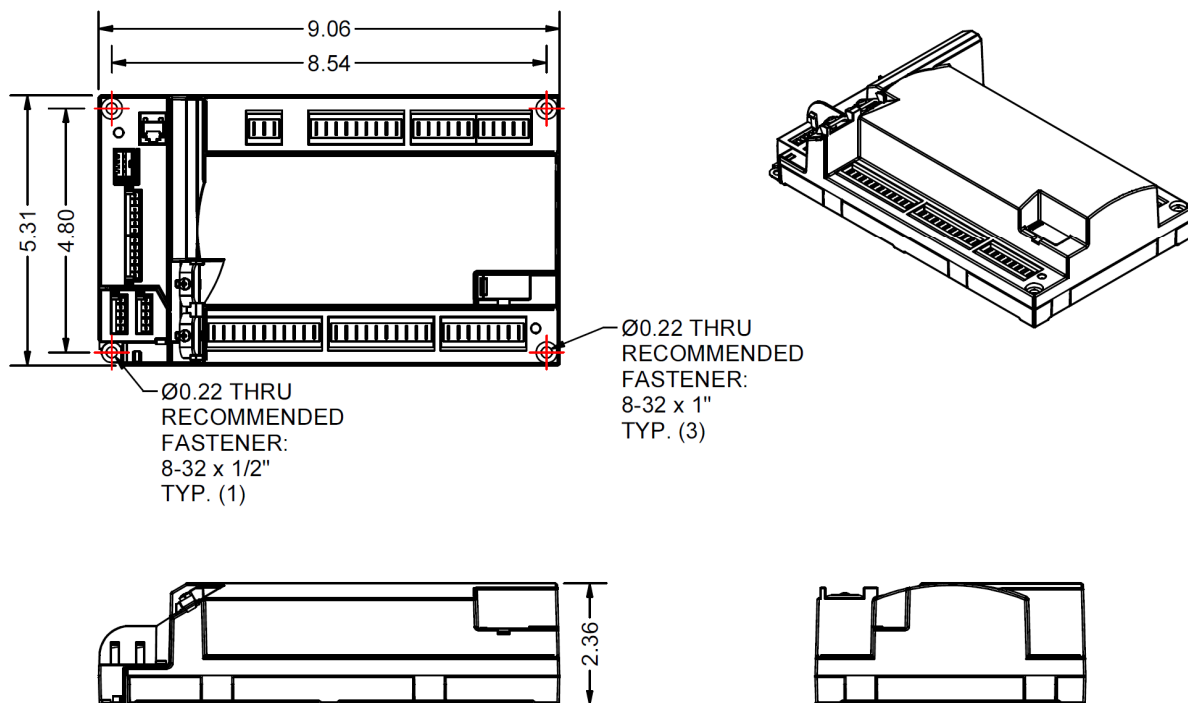

Figure 1-2: LMV3 Dimensions (inches)

AZL23 Display

The AZL23 is designed to be mounted in a rectangular cutout through the face / door of an electrical enclosure. It has one screw on the top and another on the bottom that engage small plastic tabs which will swing out when the screw is tightened clockwise; the screw can be loosened to retract the tab and increase clearance before tightening. The tab will pinch the sheet metal of the enclosure door between itself and the AZL23 gasket. This facilitates easy removal and replacement of the AZL23 since it is designed to be taken out of the enclosure face and held in the hands for setup and commissioning.

The AZL23 connects to the LMV3 at terminal X56 with cable **TDCCOMBO**.

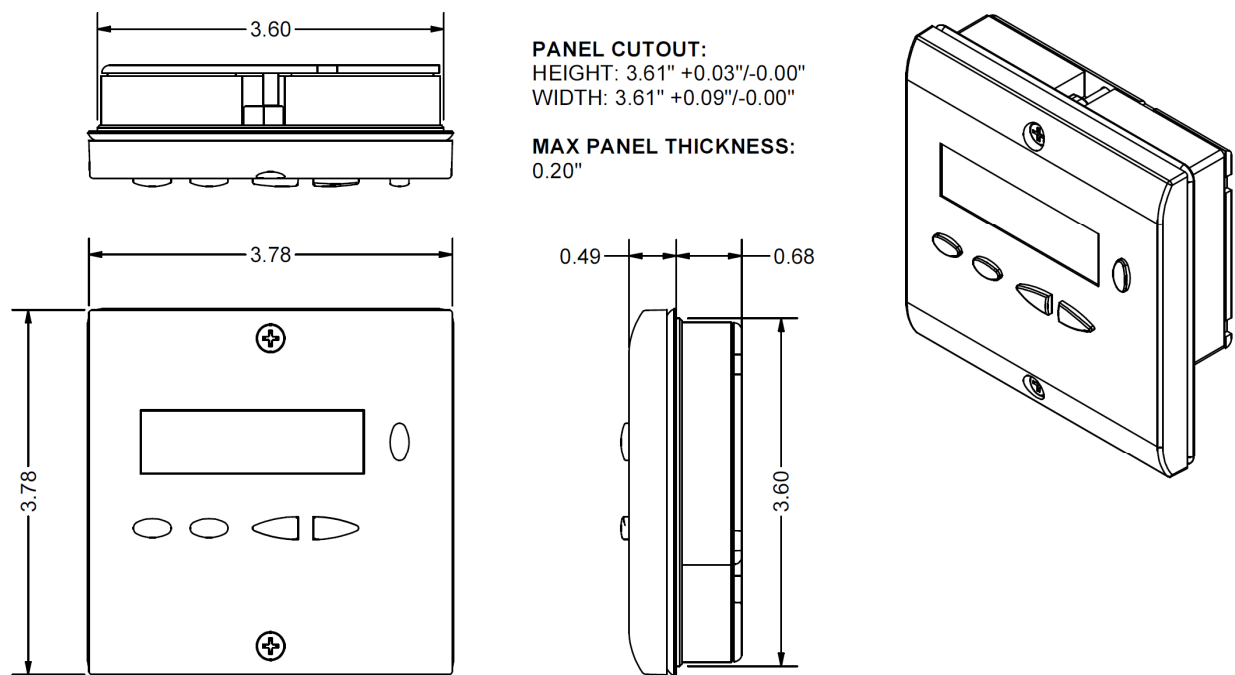

Figure 1-3: AZL23 Dimensions (inches)

AGM60 Dual Fuel Module

The AGM60 must be mounted inside an enclosure that will protect it from dirt and moisture. The unit can be mounted directly on top of the LMV3 using mounting bracket **AGG4.200**. Otherwise, the unit should be mounted with four #8 screws (not provided) through the holes in the corners of the AGM60. The panel, which the unit sits on, should be drilled and tapped to accommodate these screws.

During the mounting process, consideration should be given to the various plugs and wires that must be attached to the AGM60. Electrical connections are made via plugs that are located in the face of the unit with wires coming out to the top and bottom of the unit. A space of at least one inch is recommended above and below the AGM60. The recommended total space to leave for the AGM60 is 9" x 7" x 3" because the overall dimensions of the AGM60 are 7.11" x 4.75" x 2.04".

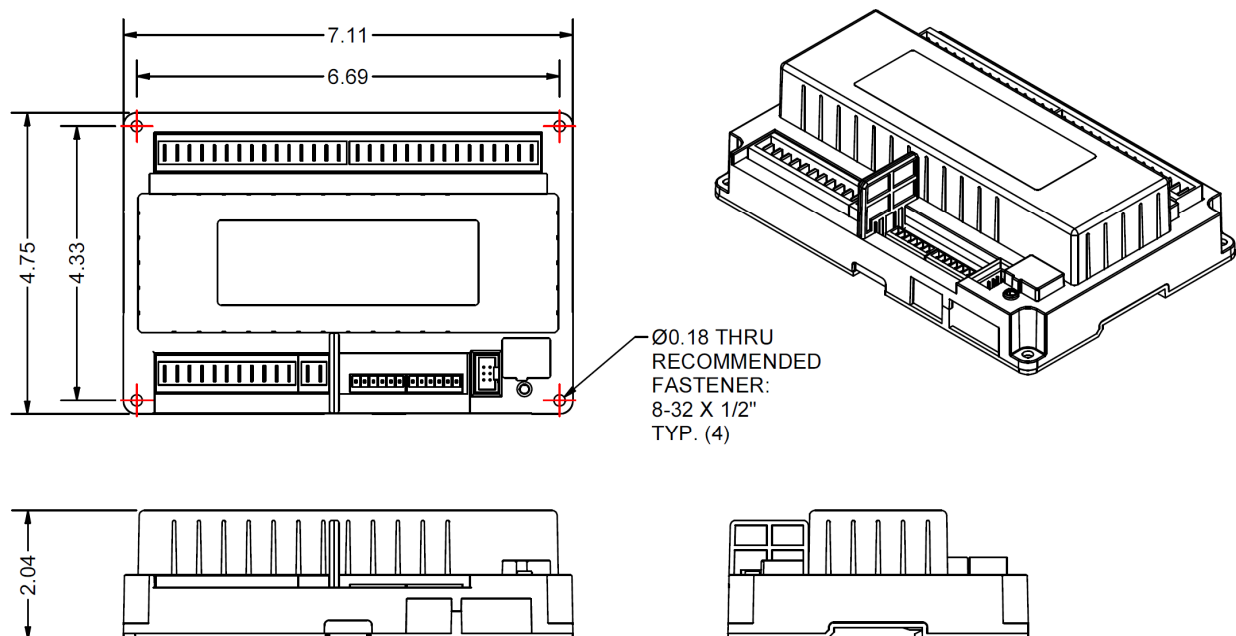

Figure 1-4: AGM60 Dimensions (inches)

Section 1-4: Important Safety Notes

- The LMV3 is a safety device. Under no circumstances should the unit be modified or opened. SCC Inc. will not assume responsibility for damage resulting from unauthorized modification of the unit.
- After commissioning, and after each service visit, the flue gas values should be checked across the firing range.
- All activities (mounting, installation, service work, etc.) must be performed by qualified staff.
- Before performing any work in the connection area of the LMV3, disconnect the unit from the main supply (all-polar disconnection).
- Protection against electrical shock hazard on the LMV3 and all other connected electrical components must be ensured through good wiring and grounding practices.
- Fall or shock can adversely affect the safety functions of an LMV3. Such units must not be put into operation, even if they do not exhibit any apparent damage.
- The coupling that is used between the actuator and the driven valve / damper is safety related, and must be of a robust and flexible design. Should this coupling fail during operation, the LMV3 will no longer have control of the burner's combustion, bringing about a hazardous condition.
- Condensation and the entry of water into the unit must be avoided.

Section 1-5: Approvals

The LMV3 has the following standards and approvals:



Conformity to EEC directives

- Electromagnetic compatibility EMC (immunity)
- Directive for gas-fired appliances
- Low-voltage directive
- Pressure equipment directive

2004/108/EC
2009/142/EC
2006/95/EC
97/23/EC



ISO 9001: 2008
Cert. 00739



ISO 14001: 2004
Cert. 38233



Test specifications:

EN 230, EN 298, EN 1643, EN 12067-2, EN 13611

Intentionally Left Blank

Section 1	Overview
Section 2	Wiring
Section 3	Parameters
Section 4	Commissioning
Section 5	VSD
Section 6	Troubleshooting
Section 7	Modbus
Section 8	ACS410
Appendix A	Application Guide

Section 1	Overview
Section 2	Wiring
Section 3	Parameters
Section 4	Commissioning
Section 5	VSD
Section 6	Troubleshooting
Section 7	Modbus
Section 8	ACS410
Appendix A	Application Guide

2-1: Wiring Introduction

The LMV3 is a very flexible burner control. As such, there are many different ways to wire it. The specific application will dictate the wiring required. This section details the most common applications.

The parameter settings outlined in Section 3 can enable, disable, or change the functionality of many terminals on the LMV3. Thus, wiring and parameter settings work together to make the LMV3 an extremely versatile BMS.

This section includes terminal descriptions (Sections 2-2 and 2-3) and extensive wiring diagrams (Section 2-4) that detail the many applications of the LMV3.

Terminals

The connection terminals of the LMV3 are white RAST 5 and green RAST 3.5 connectors (plugs). Line voltage plugs are keyed so they will only fit into one specific socket of the LMV3, eliminating the possibility of inserting a plug into an incorrect socket.

Each plug is designed to connect one external device or a small group of external devices, such as gas valves, to the LMV3. Each group of plugs on the front of the LMV3 provides line voltage, neutral, and protective earth ground so an additional terminal strip is not necessary.

Note: All protective earth grounds (PE), neutrals (N), and lines (L) are common inside the LMV3.

X9-	01.	04
Plug Group	Plug Number in Group	Pin Number on Plug

Figure 2-1.1: Numbering Scheme on White Line Voltage (RAST 5) Terminals of the LMV3

Note: Dashes or dots can be used interchangeably between the numbers shown above.

X62.	2
Plug Number	Pin Number

Figure 2-1.2: Numbering Scheme on Green Low Voltage (RAST 3.5) Terminals of the LMV3

Terminal descriptions (Sections 2-2 and 2-3) provide a map outlining exactly where the line and low voltage plugs are located.

For each plug, Pin 1 is marked on the casing of the LMV3.

Grounds

The LMV3 has two different types of grounds:

- Protective Earth (PE)
- Reference Ground (GND)

Protective Earth

Protective Earth (PE) or chassis ground must always be connected to the control panel grounding lug. The purpose of PE is to provide a ground for all 120 VAC connections. One wire from the secondary side of the control panel's main step-down transformer should also be connected to the control panel grounding lug.

All of the PE terminals on the LMV3 are common.

Reference Ground

The other type of ground is the Reference Ground (GND). These are found on the low voltage connections. The purpose of the Reference Ground is to serve as a datum to measure other voltages.

2-2: LMV3 Terminal Descriptions

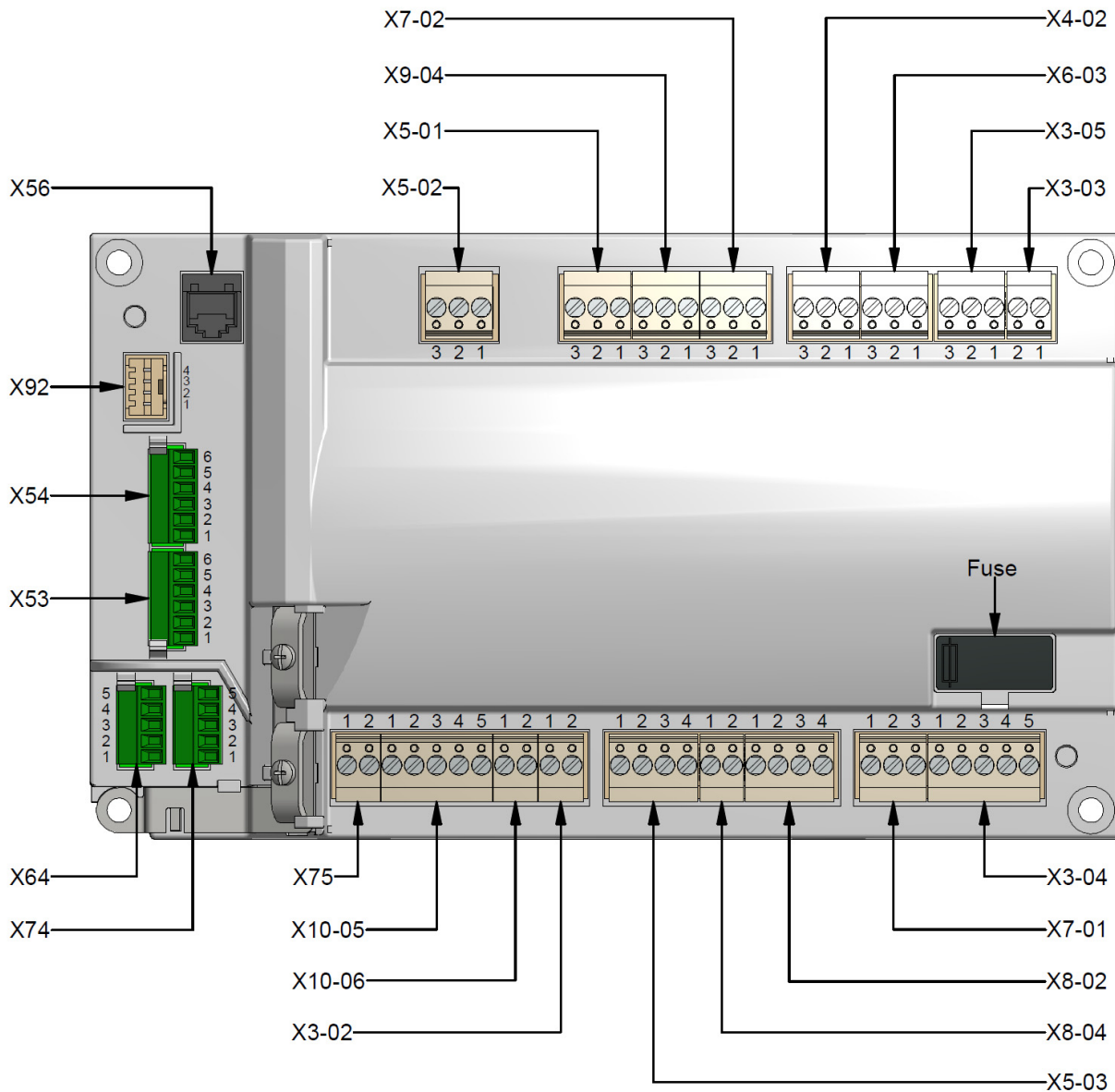

Figure 2-2.1: LMV3 Terminal Layout

General Notes:

- Total combined load of all 120 VAC outputs cannot exceed 5 Amps.
- All "Line, fused" terminals are internally connected.
- All "Neutral" terminals are internally connected.
- All "PE" terminals are internally connected.

LMV3 Terminals				
Terminal	Type	Function	Parameter	Rating
X3-02.1	Programmable Input	Combustion air pressure switch	211 - Fan ramp up time 217 - Max time home run 235 - Air PS	1.5mA, 120VAC
X3-02.2	Line	Line, fused	Not configurable	500mA, 120VAC
X3-03.1	Fixed Input	Burner flange (end of safety limit string)	Not configurable	5A, 120VAC
X3-03.2	Jumper	Burner flange power		
X3-04.1	Fixed Input	Safety loop (safety limits)		
X3-04.2	Line	Safety loop power		
X3-04.3	PE	Incoming power - Protective Earth		N/A
X3-04.4	Neutral	Incoming power - Neutral		
X3-04.5	Line	Incoming power - Line	125 - Mains frequency	6.3A, 120VAC
X3-05.1	Fixed Output	Blower motor starter	Not configurable	1.6A, 120VAC
X3-05.2	Programmable Output	Alarm	210 - Alarm start prevention	1A, 120VAC
X3-05.3	Fixed Output	Continuous purging blower motor starter	Not configurable	1.6A, 120VAC
X4-02.1	PE	Protective Earth ground		N/A
X4-02.2	Neutral	Neutral		
X4-02.3	Programmable Output	Ignition Transformer	226/266/326/366 - Pre-ignition time 227/267/327/367 - Safety time 1 281/381 - Oil ignition start	1.6A, 120VAC
X5-01.1	PE	Protective Earth ground	Not configurable	N/A
X5-01.2	Programmable Input	Low gas pressure switch	214 - Max time start release 236/336 - Low gas PS 285/385 - Pilot LGPS	1.5mA, 120VAC
X5-01.3	Line	Line, fused	Not configurable	500mA, 120VAC
X5-02.1	PE	Protective Earth ground	Not configurable	N/A
X5-02.2	Programmable Input	<u>Gas trains</u> : High gas PS -or- POC -or- valve proving pressure switch <u>Oil trains</u> : High oil PS -or- POC	214 - Max time start release 237/337 - High gas PS 277/377 - High oil PS	1.5mA, 120VAC
X5-02.3	Line	Line, fused	Not configurable	500mA, 120VAC

LMV3 Terminals				
Terminal	Type	Function	Parameter	Rating
X5-03.1	Fixed Input	Burner switch	Not configurable	1.5mA, 120VAC
X5-03.2	Programmable Input	<u>LMV37</u> - Decrease fire rate / stage 3 oil -or- Revert to pilot <u>LMV36</u> - Fuel 0 select	191 - Revert to pilot 205 - Staged config 942 - Active load source	
X5-03.3		<u>LMV37</u> - Increase fire rate / stage 2 oil <u>LMV36</u> - Fuel 1 select	205 - Staged config 942 - Active load source	
X5-03.4	Line	Line, fused	Not configurable	500mA, 120VAC
X6-03.1	PE	Protective Earth ground		N/A
X6-03.2	Neutral	Neutral		
X6-03.3	Fixed Output	Outside main safety valve Typical: Atomizing air compressor or gas booster		2A, 120VAC
X7-01.1	PE	Protective Earth ground		N/A
X7-01.2	Neutral	Neutral		
X7-01.3	Programmable Output	Main fuel valve V2 (downstream) -or- stage 2 oil valve	191 - Revert to pilot 231/271/331/371 - Safety time 2 232/272/332/372 - Interval 2 241/341 - Valve proving	1.6A, 120VAC
X7-02.1	PE	Protective Earth ground	Not configurable	N/A
X7-02.2	Neutral	Neutral		
X7-02.3	Programmable Output	Gas pilot valve -or- stage 3 oil valve	191 - Revert to pilot 227/267/327/367 - Safety time 1 230/270/330/370 - Interval 1 231/271/331/371 - Safety time 2	1.6A, 120VAC

LMV3 Terminals				
Terminal	Type	Function	Parameter	Rating
X8-02.1	Programmable Output	Main fuel valve V1 (upstream) -or- stage 1 oil valve	191 - Revert to pilot 231/271/331/371 - Safety time 2 232/272/332/372 - Interval 2 241/341 - Valve proving	1.6A, 120VAC
X8-02.2	Tie Point	Use as a tiepoint (EU use only)	Not configurable	N/A
X8-02.3	Neutral	Neutral		
X8-02.4	PE	Protective Earth ground		
X8-04.1	Fixed Input	Remote reset and manual lockout	Not configurable	1.5mA, 120VAC
X8-04.2	Fixed Output	Main valve indicator		N/A
X9-04.1	PE	Protective Earth ground		
X9-04.2	Programmable Input	Valve proving pressure switch -or- Low oil pressure switch	217 - Max time home run 241/341 - Valve proving 242/342 - VP evacuation time 243/343 - VP upstream test 244/344 - VP fill time 245/345 - VP downstream test 276/376 - Low oil PS 286 - Start release HO 287 - Max time SRHO	1.5mA, 120VAC
X9-04.3	Line	Line, fused	Not configurable	500mA, 120VAC
X10-05.1	PE	Protective Earth ground		N/A
X10-05.2	Programmable Input	Ionization probe signal (flame rod)	186/187 - FFRT 197 - Flame sensitivity 221/261/321/361 - Flame detector select	1mA
X10-05.3		QRB signal (EU only)		8VDC
X10-05.4	Ground	QRB ground (EU only)	Not configurable	N/A
X10-05.5	Line	Line, fused		500mA, 120VAC
X10-06.1	Programmable Input	QRA signal	186/187 - FFRT 197 - Flame sensitivity 221/261/321/361 - Flame detector select	Max 600µA
X10-06.2	Ground	QRA ground	Not configurable	N/A

LMV3 Terminals				
Terminal	Type	Function	Parameter	Rating
X53.1	Air actuator	Power	Not configurable	N/A
X53.2		Ground		
X53.3		Output channel A		
X53.4		Output channel B		
X53.5		Input channel A		
X53.6		Input channel B		
X54.1	Fuel actuator	Power		
X54.2		Ground		
X54.3		Output channel A		
X54.4		Output channel B		
X54.5		Input channel A		
X54.6		Input channel B		
X56	BCI Port	AZL23 -or- OCI410 PC cable		
X64.1	Programmable Input	4-20 mA (+) for load control -or- VSD speed shift	204 - Invalid analog in 530 - VSD speed shift 550/570 - Shift delay	3-20mA, 460Ω
X64.2		4-20 mA (-) for load control -or- VSD speed shift		
X64.3	Programmable Output	PWM speed control signal (to blower)	542 - VSD activation 641 - VSD standardization 643 - Type speed feedback 644 - Feedback pulse / rev 662 - VSD neutral zone 663 - VSD near zone	1964 Hz carrier frequency
X64.4	Programmable Input	PWM speed feedback (from blower)		14.5-26 VDC, 15-1400 Hz
X64.5	Fixed Output	Power supply for sensor	Not configurable	N/A

LMV3 Terminals				
Terminal	Type	Function	Parameter	Rating
X74.1	Fixed Input	24VDC power supply (+)	Not configurable	24VDC
X74.2		24VDC power supply (-) and speed sensor reference ground		N/A
X74.3	Programmable Output	0/2-10 VDC output for VSD speed -or- load	645 - Analog out config	0/2-10 VDC
X74.4	Programmable Input	Speed sensor pulse input	542 - VSD activation 641 - VSD standardization 643 - Type speed feedback 644 - Feedback pulse / rev 662 - VSD neutral zone 663 - VSD near zone	0-10VDC
X74.5	Fixed Output	Speed sensor power supply	Not configurable	15mA, 10VDC
X75.1	Programmable Input	Fuel meter pulse input, low 0-1.5VDC, high 3-10 VDC	128/129 - Fuel meter scale	0-24 VDC, 0.1-300 Hz
X75.2	Fixed Output	Fuel meter pulse power supply		24VDC, 15mA max
X92	Modbus	Modbus communications port for use with OCI412.10 module	141 - Modbus activation 145 - Modbus address 146 - Baud rate 147 - Parity	N/A

2-3: AGM60 Terminal Descriptions

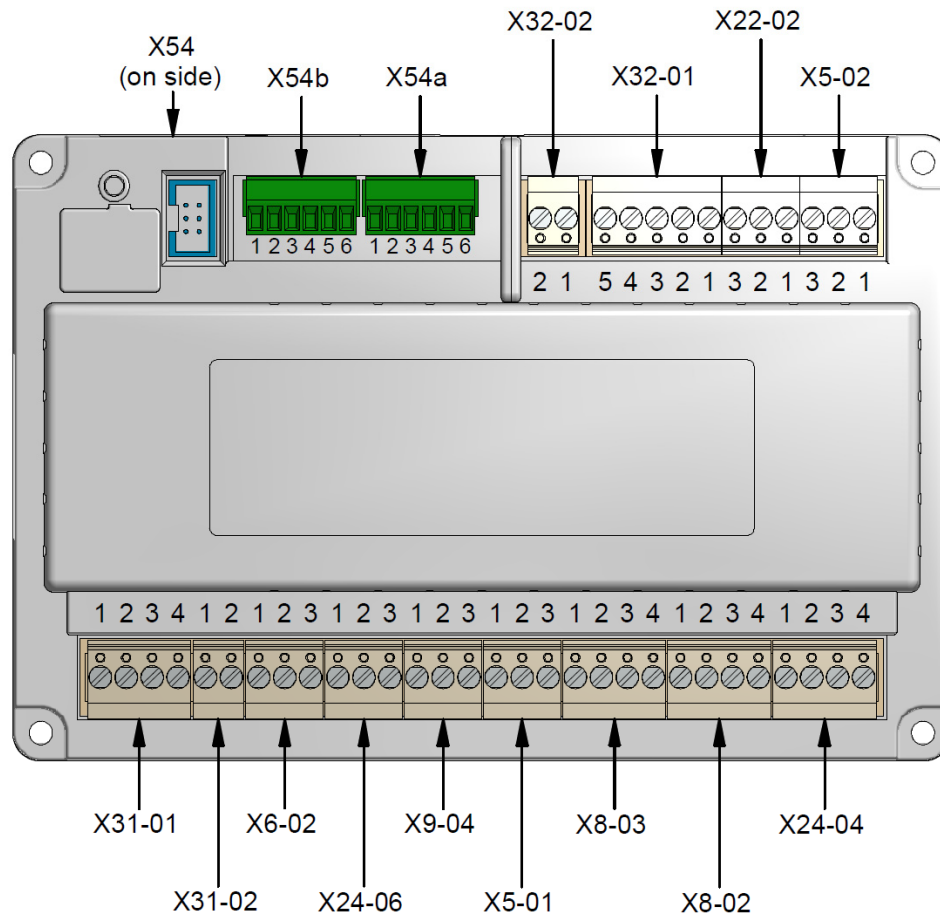

Figure 2-3.1: AGM60 Terminal Layout

General Notes:

- Total combined load of all 120 VAC outputs cannot exceed 5 Amps.
- All "Line, fused" terminals are internally connected.
- All "Neutral" terminals are internally connected.
- All "PE" terminals are internally connected.

AGM60 Terminals			
Terminal	Type	Function	Rating
X5-01.1	PE	Protective Earth ground	N/A
X5-01.2	Input	Valve proving pressure switch -or- low oil pressure switch (fuel 1)	1.5mA, 120VAC
X5-01.3	Line	Line, fused	500mA, 120VAC
X5-02.1	PE	Protective Earth ground	N/A
X5-02.2	Input	<u>Gas trains:</u> High gas PS -or- POC -or- valve proving pressure switch <u>Oil trains:</u> High oil PS -or- POC (fuel 1)	1.5mA, 120VAC
X5-02.3	Line	Line, fused	10mA, 120VAC
X6-02.1	PE	Protective Earth ground	N/A
X6-02.2	Neutral	Neutral	
X6-02.3	Output	Outside main safety valve Typical: atomizing air compressor or gas booster (fuel 1)	1.6A, 120VAC
X8-02.1		Main fuel valve V1 (upstream - fuel 1)	
X8-02.2	Tie Point	Use as a tie point (EU use only)	N/A
X8-02.3	Neutral	Neutral	
X8-02.4	PE	Protective Earth ground	
X8-03.1	Output	Main fuel valve V2 (downstream - fuel 1)	1.6A, 120VAC
X8-03.2	Tie Point	Use as a tie point (EU use only)	N/A
X8-03.3	Neutral	Neutral	
X8-03.4	PE	Protective Earth ground	
X9-04.1			
X9-04.2	Input	Valve proving pressure switch -or- low oil pressure switch (fuel 0)	1.5mA, 120VAC
X9-04.3	Line	Line, fused	500mA, 120VAC
X22-02.1	PE	Protective Earth ground	N/A
X22-02.2	Input	<u>Gas trains:</u> High gas PS -or- POC -or- valve proving pressure switch <u>Oil trains:</u> High oil PS -or- POC (fuel 0)	1.5mA, 120VAC
X22-02.3	Line	Line, fused	10mA, 120VAC
X24-04.1	PE	Protective Earth ground	N/A
X24-04.2	Neutral	Neutral	
X24-04.3	Output	Main fuel valve V2 (downstream - fuel 0)	1.6A, 120VAC
X24-04.4		Main fuel valve V1 (upstream - fuel 0)	

AGM60 Terminals			
Terminal	Type	Function	Rating
X24-06.1	PE	Protective Earth ground	N/A
X24-06.2	Neutral	Neutral	
X24-06.3	Output	Outside main safety valve Typical: atomizing air compressor or gas booster (fuel 0)	1.6A, 120VAC
X31-01.1	Input	Fuel select De-energized = fuel 0 Energized = fuel 1	1.5mA, 120VAC
X31-01.2	PE	Protective Earth ground	N/A
X31-01.3	Neutral	Neutral	
X31-01.4	Line	Line, fused	500mA, 120VAC
X31-02.1	Output	Fuel select fuel 0	Max. 10mA
X31-02.2		Fuel select fuel 1	
X32-01.1		<u>Gas trains</u> : High gas PS -or- POC -or- valve proving pressure switch <u>Oil trains</u> : High oil PS -or- POC (common)	1.5mA, 120VAC
X32-01.2	Input	Main fuel valve V1 (upstream - common)	1.6A, 120VAC
X32-01.3		Main fuel valve V2 (downstream - common)	
X32-01.4	Output	Valve proving pressure switch -or- low oil pressure switch (common)	1.5mA, 120VAC
X32-01.5	Input	Outside main safety valve Typical: atomizing air compressor or gas booster (common)	1.6A, 120VAC
X32-02.1	Output	Burner switch	1.5mA, 120VAC
X32-02.2	Input		
X54	Actuator	Connect cable AGV61.100	N/A
X54a.1	Fuel 1 - Fuel actuator	Power	
X54a.2		Ground	
X54a.3		Output channel A	
X54a.4		Output channel B	
X54a.5		Input channel A	
X54a.6		Input channel B	
X54b.1	Fuel 0 - Fuel actuator	Power	
X54b.2		Ground	
X54b.3		Output channel A	
X54b.4		Output channel B	
X54b.5		Input channel A	
X54b.6		Input channel B	

2-4: Wiring Diagrams

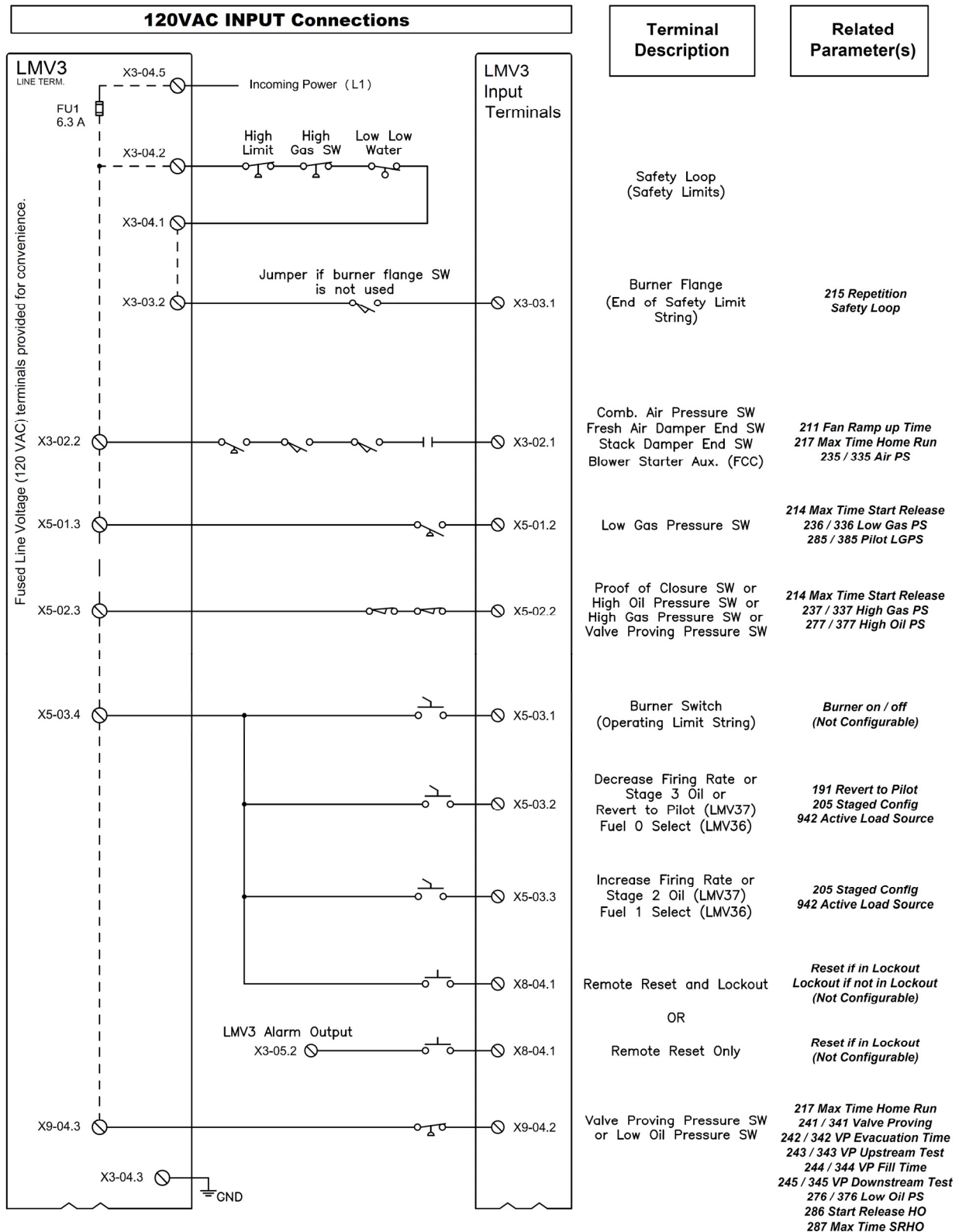

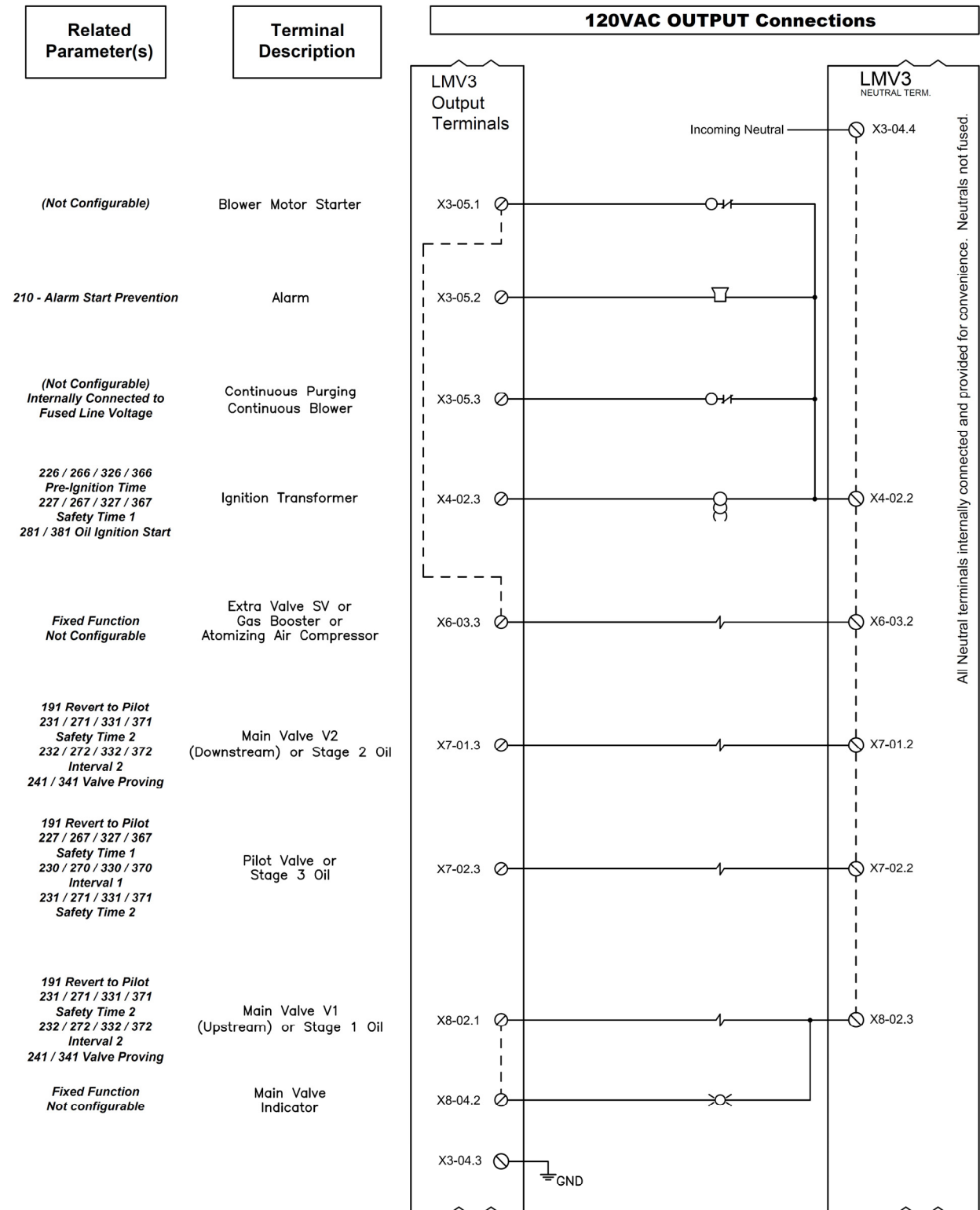

LMV36 + AGM60 120 VAC INPUT Connections - Fuel 0 Gas, Fuel 1 Oil

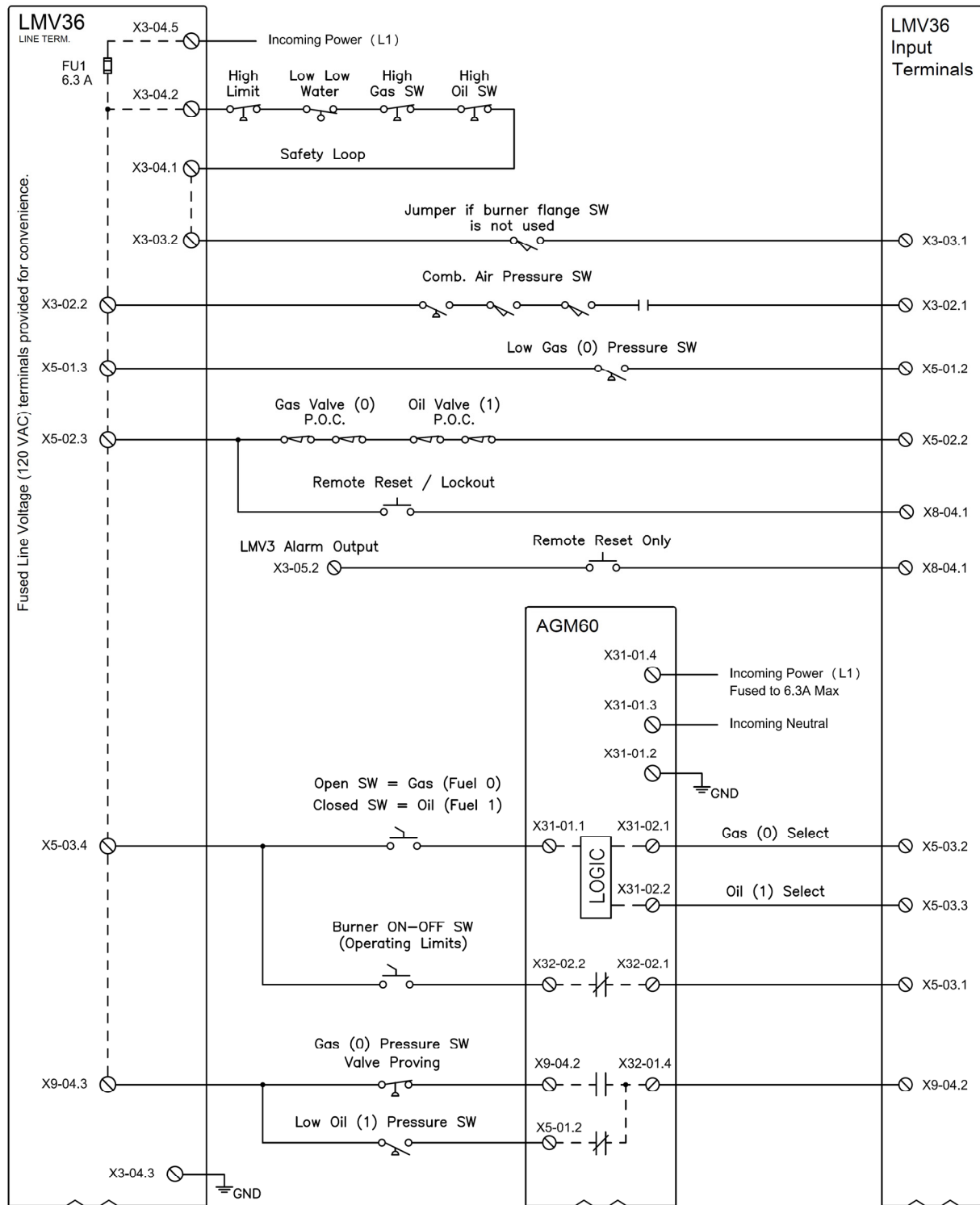

LMV36 + AGM60 120 VAC OUTPUT Connections - Fuel 0 Gas, Fuel 1 Oil

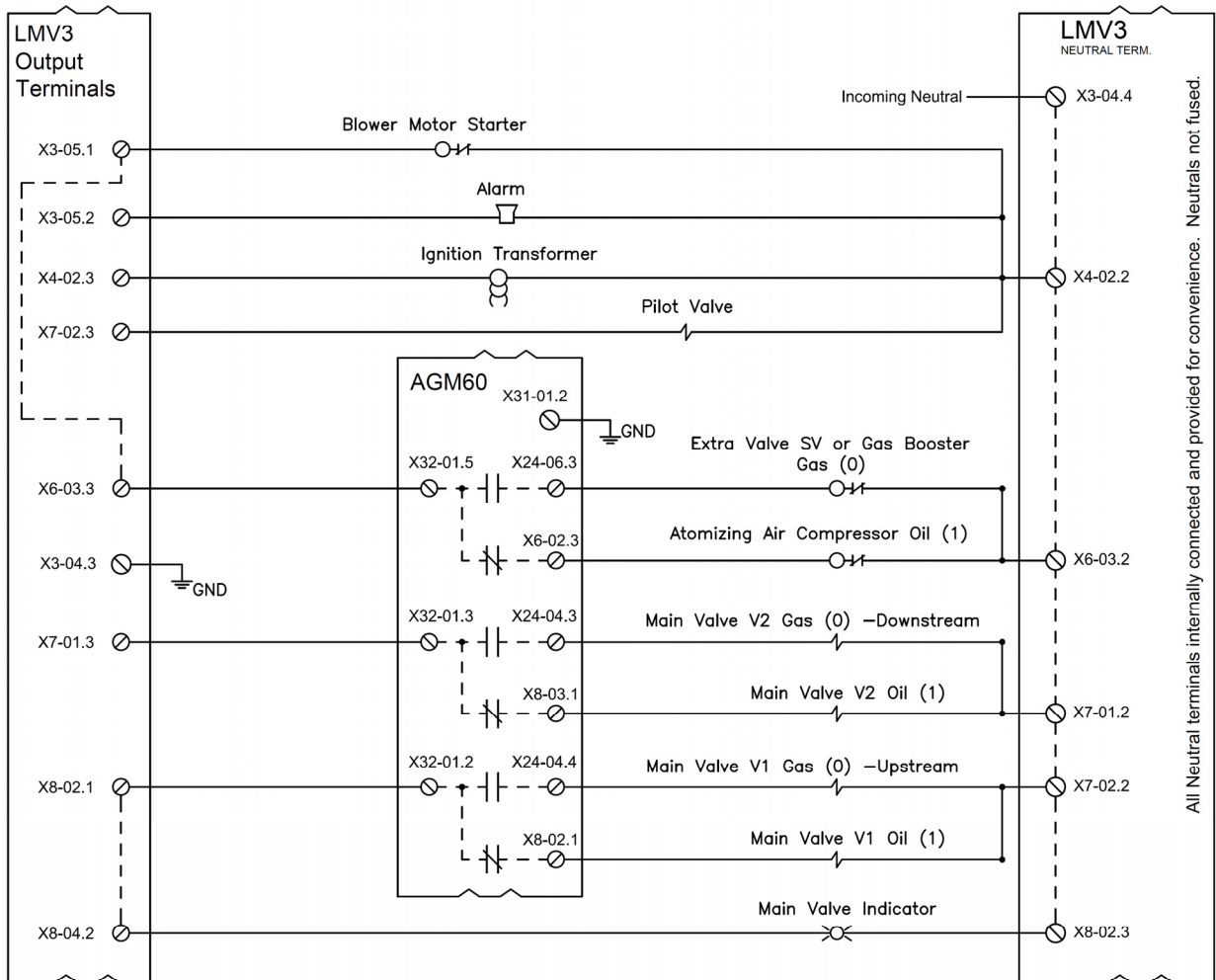

LMV36 + AGM60 FUEL ACTUATOR Connections - Fuel 0 Gas, Fuel 1 Oil

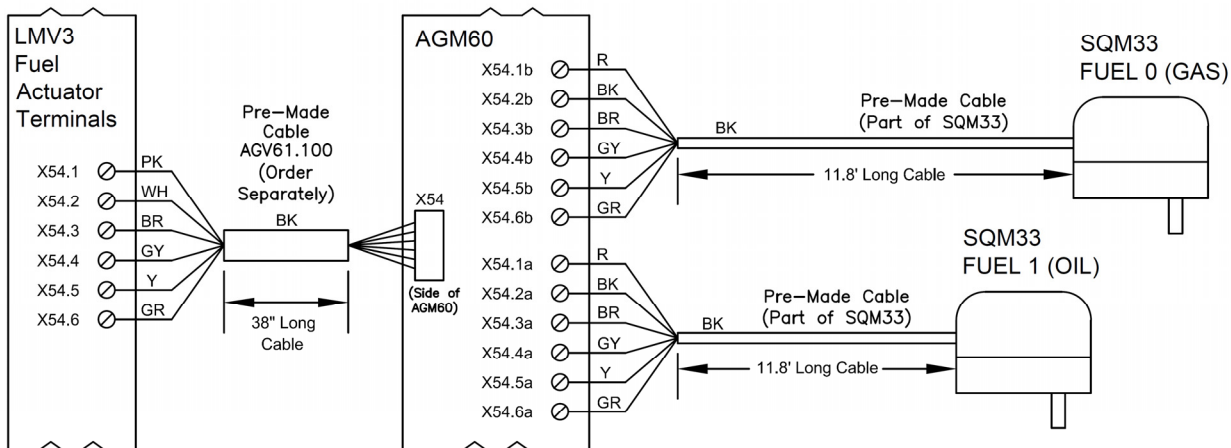

VFD with 3 Phase Motor Connections

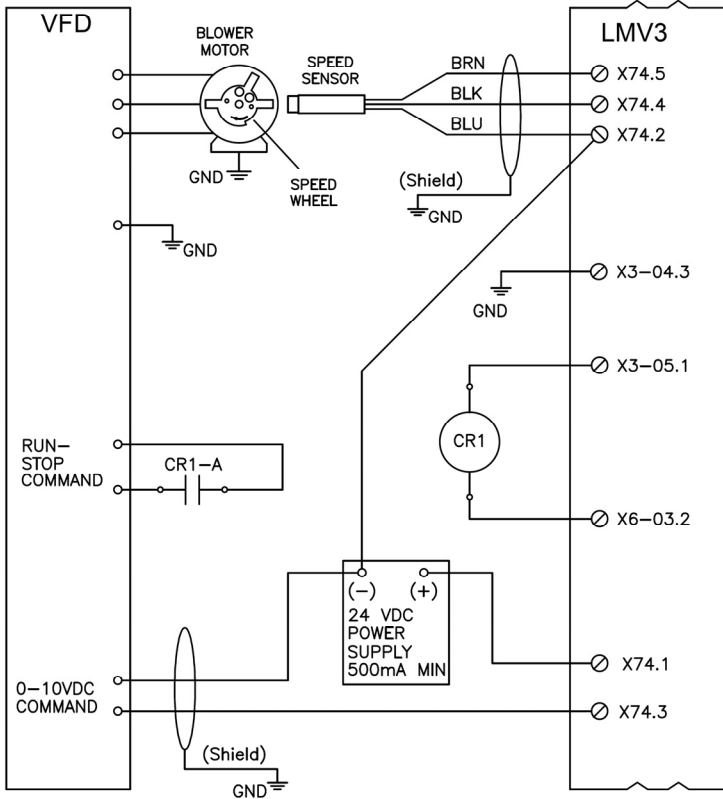

Terminal Description

Related Parameter(s)

Sensor Power
Pulse Input
Reference GND (-)

542 VSD Activation
641 VSD Standardization
643 Type Speed Feedback
644 Feedback Pulse / Rev
662 VSD Neutral Zone
663 VSD Near Zone

Ground

Fixed Function
(Not configurable)

Blower Motor
Starter

Fixed Function
(Not Configurable)

Neutral

Fixed Function
(Not Configurable)

24 VDC in (+)

Fixed Function
(Not Configurable)

0/2-10 VDC (+)
Signal

645 Analog Out Config

Brushless DC Blower (PWM Blower) single phase 120 VAC blower shown

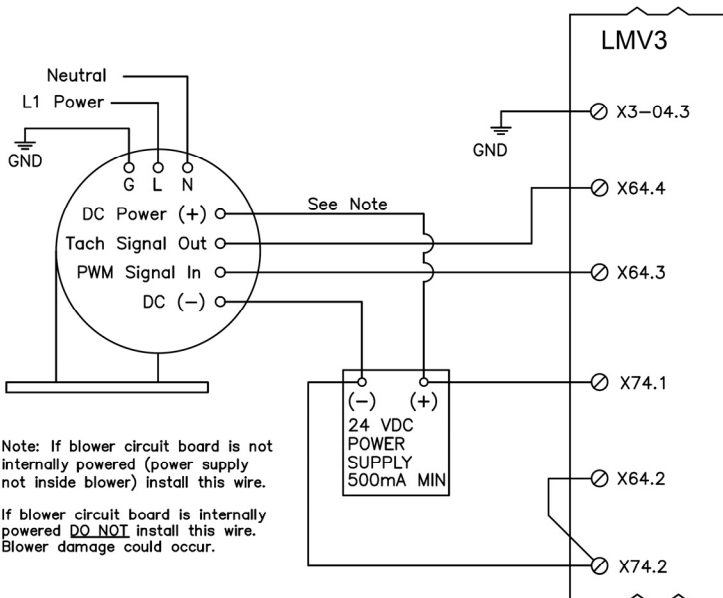

Ground

Fixed Function
Not Configurable

Speed Feedback
(from blower)

542 VSD Activation
641 VSD Standardization
643 Type Speed Feedback
644 Feedback Pulse / Rev
662 VSD Neutral Zone
663 VSD Near Zone

PWM Speed
Control Signal
(to blower)

24 VDC in (+)

Fixed Function
(Not Configurable)

24 VDC (-)

Fixed Function
(Not Configurable)

24 VDC (-)

Fixed Function
(Not Configurable)

Note: If blower circuit board is not internally powered (power supply not inside blower) install this wire.

If blower circuit board is internally powered DO NOT install this wire. Blower damage could occur.

LMV3 LOW VOLTAGE Connections

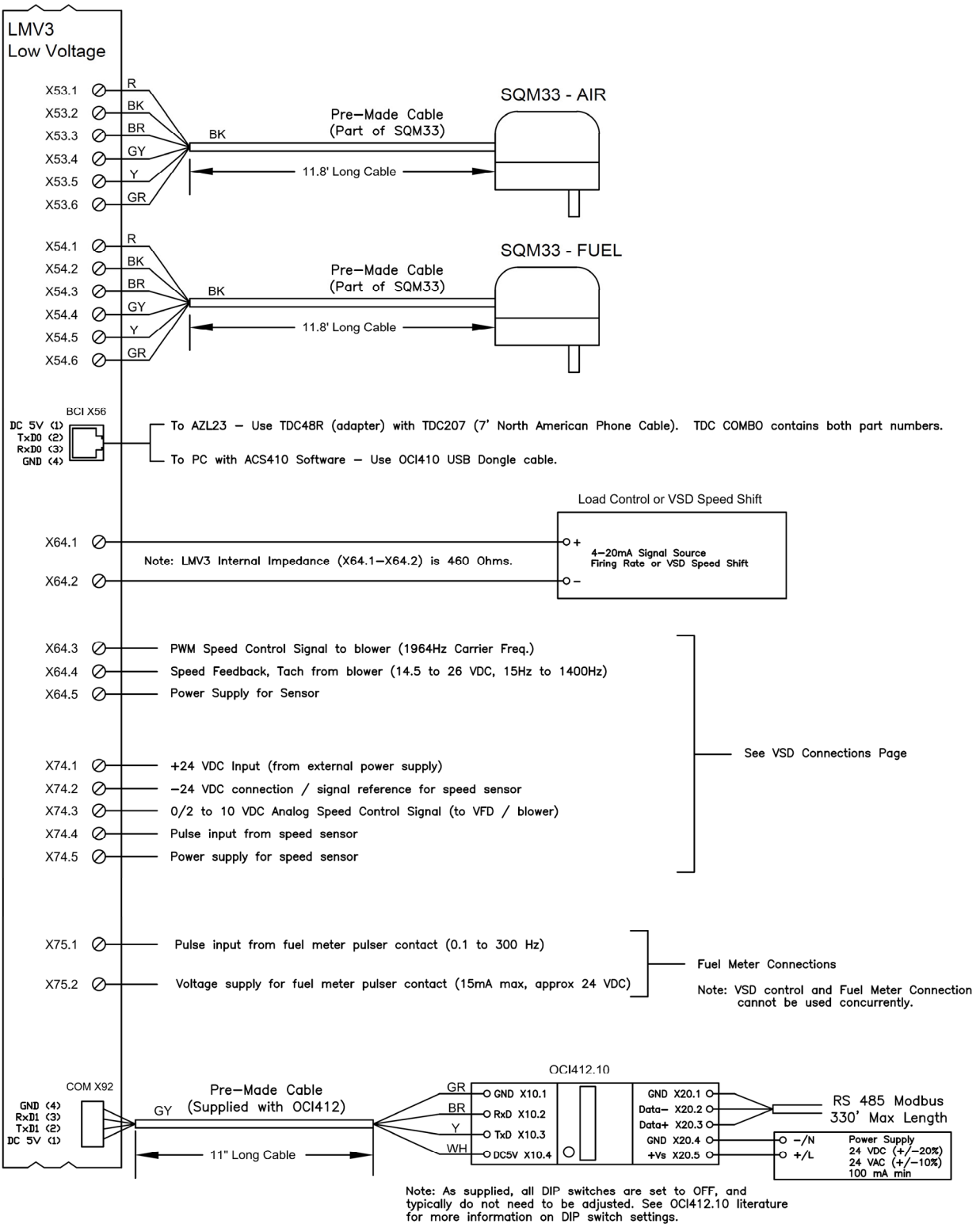

LMV3 UV FLAME DETECTOR Connections

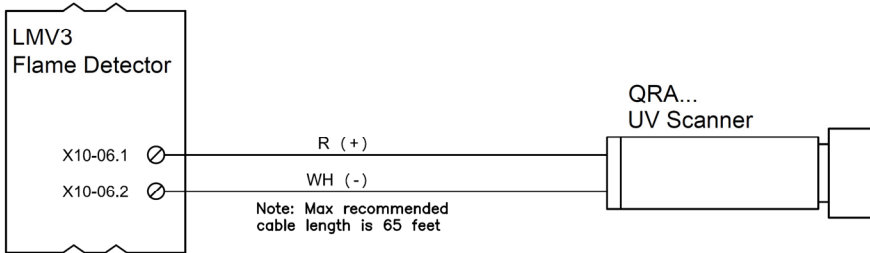

LMV3 FLAME ROD Connections

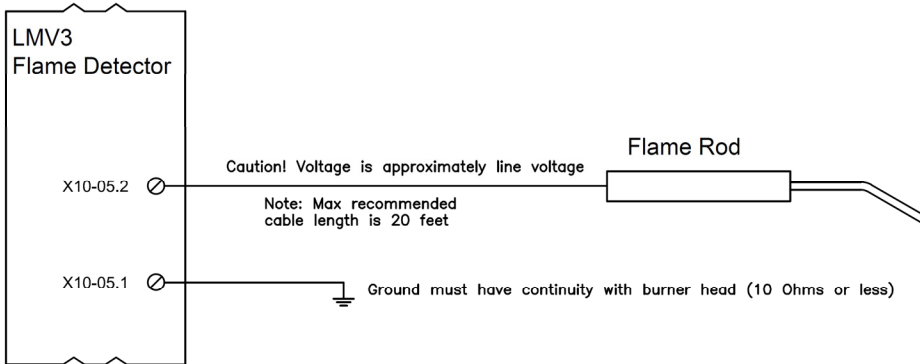

LMV3 FLAME ROD with BOOST TRANSFORMER Connections

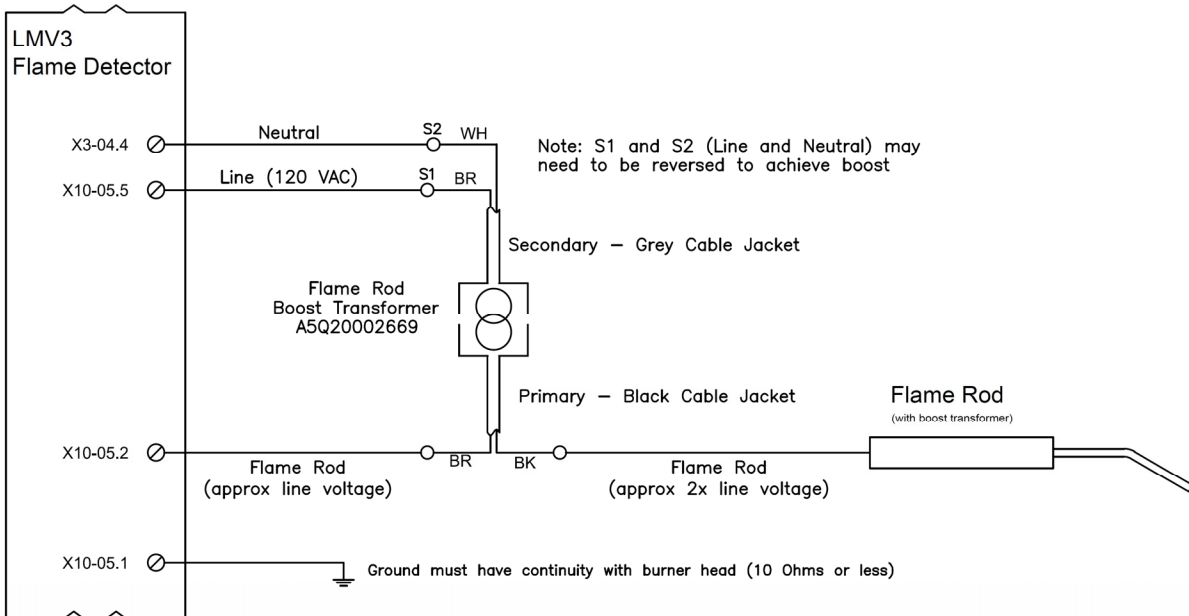

Section 1	Overview
Section 2	Wiring
Section 3	Parameters
Section 4	Commissioning
Section 5	VSD
Section 6	Troubleshooting
Section 7	Modbus
Section 8	ACS410
Appendix A	Application Guide

Section 1	Overview
Section 2	Wiring
Section 3	Parameters
Section 4	Commissioning
Section 5	VSD
Section 6	Troubleshooting
Section 7	Modbus
Section 8	ACS410
Appendix A	Application Guide

Section 3: Parameters

The Siemens LMV3 has a number of parameters that can be adjusted to suit the wide variety of applications that exist in the burner / boiler and industrial heating market.

These parameters are broken up into three main groups by password access:

- User** Level access does not require a password, and encompasses all of the parameters that an end user might have to view or adjust during the life of the burner / boiler.
- Service** Level access does require a password, and encompasses all of the user level parameters, plus additional parameters that a service technician might need to access to tune or maintain the burner / boiler.
- OEM** Level access requires a different password than the service level, and enables the OEM to access all available parameters, including safety-related parameters.

The parameters on the LMV3 are organized into groups of 100. Each group of 100 is described below:

000: Parameter backup / restore / change passwords	500: Special positions / modulation ramps / VSD speed shift
100: General information / configuration / Modbus	600: Actuators and VSD configuration
200: Settings specific to fuel 0	700: Fault history
300: Settings specific to fuel 1 (LMV36 only)	800: N/A
400: Fuel-air ratio curves	900: Operational data

Some parameters have multiple indexes. For example, parameter 501 will initially display as 501:00 (index 0), but can be changed to 501:01 (index 1) or 501:02 (index 2). To move between indexes, use the following procedure:

When first accessing parameter 501, 501:00 will display. The “501” will be flashing. Press the ENTER key once, and the “00” will begin flashing. Press the + or – key to move between the various indexes. In order to change the value stored in an index, press ENTER again and use the + or – key to change the value. Once the correct value is displayed, press ENTER to store it.



Figure 3-1: LMV3 Parameter Example with Indexes

Every LMV3 parameter is described thoroughly in the following LMV3 parameter list. After the parameter list, sequence diagrams for each fuel train available in the LMV3 are provided. For an example of what each of these fuel trains looks like, see Section 4.

Parameter #				Parameter Name	LEGEND - Password Access: U = User, S = Service, O = OEM, U/S = View - User, Write - Service, S/O = View - Service, Write - OEM Shaded Parameters = Frequently Used. ** Parameters = Must Set. Fuel 1 parameters for LMV36 only.			
Fuel 0		Fuel 1			U/S/O	Default	Range	Description
Gas	Oil	Gas	Oil					
000 Level: Parameter Backup / Restore / Change Passwords								
041				Service Level PW	O	9876	Any 4 characters	The service level password can be changed here. It must be exactly 4 characters in length. Enter the same password twice to change it (n = new, r = repeat).
042				OEM Level PW	O	EntrY	Any 5 characters	The OEM level password can be changed here. It must be exactly 5 characters in length. Enter the same password twice to change it (n = new, r = repeat).
050				Backup / Restore	S	Backup - 0 Restore - 0	-99-50	Used to perform parameter backups and restores. Backup: LMV3 transfer to AZL. Restore: AZL transfer to LMV3. Set parameter to 1 and press Enter to begin the backup or restore. When the value changes back to 0, the backup or restore was completed successfully. If the value changes to any other number besides 0, see error code 137 for the cause of the failure.
055				Burner ID AZL		Read only	Burner ID of the LMV3 parameter set currently stored in the AZL.	
056				AZL Parameter Set Associated ASN			Coded LMV3 part number (ASN) associated with the parameter set currently stored in the AZL. Code example for an LMV37.420A1: 056.00 = 3 , 056.01 = 7 , 056.02 = 4 , 056.03 = 2 , 056.04 = 0 , 056.05 = 1 .	
057				AZL Parameter Set Associated SW			Software version of the LMV3 associated with the parameter set stored in the AZL.	
100 Level: General Information / Configuration / Modbus								
102				Production Date	U	Read only	Date that the LMV3 was produced in the DD.MM.YY format.	
103				Serial Number			Serial number of the LMV3.	
104				Default Parameter Set Code			Parameter set code for the default parameters.	
105				Default Parameter Set Version			Version (revision) of the default parameter set.	
107				LMV3 SW Version			Factory loaded LMV3 software version.	
108				LMV3 SW Variant			Factory loaded LMV3 software variant.	
111				Parameter Set Code LMV3	S	Coded LMV3 part number (ASN). For comparison to parameter 056. Code example for an LMV37.420A1: 056.00 = 3 , 056.01 = 7 , 056.02 = 4 , 056.03 = 2 , 056.04 = 0 , 056.05 = 1 .		
113				Burner ID LMV3	U/S	Not set	0-99999999	The burner ID is set here. The burner ID must be all digits (no letters), from 1-8 digits in length. Typically the burner / boiler serial number is used. This serves as an identifier for the parameter set. The burner ID must be set in order to perform a parameter backup.

Parameter #				Parameter Name	LEGEND - Password Access: U = User, S = Service, O = OEM, U/S = View - User, Write - Service, S/O = View - Service, Write - OEM Shaded Parameters = Frequently Used. ** Parameters = Must Set. Fuel 1 parameters for LMV36 only.			
Fuel 0		Fuel 1			U/S/O	Default	Range	Description
Gas	Oil	Gas	Oil					
121				Manual Fire Rate	U	Not set	0-100%	Sets a manual fire rate for the burner. Settings from 20-100% will hold the burner at that fire rate during operation. Settings from 0-19.9% will shut down the burner. A setting of ---- (undefined) sets the burner for automatic mode.
123				Min Load Change	S	123:00 - 0% 123:01 - 1% 123:02 - 0%	0-100%	This serves as a dead band for load changes. If the requested change in fire rate is less than the setting of this parameter, the actuators (and VSD) will not move. Settings of 5% or above may be counterproductive, not permitting the boiler to closely match the load which may in turn cause hunting. Index 00 = fire rate via Modbus (terminal X92) Index 01 = fire rate via analog input (terminal X64) Index 02 = not used.
124				TUV Test		0	-6-1	Activates the loss of flame test (TUV test). Setting this parameter to 1 starts the test. A value of 0 is returned when the test is completed successfully. A negative value is returned if the test was unsuccessful. See error code 150 for the cause of an unsuccessful test.
125				Mains Frequency		1	0-1	Sets the mains frequency: 0 = 50 Hz (Europe) 1 = 60 Hz (US)
126				AZL Brightness		100%	0-100%	Sets the brightness of the backlight on the AZL display. A value of 100% is maximum brightness.
127				Password Timeout	O	60 min	10-120 min	Sets the password timeout on the AZL display. If no buttons are pressed on the AZL display for longer than this period of time, the AZL automatically logs out of the OEM (O) or service (S) level and reverts back to the user (U) level.
128		129		Fuel Meter Scale	S	0	0-400	This sets the number of pulses per unit volume of gas or oil flow, for use with gas or oil meters having a pulsed output.
130				Reset Fault History		0	-5-2	This parameter is used to delete the fault history from the user (U) level only. The service level fault history cannot be deleted. To delete the user level fault history, change this parameter to 1, press Enter, then change to 2, and press Enter again. This must be done within 6 seconds. If done successfully, this parameter will return to 0. If done too slowly, this parameter will change to -1.
133		134		Load for TUV		Not set	20-100%	This sets the load for the loss of flame test (TUV test).
141				Modbus Activation		0	0-2	Sets the Modbus operating mode: 0 = off (inactive) 1 = on (active) 2 = not used
142				Modbus Watchdog		120 sec	0-7200 sec	If no communication occurs for this period of time, the LMV3 considers the Modbus to be unavailable and will look for a fire rate command from another source (see parameter 942 for more details). A setting of 0 makes the timeout inactive and the LMV3 will wait for the Modbus communication to be available again.
143				Spare	U	1	1-8	This parameter is not used.
144				Spare	S	30 sec	10-60 sec	This parameter is not used.

Parameter #				Parameter Name	LEGEND - Password Access: U = User, S = Service, O = OEM, U/S = View - User, Write - Service, S/O = View - Service, Write - OEM Shaded Parameters = Frequently Used. ** Parameters = Must Set. Fuel 1 parameters for LMV36 only.		
Fuel 0		Fuel 1			U/S/O	Default	Range
Gas	Oil	Gas	Oil				
145				S	1	1-247	Sets the LMV3 address for Modbus (job specific).
146					1	0-1	Sets the baud rate of the Modbus port X92: 0 = 9600 bit/s 1 = 19200 bit/s
147					0	0-2	Sets the parity of the Modbus port X92: 0 = none 1 = odd 2 = even
148	149	Default Load			Not set	0-100%	This sets the fire rate when Modbus communication is interrupted. A setting from 20-100% will set the output of the burner. A setting of 0-19.9% will shut down the burner.
161				U	Read only		Displays the total number of faults the LMV3 has received. Not resettable.
162	172	Operating Hours			Reset only		Displays the total number of hours in operation. This value can be reset by pressing the left or right arrow to change the value to 0 and then pressing Enter.
163					Read only		Displays the total number of hours the LMV3 has been powered. Not resettable.
164	174	Startups			Reset only		Displays the total number of startups. This value can be reset by pressing the left or right arrow to change the value to 0 and then pressing Enter.
165	175	Total Startups			Read only		Parameter only exists on an LMV36: Displays the total number of startups. Not resettable.
166							Displays the total number of startups on both fuels (LMV36), or total startups (LMV37). Not resettable.
167	177	Fuel Used			Reset only		Displays the totalized volume of fuel. This value can be reset by pressing the left or right arrow to change the value to 0 and then pressing Enter.
176	-	Total Revert		Read only		Parameter only exists on an LMV37: Displays the total number of times the burner has used the "revert to pilot" function to switch back to running on the pilot only. Not resettable.	
186	187	Flame Failure Response Time (FFRT)		O	186:00 = 0 186:01 = 0 187:00 = 0 187:01 = 0	0-30	Sets the flame failure response time (FFRT). The LMV3 has a base flame failure response time of approximately 1 second. This setting adds tenths of a second to the base time. For example, the maximum setting of 30 adds 3 seconds to the 1 second base time for a total flame failure response time of 4 seconds. Index 00 = Flame failure response time when using a QRB... flame scanner Index 01 = Flame failure response time when using a QRA... flame scanner or a flame rod
190				S	0	0-1	This setting determines the position that the actuators and VSD will drive to when a lockout occurs: 0 = home position 1 = postpurge position

Parameter #				Parameter Name	LEGEND - Password Access: U = User, S = Service, O = OEM, U/S = View - User, Write - Service, S/O = View - Service, Write - OEM Shaded Parameters = Frequently Used. ** Parameters = Must Set. Fuel 1 parameters for LMV36 only.			
Fuel 0		Fuel 1			U/S/O	Default	Range	Description
Gas	Oil	Gas	Oil					
191		-		Revert To Pilot	S/O	0	0-2	Parameter only exists on an LMV37: This enables or disables the "revert to pilot" function. When the "revert to pilot" function is enabled, load controller input X5-03.3 is no longer used and input X5-03.2 is re-purposed as the input signal for the "revert to pilot" function. See Appendix A for a detailed guide on the "revert to pilot" function. 0 = disabled 1 = enabled when input X5-03.2 is de-energized 2 = enabled when input X5-03.2 is energized
192		-		Revert Min	S	30 sec	5-120 sec	Parameter only exists on an LMV37: When using the "revert to pilot" function, this sets the minimum time the LMV3 will run on the pilot only before switching back to the main valves, even if the signal on input X5-03.2 is calling for the main valves to open before this time expires.
193		-		Revert Max		3600 sec	30-6480 sec	Parameter only exists on an LMV37: When using the "revert to pilot" function, this sets the maximum time the LMV3 will run on the pilot only without receiving a signal on input X5-03.2 to switch back to the main valves before turning the burner off.
194				Repetition Safe 1	O	1	1-4	Sets the number of times the LMV3 will attempt to light-off when a flame failure occurs during pilot trial for ignition or main trial for ignition. After this number of tries, a lockout will occur.
195		-		Repetition HO	S	3	1-16	Parameter only exists on an LMV37: Sets the number of times the LMV3 will attempt to start up if a start release for heavy oil is not met on input X9-04.2. After this number of tries, a lockout will occur. A setting of 16 indicates unlimited repetitions. Parameter 286 defines the point in time when the heavy oil start release is evaluated.
196				Repetition APS	O	1	1-2	Sets the number of times the LMV3 will attempt to proceed past phase 24 when the air pressure switch input X3-02.1 is not energized. After this number of tries, a lockout will occur.
197				Flame Sensitivity	S/O	0	0-1	Sets the flame signal sensitivity during phases 60 to 70 for ION (flame rod) and UV flame detectors. 0 = standard sensitivity 1 = high sensitivity
198				Flame Sensitivity Switch Point		4	2-9	Sets the switching point on the fuel / air ratio curve for high flame sensitivity. 2 = no switching point (always high sensitivity) 3-9 = sets the point (P3-P9) to switch back to standard sensitivity
199				Repetition Actuator Position	O	3	1-3	Sets the number of times the LMV3 will recycle if there is a issue moving the actuators to the commanded positions. After this number of repetitions, a lockout will occur. 1 = no repetitions 2 = 1 repetition 3 = 2 repetitions

Parameter #				Parameter Name	LEGEND - Password Access: U = User, S = Service, O = OEM, U/S = View - User, Write - Service, S/O = View - Service, Write - OEM			
Fuel 0		Fuel 1			Shaded Parameters = Frequently Used. ** Parameters = Must Set. Fuel 1 parameters for LMV36 only.			
Gas	Oil	Gas	Oil		U/S/O	Default	Range	Description
200 Level: Settings Specific to Fuel 0 (LMV36 and LMV37)				300 Level: Settings Specific to Fuel 1 (LMV36 only)				
201		301		Fuel Train**		Not set	1-29	Sets the fuel train. There are 29 options available. See section 4 for details about each option. Setting this parameter to undefined (----) will delete any existing fuel curves.
204				Invalid Analog In	S	0	0-2	This sets the behavior of the LMV3 when the 4-20 mA signal on terminal X64 is out of range. On an LMV37, this parameter has no effect unless "revert to pilot" is enabled via parameter 191. 0 = Drive to low fire or no VSD trim (warning message will be displayed) 1 = Lockout 2 = Drive to low fire or no VSD trim (no warning message will be displayed)
205				Staged Config	O	0	0-1	Parameter only exists on an LMV37. Sets the behavior of terminal X5-03 pin 2 and pin 3 for staged operation: 0 = standard 1 = stages interchanged
208				Program Stop		0	0-4	This parameter will stop the startup sequence in the selected phase. This is useful for commissioning and service work. The LMV3 can be held in the following phases: 0 = deactivated 1 = phase 24 (prepurge position) 2 = phase 36 (ignition position) 3 = phase 44 (interval 1 - pilot stabilization) 4 = phase 52 (interval 2 - main stabilization)
210				Alarm Start Prevent	S	1	0-1	Determines if the alarm output X3-05.2 will be energized in the event of a start prevention (an alarm in standby). The LMV3 will wait 5 seconds after receiving a call for heat before displaying the start prevention on the AZL. 0 = deactivated 1 = activated
211				Fan Ramp Up Time		2 sec	2-60 sec	Sets the length of phase 22, which is the time allowed to let the fan accelerate up to speed before the actuators start driving to prepurge position.
212				Max Time Low Fire		45 sec	0.2-600 sec	The allowable time to let the LMV3 drive to low fire before shutting the fuel valves after a call for heat has been removed from input X5-03.1. In summary, this sets the maximum time for phase 62. This setting does not affect fuel valve closing time in the event of a safety shutdown.
213				Min Time Home Run	O	2 sec	2-60 sec	Sets the minimum time that the LMV3 will stay in phase 10 before proceeding to phase 12. The time does not start until the actuators have finished moving (referencing and driving to home position).

Parameter #				Parameter Name	LEGEND - Password Access: U = User, S = Service, O = OEM, U/S = View - User, Write - Service, S/O = View - Service, Write - OEM Shaded Parameters = Frequently Used. ** Parameters = Must Set. Fuel 1 parameters for LMV36 only.			
Fuel 0		Fuel 1			U/S/O	Default	Range	Description
Gas	Oil	Gas	Oil					
214				Max Time Start Release	O	35 sec	0.2-600 sec	On gas trains, this sets the maximum amount of time before input X5-01.2 must be energized after receiving a call for heat. Typically a low gas pressure switch and / or other start releases are wired to input X5-01.2 on gas trains. On oil trains, this sets the maximum amount of time before input X5-02.2 must be energized after receiving a call for heat. Typically a high oil pressure switch and / or other start releases are wired to input X5-02.2 on oil trains.
215				Repetition SL	S	1	1-16	Sets how many times the LMV3 will attempt to restart without manual reset when the safety loop is opened. This parameter should always be set to 1 (no repetitions). A setting of 16 indicates unlimited repetitions.
217				Max Time Home Run	O	30 sec	5-600 sec	Sets the maximum time to satisfy all conditions required in phase 10 (home run). Two of the conditions that must be met are the air pressure switch input X3-02.1 is de-energized and the actuators have reached their home position. On oil trains, this also sets the maximum time to satisfy the low oil pressure switch in phase 38. The low oil switch is wired to input X9-04.2. This parameter only has effect on the low oil pressure switch if parameter 276 (fuel 0) or 376 (fuel 1) are set to 1. If parameter 276 or 376 are set to 2, the low oil pressure switch must be made by the beginning of safety time 1 (phase 40).
221	261	321	361	Flame Detector Select	S	1	0-1	This parameter sets the type of flame scanner that is connected to the LMV3. 0 = QRB... flame scanner (Europe) 1 = QRA... flame scanner or flame rod (North America)
222	262	322	362	Skip Prepurge		1	0-1	Activates or deactivates prepurge. It is recommended that the prepurge be activated for most burners in North America. 0 = deactivated 1 = activated
223		323		Repetition LGPS		1	1-16	Sets how many times the LMV3 will attempt to proceed past phase 22 if the low gas pressure switch and / or other start releases wired to input X5-01.2 are not made. After this number of tries, a lockout will occur. A setting of 16 indicates unlimited repetitions.
225	265	325	365	Prepurge Time		30 sec	5-3600 sec	Sets the prepurge time (phase 30). Prepurge time will begin once the actuators / VSD have reached their prepurge positions and the air pressure switch input X3-02.1 is energized.
226	-	326	-	Pre-Ignition Time		2 sec	0.4-3600 sec	The period of time that the ignition transformer (output X4-02.3) is energized before the pilot valve (output X7-02.3) for piloted fuel trains. The function is similar for direct ignition fuel trains, except that the timing is before the main valves (outputs X8-02.1 and X7-01.3) instead of the pilot valves. In summary, sets the length of phase 38. On oil trains, this setting has no effect if parameter 281 (fuel 0) or 381 (fuel 1) is set to 1.
-	266	-	366			2 sec	0.6-3600 sec	

Parameter #				Parameter Name	LEGEND - Password Access: U = User, S = Service, O = OEM, U/S = View - User, Write - Service, S/O = View - Service, Write - OEM Shaded Parameters = Frequently Used. ** Parameters = Must Set. Fuel 1 parameters for LMV36 only.			Description
Fuel 0		Fuel 1			U/S/O	Default	Range	
Gas	Oil	Gas	Oil					
227	-	327	-	Safety Time 1	O	5 sec	1-10 sec	When a fuel train with a pilot is used, this setting defines the overlap of the spark (output X4-02.3) and the pilot valve (output X7-02.3). After this time expires, the spark is de-energized but the pilot valve remains open if a flame is still present. If a flame is not sensed, a lockout will occur. If directly spark igniting the main fuel, this defines the overlap of the spark and the main fuel valves (outputs X8-02.1 and X7-01.3). This time is also known as TSA1. In summary, sets the length of phases 40-42.
-	267	-	367			5 sec	1-15 sec	
229	-	329	-	Pressure Reaction Time		1.8 sec	0.4-9.6 sec	
-	269	-	369			1.8 sec	0.4-14 sec	
230	-	330	-	Interval 1	S	2 sec	0.4-60 sec	When a fuel train is selected that has a pilot, this setting defines the pilot stabilizing period. This time begins after TSA1 expires. During this period, only the pilot valve is open. The spark is de-energized. If directly spark igniting the main fuel, this defines the main stabilizing period. In summary, sets the length of phase 44.
-	270	-	370			2 sec	0.4-60 sec	
231	-	331	-	Safety Time 2	O	7 sec	1-10 sec	When a fuel train with a pilot is used, this setting defines the overlap of the pilot (output X7-02.3) and the main fuel valves. After this time expires, the pilot is de-energized. Shorter times are more safe. This parameter has no effect for fuel trains having direct spark ignition of the main fuel. This time is also known as TSA2. Sets the length of phase 50.
-	271	-	371			10 sec	1-15 sec	
232	-	332	-	Interval 2	S	2 sec	0.4-60 sec	This setting defines the main flame stabilizing period at ignition position before modulation. This time begins after TSA2 expires. During this period, only the main fuel valves are open. The pilot valve is de-energized. This setting has no effect for fuel trains having direct spark ignition of the main fuel. Sets the length of phase 52.
-	272	-	372			2 sec	0.4-60 sec	
233	273	333	373	Afterburn Time		8 sec	0.2-60 sec	This setting defines the permissible time for a flame to be detected after the main fuel valves are closed without causing an alarm.
234	274	334	374	Postpurge Time 1		15 sec	0.2-6480 sec	This setting defines the mandatory postpurge time. If a call for heat exists during this time, the LMV3 will still continue to postpurge until this time expires. See parameter 248/284/348/384 for information on the optional postpurge time. Sets the length of phase 74.
235		335		Air PS	S/O	1	1-2	Sets the behavior of the air pressure switch (input X3-02.1): 1 = must be energized from prepurge through postpurge (phases 24-78) 2 = same as option 1 except the input can be de-energized during phases 60-66 without an alarm (only permitted on pneumatic fuel train options - see parameters 201/301)
236	-	336	-	Low Gas PS	S	1	1-3	Sets the location of the low gas pressure switch (input X5-01.2): 1 = before upstream shutoff valve V1 2 = between shutoff valves V1 and V2 (low gas pressure switch is also used as valve proving pressure switch) 3 = downstream of shutoff valves V1 and V2 (for B149.3 compliance)

Parameter #				Parameter Name	LEGEND - Password Access: U = User, S = Service, O = OEM, U/S = View - User, Write - Service, S/O = View - Service, Write - OEM Shaded Parameters = Frequently Used. ** Parameters = Must Set. Fuel 1 parameters for LMV36 only.			
Fuel 0		Fuel 1			U/S/O	Default	Range	Description
Gas	Oil	Gas	Oil					
-	276	-	376	Low Oil PS	S	1	1-2	This setting defines the phase when the low oil pressure switch (input X9-04.2) must be energized: 1 = energized during phase 38 (parameter 217 sets the length of time after the beginning of phase 38 that the input must be energized) 2 = energized by the beginning of safety time 1 (phase 40)
237	-	-	-	High Gas PS		2	1-4	This setting defines the function of input X5-02.2 on gas trains: 1 = high gas pressure switch 2 = POC 3 = valve proving pressure switch 4 = speed dependent air pressure switch
-	-	337	-	High Oil PS		1	1-4	This setting defines the function of input X5-02.2 on oil trains: 1 = high oil pressure switch 2 = POC 3 = not used 4 = speed dependent air pressure switch
239	-	339	-	Forced Intermittent	S/O	1	0-1	When activated, this forces the LMV3 to shut the burner down every 23 hours, 45 minutes of uninterrupted operation. The burner will automatically restart afterwards. The purpose of the shutdown is to check and cycle safety devices. Activating this feature is highly recommended if a non-self check flame scanner is used. 0 = deactivated 1 = activated
-	279	-	379					
240	280	340	380	Repetition Flame	O	1	1-2	This sets the numbers of times a flame failure must occur before causing a lockout. Most North American codes require 1.
241	-	341	-	Valve Proving	S	0	0-3	This setting determines if gas valve proving (leak testing) will be performed. Gas valve proving can be performed on startup, shutdown, or both. If 0 is selected, valve proving will not be performed. 0 = no valve proving 1 = valve proving on startup 2 = valve proving on shutdown 3 = valve proving on startup and shutdown
242	-	342	-	VP Evacuation Time	O	3 sec	0.2-10 sec	If valve proving is performed, this specifies the length of time that the downstream valve (V2) is energized (output X7-01.3). This will evacuate any gas that might exist between the gas valves. Sets the length of phase 80. Note: The time it takes for the gas valve to be at least half open must be less than the maximum value for this parameter.
243	-	343	-	VP Upstream Test		10 sec	0.2-60 sec	If valve proving is performed, this specifies the length of time that both the upstream and downstream valves are closed. If the pressure between the valves rises during this period (enough to open the NC valve proving pressure switch), then the upstream valve is leaking and the LMV3 will lockout. A longer time period will produce a more sensitive test. Sets the length of phase 81.

Parameter #				Parameter Name	LEGEND - Password Access: U = User, S = Service, O = OEM, U/S = View - User, Write - Service, S/O = View - Service, Write - OEM Shaded Parameters = Frequently Used. ** Parameters = Must Set. Fuel 1 parameters for LMV36 only.			Description
Fuel 0		Fuel 1			U/S/O	Default	Range	
Gas	Oil	Gas	Oil					
244	-	344	-	VP Fill Time	O	3 sec	0.2-10 sec	If valve proving is performed, this specifies the length of time that the upstream valve (V1) is energized (output X8-02.1). This will fill the volume between the main gas valves to line pressure. Sets the length of phase 82. Note: The time it takes for the gas valve to be at least half open must be less than the maximum value for this parameter.
245	-	345	-	VP Downstream Test		10 sec	0.2-60 sec	If valve proving is performed, this specifies the length of time that both the upstream and downstream valves are closed. If the pressure between the valves falls during this period (enough to close the NC valve proving pressure switch), then the downstream valve is leaking and the LMV3 will lockout. A longer time period will produce a more sensitive test. Sets the length of phase 83.
246	-	346	-	LGPS Wait Time		10 sec	0.2-60 sec	If there is a lack of gas pressure (low gas pressure switch is open), then the LMV3 will wait this period of time before attempting to relight, provided that parameter 223 (fuel 0) or 323 (fuel 1) is set to a number larger than 1 (not typically done in North America). This time period will double on each successive attempt to relight.
-	281	-	381	Oil Ignition Start	S	0	0-1	On oil trains, this setting defines the point at which the ignition transformer is energized during the startup sequence: 0 = phase 38 (short pre-ignition, use parameter 266 or 366 to set the length of time) 1 = phase 22 (long pre-ignition)
248	284	348	384	Postpurge Time 3		1 sec	1-6480 sec	This setting defines the optional postpurge time. If a call for heat exists during this time, the LMV3 stops postpurging immediately and goes directly to standby. Once the air pressure switch is proven open and the actuators reach their home positions, the burner will startup provided a call for heat still exists. See parameter 234/274/334/374 for information on the mandatory postpurge time. Sets the maximum length of phase 78.
-	285	-	385	Pilot LGPS		0	0-1	Parameter only exists on an LMV36: On oil trains with a gas pilot, this setting defines whether or not a low gas pressure switch is connected to input X5-01.2. If set to 0, input X5-01.2 is ignored on oil. If set to 1, input X5-01.2 must be energized by the end of phase 38. 0 = low gas pressure switch not connected 1 = low gas pressure switch connected
-	286	-	-	Start Release HO		1	0-1	Parameter only exists on an LMV37: When running heavy oil, this setting defines the point in the startup sequence when the start release for heavy oil (input X9-04.2) must be energized. 0 = only in phase 38 1 = phase 38-62
-	287	-	-	Max Time SRHO		45 sec	1-45 sec	Parameter only exists on an LMV37: When running heavy oil, this sets the maximum time to satisfy the heavy oil start release in phase 38. The heavy oil start release is wired to input X9-04.2. After this period of time, the LMV3 will either lockout or attempt to light-off again depending on the setting of parameter 195.

Parameter #				Parameter Name	LEGEND - Password Access: U = User, S = Service, O = OEM, U/S = View - User, Write - Service, S/O = View - Service, Write - OEM Shaded Parameters = Frequently Used. ** Parameters = Must Set. Fuel 1 parameters for LMV36 only.			
Fuel 0		Fuel 1			U/S/O	Default	Range	Description
Gas	Oil	Gas	Oil					
400 Level: Fuel - Air Ratio Curves								
400		Ratio Control**		S	Not set	Points 0-9	This is where actuator position curves and VSD speed curves are set from low to high fire. These position curves determine the fuel-air ratio for the burner across the firing range. Nine points <u>must</u> be set from low to high fire (P1-P9) in addition to the ignition point (P0). See Section 4 for more information on commissioning.	
500 Level: Special Positions / Modulation Ramps / VSD Speed Shift								
501	504	Special Position Fuel		S	00 = 0° 01 = 0° 02 = 15°	0-90°	This sets the special positions for the fuel actuator: Index 00 = home position Index 01 = prepurge position Index 02 = postpurge position	
502	505	Special Position Air			00 = 0° 01 = 90° 02 = 45°	0-90°	This sets the special positions for the air actuator: Index 00 = home position Index 01 = prepurge position Index 02 = postpurge position	
503	506	Special Position VSD			00 = 0% 01 = 100% 02 = 50%	0-100%	This sets the special positions for the VSD / PWM blower: Index 00 = home position Index 01 = prepurge position Index 02 = postpurge position	
522		Ramp Up VSD			10 sec	5-40 sec	This sets the speed that the VSD ramps up. This setting is active during modulation as well as driving to special positions (home, prepurge, ignition, postpurge). Large blowers typically require a longer ramp up.	
523		Ramp Down VSD			10 sec	5-40 sec	This sets the speed that the VSD ramps down. This setting is active during modulation as well as driving to special positions (home, prepurge, ignition, postpurge). Large blowers typically require a longer ramp down.	
529		Separate VSD Ramp			0	0-2	When activated, this allows the air damper to be at purge position when the VSD is ramping to ignition or home position. This provides a braking effect to allow the VSD to ramp down more quickly. 0 = deactivated 1 = activated 2 = activated (50% higher tolerances when fuel valves closed)	

Parameter #				Parameter Name	LEGEND - Password Access: U = User, S = Service, O = OEM, U/S = View - User, Write - Service, S/O = View - Service, Write - OEM		
Fuel 0		Fuel 1			Shaded Parameters = Frequently Used. ** Parameters = Must Set. Fuel 1 parameters for LMV36 only.		
Gas	Oil	Gas	Oil	U/S/O	Default	Range	Description
530		VSD Speed Shift		S/O	0	0-4	This setting enables 4-20 mA input X64 as the input for shifting the VSD speed off of the base curve. If activated, terminal X64 will no longer accept a 4-20 mA input for the load. There are two additional options to consider when activating VSD shift. The first is to enable the controller sending the 4-20 mA signal to test the analog input during phases 24-30 (prepurge). The second is to enable ignition speed shift so that the VSD speed at ignition position can be shifted to provide a more rich light off when the boiler is cold. 0 = deactivated (X64 remains as a 4-20 mA load input) 1 = activated 2 = activated (with analog input test) 3 = activated (with ignition speed shift) 4 = activated (with analog input test and ignition speed shift)
542		VSD Activation		S	0	0-1	This setting activates or deactivates a VSD: 0 = VSD deactivated 1 = VSD activated
544		Modulation Ramp			32 sec	32-80 sec	This setting controls the speed at which the actuators will ramp during phases 60-62 (fuel valves open). The time chosen is how long it would actually take for the actuators to drive from 0-90°. During all other phases, the actuator ramp speed is fixed depending on the model of the SQM33 actuator being used (SQM33.5 = 5 sec, SQM33.7 = 17 sec). If using a VSD, this time should be set at least 20% longer than the longest VSD ramp time (parameters 522 and 523).
545	565	Load Low Fire			Not set	20-100%	Sets the low fire load. During normal operation, the burner will not modulate below this point.
546	566	Load High Fire		Not set	20-100%	Sets the high fire load. During normal operation, the burner will not modulate above this point.	
547	567	VSD Shift Low		S/O	-4%	-15-0%	Sets the absolute lower limit for VSD speed shift. This percentage is based on the standardized speed (parameter 642).
548	568	VSD Shift High			4%	0-25%	Sets the absolute upper limit for VSD speed shift. This percentage is based on the standardized speed (parameter 642).
549	569	Shift Attenuation			88%	0-100%	The attenuation factor for VSD speed shift. This setting gives the ability to have less VSD shift at low fire for a given analog input signal. 100% attenuation means that there will be no shift at low fire and maximum shift at high fire with a linear interpolation between. A setting of 0% results in no attenuation, so the full measure of VSD shift will be used at all firing rates.
550	570	Shift Delay		25 sec	0-255 sec	This setting is a delay timer for VSD speed shift. After the LMV3 reaches normal operation (phase 60), this delay timer starts. After this time expires, the 4-20 mA input on X64 will be used to shift the VSD speed. A setting of 0 seconds deactivates this feature.	
551	571	Shift Limit Time		0 sec	0-3600 sec	If the LMV3 is at the upper or lower VSD shift limit (parameters 547/567 or 548/568) for this amount of time, a warning message will be displayed or a shutdown will occur, depending on the setting of parameter 552/572. A setting of 0 seconds deactivates this feature.	
552	572	Shift Limit Response		0	0-2	Determines the action of the LMV3 if the VSD shift limits are reached: 0 = warning only 1 = warning and VSD shift deactivation 2 = shutdown	

Parameter #				Parameter Name	LEGEND - Password Access: U = User, S = Service, O = OEM, U/S = View - User, Write - Service, S/O = View - Service, Write - OEM Shaded Parameters = Frequently Used. ** Parameters = Must Set. Fuel 1 parameters for LMV36 only.		
Fuel 0		Fuel 1			U/S/O	Default	Range
Gas	Oil	Gas	Oil				
600 Level: Actuator and VSD Configuration							
601	-	Reference Point**		S/O	601:00 = 1 601:01 = 0	0-1	Determines the reference point of the SQM33 actuators. The actuators will reference after a normal shutdown, lockout, or loss of power to the LMV3. In order to reference, the actuators must drive outside of their 0-90° operating range. This parameter sets whether the actuators will reference closed (<0°) or open (>90°). Index 00 = fuel actuator. Index 01 = air actuator 0 = closed (<0°) 1 = open (>90°) Note: The reference point of the air actuator can only be set under parameter 601 and is not displayed under parameter 608.
-	608				1	0-1	
602	-	Rotation Direction**			602:00 = 0 602:01 = 0	0-1	Determines the direction of rotation of the SQM33 actuators. The descriptions of the rotation are valid when the actuator shaft is pointed at your eye. Index 00 = fuel actuator. Index 01 = air actuator 0 = counterclockwise 1 = clockwise Note: The direction of rotation of the air actuator can only be set under parameter 602 and is not displayed under parameter 609.
-	609				0	0-1	
606	-	Position Tolerance			606:00 = 1.7° 606:01 = 1.7°	0.5-4.0°	Determines the allowed tolerance on the position of the actuators. If the actuator's position differs by greater than this amount from the expected position, a lockout occurs. The default setting of 1.7° is recommended. Index 00 = fuel actuator. Index 01 = air actuator Note: The allowed tolerance of the air actuator can only be set under parameter 606 and is not displayed under parameter 610.
-	610				1.7°	0.0-4.0°	
611	-	Reference Type			611:00 = 0 611:01 = 0	0-3	Determines the type of reference of the actuators. These settings should be left at the default values of 0. Index 00 = fuel actuator. Index 01 = air actuator 0 = standard 1 = range stop in the usable range 2 = internal range stop (SQN1... actuators only) 3 = both Note: The type of reference of the air actuator can only be set under parameter 611 and is not displayed under parameter 612.
-	612				0	0-3	

Parameter #				Parameter Name	LEGEND - Password Access: U = User, S = Service, O = OEM, U/S = View - User, Write - Service, S/O = View - Service, Write - OEM			
Fuel 0		Fuel 1			Shaded Parameters = Frequently Used. ** Parameters = Must Set. Fuel 1 parameters for LMV36 only.			
Gas	Oil	Gas	Oil		U/S/O	Default	Range	Description
613		-		Actuator Type	S/O	613:00 = 0 613:01 = 0	0-2	Determines the type of actuators being used. Index 00 = fuel actuator. Index 01 = air actuator 0 = SQM33.5... actuators (27 in-lb, 5 sec / 90°) 1 = Not used 2 = SQM33.7... actuators (90 in-lb, 17 sec / 90°) Note: The type of air actuator being used can only be set under parameter 613 and is not displayed under parameter 614.
-		614				0	0-2	
641				VSD Standardization**	S	0	-25-1	This starts the standardization process for the VSD. Set parameter to 1 and press Enter to begin the standardization process. The air damper will open to the prepurge position, and then the VSD will ramp up and then back down. The air damper will then close. During this time, the LMV3 will correlate a speed signal to the peak motor RPM. If the value changes back to 0, the standardization process was completed successfully. If the value changes to a negative number, see error code 82 for the cause of the failure.
642				Standardized Speed		Read only	This displays the standardized blower motor speed (in RPM) corresponding to a 95% speed signal (if parameter 661 is set to 1, typically VFD) or a 98% speed signal (if parameter 661 is set to 0, typically PWM). This is automatically recorded when the VSD is standardized (see parameter 641). Index 00 = recorded standardized speed in RPM Index 01 = recorded standardized speed in RPM (redundant for monitoring)	
643				Type Speed Feedback	S/O	0	0-1	This sets if the speed signal from the motor is asymmetric or symmetric. If using a VFD and 3-phase motor with a speed wheel, this must be set for asymmetric. Most brushless DC blowers have a symmetric pulsed output. 0 = asymmetric 1 = symmetric
644				Feedback Pulse / Rev		3	1-6	This sets the expected number of pulses per motor revolution. Set for 3 if using the standard 3-finger speed wheel or 6 if using the 6-finger speed wheel. Most brushless DC blowers output 2 or 3 pulses per revolution.
645				Analog Out Config	S	0	0-2	Determines the range of the analog output from terminal X74 (pins 2 and 3). If using a VSD (parameter 542 = 1) with an analog input, this output sends the control signal to the VFD / PWM blower. Otherwise, this output acts as the load output. Setting of this parameter does not affect the separate PWM output on terminal X64 pin 3. 0 = 0-10 VDC 1 = 2-10 VDC 2 = 0/2-10 VDC

Parameter #				Parameter Name	LEGEND - Password Access: U = User, S = Service, O = OEM, U/S = View - User, Write - Service, S/O = View - Service, Write - OEM Shaded Parameters = Frequently Used. ** Parameters = Must Set. Fuel 1 parameters for LMV36 only.			
Fuel 0		Fuel 1			U/S/O	Default	Range	Description
Gas	Oil	Gas	Oil					
647				Speed Eval Time	S/O	8	4-8	Sets how long the LMV3 must pause modulation to read and evaluate the VSD speed. These are in 25 ms increments. Shorter times will allow for the VSD curve to be ramped more steeply between points without triggering an error code 84.
652				VSD Safety Loop	S	1	0-1	Sets the behavior of the VSD when the safety loop (or burner flange) is open. 0 = VSD commanded to 0% when safety loop (or burner flange) is open. 1 = VSD control is unaffected when safety loop (or burner flange) is open.
653				Speed Eval Standby		1	0-1	Determines if the speed of the VSD will be monitored during standby (phase 12). If the speed is not monitored, this parameter also has the effect of permitting the blower to freewheel to standby after postpurge is complete. 0 = speed is not monitored 1 = speed is monitored
661				PI Control	S/O	1	0-1	This setting activates or deactivates the internal PI speed controller in the LMV3. Must be set to activated if using a VFD. If using a brushless DC blower with an internal speed control, this should be deactivated. 0 = deactivated 1 = activated
662				VSD Neutral Zone		+/- 0.5%	+/- 0.5-3.5%	Sets the width of the "neutral zone" for speed control. Percentages are based on the standardized speed (parameter 642). When the speed lies within the neutral zone, the speed is considered to be in range and modulation is not paused. The neutral band has no associated timing.
663				VSD Near Zone		+/- 2%	+/- 2-5.5%	Sets the width of the "near zone" for speed control. Percentages are based on the standardized speed (parameter 642). When the speed lies outside the neutral zone, but inside the near zone, modulation is paused and a timer is started. The allowable time for the speed to reside in this zone band is set by parameter 664. Modulation will resume if the speed transitions back to the neutral zone.
664				Near Zone Time		8 sec	8-16 sec	This sets the maximum time that the motor speed can lie outside the neutral zone and in the near zone (see parameter 663) before a lockout occurs.
665				Outside Near Zone Time		3 sec	3-7 sec	This sets the maximum time that the motor speed can lie outside of the near zone (see parameter 663) but within the maximum allowable speed deviation of +/-10%. Percentages are based on the standardized speed (parameter 642). If +/- 10% speed deviation is detected, a quick shutdown will result in less than 1 second.
667				Min Speed Prepurge		Not set	40-100%	This is used to guarantee the minimum prepurge speed of the VSD is above this setting when using a gas train with pneumatic fuel-air ratio control. Do not adjust if using the LMV3 for fuel-air ratio control via parallel positioning.

Parameter #				Parameter Name	LEGEND - Password Access: U = User, S = Service, O = OEM, U/S = View - User, Write - Service, S/O = View - Service, Write - OEM Shaded Parameters = Frequently Used. ** Parameters = Must Set. Fuel 1 parameters for LMV36 only.			
Fuel 0		Fuel 1			U/S/O	Default	Range	Description
Gas	Oil	Gas	Oil					
668				Max Speed Ignition	S/O	Not set	20-75%	This is used to guarantee the maximum ignition speed of the VSD is below this setting when using a gas train with pneumatic fuel-air ratio control. Do not adjust if using the LMV3 for fuel-air ratio control via parallel positioning.
669				Speed Range Operation		00 = Not set 01 = Not set	10-100%	When using a gas train with pneumatic fuel-air ratio control, this defines the minimum and maximum allowable VSD speeds when the burner is firing. Do not adjust if using the LMV3 for fuel-air ratio control via parallel positioning. Index 00 = minimum speed. Index 01 = maximum speed
670				VSD Speed PS Off		50%	20-90%	If a second air pressure switch is used on terminal X5-02.2 (see parameter 237/337), this parameter sets the VSD speed below which this pressure switch is expected to be open (off).
671				VSD Speed PS On		80%	45-100%	If a second air pressure switch is used on terminal X5-02.2 (see parameter 237/337), this parameter sets the VSD speed above which this pressure switch is expected to be closed (on).
700 Level: Fault History								
701-725				Fault History	U	Read only		Shows the current status (fault) along with the 24 most recent faults. 701 = current status, 702 = most recent fault, 703 = next most recent fault, etc. Each fault has indices that provide additional information about the fault: Index 01 = code Index 02 = diagnostic Index 03 = class (not used in North America) Index 04 = phase Index 05 = start number Index 06 = load Index 07 = fuel (LMV36 only)
900 Level: Operational Data								
903				Actual Load	S	Read only		Displays the real time load percentage. Index 00 (fuel load) and 01 (air load) show identical values.
916				Analog Speed Shift				Displays the real time mA signal being measured on terminal X64 as a percentage. The percentage is always scaled as follows: -15% = 4 mA, 0% = 10 mA, 25% = 20 mA.
917				Target Speed Shift				Displays the real time target of the VSD speed shift as a percentage of standardized speed, with shift limits and shift attenuation applied.
918				Actual Shift				Displays the real time actual VSD speed shift as a percentage of the standardized speed.
922				Actual Position	U			Displays the current position of the actuators in degrees. Index 00 = fuel actuator. Index 01 = air actuator
932				Target Speed	S			Displays the real time target speed for the VSD with all shifts and attenuations applied. Displayed as a percentage of the standardized speed.

Parameter #				Parameter Name	LEGEND - Password Access: U = User, S = Service, O = OEM, U/S = View - User, Write - Service, S/O = View - Service, Write - OEM Shaded Parameters = Frequently Used. ** Parameters = Must Set. Fuel 1 parameters for LMV36 only.			Description
Fuel 0		Fuel 1			U/S/O	Default	Range	
Gas	Oil	Gas	Oil					
933				Speed Delta	S	Read only	Displays the real time difference between the target speed (in %) and the actual speed (in %). Used to observe the accuracy of the VSD speed control through the operating range.	
935				Actual Speed RPM			Displays the real time speed of the VSD. Displayed in RPM.	
936				Actual Speed %	U		Displays the real time speed of the VSD. Displayed as a percentage of the standardized speed.	
942				Active Load Source	S		This setting displays the active load source. There are five ways of sending a load command to the LMV3. If multiple commands are received at the same time, the LMV3 uses the following priorities to determine which command to follow: 1 = setting the fuel-air ratio curve (via parameter 400) 2 = manual mode (enabled during operation or via parameter 121) 3 = Modbus command on terminal X92 4 = 4-20 mA signal on terminal X64 5 = 3-position signal on terminals X5-03.2 and X5-03.3 (LMV37 only)	
945				Current Fuel	U		Parameter only exists on an LMV36: Displays the current fuel selected (0 or 1).	
947				Input Status	S		Displays the status of the inputs (index 00) and outputs (index 01) with a bit-coded total.	
948				Input Count			Contact feedback network counter register.	
950				Output Status			Displays the required state of the output relays with a bit-coded total.	
951				Incoming Voltage			Displays the real time mains voltage. For 120 VAC power, multiply the displayed value by 0.843. For 230 VAC power, multiple the displayed value by 1.683. Measured at terminal X3-04 pin 4 and pin 5.	
954				Flame Signal	U		Displays the raw flame signal from 0-100% for any flame scanner type. A flame failure occurs when the flame signal drops below 24% for the time period specified by parameter 186 (fuel 0) or 187 (fuel 1). This signal refers to input terminal X10-06 (UV scanners) or input terminal X10-05.2 (flame rods).	
960				Actual Fuel Flow			Displays the real time fuel flow.	
961				Actual Phase	S		Displays the real time phase of the LMV3.	
981				Actual Fault			Displays the real time fault code.	
982				Actual Diagnostic			Displays the real time fault diagnostic.	
992				Fault Number			Reset only	Displays the total number of fault flags. This value can be reset by pressing the left or right arrow to change the value to 00000000 and then pressing Enter.

Sequence Diagrams

The Siemens LMV3 BMS can perform a number of different burner sequences based upon how certain parameters are set. Although there are a number of parameters that affect small aspects of the burner sequence, the main parameters that affect the sequence are parameters **201** and **301**.

These parameters set the framework of the sequence and are based upon the fuel train diagrams in Section 4. The OEM has the option of selecting one of fourteen different gas trains with their associated sequence diagrams, and one of fifteen different oil trains with their associated sequence diagrams.

The sequence diagrams illustrate when input and output terminals are expected to be energized or de-energized. A legend on the bottom of each page describes the various symbols used in the diagrams. The last diagram describes what positions the attached actuators are expected to achieve at each phase and outlines the method that is used to check the actuators position.





Notes:

- 1) If parameter 235/335 is set to 2, air pressure switch input X3-02.1 can be de-energized in phases 60-66 without an alarm. This is only allowed on pneumatic fuel trains.
- 2) After the main valves open, the high and low pressure switch inputs are ignored for the length of time specified by parameter 229/269/329/369. This is done so that pressure shocks do not cause erroneous alarms on properly adjusted automatic reset pressure switches.
- 3) Parameter 237/277/337/377 sets the function of input X5-02.2.
- 4) Parameter 210 determines if the alarm output will energize in the event of a start prevention (an alarm in standby). If set to 1 (activated), the LMV3 will wait 5 seconds after receiving a call for heat before going into alarm.
- 5) Parameter 276/376 defines the phase when the low oil pressure switch input X9-04.2 must be energized. A setting of 1 means the input must be energized in phase 38 (parameter 217 sets the length of time after the beginning of phase 38 that the input must be energized). A setting of 2 means the input must be energized by the beginning of safety time 1 (phase 40).

-
- 6) On direct ignition oil trains, parameter 281/381 determines the point at which the oil is ignited during the startup sequence. A setting of 0 means the ignition output X4-02.3 will energize at the beginning of phase 38. A setting of 1 means the ignition output X4-02.3 will energize at the beginning of phase 22.
 - 7) On heavy oil trains, parameter 286 defines the point in the startup sequence when the start release for heavy oil (input X9-04.2) must be energized. A setting of 0 means the input only needs to be energized during phase 38. A setting of 1 means the input must be energized during phases 38-62.
 - 8) If gas valve proving is performed on startup (immediately after phase 30), the actuators will be in prepurge position. If gas valve proving is performed on shutdown (immediately after phase 62), the actuators will be in the same position as they were in phase 62. The actuators will not move during valve proving.
 - 9) Actuator position is checked by using one of three methods. The method used depends upon the phase of the sequence. *Position Required to Proceed* means that the actuators must achieve and hold a certain position for the sequence to proceed. *Dynamic Position Checking* means that the actuator is evaluated by a “time and distance from target” algorithm. The further the actuator is away from its target position, the less time the actuator is permitted to be in that position. *Run-Time Position Checking* means that the actuator is expected to be at a certain point in a certain amount of time (based off of the run-time of the actuator).

Parameter 208 (Program Stop)			PS		PS		PS																						
Gas Train: 1, 7, 14, 19, 28 (Direct Ignition)			Lockout Phase	Safety Phase	Home Run Position	Burner Standby	Combustion Fan, Safety Valve = ON	Drive to Prepurge Position	Prepurge	VSD Drive to Ignition Position	Drive to Ignition Position	Preignition (Spark) = ON	Main Valve = ON	Ignition (Spark) = OFF	Interval 1 (Main Stabilization)	Operation 1 (Normal Operation)	Operation 2 (Driving to Low Fire)	Afterburn Time	Drive to Postpurge Position	Mandatory Postpurge	Optional Postpurge	Phase	80	81	82	83	90		
			00	02	10	12	22	24	30	35	36	38	40	42	44	60	62	70	72	74	78	GAS VALVE PROVING							
			START-UP												OPERATION		SHUTDOWN												
Terminal	Description	Notes													SAFETY TIME 1														
INPUTS	X3-04.1	Safety Loop (Limits)				M																							
	X5-03.1	On / Off Switch				M																							
	N/A	Flame Signal			X	X			X					M					F					X		X	X	X	
	X3-02.1	Blower Air Switch (APS)	Note 1			F	X		M																				
	X5-01.2	Low Gas Pressure Switch	Note 2																										
	X5-02.2	High Gas Pressure Switch POC	Note 2, 3 Note 3													F	X			M									
X9-04.2	Valve Proving Pressure Switch																												
OUTPUTS	X3-05.1	Fan	X	X	X	X																						X	
	X3-05.3	Continuous Fan																											
	X4-02.3	Ignition		X	X	X	X	X	X	X				X	X	X	X			X	X	X	X					X	
	X3-05.2	Alarm	Note 4		X	X			X	X	X									X	X	X	X					X	
	X6-03.3	Gas Valve SV (Usually Outdoor)		X	X	X	X																					X	
	X8-02.1	Gas Valve V1 (Main, Upstream)		X	X	X	X	X	X	X										X	X	X	X					X	
	X7-01.3	Gas Valve V2 (Main, Downstream)		X	X	X	X	X	X	X										X	X	X	X					X	

Legend :

	Energized		Must be energized by end of phase
	Energized or de-energized		Must be de-energized by end of phase
	De-energized		

Parameter 208 (Program Stop)

**Gas Train:
3, 9, 16, 21, 29
(Pilot Gp2)**

			00	02	10	12	22	24	30	35	36	38	40	42	44	50	52	60	62	64	65	66	67	68	69	70	72	74	78	80	81	82	83	90				
			Lockout Phase	Safety Phase	Home Run Position	Burner Standby	Comb. Fan, SV = ON	Drive to Prepurge Pos.	Prepurge	VSD Drive to Ignition Pos.	Drive to Ignition Pos.	Preignition (Spark) = ON	Pilot Valve = ON	Ignition (Spark) = OFF	(Pilot Stabilization)	Safety Time 2	Interval 2 (Main Stabilization)	Operation 1 (Normal Operation)	Operation 2 (Driving to Low Fire)	Drive to Ignition Pos.	Interval 2	Ignition (Spark) + Pilot Valve = ON	Main Valve = OFF	Pilot Waiting Time	Pilot Waiting Time - Startup (Interval 1)	Afterburn Time	Drive to Postpurge Pos.	Mandatory Postpurge	Optional Postpurge	Pressure Test	Fill	Atmospheric Test	Evacuate	Gas Shortage				
			Phase																																			
			START-UP													OPERATION				REVERT TO PILOT				SHUTDOWN				GAS VALVE PROVING										
Terminal	Description	Notes	SAFETY TIME 1																																			
INPUTS	X3-04.1	Safety Loop (Limits)				M																																
	X5-03.1	On / Off Switch				M																																
	N/A	Flame Signal				X	X		X																													
	X3-02.1	Blower Air Switch (APS)	Note 1			F	X		M																													
	X5-01.2	Low Gas Pressure Switch	Note 2																																			
OUTPUTS	X5-02.2	High Gas Pressure Switch	Note 2, 3																																			
	X9-04.2	Valve Proving Pressure Switch	Note 3																																			
	X3-05.1	Fan		X	X	X	X																															X
	X3-05.3	Continuous Fan																																				
	X4-02.3	Ignition		X	X	X	X	X	X	X																												X
	X3-05.2	Alarm	Note 4	X	X	X	X	X	X	X																												X
	X6-03.3	Gas Valve SV (Usually Outdoor)		X	X	X	X	X	X	X																												X
	X7-02.3	Gas Valve PV (Pilot Valve)		X	X	X	X	X	X	X																												X
X8-02.1	Gas Valve V1 (Main, Upstream)		X	X	X	X	X	X	X																												X	
X7-01.3	Gas Valve V2 (Main, Downstream)		X	X	X	X	X	X	X																												X	

Legend : Energized M Must be energized by end of phase
 Energized or de-energized F Must be de-energized by end of phase
X De-energized

Parameter 208 (Program Stop)							PS			PS				PS								
<p style="text-align: center;">Oil Train: 4, 5, 6, 12, 17, 18, 22 (Light Oil LO)</p>			Lockout Phase	Safety Phase	Home Run Position	Burner Standby	Combustion Fan, Safety Valve = ON	Drive to Prepurge Position	Purge	VSD Drive to Ignition Position	Drive to Ignition Position	Preignition (Spark) = ON	Main Valve = ON	Ignition (Spark) = OFF	Interval 1 (Main Stabilization)	Operation 1 (Normal Operation)	Operation 2 (Driving to Low Fire)	Afterburn Time	Drive to Postpurge Position	Mandatory Postpurge	Optional Postpurge	
			Phase	00	02	10	12	22	24	30	35	36	38	40	42	44	60	62	70	72	74	78
			START-UP												OPERATION		SHUTDOWN					
Terminal	Description	Notes												SAFETY TIME 1								
INPUTS	X3-04.1	Safety Loop (Limits)				M																
	X5-03.1	On / Off Switch				M																
	N/A	Flame Signal			X	X			X	X	X			M					F			X
	X3-02.1	Blower Air Switch (APS)	Note 1			F	X		M													
	X5-02.2	High Oil Pressure Switch	Note 2, 3																			
		POC	Note 3													F	X			M		
X9-04.2	Low Oil Pressure Switch	Note 5																				
OUTPUTS	X3-05.1	Fan		X	X	X	X															
	X3-05.3	Continuous Fan																				
	X4-02.3	Ignition	Note 6	X	X	X	X	See Note 6							X	X	X	X	X	X	X	X
	X3-05.2	Alarm	Note 4		X	X		X	X	X	X	X	X	X	X	X	X	X	X	X	X	X
	X6-03.3	Oil Valve SV (Usually Outdoor)		X	X	X	X															
	X8-02.1	Oil Valve V1 (Main)		X	X	X	X	X	X	X	X	X							X	X	X	X
	X7-01.3	Oil Valve V2 (Staged, Load Dependent)		X	X	X	X	X	X	X	X	X	X	X	X		X	X	X	X	X	X
X7-02.3	Oil Valve V3 (Staged, Load Dependent)		X	X	X	X	X	X	X	X	X	X	X	X		X	X	X	X	X	X	

Legend :

	Energized	M	Must be energized by end of phase
	Energized or de-energized	F	Must be de-energized by end of phase
X	De-energized		

Intentionally Left Blank

Section 1	Overview
Section 2	Wiring
Section 3	Parameters
Section 4	Commissioning
Section 5	VSD
Section 6	Troubleshooting
Section 7	Modbus
Section 8	ACS410
Appendix A	Application Guide

Section 1	Overview
Section 2	Wiring
Section 3	Parameters
Section 4	Commissioning
Section 5	VSD
Section 6	Troubleshooting
Section 7	Modbus
Section 8	ACS410
Appendix A	Application Guide

Section 4: Commissioning

Table of Contents

Pre-Requisites for Basic LMV3 Systems.....	2
Pre-Requisites for LMV3 Systems with a VSD.....	4
Configuring (Parameterization of) an LMV3 with a Default Parameter Set.....	5
Transferring Parameter Sets Using the AZL Display	17
Suggested Initial Light-off for LMV3 Systems.....	18
Suggested Ratio Control Curve Commissioning.....	19
Additional Tips for Commissioning.....	23

Before the LMV3 can be commissioned, certain pre-requisites must be met for the LMV3 control, the burner, the boiler, and the boiler room. Experience has shown that if the points below are addressed properly, commissioning will be safe, timely, and trouble-free.

Pre-Requisites for Basic LMV3 Systems

1. Burner / boiler must be in "good" condition. Burner firing head must be correct for the boiler and the firing head must not be cracked, melted, or otherwise damaged. Other items to check include:
 - a. Flame scanner tube must sight pilot and main flame correctly.
 - b. Refractory should not interfere with the flame scanner sighting or the flame path of the burner.
 - c. For fire tube boilers, the flame should not impinge on the Morrison tube.
2. All LMV3 components (base unit, actuators, flame scanners, etc.) are mounted properly. Particular attention should be paid to the following:
 - a. Actuator shaft couplings must accomplish the following:
 - i. Compensate for both angular and parallel shaft misalignment generated by the mounting bracket.
 - ii. Have little or no backlash.
 - iii. Be robust enough to absorb the stall torque of the actuator without damage.

Solid (rigid) shaft couplings are not acceptable in most applications. Clamp-type couplings that have a D-shape are preferred since these will not damage the actuator shaft and do provide positive engagement. In linkage-less applications, actuator couplings should be considered to be safety-related components.

NOTE: Do not couple actuator to valve / damper shaft until the direction of rotation for the actuator is set, and the LMV3 alarm is reset. This is outlined later in the commissioning section.

- b. Actuator brackets must be rigid enough so that they do not amplify burner vibration (diving board effect) or distort significantly when the actuator is applying maximum torque to the valve / damper shaft.
- c. When actuator is installed and coupled, ensure that all mounting hardware is tightened adequately, and some method of thread locking is employed on the mounting hardware (except for the coupling hardware).

- d. Ensure environmental conditions (temperature, vibration, moisture, etc.) are not exceeded.
3. Ensure that all wiring is per the applicable wiring diagram and also meets applicable local and national codes. Particular attention should be paid to the following:
 - a. If a step-down control transformer is the source of 120 VAC power for the LMV3, the ground and neutral should be bonded (connected) on the transformer.
 - b. Voltage supply to a 120 VAC LMV3 must be between 102 and 132 VAC, 47-63 Hz. Waveform must be a full sine wave.
4. Fuel (gas) supply must be adequate to support high fire operation and fuel (gas) train must be sized correctly.
 - a. Fuel (gas) pressure before the firing rate control valve must be correct, stable and repeatable at all firing rates and must not vary when other fuel (gas) burning appliances (other boilers in the building) are being operated.
 - b. The fuel (gas) pressure regulator on the burner being commissioned should not be fully open at high fire and should not be bouncing off the seat at low fire. Fuel regulator must be sized properly, and have adequate turndown capability.
5. A temporary stack gas analyzer that has been calibrated and at a minimum reads O₂ (%) and CO (ppm) must be used for setting combustion.
6. Knowledge of what fuel flow represents high fire of the burner / boiler combination and also the turndown of the burner / boiler combination. This can typically be found on the burner / boiler nameplate.
7. A method of determining firing rate (fuel flow within +/- 5%) should be used. This, in combination with knowledge of high fire and turndown, is used to set the fuel flow on each curve point. An Excel spreadsheet is available for this purpose.
8. For steam boilers, the feedwater supply must be adequate to support high fire operation. Feedwater controls must be working properly.
9. The load on the boiler must be adequate so that a burner / boiler combination can be run at high fire for a minimum of 5 minutes.

Pre-Requisites for LMV3 Systems with a VSD

1. All pre-requisites of the Basic LMV3 system apply.
2. For VFD equipped burners, the blower motor speed sensor and speed wheel must be installed correctly.
3. Proper grounding between the LMV3, the VSD, and the motor must be installed. See Section 2 (Wiring) for more details.
4. For VFD equipped burners, VFD parameters must be set correctly to be compatible with both the LMV3 and the blower motor. See Section 5 (VSD) for more details. Particular attention should be paid to the following:
 - a. Analog signal configuration. Both the LMV3 and VFD must be configured for a 0-10 VDC signal.
 - b. Ramp rates between the LMV3 and the VFD must be compatible. In general, ramp rates of the VFD should be 10 seconds less than the LMV3.
 - c. VFD must be set up as a slave unit for a 0-10 VDC signal. Damping, dead band, and PID functions must be disabled.
 - d. The frequency (Hz) output of the drive must be directly proportional to the analog input signal.
 - e. Acceleration / deceleration curves must be linear instead of "S-shaped".
 - f. Ramp settings must be ramp up / ramp down instead of ramp up / coast down.
 - g. Any type of damping or stall prevention in the VFD should be deactivated.
5. LMV3 / VSD combination must be "Standardized" before operation. See Section 5 (VSD) for more details.
 - a. Verify that the air damper opens to pre-purge position before the blower is energized for standardization.

Configuring (Parameterization of) an LMV3 with a Default Parameter Set

The procedure below assumes an LMV3 with a default parameter set. If the LMV3 is mounted to a burner / boiler, the OEM(s) may have already changed the parameters from the default setting and parameterized the LMV3 for the application.

Section 3 (Parameters) gives a detailed explanation of all of the parameters in the LMV3, as well as highlights which parameters must be set (marked with a double asterisk **) and which parameters are frequently used (shaded).

This procedure gives a general guideline of what parameters need to be set to get an LMV3 running on a typical burner / boiler. Every burner is different, so it is likely that every burner will need a somewhat unique parameter set to run correctly.

When an LMV3 with a default parameter set is powered up and wired correctly, it will state "OFF UPr". This means that the unit is in standby, and has not yet been fully commissioned.

1. Log in at the OEM password level. To do so, hold down the F and A buttons together until "CodE" is displayed. Type in the OEM password and press Enter to log in. From the factory, the OEM password for the LMV3 is "EntrY".
2. Set the Burner ID via parameter 113. The Burner ID is a unique number which matches the burner to the parameter set in the LMV3. Typically, the serial number of the burner is used as the Burner ID.
3. Set the fuel train(s) via parameter 201 (fuel 0) and parameter 301 (fuel 1 – LMV36 only). Both fuel 0 and fuel 1 may be set for either a gas train or an oil train, so it is possible to be programmed for two gas trains, two oil trains, or one gas train and one oil train on an LMV36. See pages 6-13 for fuel train information. This procedure is continued on page 14. Option 3 (Gp2 mod) is typical for gas piloted gas burners and option 10 (Lo Gp mod) is typical for gas piloted oil burners.

NOTE: Heavy oil fuel trains (options 23-27) are not discussed in this document. If assistance is required on a heavy oil fuel train, contact SCC Inc.

Modulating Gas - Direct Spark Ignition

(Fuel Train Options 1, 7, 14, 19, 28)

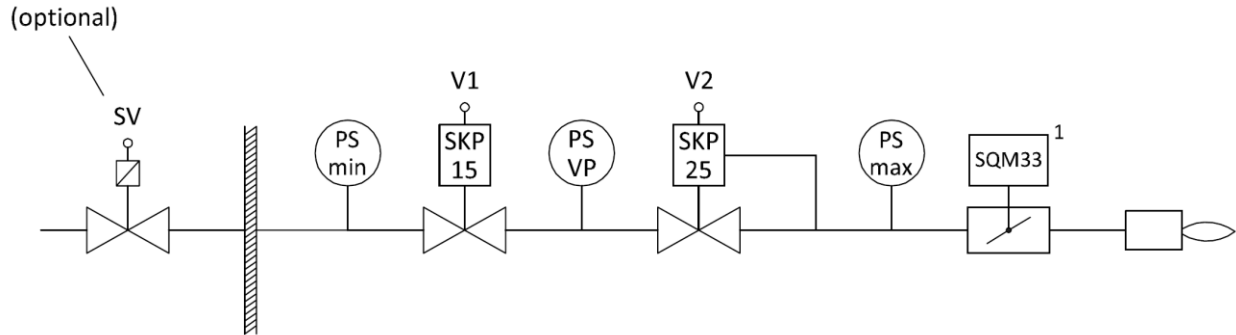

Legend:

- | | |
|--|----------------------------------|
| SV = Safety valve (optional, outside building) | V1 = Upstream gas valve (main) |
| PS = Pressure switch | V2 = Downstream gas valve (main) |
| VP = Valve proving | |

Notes:

1. Fuel actuator not used with options 7, 14, or 28
2. A single shutoff valve can be used where allowed by code
3. The SKP25 (on valve V2) is typically replaced by an SKP55/75 for pneumatically linked gas trains

Operating Mode Parameter 201 (fuel 0) or 301 (fuel 1)	Fuel Train	Fuel Actuator	Air Actuator	VSD Speed Feedback (if activated)	Description
1	G mod	•	•	•	Modulating gas, direct ignition, electronically linked fuel-to-air ratio
7	G mod pneu		•		Modulating gas, direct ignition, pneumatically linked fuel-to-air ratio
14	G mod pneu				Modulating gas, direct ignition, pneumatically linked fuel-to-air ratio, no actuators
19	G mod	•		•	Modulating gas, direct ignition, electronically linked fuel-to-air ratio
28	G mod mech		•	•	Modulating gas, direct ignition, mechanically linked fuel-to-air ratio

Modulating Gas - Pilot Ignition 1 (Pilot between V1 and V2)

(Fuel Train Options 2, 8, 15, 20)

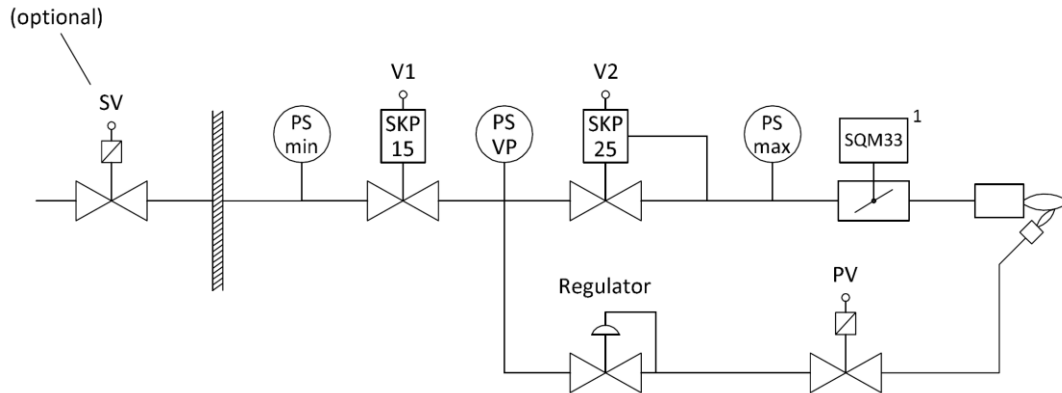

Legend:

- | | |
|--|----------------------------------|
| SV = Safety valve (optional, outside building) | V1 = Upstream gas valve (main) |
| PS = Pressure switch | V2 = Downstream gas valve (main) |
| VP = Valve proving | PV = Pilot valve |

Notes:

1. Fuel actuator not used with options 8 or 15
2. The SKP25 (on valve V2) is typically replaced by an SKP55/75 for pneumatically linked gas trains

Operating Mode Parameter 201 (fuel 0) or 301 (fuel 1)	Fuel Train	Actuator		VSD Speed Feedback (if activated)	Description
		Fuel Actuator	Air Actuator		
2	Gp1 mod	•	•	•	Modulating gas, pilot ignition 1 (pilot between V1 and V2), electronically linked fuel-to-air ratio
8	Gp1 mod pneu		•		Modulating gas, pilot ignition 1 (pilot between V1 and V2), pneumatically linked fuel-to-air ratio
15	Gp1 mod pneu				Modulating gas, pilot ignition 1 (pilot between V1 and V2), pneumatically linked fuel-to-air ratio, no actuators
20	Gp1 mod	•		•	Modulating gas, pilot ignition 1 (pilot between V1 and V2), electronically linked fuel-to-air ratio

Modulating Gas - Pilot Ignition 2 (Pilot before V1 and V2)

(Fuel Train Options 3, 9, 16, 21, 29)

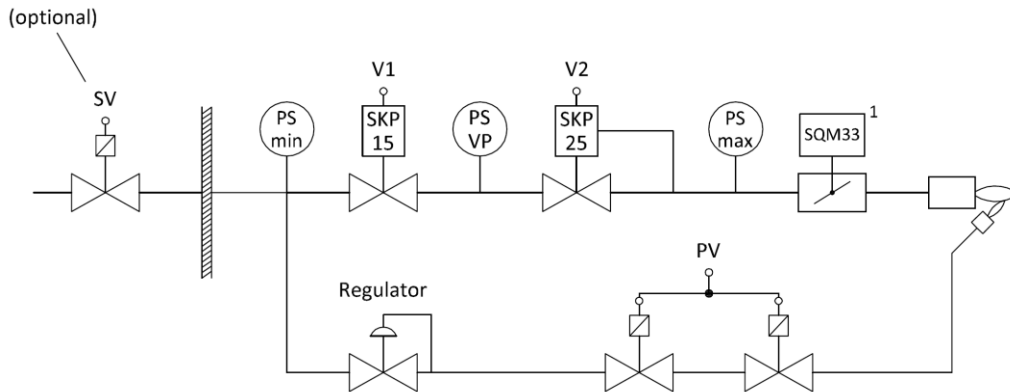

Legend:

- | | |
|--|----------------------------------|
| SV = Safety valve (optional, outside building) | V1 = Upstream gas valve (main) |
| PS = Pressure switch | V2 = Downstream gas valve (main) |
| VP = Valve proving | PV = Pilot valve |

Notes:

- Fuel actuator not used with options 9, 16, or 29
- A single shutoff valve can be used where allowed by code
- The SKP25 (on valve V2) is typically replaced by an SKP55/75 for pneumatically linked gas trains

Operating Mode Parameter 201 (fuel 0) or 301 (fuel 1)	Fuel Train	Fuel Actuator	Air Actuator	VSD Speed Feedback (if activated)	Description
3	Gp2 mod	•	•	•	Modulating gas, pilot ignition 2 (pilot before V1 and V2), electronically linked fuel-to-air ratio
9	Gp2 mod pneu		•		Modulating gas, pilot ignition 2 (pilot before V1 and V2), pneumatically linked fuel-to-air ratio
16	Gp2 mod pneu				Modulating gas, pilot ignition 2 (pilot before V1 and V2), pneumatically linked fuel-to-air ratio, no actuators
21	Gp2 mod	•		•	Modulating gas, pilot ignition 2 (pilot before V1 and V2), electronically linked fuel-to-air ratio
29	Gp2 mod mech		•	•	Modulating gas, pilot ignition 2 (pilot before V1 and V2), mechanically linked fuel-to-air ratio

Modulating Light Oil - Direct Spark Ignition

(Fuel Train Options 4, 12, 22)

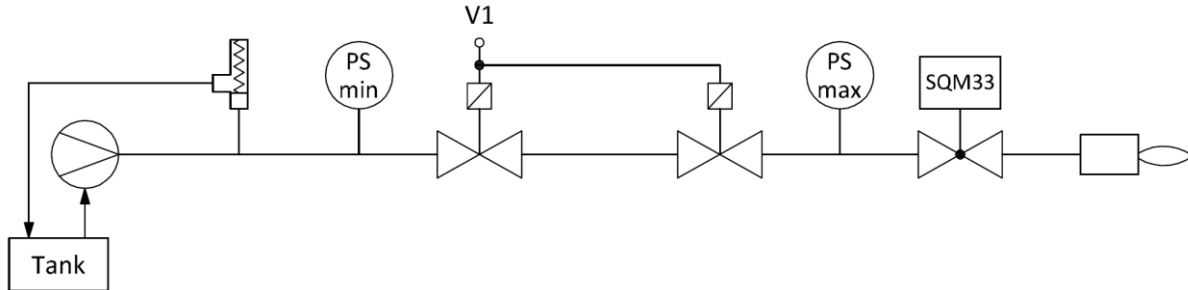

Legend:

PS = Pressure switch

V1 = Oil valve (main)

V2 = Stage 2 oil valve

Operating Mode Parameter 201 (fuel 0) or 301 (fuel 1)	Fuel Train	Fuel Actuator	Air Actuator	VSD Speed Feedback (if activated)	Description
4	Lo mod	•	•	•	Modulating light oil, direct ignition, electronically linked fuel-to-air ratio
12	Lo mod 2V	•	•	•	Modulating light oil, direct ignition, electronically linked fuel-to-air ratio (OEM specific)
22	Lo mod	•		•	Modulating light oil, direct ignition, electronically linked fuel-to-air ratio

2-stage Light Oil - Direct Spark Ignition

(Fuel Train Options 5, 17)

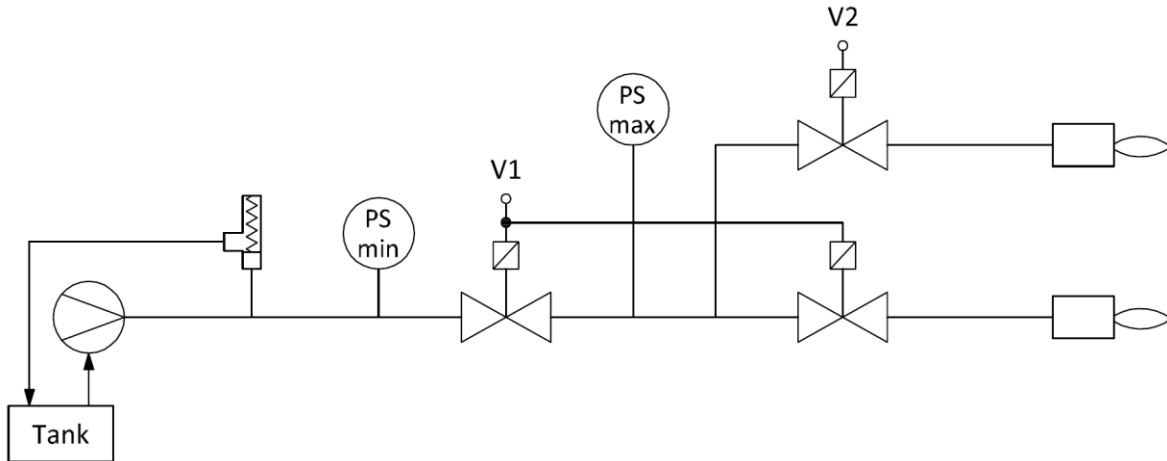

Legend:

PS = Pressure switch

V1 = Oil valve (main)

V2 = Stage 2 oil valve

Operating Mode Parameter 201 (fuel 0) or 301 (fuel 1)	Fuel Train	Fuel Actuator	Air Actuator	VSD Speed Feedback (if activated)	Description
5	Lo 2-stage		•	•	2-stage light oil, direct ignition, electronically linked fuel-to-air ratio
17	Lo 2-stage			•	2-stage light oil, direct ignition, electronically linked fuel-to-air ratio, without actuators

3-stage Light Oil - Direct Spark Ignition

(Fuel Train Options 6, 18)

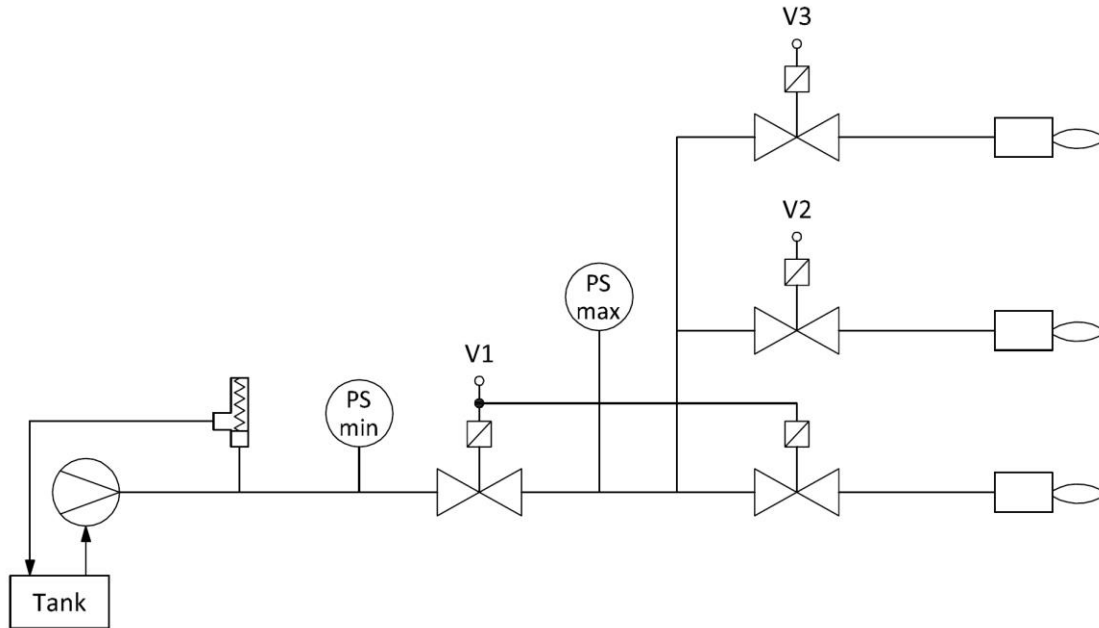

Legend:

- PS = Pressure switch
- V1 = Oil valve (main)
- V2 = Stage 2 oil valve
- V3 = Stage 3 oil valve

Operating Mode Parameter 201 (fuel 0) or 301 (fuel 1)	Fuel Train	Fuel Actuator	Air Actuator	VSD Speed Feedback (if activated)	Description
6	Lo 3-stage		•	•	3-stage light oil, direct ignition, electronically linked fuel-to-air ratio
18	Lo 3-stage			•	3-stage light oil, direct ignition, electronically linked fuel-to-air ratio, without actuators

Modulating Light Oil - Gas Pilot

(Fuel Train Options 10, 13)

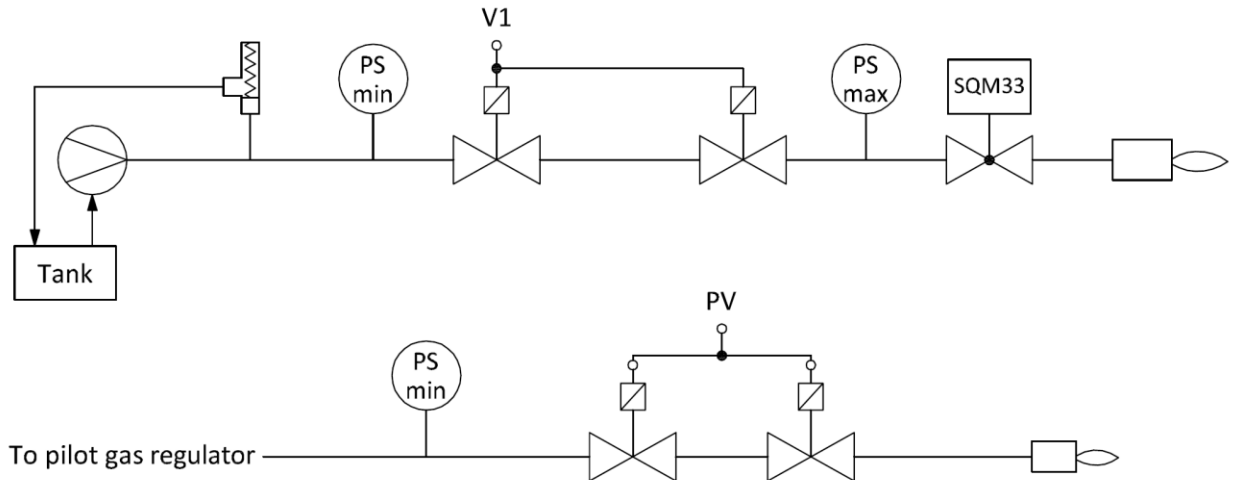

Legend:

PS = Pressure switch

V1 = Oil valve (main)

V2 = Stage 2 oil valve

Operating Mode Parameter 201 (fuel 0) or 301 (fuel 1)	Fuel Train	Fuel Actuator	Air Actuator	VSD Speed Feedback (if activated)	Description
10	Lo Gp mod	•	•	•	Modulating light oil, gas pilot ignition, electronically linked fuel-to-air ratio
13	Lo Gp mod 2V	•	•	•	Modulating light oil, gas pilot ignition, electronically linked fuel-to-air ratio (OEM specific)

2-stage Light Oil - Gas Pilot

(Fuel Train Option 11)

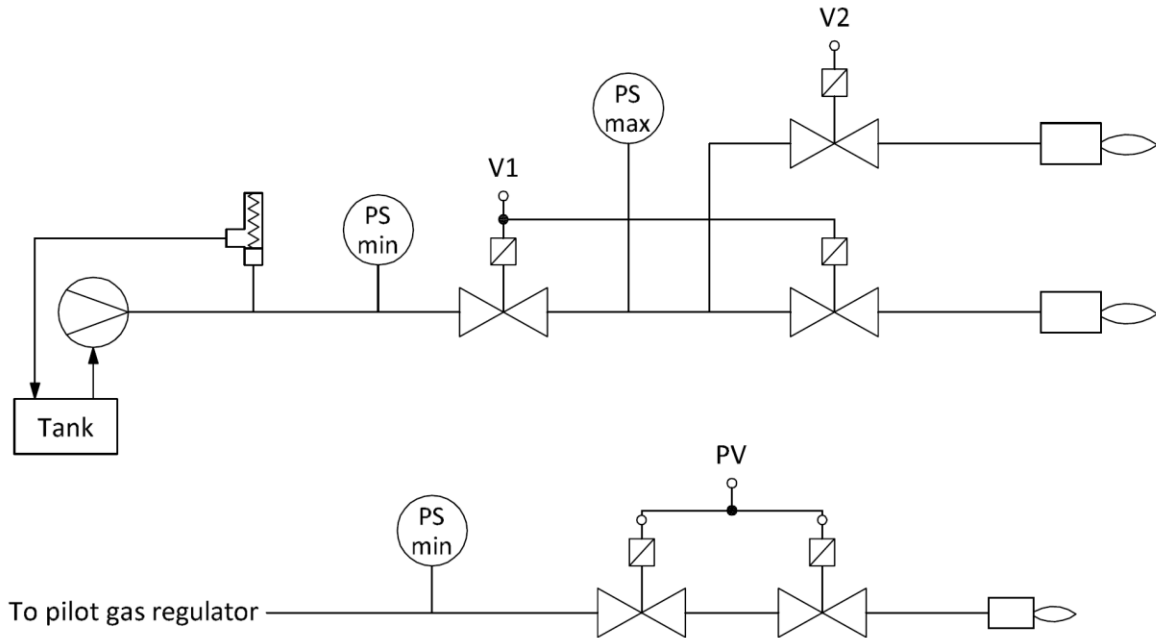

Legend:

PS = Pressure switch

V1 = Oil valve (main)

V2 = Stage 2 oil valve

Operating Mode Parameter 201 (fuel 0) or 301 (fuel 1)	Fuel Train	Fuel Actuator	Air Actuator	VSD Speed Feedback (if activated)	Description
11	Lo Gp 2-stage		•	•	2-stage light oil, gas pilot ignition, electronically linked fuel-to-air ratio

4. If a VSD is being used, activate it by setting parameter 542 to 1. Otherwise, leave parameter 542 set to 0.

NOTE: Depending on the direction of rotation and home position set in the LMV3, the actuator may rotate as soon as the fuel train is selected. For this reason, it is highly recommended that the actuator shaft be uncoupled from the valve / damper until the parameters pertaining to the direction of rotation and home position are set.

5. For each actuator connected, set the direction of rotation via parameters 602 and 609.

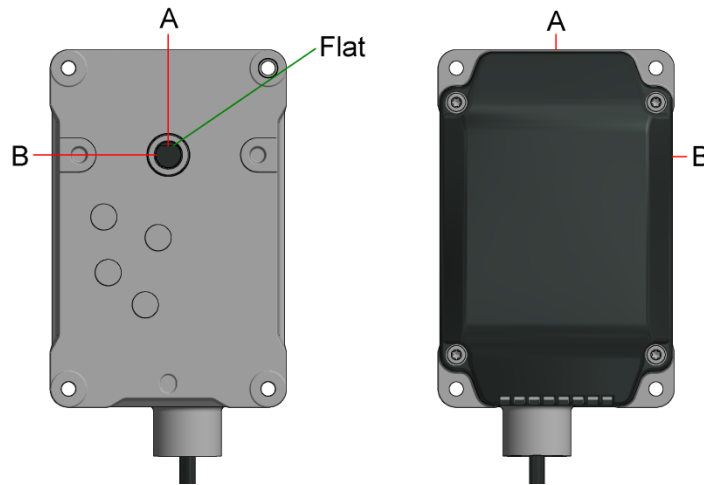

Figure 4-3: Counterclockwise vs. Clockwise Rotation

- a. **Counterclockwise Rotation** - Flat is perpendicular to line **A** when indicated actuator position is at 0°. Flat will be perpendicular to line **B** when indicated actuator position is 90°. This is how the actuator's shaft comes from the factory.
 - b. **Clockwise Rotation** - Flat is perpendicular to line **B** when indicated actuator position is at 0°. Flat will be perpendicular to line **A** when indicated actuator position is 90°.
6. Set actuator home (standby) positions if necessary via parameters 501-506. Defaults are 0° and 0% VSD. For dual fuel burners this will need to be done for both fuels.
 7. Set the actuator reference direction. All SQM33... actuators have a range of motion from 0-90° during operation. However, before every startup, each actuator connected must rotate the shaft to either a position less than 0° or a position greater than 90° to reference the actuator shaft position. Rotating to a position less than 0° is called referencing on the “closed” side. Rotating to a position greater than 90° is called referencing on the “open” side. See Figure 4-4 for more details.

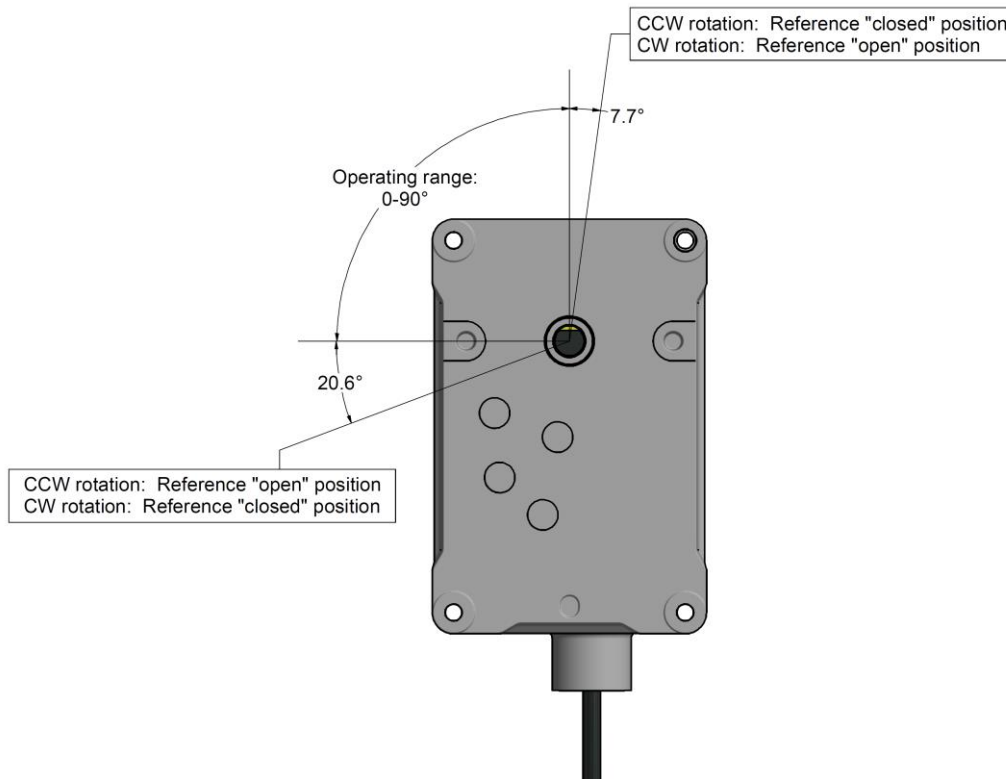

Figure 4-4: Referencing "Closed" vs. Referencing "Open"

For example, if an actuator was selected to have a counterclockwise rotation and is referencing on the "open" side, the actuator will drive 20.6° past the open (90°) position before each startup.

Most valves / dampers can rotate past the open (90°) position, so it is common to set all actuator referencing directions to "open".

NOTE: Valves / dampers must not torque against mechanical stops during referencing.

- Couple actuators to the valves / dampers. Actuators must not torque against mechanical stops on the valve / damper when at home position. Adjust home positions if necessary.

NOTE: Actuator shaft couplings must compensate for both angular and parallel shaft misalignment due to the mounting bracket. Solid (rigid) shaft couplings are not acceptable in most applications, especially when formed or welded mounting brackets are used. Couplings should have little to no backlash, and are a safety relevant part of a linkage-less system.

NOTE: Make absolutely certain that when the actuators are at or near 0° (as indicated on the AZL display) that the valve / damper the actuator is coupled to is in the CLOSED (minimum flow) position. An exception to this is some back-flow type oil burners, where a wide open oil valve will result in minimal flow through the oil nozzle.

-
9. With the burner off, stroke each valve / damper through its intended range of motion using the SQM33... actuator that is now coupled to the valve / damper. This can be achieved by changing the home positions of each actuator via parameters 501-506.

Verify that no binding will occur through the intended range of motion. Also note valves / dampers where the fully open position is less than 90°. Once the full range of motion of the valve / damper has been tested, set the home positions back to their intended settings.

10. Set the pre-purge and post-purge positions for all connected actuators via parameters 501-506. For dual fuel burners this will need to be done for both fuels.
11. If the burner has a Variable Speed Drive (VSD) on the blower, it must be standardized. If the burner is equipped with a VFD, see Section 5 in this literature if the VFD parameters are not already set, and for a more detailed standardization procedure. PWM blowers are typically pre-programmed and do not require any additional programmed. Once the VSD parameters are set, standardize the VSD via parameter 641.

Once parameter 641 is set to 1, the air damper should open to its pre-purge position, and the blower should ramp up, pause, and then ramp back down. If the value of parameter 641 changes back to 0, standardization was completed successfully. If the value changes to a negative number, see error code 82 for the cause of the failure.

NOTE: Standardization will not occur if the safety loop is open. Make sure the safety loop is closed before attempting standardization.

12. At this point, all other LMV3 parameters should be reviewed and set accordingly for the individual burner requirements.

Section 3 of this literature explains every parameter in detail, and the most commonly used parameters are shaded for easy reference.

Transferring Parameter Sets Using the AZL Display

This procedure will detail how to transfer a parameter set from one burner to another burner. In this example, the parameter set will originate from Burner #1 (B1) and will be copied to Burner #2 (B2). Naturally, using a similar procedure, the parameter set from Burner #1 can be copied to Burners #3, #4, #5, etc. The ACS410 PC software can also be used for this purpose (see Section 8).

Note: Passwords are transferred with the parameter sets.

1. Obtain the OEM or service level passwords for B1 and B2.
2. On B1, download all of the current parameters from the LMV3 to the AZL flash memory via parameter 050. Select "Backup" and set the parameter to 1. This will begin the parameter download. This process is complete when the value changes back to 0. If the value changes to any number other than 0, a fault occurred during the parameter download.
3. Write down B1 burner ID. This can be found via parameter 113.

After this step, B1 LMV3 can be powered off. After B1 is powered off, remove the AZL.

4. If the burner ID on B2 is not the same as B1, change the burner ID on B2 to match B1 via parameter 113. The OEM or service level password will be required to change the burner ID.
5. Power off B2 LMV3. After B2 LMV3 is powered off, remove the AZL from B2 and replace with the AZL from B1. Power B2 LMV3 back on.
6. Now that the burner IDs match, the B1 parameter set can be downloaded into B2 via parameter 050. Select "Restore" and set the parameter to 1. This will upload all of the parameters from B1 AZL into the LMV3 on B2. This process is complete when the value changes back to 0. If the value changes to any number other than 0, a fault occurred during the parameter upload.
7. After this is complete, B2 can be powered down. The AZL from B1 can be returned to B1 and the AZL from B2 can be reconnected to B2. Power B2 LMV3 back on.
8. Change the burner ID on B2 to a unique value different than B1. Typically, the burner serial number is used.

NOTE: An exact copy of all parameters is transferred when the above procedure is executed, including light-off positions and Fuel-to-Air Ratio Control Curves. Typically, even "identical" burners and boilers need unique light-off positions and Fuel-to-Air Ratio Control Curves. Since this is typically the case, curves and ignition positions are typically deleted or modified after the parameter set is downloaded into a new burner.

Suggested Initial Light-off for LMV3 Systems

1. The following procedure assumes the following:
 - a. Fuel train 3 (Gp2 mod) was selected for a gas pilot burner.
 - b. Pre-requisites for Basic LMV3 systems (from above) are met.
 - c. Procedure for Configuring (Parameterization of) an LMV3 has been done (from above).
 - d. This is a first-time commissioning of the LMV3 and the combustion control curve is blank (no points are entered).
2. Close the manual main fuel (gas) valve that is downstream of the low gas pressure switch and pilot take-off.
3. Ensure the burner switch is off. If the LMV3 is not yet powered, turn on the power to the LMV3.
4. At this point, all safety interlocks that can be checked should be checked in a safe manner. This includes, but is not limited to: low water cut-offs, high temperature switches, high gas pressure switch, low gas pressure switch, proof of closure (POC) switch, etc.
5. Later in the procedure when the burner is running, the rest of the safety interlocks must be checked in a safe manner. This includes, but is not limited to: Air pressure switches, high steam pressure limits, draft switches, etc.
6. Hold down the F and A buttons together to access the LMV3 parameters. If not already logged in, log in using the OEM password. The default OEM password is "Entry". When parameter 400 is displayed, press Enter.
7. Parameter 201 will be displayed. Parameter 201 sets the fuel train type. This was set in an earlier step. If no changes are necessary, press the + button.
8. Parameter 542 will be displayed. Parameter 542 activates or deactivates the use of a VSD. This was set in an earlier step. If no changes are necessary, press the + button.
9. Parameter 641 will be displayed. Parameter 641 is used to standardize the VSD (if used). This was performed in an earlier step. If no changes are necessary, press the + button.
10. P0 will be displayed. P0 is the ignition position of the actuators and VSD. Hold down the F button and use the + and - buttons to set the ignition position for the fuel actuator. Hold down the A button and use the + and - buttons to set the ignition position for the air actuator. Hold down both the F and A buttons together and use the + and - buttons to set the ignition speed for the VSD. Once the safe ignition positions have been entered, press the + button.
11. P9 will be displayed. P9 is the high fire position of the actuators and VSD. Enter the same values that were used for ignition position P0. Once the safe high fire positions have been entered, press the + button.

12. The word “run” will be displayed. If the burner is ready to be turned on, press Enter.
13. The LMV3 will now be in Phase 12 and the burner is ready to be turned on. Turn on the burner switch. The burner should drive to pre-purge (Phase 24) and then drive to ignition (Phase 36). P0 will be displayed again. If no changes are desired for the ignition position, press the + button to attempt to light the pilot.
14. The pilot should light and the LMV3 should move to pilot stabilization (Phase 44). If the pilot does not light on a new installation, there could be air in the gas line. Bleed the air in a safe manner if necessary and attempt to re-light the pilot.
15. P0 will be displayed again once the pilot is lit. Tune the pilot by adjusting the ignition position of the air actuator and / or adjusting the pilot gas pressure regulator, if necessary. Pilot flame should be stable and return a flame signal of 85% or greater. To view the flame signal, hold down the Enter button.
16. Once a satisfactory pilot flame is established, press the + button. The burner should open the main fuel (gas) valves and attempt to light the main flame. The LMV3 should show a flame failure since the manual main fuel (gas) valve is closed.
17. If a flame failure does occur, turn off the burner switch and proceed to reset the LMV3. The text “OFF UPr...” should be displayed. Open the manual main fuel (gas) valve. To start the burner again, use the procedure from steps 6, 12, 13, 14, and 15 above to light the pilot off again. Once the pilot flame is established again and P0 is displayed, press the + button and attempt to light the main flame.
18. If the main flame lights, P0 will be displayed one last time. Adjust the ignition position of the gas valve to achieve a safe main flame. At this time, a calibrated stack gas analyzer should be inserted into the stack and used to evaluate combustion. If the main flame fails to light, the ignition position of the firing rate control valve and / or the gas pressure regulator may need to be adjusted to achieve a combustible mixture at the ignition position. After the combustion has been verified to be safe with an analyzer, parameter 208 can be set to 4 to hold the boiler at ignition position for a boil out or boiler warming if required.

Suggested Ratio Control Curve Commissioning

1. The procedure below assumes the following:
 - a. Pre-requisites for Basic LMV3 systems (from above) are met.
 - b. Procedure for Configuring (Parameterization of) an LMV3 has been done (from above).
 - c. This is a first-time commissioning of the LMV3 and the combustion control curve is blank (no points entered).
 - d. The burner has been lit off, and is at ignition position.
 - e. A calibrated stack gas analyzer is sampling the stack gas and can read %O₂ and ppm CO.
 - f. The boiler has been warmed up to operating temperature / pressure.

-
2. A free excel spreadsheet is available to assist in creating smooth fuel-to-air ratio curves and to record commissioning data for reference. This spreadsheet, called the LMVx Curves spreadsheet, can be found at www.scccombustion.com. The spreadsheet uses fuel flow to accurately lay out the fuel-to-air ratio curves. If fuel flow is not available, burner head pressure can be used as a last resort.

The next page shows how the LMVx Curves spreadsheet can be used to set up a steam boiler with a fuel actuator, air actuator, and a VSD. This is an example to illustrate what a typical setup might look like, and is not intended to be copied verbatim to an LMV3 in the field.

3. Press the + button to go to Point 1 (P1). Point 1 is automatically set to ignition position values.

NOTE: The text “P1” will be solid when the actuators / VSD are moving to the displayed position. The text “P1” will begin flashing when the indicated positions are reached.

4. If the low fire point is not known (maximum burner turndown), adjust the Point 1 actuator / VSD positions until maximum safe burner turndown is achieved. Once the desired low fire actuator / VSD positions have been achieved, record the Point 1 actuator / VSD positions and burner turndown in the LMVx Curves spreadsheet.

NOTE: While commissioning the Ratio Control Curves, it is the responsibility of the technician to ensure that safe fuel-to-air ratios are being maintained. If an AZL23 + or - button is held down when adjusting an actuator position, the position will be changed at a progressively faster rate.

5. Press the + button eight times until P9 (high fire) is displayed. Now increase the effective firing rate of the burner by increasing the actuator / VSD positions in a way that maintains a safe fuel-to-air ratio. This is typically accomplished by increasing air, fuel, and VSD positions in a stepwise rotation. Keep increasing the firing rate in this manner until high fire positions of the actuators / VSD are reached.

NOTE: Typically, the gas pressure regulator immediately upstream of the firing rate control valve will need to be adjusted on a new installation. Adjust the regulator such that the firing rate control valve is between 60-80° open at high fire.

6. Once high fire actuator / VSD positions and gas pressure regulator(s) are set, record the Point 9 actuator / VSD positions, burner head pressure at high fire, and burner output at high fire in the LMVx Curves spreadsheet.

Now that P1 (low fire) and P9 (high fire) have been set, and all of the appropriate information has been entered into the LMVx Curves spreadsheet, the fuel flow (or burner head pressure) at the remaining points on the fuel-to-air ratio curves are displayed in the spreadsheet.

NOTE: Exactly nine curve points (P1-P9), plus ignition position P0, are required to be entered.

	Indicates information to be filled out before commissioning ratio control curves
	Indicates information to be filled out during commissioning of ratio control curves

LMV3 Basic Burner - Gas		Units	Input Data
Application Info	Burner Output at High Fire	MM BTU / HR	8
	Burner Head (manifold) Pressure at High Fire	IN WC	6
	Burner Turndown	xx to 1	5
	Heating Value of Gas	BTU / SCFH	1000
	Boiler Efficiency	%	82

Actuator / VSD Ratio Control Curves										
		These Cells are Calculated from the "Application Info" Cells Above					Manually Input during Ratio Control Curve Commissioning			
CURVE POINTS	LMV Curve Point	Gas Flow to Burner (Auto Calc)	Burner Output		Burner Head Pressure (Approx)	Boiler Output @ Efficiency	Steam Flow 230° F Feed 100 PSIG Steam (Approx)	Air Actuator Position	Fuel Actuator Position	VSD Speed
	#	SCFH	MM BTU /HR	MW	IN WC	BHP	lb/hr	Deg	Deg	%
	1	1600	1.60	0.47	0.2	39.2	1324.3	5.0	3.0	55.0
	2	2400	2.40	0.70	0.5	58.8	1986.5	12.0	6.0	60.0
	3	3200	3.20	0.94	1.0	78.4	2648.6	22.0	12.0	65.0
	4	4000	4.00	1.17	1.5	98.0	3310.8	30.0	18.0	70.0
	5	4800	4.80	1.41	2.2	117.6	3972.9	42.0	28.0	75.0
	6	5600	5.60	1.64	2.9	137.2	4635.1	55.0	39.0	80.0
	7	6400	6.40	1.87	3.8	156.8	5297.3	63.0	48.0	85.0
	8	7200	7.20	2.11	4.9	176.4	5959.4	68.0	56.0	90.0
	9	8000	8.00	2.34	6.0	196.0	6621.6	75.0	64.0	95.0

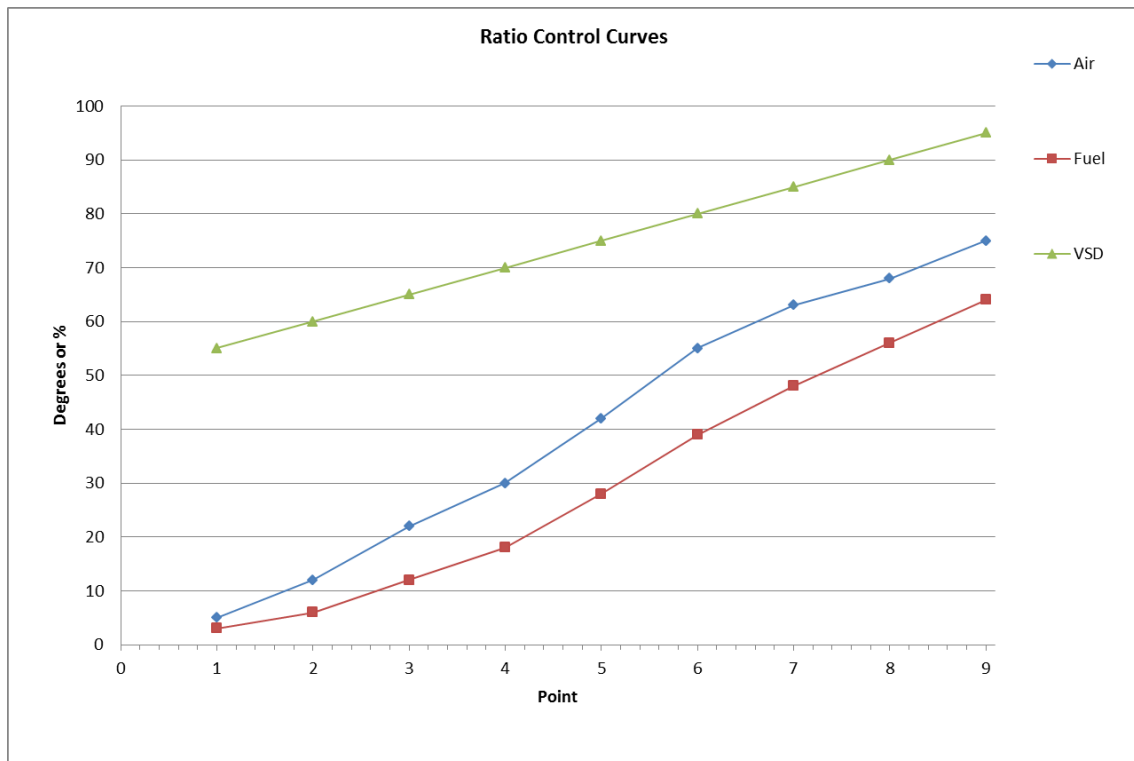

Figure 4-5: Example of LMVx Curves Spreadsheet

-
7. Still at P9 (high fire), hold the - button down until "CALC" is displayed.

NOTE: The CALC feature draws a linear curve between the point just set and either P1 (low fire) or P9 (high fire). Holding the + button after setting any curve point will linearize the curve from that point up to P9 (high fire). Holding the - button after setting any curve point will linearize the curve from that point down to P1 (low fire).

At this point, a linear curve is entered between Point 1 (low fire) and Point 9 (high fire). Moving now from Point 8 down to Point 1, continue to set each point at the calculated fuel flow (or burner head pressure). After each point has been set to achieve safe, efficient combustion and emissions compliance, hold the - key to perform the CALC function again and move to the next point. After Point 1 has been set, press the Escape button.

8. Parameter 546 will be displayed. Parameter 546 sets the maximum fire rate of the burner. Once this has been set, press the + button.
9. Parameter 545 will be displayed. Parameter 545 sets the minimum fire rate of the burner. Once this has been set, press the Escape button.

NOTE: Parameter 545 can only be set as low as 20%. This does not mean that the turndown of the burner is limited to 5:1. The LMV3 always denotes low fire as 20% load, even though the actuator / VSD positions set at Point 1 can achieve a much lower fire rate.

10. Parameter 400 appears. Press Escape. If the curve was set up correctly, the display should now show "oP" followed by the fire rate of the burner.
11. The following is a summary of what should be achieved for each point on the Ratio Control Curve:
 - a. Safe, efficient combustion as verified by a calibrated stack gas analyzer
 - b. Emissions compliance
 - c. Smooth Ratio Control Curves (no sharp peaks and valleys)
 - d. VSD speed should increase with load in a linear fashion (if equipped)

Additional Tips for Commissioning

- Using a fuel flow meter (temporary or permanent) for commissioning is always a good idea. If the fuel input (heat output) increases linearly with firing rate, the PID loop in any load control will be much more effective. A temporary, insertion type flow meter is available from SCC Inc. for this purpose.
- If burner head pressure must be used as a last resort to estimate firing rate, bear in mind that head pressure does not increase with gas flow in a linear manner. There is a square root relationship between the differential pressure across the burner head and the gas flow. This relationship is very similar to how the pressure varies across a fixed orifice with an increase or decrease in flow. Also, furnace pressure must be accounted for by hooking up both sides of the manometer, one side to the burner head pressure and one side to the furnace pressure.
- Carbon monoxide (CO) is produced when combustion is incomplete, typically due to the flame being too rich or too lean. CO is potentially explosive when mixed with air in the right proportions. For CO to be explosive in air, it must reach a concentration of at least 12.5% (125,000 ppm) with an ignition source present.
- If a burner is commissioned properly, actuator curves should increase smoothly with increasing load (firing rate). Curves should always be smooth, with no sharp corners.
- The best and fastest method to commission a burner with an LMV3 is to set up a small table where the technician can have his laptop, AZL, fuel flow meter, and external flue gas analyzer all within arm's reach. This allows the curve points to be input rapidly and accurately. If the information is entered in the laptop point by point, a very nice startup report will also be generated.
- The ACS410 software is not as fast as using the AZL to commission the LMV3. Since this is the case, the ACS410 is typically not used to commission the LMV3. However, the ACS410 is very valuable when used to download a startup report (all parameter settings, fault and lockout history, in English) and also when used to download parameter backups (the machine-language parameter set from the LMV3). It is recommended to download both of these files after commissioning, so that there is a backup record of all parameter and curve settings.
- Pressing the Enter button and any other button on the AZL at the same time will cause the LMV3 to immediately close the fuel valves and lockout.

Intentionally Left Blank

Section 1	Overview
Section 2	Wiring
Section 3	Parameters
Section 4	Commissioning
Section 5	VSD
Section 6	Troubleshooting
Section 7	Modbus
Section 8	ACS410
Appendix A	Application Guide

Section 1	Overview
Section 2	Wiring
Section 3	Parameters
Section 4	Commissioning
Section 5	VSD
Section 6	Troubleshooting
Section 7	Modbus
Section 8	ACS410
Appendix A	Application Guide

Section 5: Variable Speed Drive Control

Table of Contents

Introduction	2
VFD and AC Induction Motor Fundamentals.....	2
Line Reactors.....	3
Output Wiring / Load Reactors.....	4
Shaft Current.....	5
Braking Resistors.....	5
Types of VFDs: Vector and Volt/Hz	7
Configuring VFDs for use with the LMV3	7
Brushless DC Blowers (PWM Blowers).....	9
Centrifugal Blower Fundamentals	10
Standardized Speed - Standardizing the LMV3	11
Blower Speed Monitoring	16
Blower Speed Response during Operation	18
Suggested Setup Procedure for the VSD Control - Parallel Positioning Application	20
Suggested Setup Procedure for the VSD Speed Shift	23
Additional Tips for Burners with VSD Speed Shift	27
Additional Tips for Burners with VSD Control	28

Introduction

The LMV3 features an integrated, closed-loop Variable Speed Drive (VSD) control that is typically used to ramp the speed of the combustion air blower with firing rate. This is accomplished by transmitting a 0-10 VDC or a PWM (pulse-width modulation) signal from the LMV3 to the VSD, and then reading back the speed of the blower motor. The blower motor speed feedback can be accomplished two different ways. For three phase AC motors, a motor shaft mounted, safety-rated asymmetrical encoder wheel (speed wheel) and speed sensor is typically used. For DC brushless motors (PWM blowers), the speed signal is taken from Hall Effect sensors that commutate the brushless DC blower motor. On three phase motors where the direction of rotation can be easily changed, the LMV3 also monitors the direction of rotation with the asymmetrical encoder wheel, ensuring safe VSD operation.

Blower speed and direction of rotation have a large impact on the airflow delivered to the burner, and thus the fuel-air ratio. The most common type of VSD, a Variable Frequency Drive (VFD), is typically not safety-rated and will typically not fail in a safe manner (a VFD failure will typically cause the combustion air blower to slow down or stop, causing the burner to go rich). The combustion air pressure switch offers only a small amount of protection in a VFD application, since the switch must be set to allow low fire operation when the blower is spinning slowly and the blower output pressure is low. Blower speed feedback ensures that a blower failure will be quickly detected and the burner will shut down safely.

VFD and AC Induction Motor Fundamentals

VFDs are typically connected to a three-phase alternating current (AC) induction motor that is used to power the combustion air blower. Modern VFDs operate by taking single or three-phase AC and rectifying this power to high voltage direct current (DC) for the DC bus. The AC power is typically rectified to DC with banks of diodes. The DC bus feeds a bank of Insulated Gate Bipolar Transistors (IGBTs), and a microprocessor is used to fire the IGBTs in a way that the voltage and frequency of the modified sine waves can be controlled. This is done for each of the three phases on the VFD output. The microprocessor varies the voltage and frequency of the modified sine waves in response to a signal; in this case, the 0-10 VDC input.

By design, a three-phase AC induction motor will attempt to approximately synchronize its speed with the frequency of three-phase power that it is being fed. Thus, if the frequency can be adjusted, so can the speed of the motor. As their name suggests, three-phase induction motors generate magnetic fields in the rotor of the motor by using induction rather than by using slip rings or brushes. The advantage of this type of construction is very low maintenance, and a small disadvantage is a phenomenon called slip. Slip is defined as the difference between the theoretical speed at a given AC frequency and the actual speed at a given AC frequency. Slip increases as the load on the motor (torque output) increases.

Three-phase AC motors that do not have slip are referred to as synchronous motors, since these motors exactly synchronize their speed to the frequency of the incoming AC power. This type of motor is not typically used on blowers, but is mentioned as a comparison to the AC induction motor. A truly synchronous 2-pole motor will spin at exactly 3600 RPM if it is fed exactly 60 Hz. A truly synchronous 4-pole motor will spin at exactly 1800 RPM if it is fed exactly 60 Hz. In contrast, a 2-pole, three-phase AC induction motor fed 60 Hz will spin less than 3600 RPM, and how much less is determined by how heavily the motor is loaded and how much slip that loading causes.

As mentioned above, VFDs switch multiple IGBTs on and off very rapidly to generate a "modified" sine wave on all three phases going to the motor. Doing this has some tradeoffs, one of which is electrical noise, or harmonics. This noise is typically "wire borne" instead of airborne, and can cause issues with electronics in some situations. Thankfully, electrical noise associated with VFDs can be mitigated using proper wiring techniques (connecting shields and grounds correctly) and by the proper application of line reactors and / or load reactors for some applications. For difficult applications, EMC filters for the VFD are also available.

Line Reactors

Line reactors, or "chokes", are typically used when the impedance on the input side of the drive is low. Impedance on the input side of the drive is typically low when a relatively small VFD is being fed by a relatively large transformer. In this situation, the supply side of the drive is "stiff", meaning that an instantaneous current draw by the drive will be met very quickly by the large transformer (think square wave form), causing voltage and current distortions in the power distribution system feeding the drive. In this situation, adding a line reactor will add reactance which opposes instantaneous current draw and "softens" the input side of the drive.

Conversely, if the transformer feeding the drive is not large relative to the drive, the impedance on the input side of the drive is higher and the system is "softer". In this situation, an instantaneous current draw by the drive will not be met as quickly, and the resulting voltage and current distortions in the power distribution system feeding the drive will be smaller. An additional line reactor in this situation is not needed.

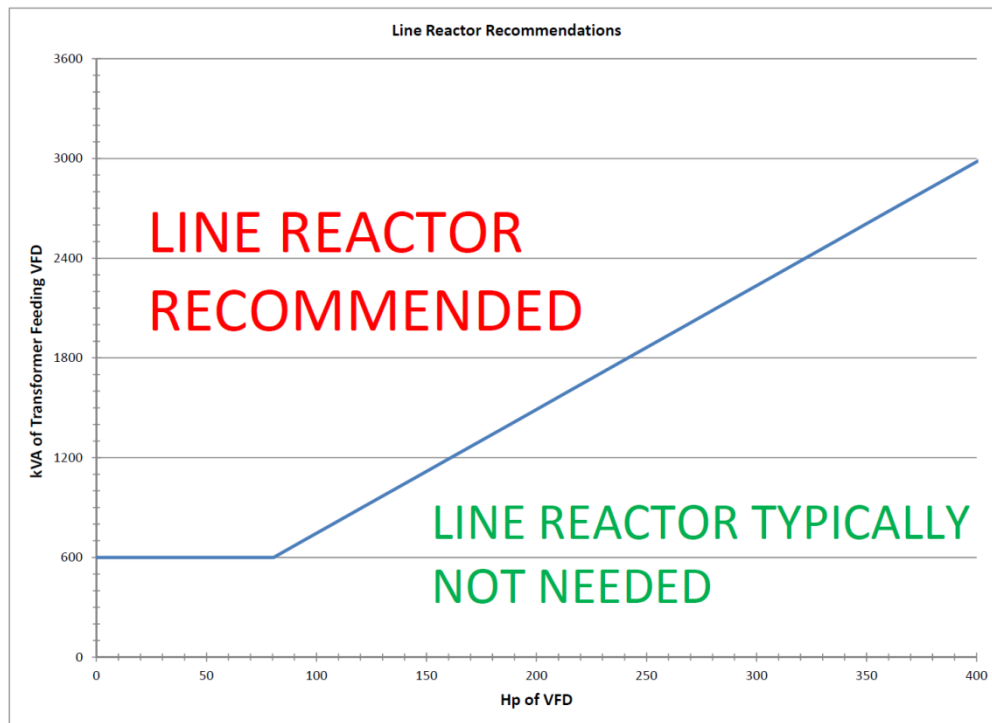

Figure 5-1: Line Reactor Recommendation - VFD (HP) vs Transformer (kVA)

In general, a line reactor is recommended if the supply capacity (kVA) of the transformer feeding the drive is greater than or equal to 10 times the capacity (kVA) of the drive for transformers 600 kVA and larger.

Figure 5-1 notes:

1. Drive power is shown in HP rather than kVA. This conversion can be done assuming a power factor of unity (1) and negligible losses due to efficiency.
2. Transformers less than 600 kVA have high enough impedance (are “soft” enough) so that line reactors are typically not necessary.

Example 1: A 25 HP drive is being fed by an 800 kVA transformer. Is a line reactor required?

Assumptions:

The power factor is unity (power factor = 1)

Losses due to efficiency and wiring are negligible

1. Convert horsepower to kilowatts: $25 \text{ HP} \times 0.745 \text{ HP/kW} = 18.63 \text{ kW}$
2. Convert kilowatts to kVA: $\text{kW} = \text{kVA} \times \text{Pf}$ (Pf is power factor, which is assumed to be 1 in this example)
Thus, a 25 HP drive is 18.63 kVA.
3. Calculate the kVA ratio: $800 \text{ kVA} / 18.63 \text{ kVA} = 42.94$
Since a ratio of 42.94 is greater than 10, and the transformer is larger than 600 kVA, a line reactor will be necessary for this application. The same conclusion can also be arrived at by using Figure 5-1.

Example 2: A 10 HP drive is fed by a 400 kVA transformer. Is a line reactor required?

Using the same assumptions and calculation as example 1, the kVA ratio is 53.7, but the transformer is smaller than 600 kVA, so a line reactor is not necessary. The same conclusion can also be arrived at by using Figure 5-1.

Output Wiring / Load Reactors

When the VFD / motor are running, high levels of electrical noise are produced on the wiring between the VFD and the motor. This is due to the fact that modified sine waves produced by the drive IGBTs are basically high frequency / high voltage DC pulses. These output wires must be enclosed in some type of shielding (metallic conduit or metal-shielded cable) to mitigate radiated electrical noise.

Wire length between the VFD and the motor should be kept to less than 150 feet if possible due to the reflected wave / standing wave phenomenon and voltage overshoot phenomenon. Both of these phenomena are rather complex, and are a function of the wire length from the VFD to the motor. The reflected wave / standing wave phenomenon and voltage overshoot phenomenon can damage non-inverter duty motor windings over time due to the high peak voltages that these phenomena can produce.

NOTE: The DC bus runs at voltages substantially higher than the incoming voltage to the drive (about 35% higher) and typically employs large capacitors. These capacitors remain charged for a period of time after the incoming power to the drive is de-energized, and are a shock hazard until they discharge. See the VFD manufacturer's recommendations for minimum waiting time to work on the drive after the drive is de-energized.

If wire length cannot be kept to less than 150 feet on the drive output, correction options are available. These are listed in Figure 5-2:

Wire Length - up to (ft)	Correction Option
150	None Required
300	Load Reactor at VFD Output
650	Load Reactor at Motor Input
2000	dV/dT Filter on VFD Output
Consult Motor OEM	Inverter Duty Motor

Figure 5-2: Correction Options for Long Wire Length between VFD and Motor

Shaft Current

As was mentioned earlier, the fast switching or "firing" of the IGBTs enable the VFD to produce modified sine waves of different frequencies and different voltages in order to speed up or slow down a motor. The fast switching of the IGBTs does have electrical side effects, some of which are detailed on the previous pages.

This fast switching of the IGBTs can also cause "shaft current" on the motor. When this happens, a voltage charge builds up on the motor's shaft. When this voltage gets high enough, it will arc to ground through the path of least resistance. The path of least resistance is typically the ball bearings that support the rotor of the motor. When this arcing occurs in the bearings, damage occurs to the bearings. Over time, the bearings will be destroyed, and the motor will fail.

Shaft current can be mitigated by using a grounding ring, which is typically bolted to the motor housing and has some type of conductive filament that contacts the shaft, thus grounding the shaft. Some motor OEMs have grounding rings built into the motor, so an external ring is not necessary.

Braking Resistors

Three-phase AC induction motors can also function as three-phase AC generators if they become driven by what they typically drive. In the case of a blower, the motor drives the blower wheel when the speed of the wheel is increased (accelerated). Conversely, the blower wheel can drive the motor when the speed of the blower wheel is decreased (decelerated) with a closed air damper. When the motor is driven by the blower wheel, it will act as a generator and "push" electrical energy back to the VFD. This energy will be seen as a voltage increase on the VFD's DC bus.

The DC bus can absorb a small amount of energy in the DC bus capacitors. However, if the motor generates more than what these capacitors can absorb, the DC bus voltage will rise to critical levels and one of two actions will be taken by the VFD. Depending on the parameter settings of the VFD, the VFD will either stop decelerating (stall prevention) or the VFD will alarm and shut down. Either one of the actions is not a desirable result on a combustion air application.

To avoid DC bus overvoltage issues, a braking resistor can be added to the VFD so that the excess electrical energy generated by decelerating the blower wheel can be turned to heat. This process happens seamlessly so that the VFD can decelerate the blower smoothly.

Due to a number of variables, it is difficult to determine if a braking resistor will be needed on a particular application unless that application has been tested. The only disadvantage of having a braking resistor and not needing it is cost and possibly the space for the resistor. Burners having the following characteristics will typically need a braking resistor:

1. A heavy, high inertia blower wheel - Kinetic energy is stored in a spinning wheel. The heavier the blower wheel, the greater the stored energy. When this wheel is slowed down, the kinetic energy must go somewhere, and it is usually "pushed" back to the VFD as electrical energy.
2. Fast ramp times - The faster the ramp times, the faster the blower wheel must be accelerated and decelerated. Just like a car, more energy is required to accelerate quickly (bigger engine) and more energy is required to be dissipated when decelerating quickly (bigger brakes). Decelerating a given blower wheel more quickly will push more electrical energy back to the VFD.
3. Mostly closed air damper - A motor spinning at 3600 RPM draws fewer amps with a closed or nearly closed air damper as compared to a wide open air damper. Thus, the horsepower used by the motor and the drag (braking) on the blower wheel will be much less with a closed or nearly closed air damper. Decelerating a given blower wheel with reduced drag will also push more electrical energy back to the VFD.

As one might expect, the above points compound one another. Decelerating a heavy blower wheel with a fast ramp time and a mostly closed air damper will push a large amount of electrical energy back to the VFD and will likely cause DC bus overvoltage issues if a braking resistor is not installed.

In contrast, a light blower wheel (sheet metal instead of cast iron), a slower ramp time (90 seconds instead of 30 seconds), and slowing the blower down on a more open air damper are characteristics that will greatly reduce the amount of electrical energy pushed back to the VFD and should allow the braking resistor to be omitted in most cases.

On some models of VFDs, braking resistors can be added after the VFD is installed if necessary. This is a point to consider when installing VFDs for combustion air applications.

Types of VFDs: Vector and Volt/Hz

Although there are over a hundred different manufacturers of VFDs, two main types of VFDs are produced by these manufacturers for use on blower motors. These two types are Vector and Volt/Hz. Vector VFDs can usually be run in either Vector mode or Volt/Hz mode. Vector VFDs are also typically slightly more expensive than Volt/Hz VFDs for a given size.

The advantage of Vector VFDs is that they provide more accurate torque control of the motor. This accurate torque control enables much more accurate speed control of the motor, especially at lower motor speeds. More accurate speed control of the motor enables more accurate, repeatable control of the airflow.

As mentioned earlier, the LMV3 employs a safety-related speed feedback on the blower shaft, thus continuously checking and adjusting (if necessary) the signal to the VFD to achieve the desired blower speed within a certain band. The LMV3 can lockout and shut down the burner if blower speed deviations are large and persist for too long. Due to their increased accuracy, Vector VFDs provide trouble-free operation on almost all LMV3 VFD blower applications. Volt/Hz VFDs can work satisfactorily in some applications, but are not preferred due to their decreased accuracy.

Vector VFDs are typically run in Open Loop Vector (OLV) mode. In this mode, the VFD uses a mathematical model of the motor combined with extremely accurate, fast scanning of the current and other data taken from the rotating motor. In reality, Open Loop Vector mode does have feedback, but the Vector VFD itself does not require a separate encoder to achieve this.

Since Vector VFDs use a mathematic model of the motor, and the design of motors differs somewhat between motor OEMs, a static or dynamic auto-tune is sometimes required so that the Vector VFD "learns" key aspects of the motor it is connected to. A static auto-tune (motor is not spun) does not require that the load (blower wheel) be de-coupled from the motor. A dynamic auto-tune (motor is spun) typically requires that the load (blower wheel) be de-coupled from the motor, which is not possible or practical in many situations. A dynamic auto-tune typically generates the best "learning" of the motor properties. A static auto-tune is typically all that is necessary if speed control issues are encountered on a vector VFD.

Configuring VFDs for use with the LMV3

Modern VFDs typically have hundreds of parameters that can be set to tailor the VFD to a specific application. As mentioned earlier, there are also at least a hundred different manufacturers of VFDs, each of which have their own unique parameter list. Due to these two factors, SCC offers pre-programmed VFDs that can be purchased with the VFD parameters set up for use with an LMV3.

If a VFD for use with an LMV3 is purchased and programmed independently, the following points will serve as a general guideline for programming the VFD for the LMV3 application. Note that these guidelines are necessarily general due to the variety of VFDs offered in the marketplace.

1. If a Vector VFD is used (recommended), set the "Control Method" to Open Loop Vector mode or equivalent.

-
2. The stopping method (after the run / stop contact is opened) should be set to "Coast to Stop" to let the motor coast to a stop after post-purge.
 3. Reverse operation (the ability to reverse the motor with an input) should be disabled.
 4. Configure the VFD to accept an external run / stop signal via a dry contact on the relay wired to the LMV3 blower motor starter output.
 5. The VFD should be able to do a "flying start" so that the VFD will not try to stop a free-wheeling blower wheel before starting the wheel spinning again. Blower wheels frequently free-wheel due to draft and other factors.
 6. Ramp times - the VFD should be set to slightly faster ramp times compared to the LMV3 ramp times (LMV3 parameters **522 Ramp Up VSD**, **523 Ramp Down VSD** and **544 ModulationRamp**). For example, if the LMV3 VSD ramp up time is set to 40 seconds, the ramp up time in the VFD should be set no longer than 35 seconds. The same is true with the ramp down time. A 5 second differential will work well in most situations.

Note: If short ramp times are necessary with large blowers (heavy blower wheels), a braking resistor may be necessary. See the braking resistor explanation on the previous pages.
 7. Ramps must be linear with the 0-10 VDC signal. S-shaped ramps and PID / filtering on the 0-10 VDC signal will cause speed faults on the LMV3.
 8. The VFD analog input signal should be configured for a 0-10 VDC signal and it should be spanned so that 0 VDC = 0Hz and 10 VDC = 62 Hz (for blowers designed for 60 Hz power). The additional 2 Hz is to make sure that full blower speed is achievable even with a 9.5 VDC standardization (see standardization section below).
 9. The motor nameplate data must be entered for the motor that the VFD is connected to.
 10. Some VFDs have a feature that will stop ramping the drive if a critical limit in the drive is approached. On some VFDs, this feature is referred to as "stall prevention". Two common limits are the maximum amperage drawn and the DC bus voltage. Stall prevention, while protecting the drive, can cause speed faults with the LMV3 due to the drive ceasing to ramp in concert with the LMV3. If a braking resistor is used, stall prevention can typically be deactivated.
 11. For Vector VFDs, perform at least a static auto-tune so that the VFD "learns" the characteristics of the motor it is connected to. A static auto-tune does not require that the load (blower wheel) be disconnected since the load is not spun. Some dynamic auto-tunes require that the load (blower wheel) is disconnected.
 12. If a braking resistor is being used, the braking resistor will typically have a high temperature switch. The drive should be programmed and wired so that a braking resistor over temperature will cause the drive to shut down.

Brushless DC Blowers (PWM Blowers)

Another common type of variable speed blower used with the LMV3 is the brushless DC blower, commonly referred to as a PWM blower. These blowers typically have the variable speed drive and DC brushless motor integrated into one blower mounted unit. These blowers are typically fed single phase or three phase AC voltage directly, and use some type of AC to DC rectification to produce the DC voltage pulses necessary to drive the blower motor.

Unlike a brushed DC motor, field windings in the brushless motor are triggered (commutated) via non-contact Hall Effect sensors. In addition to commutating the motor, these Hall Effect sensors also provide a pulse output (typically 2 or 3 pulses per revolution) that the LMV3 can use for blower speed feedback. For this reason, an external speed wheel with external speed sensor is not typically required for PWM blowers. Wiring of the speed feedback signal is covered in Section 2 - Wiring.

Brushless DC motors usually do not have the same speed limitations as most three phase blower motors do. While most three phase blower motors are limited to about 3800 RPM, some DC brushless motors used in blower applications will spin in excess of 10,000 RPM. This high-speed capability is attractive in a blower application since more air flow at higher pressures can be generated with a smaller blower. The LMV3 can read blower speeds up to 14,000 RPM via the Hall Effect sensors in the blower, and this is not a limitation in most applications.

Accurate speed control of a brushless DC motor can be more challenging as compared to a VFD and a three phase AC motor. The primary reasons behind this are the electromechanical characteristics of the motors themselves. As previously mentioned, the speed of a three phase AC motor will follow the frequency of sine waves (AC power) that is being fed with a small amount of variance due to torque induced slip. An increased torque (power) demand will cause a small amount of additional slip and will cause greater amperage draw. Variances in voltage, unless these are extreme, will not cause the motor to change speed. Thus frequency is the primary variable; voltage and torque are secondary variables. In brushless DC motors, the motor windings are being fed DC pulses of variable duration (hence these blowers being called pulse-width modulation - PWM). The width of these pulses determines the blower's speed for a given torque output and for a given blower input voltage. All three of these variables – pulse width, torque output, and input voltage have a substantial impact on the blower's speed and can be regarded as primary variables.

Some PWM blowers have internal speed controls that compensate for torque output and input voltage variances. This is done by taking a commanded speed set point (dictated by the LMV3) and adjusting the width of the pulse to achieve the commanded speed. PWM blowers having fast updating, properly tuned internal speed controls typically work well with the LMV3.

The ramp rates of a PWM blower carry many of the same considerations as a VFD with a three phase motor (see above). Increasing the blower speed (ramping up) is typically not an issue; however, ramp times may need to be increased when decreasing the blower speed (ramping down), especially if the blower wheel is heavy and / or the air damper is mostly closed.

Centrifugal Blower Fundamentals

Since a centrifugal blower is the piece of machinery being controlled by the LMV3, a brief mention of its basic characteristics is warranted. Specifically, there are three fundamental "fan laws" that a person working with such equipment should be aware of. These are:

1. Air flow varies linearly with the speed of the blower. In other words, the CFM of the blower is directly proportional to the RPM of the blower.

$$\text{CFM (new)} = \frac{\text{RPM (new)}}{\text{RPM (old)}} \times \text{CFM (old)}$$

2. The static output pressure of the blower (SP) varies by the square of the change in RPM:

$$\text{SP (new)} = \left(\frac{\text{RPM (new)}}{\text{RPM (old)}} \right)^2 \times \text{SP (old)}$$

3. The required brake horsepower of the blower (BHP) varies by the cube of the change in RPM:

$$\text{BHP (new)} = \left(\frac{\text{RPM (new)}}{\text{RPM (old)}} \right)^3 \times \text{BHP (old)}$$

Example: A blower spinning at 1750 RPM produces 10 in WC of static pressure, 4500 CFM of flow, and requires 20 BHP. What happens if the RPM is increased to 2750 RPM?

Assumptions: Air damper is wide open, and system effects (such as the restriction due to the boiler's heat exchanger, the burner's diffuser, etc...) are not taken into account.

Flow: CFM (new) = (2750 / 1750) * 4500 = 7071 CFM

Pressure: SP (new) = (2750 / 1750)² * 10 = 24.7 in WC

Power: BHP (new) = (2750 / 1750)³ * 20 = 78 BHP

Standardized Speed - Standardizing the LMV3

After the VSD blower is installed, wired and programmed correctly (see Section 2 for wiring), the LMV3 must be standardized.

The purpose of the standardization (calibration) procedure is to establish a relationship between the speed signal sent to the VSD (0-10 VDC or PWM) and the actual speed (RPM) of the blower wheel. This is done by correlating the speed signal to the actual RPM at two points: Near maximum speed and also when the blower is stopped.

The near maximum speed is read by sending either a 95% or 98% speed signal to the VSD, and then recording what speed was achieved. On the minimum speed side, 0% speed signal is assumed to be 0 RPM. The electronics in the LMV3 then “draw a line” between these two points (linear interpolation) to establish the expected speed response of the blower to a given speed signal. See Figure 5-4.

The standardization procedure is automated, and is activated by setting parameter 641 to a value of 1. When this is done, the following should occur:

1. The air damper is opened to pre-purge position.
2. The blower output (X3-05.1) is energized, closing a relay and enabling the VFD (if equipped).
3. A 95% or 98% speed signal is applied to the VSD. This can be a 0-10 VDC or a PWM signal. If parameter 661 is set to 0, then a 95% signal will be used. If parameter 661 is set to 1, a 98% signal will be used.
4. The blower ramps up to speed. After the speed has stabilized, the actual RPM is recorded by the LMV3 and is stored under parameter 642.
5. The speed signal is returned to 0%, and the blower is allowed to ramp down.
6. The blower output (X3-05.1) is de-energized.
7. The air damper returns to its home position.
8. If a value of 0 appears on the AZL after standardization, then the procedure was completed without error. If a value appears other than 0, see Error Code 82 in Section 6 of this manual.

NOTE: The LMV3 will not standardize if the safety loop is open, or if the burner switch is on. Ensure that the safety loop is closed and the burner switch is off before attempting to standardize.

A typical standardization process for a 2-pole (~3600 RPM) three phase blower with VFD is shown graphically in Figure 5-3. If a standardization was performed on a brushless DC blower (PWM blower) the procedure would be similar but the peak blower speed would be substantially higher (typically 5,500 RPM to 14,000 RPM) and the speed signal used for standardization would be 98% due to parameter 661 being set to a value of 1 for a PWM blower.

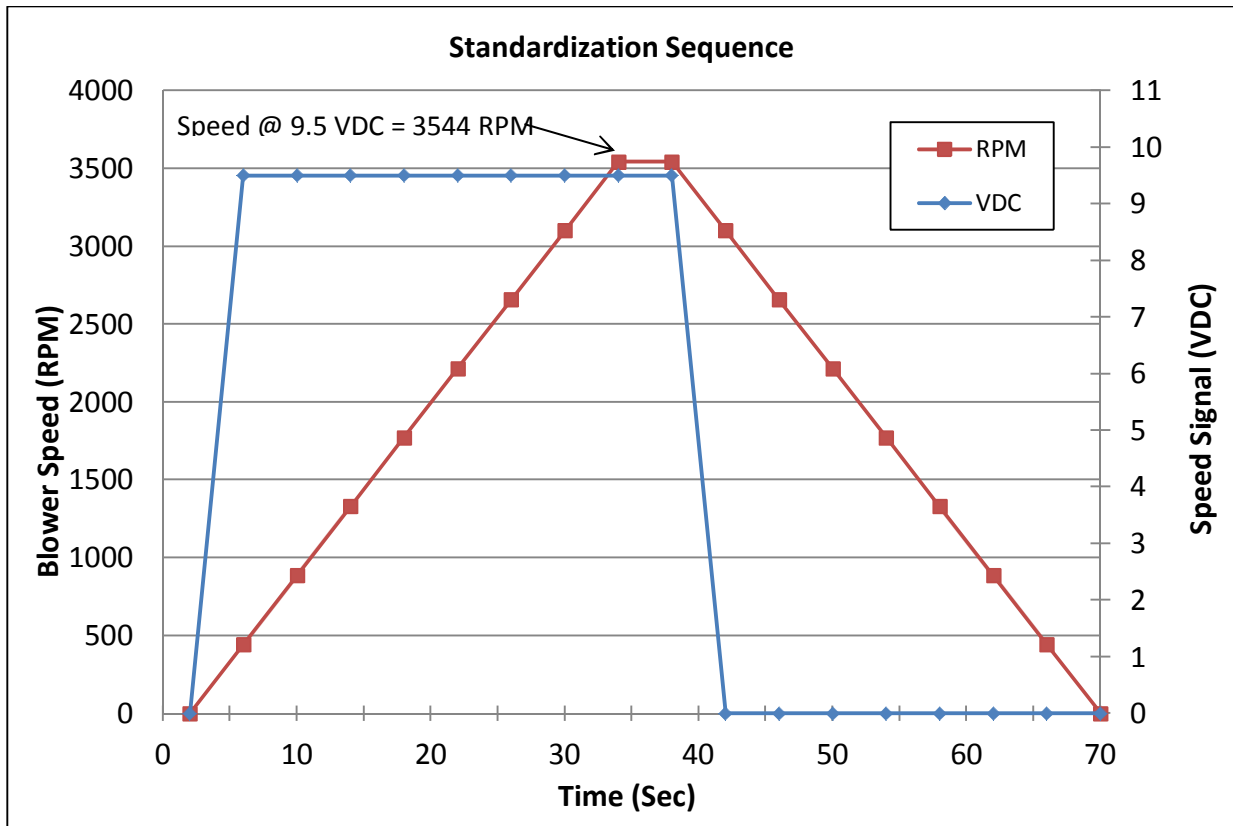

Time (sec)	LMV3 output to VSD (VDC)	Blower Wheel Speed (RPM)	VFD output Freq. (Hz)
2	0	0	0
6	9.5	443	7.5
10	9.5	886	15.0
14	9.5	1329	22.5
18	9.5	1772	30.0
22	9.5	2215	37.5
26	9.5	2658	45.0
30	9.5	3101	52.5
34	9.5	3544	60.0
38	9.5	3544	60.0
42	0	3101	52.5
46	0	2658	45.0
50	0	2215	37.5
54	0	1772	30.0
58	0	1329	22.5
62	0	886	15.0
66	0	443	7.5
70	0	0	0.0

Figure 5-3: Standardization Process for a 2-Pole Blower Motor (values are approximate)

NOTE: The total time of the standardization shown in Figure 5-3 is 70 seconds with a VFD ramp time of 30 seconds. Longer VFD / LMV3 ramp times will increase the total time taken for the standardization.

NOTE: The VFD in the example above is spanned so 10 VDC = 62 Hz. Thus, 9.5 VDC is approximately 60 Hz.

Based off of the RPM that was read at 9.5 VDC (in this case 3544 RPM) and an assumption of 0 RPM at minimum signal (0 VDC), a two point linear interpolation is automatically done by the LMV3, which establishes the linear relationship between the speed signal and the blower RPM.

In fact, this relationship is the slope of the line with a 0 intercept, and is defined with an equation. This equation states that for every 1 VDC increase in speed signal, the blower speed should increase by 373.05 RPM. This relationship is shown in Figure 5-4.

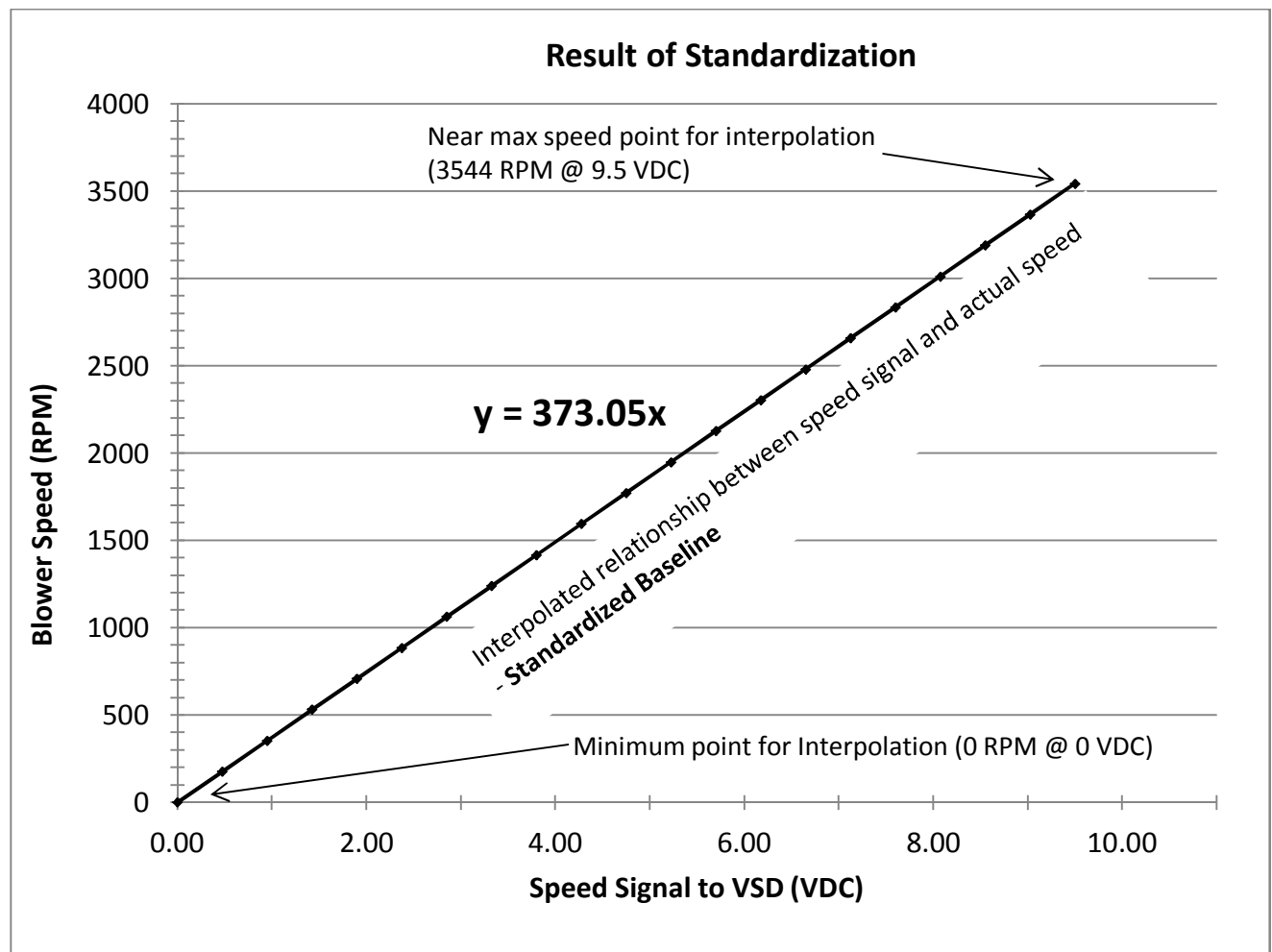

Figure 5-4: Result of Standardization (2-Pole Blower Motor) and Interpolation

Results of Standardization			Approximate Correction Limits	
LMV3 Speed Signal to VSD (%)	Blower Wheel Speed (RPM)	LMV3 Signal to VSD (VDC)	Maximum Signal to Correct for Low RPM (VDC)	Minimum Signal to Correct for High RPM (VDC)
0	0	0.00	VSD does not control below 10%	
5	187	0.50		
10	373	1.00	2.5	0.0
15	560	1.50	3.0	0.5
20	746	2.00	3.5	1.0
25	933	2.50	4.0	1.5
30	1119	3.00	4.5	2.0
35	1306	3.50	5.0	2.5
40	1492	4.00	5.5	3.0
45	1679	4.50	6.0	3.5
50	1865	5.00	6.5	4.0
55	2052	5.50	7.0	4.5
60	2238	6.00	7.5	5.0
65	2425	6.50	8.0	5.5
70	2611	7.00	8.5	6.0
75	2798	7.50	9.0	6.5
80	2984	8.00	9.5	7.0
85	3171	8.50	10.0	7.5
90	3357	9.00	10.5	8.0
95	3544	9.50	10.5	8.5

Figure 5-4 (continued): Result of Standardization (2-Pole Blower Motor) and Interpolation

When the burner is in operation, the LMV3 can be programmed to have active, closed-loop control of the blower motor speed and can compensate for motor slip and other factors within limits. The speed control signal can be increased to compensate for low blower RPM and decreased to compensate for high blower RPM. These speed control signal correction limits are also shown in Figure 5-4.

NOTE: The LMV3 will not attempt to correct the blower speed if the internal speed control is deactivated. This is determined by parameter 661 in the LMV3. If parameter 661 is set to 1, the LMV3 will attempt to correct blower speed back to the standardized baseline using its internal speed control. If parameter 661 is set to 0, the LMV3 will not attempt to correct blower speed back to the standardized baseline. In either case, the blower speed will still be monitored by the LMV3.

NOTE: Typically, parameter 661 is set to 1 (LMV3 speed control active) for VFD and is set to 0 (LMV3 speed control deactivated) for PWM Blowers. PWM blowers typically utilize a built in, high scan rate speed control that is tuned for that specific blower's characteristics. Typically, the speed control built into the PWM blowers is utilized instead of the LMV3 speed control for the reasons stated above.

If the speed control signal is increased to the maximum allowable signal and the blower RPM is still low, an Error Code 83, Diagnostic Code 2 will be displayed on the AZL.

If the speed control signal is decreased to the minimum allowable signal and the blower RPM is still high, an Error Code 83, Diagnostic Code 1 will be displayed on the AZL.

The reason that the standardization is done at 9.5 VDC instead of at 10 VDC is to give the LMV3 some additional "room" to increase the speed control signal for a low RPM condition at high fire. Because the standardization is done at 9.5 VDC, the analog input on the VFD is spanned so that 10 VDC = 62 Hz. This is done so that the blower will still achieve full 60 Hz blower speed at high fire on jobs where the blower is just large enough.

NOTE: Most VFDs can be scaled to output 400 Hz or more. Consult the blower and / or motor manufacturer before over-speeding the motor and blower, since blower wheels and motor rotors can catastrophically fail if RPM limits are exceeded.

In addition to limits on how much the speed control signal can be compensated, the LMV3 also has limits on how far the blower speed can deviate from the standardized speed baseline. These blower speed deviation limits are valid, independent of the activation or deactivation of the LMV3's internal speed control (parameter 661). The next section explains how the blower speed is monitored when the burner is in operation.

Blower Speed Monitoring

The LMV3 relies on its connected devices to achieve an accurate, repeatable fuel-to-air ratio from low fire to high fire. These connected devices are typically the SQM33 actuators and a VSD blower. The accuracy and repeatability of the burner's fuel-to-air ratio is directly dependent on how accurately the actuators can be positioned, and how accurately the blower's speed can be controlled. Different burners in different applications have different requirements for the accuracy of the fuel-to-air ratio. To accommodate these requirements, the LMV3 has adjustable tolerance bands for both the actuator's angular position and the VSD's blower speed.

To help ensure that the burner is either operated at a safe fuel-to-air ratio or is shut down, the blower speed is constantly monitored while a flame is present in the boiler. The speed is monitored in a way that nuisance shutdowns are eliminated, but fast shutdowns will occur if the speed deviation is large. To do this, the LMV3 evaluates the magnitude of the speed deviation in combination with how long the speed deviation exists. Three distinct tolerance bands and one limit centered about the standardized speed line are used. These bands are:

1. **Neutral Band** - if the speed is within this band, it is considered to be OK and no action is taken. The width of this band is adjustable via parameter 662 and the range is +/- 0.5 to 3.5% of the standardized speed. Burner modulation is temporarily paused if blower speed is out of the neutral band.
2. **Near Zone Band** - if the speed is within this band, the active speed control (in the LMV3 or VSD) will be working to bring the speed back into the Neutral Band. If the Neutral Band speed cannot be achieved in 8 to 16 seconds (adjustable by parameter 664) a lockout will occur. The width of this band is adjustable via parameter 663 and the range is +/- 2.0 to 5.5% of the standardized speed.
3. **Outside Near Zone** - if the speed is outside the Near Zone Band but does not exceed the High Risk Limit, the active speed control (in the LMV3 or VSD) will be working to bring the speed back into the Near Zone Band and then ultimately into the Neutral Band. The width of this band varies with the setting of the Near Zone band, parameter 663. If the Low Risk Band speed cannot be achieved in 3 to 7 seconds (adjustable by parameter 665) a lockout will occur.
4. **High Risk Limit** - if the speed exceeds the High Risk Limit threshold for more than 1 second, a lockout will occur. The timing and width of the High Risk limit is not adjustable. It is set to +/- 10% of the standardized speed.

These bands are shown graphically in Figure 5-5 below.

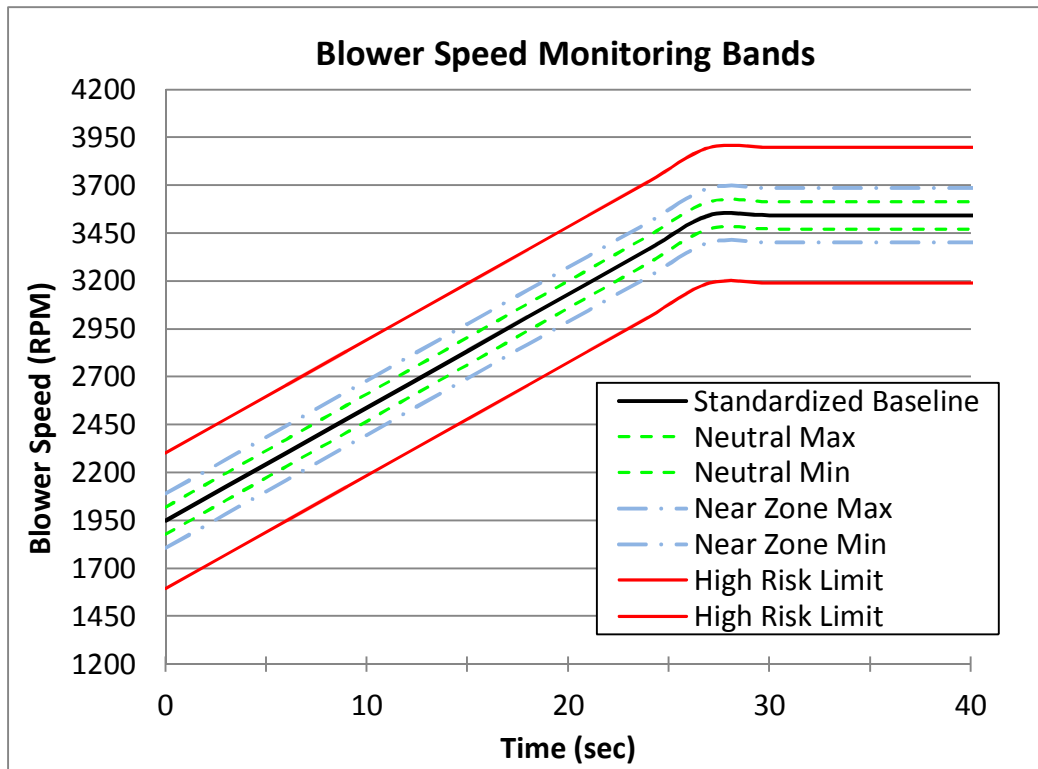

Name and Timing of Speed Band				Neutral Band No Time Limit		Near Zone Band 8 to 16 sec		Outside Near Zone 3 to 7 seconds		High Risk Limit 1 second
High Limit of Speed Band				+0.5% to 3.5%		+2.0% to 5.5%		Near to +10%		10% or greater
Low Limit of Speed Band				-0.5% to -3.5%		-2.0% to -5.5%		Near to -10%		-10% or less
Parameter to Adjust Width of Band				662		663		None		None
Parameter to Adjust Band Timing				None		664		665		None
RPM Tolerance for Standardized Speed of 3544 RPM Neutral Band = 2%, Near Zone = 4%				+/- 71		+/- 142		+/- 354		More than +/- 354
RAMP UP	Time	VSD	Standardized speed line	Max	Min	Max	Min	Max	Min	
	sec	%	RPM	RPM	RPM	RPM	RPM	RPM	RPM	
	0	55	1949	2020	1878	2091	1807	2303	1595	
	3	60	2126	2197	2055	2268	1984	2480	1772	
	6	65	2304	2375	2233	2446	2162	2658	1950	
	9	70	2481	2552	2410	2623	2339	2835	2127	
	12	75	2658	2729	2587	2800	2516	3012	2304	
	15	80	2835	2906	2764	2977	2693	3189	2481	
	18	85	3012	3083	2941	3154	2870	3366	2658	
	21	90	3190	3261	3119	3332	3048	3544	2836	
24	95	3367	3438	3296	3509	3225	3721	3013		
27	100	3544	3615	3473	3686	3402	3898	3190		

Figure 5-5: Blower Speed Monitoring Bands

Looking at the blower speed monitoring bands in Figure 5-5, and also the standardized speed baseline shown in Figure 5-4, it is clear that the LMV3 expects the VSD blower to have a linear response through the operating range. However, no VSD blower will have a perfectly linear response. The next section will illustrate how linear VSD blower response must be to have trouble-free operation.

Blower Speed Response during Operation

As was mentioned in the last section, the LMV3 expects the VSD blower to have a linear relationship between the speed signal and the actual speed. For a 9.5 VDC speed signal and a 3544 RPM standardized speed (as seen in the examples above) this relationship is precisely $y = 373.05x$ where x is the signal and y is the RPM. On real VSD blowers, it is not practical for the relationship to be perfectly linear, so the LMV3 has adjustable tolerance bands and adjustable timings for these bands to deal with some non-linearity between the speed signal and the actual speed.

Assuming that the VSD blower is programmed to have a linear response to the speed signal, the main source of non-linearity is ramping the blower speed up and down. The faster the ramp rates (shorter times) the more difficult it is for the VSD blower to keep a linear response. This is mostly due to the inertia of the rotating parts in the motor and blower. Slower ramp rates (longer times) will help minimize the inertia effects of the blower, especially when ramping down. Electronic breaking is very helpful when attempting to ramp down a high inertia motor and blower combination quickly.

Figure 5-6 below shows a typical VSD blower ramping up during operation (accelerating). The dashed lines represent the borders of the neutral zone, set by parameter 662. A setting of 2.5% is shown below, which will yield a neutral band of +/- 2.5% or 5% total. These percentages are of the standardized speed, so in absolute terms $2.5\% * 3544 = +/- 89 \text{ RPM}$ or 177 RPM total neutral band, at all VSD speeds from 10% to 100%.

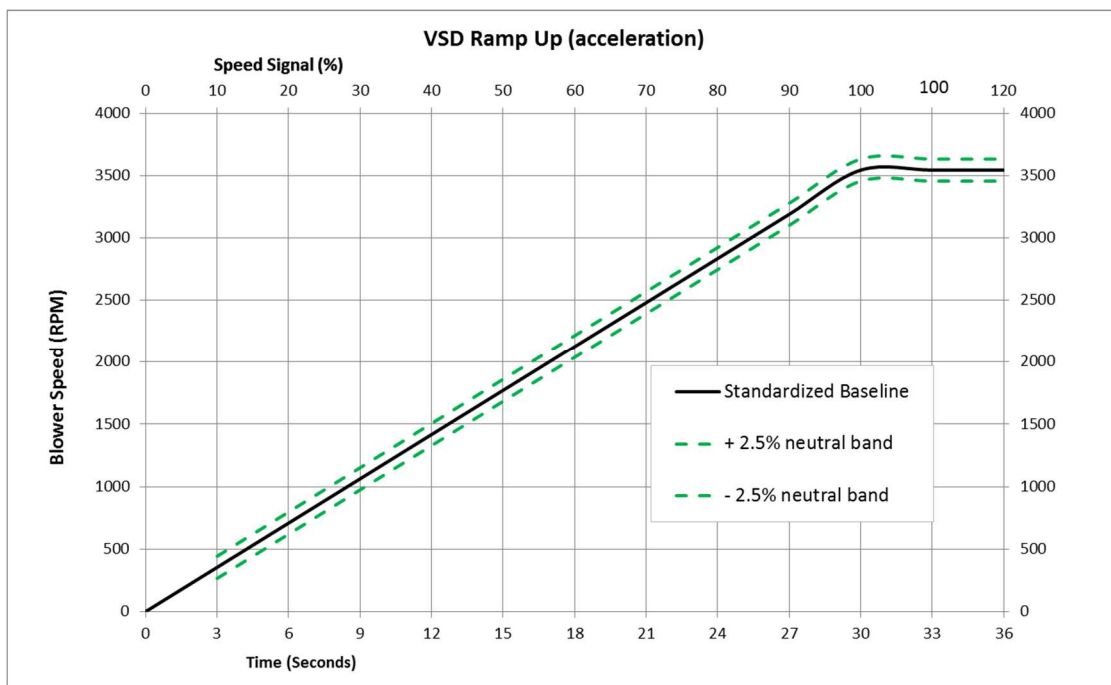

Figure 5-6: VSD Blower Speed Response during Acceleration

For the standardized speed and the setting of parameter 662 shown above, the blower can deviate from the standardized speed baseline by +/- 2.5% of the standardized speed (+/- 89 RPM) at anywhere from 10% to 100% VSD without causing the LMV3 to pause modulation. If the standardized speed was 6500 RPM (common for PWM blowers) and parameter 662 was set to 3.5%, then the blower speed could deviate up to +/- 227 RPM without causing the LMV3 to pause modulation.

Figure 5-7 below shows a VSD blower ramping down (decelerating) during operation. The exact same principles that applied to the VSD blower ramping up apply to the ramp down; however, inertia effects and a lack of braking typically cause a more non-linear response when ramping down.

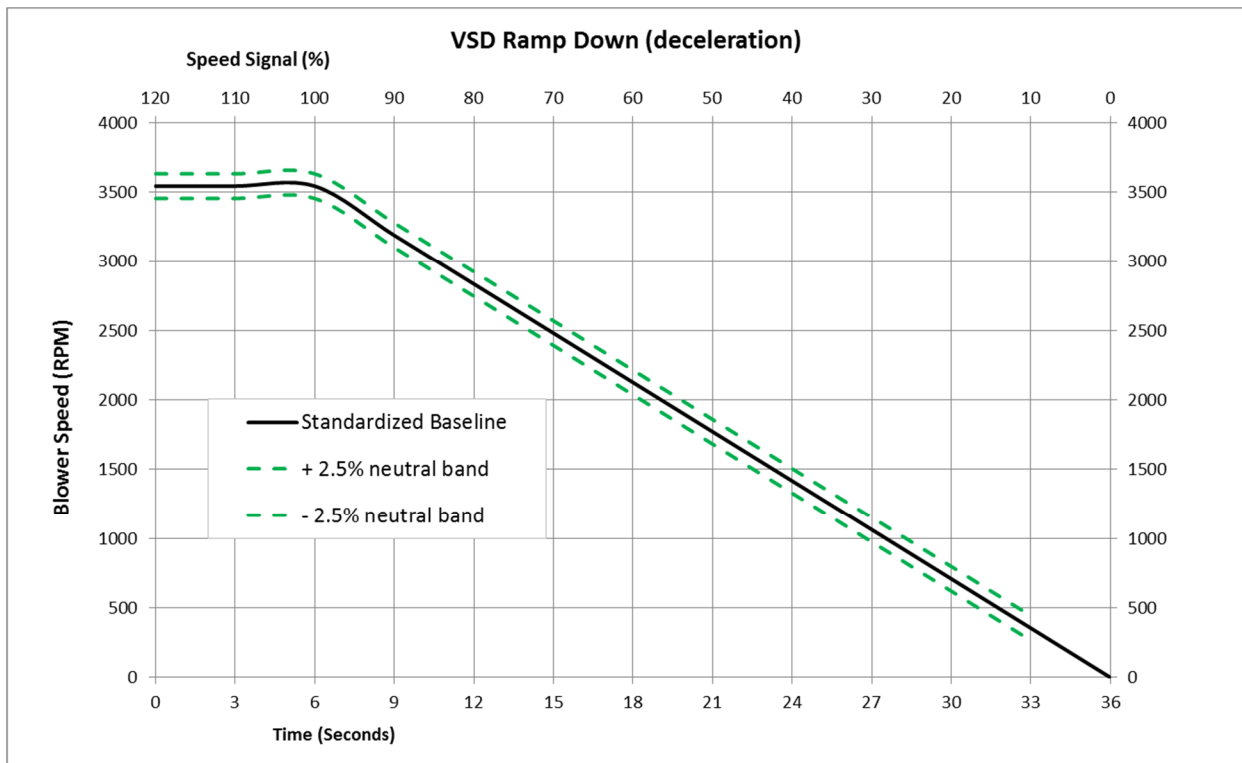

Figure 5-7: VSD Blower Speed Response during Deceleration

NOTE: Absolute minimum speed for VSD Blowers controlled by the LMV3 is 10% of the standardized speed.

Suggested Setup Procedure for the VSD Control – Parallel Positioning Application

After verifying that all VSD blower-related components are installed and wired correctly, the LMV3 control can be programmed for the VSD blower application. Naturally, this must be done before the Ratio Control Curves are commissioned.

This procedure will cover two types of VSD. Setup of a variable frequency drive (VFD) with a three phase motor will be covered, as well as a brushless DC (PWM) blower.

Prerequisites

For three phase motors with a VFD:

- The arrow on the speed wheel must point in the same direction as the correct blower rotation.
- The gap between the inductive speed sensor and the speed wheel finger is correct (approx. 1/16").
- The VFD, motor, and LMV3 share a common ground.
- The analog signal from the LMV3 to the VFD must be in shielded cable with one end of the shield grounded.
- The VFD is programmed correctly (see “Configuring VFDs for use with the LMV3”) earlier in this section for guidance.

For brushless DC blowers (PWM blowers):

- Ensure that the PWM blower is a closed loop type, meaning that it is utilizing an on-board speed control properly tuned for that specific blower.
- Ensure that the maximum closed loop speed that the PWM blower is programmed for is adequate for the application.
- Ensure the wiring is correct, paying particular attention to the low voltage wiring. Some PWM blowers have their electronics internally powered from the high voltage, while others require separate, external low voltage power.

After these points are double-checked, the LMV3 parameters can be set for the application.

1. Set the VSD ramp times.
 - a. Ramp up = Parameter 522
 - b. Ramp down = Parameter 523
 - c. Modulation ramp = Parameter 544

These ramp times must be set at least 10% longer than the capabilities of the connected VSD. For example, if the VSD can ramp up is 25 seconds, then parameter 522 must be set to at least 27 seconds. The same logic applies for the ramp down, parameter 523. The modulation ramp has a minimum setting of 32 seconds. If parameters 522 or 523 are more than 32 seconds, match the setting of parameter 544 to the longer ramp time which will be the value of 522 or 523.

2. Determine if separate ramping of VSD and air damper is necessary when driving from pre-purge to ignition. If separate ramping is used, the air damper stays at pre-purge position while the VSD ramps down to ignition position. This has a braking effect on the blower, and is very useful for PWM blowers and VFD without braking resistors. The disadvantage is a slightly longer start up time.

RECOMMENDATION: If a PWM blower or a VFD without a braking resistor is being used, set parameter 529 to 2, which utilizes the separate ramping and also allows for 50% more speed tolerance before the main fuel valves are open.

3. Set parameter 542 to 1, which activates the VSD control functionality in the LMV3. This is necessary for any type of VSD that will be used with the LMV3.
4. Determine the type of speed feedback (tachometer) that will be used with the LMV3. When the VSD is part of a non-pneumatic parallel positioning burner control, speed feedback is required.
 - a. For VFD with three phase blowers that utilize a speed wheel kit for speed feedback, set parameter 643 to 0, which indicates an asymmetric pulse pattern that matches the speed wheel kit. This speed wheel kit also produces 3 pulses per revolution, so ensure that parameter 644 is set to 3.
 - b. For PWM blowers that utilize the internal Hall Effect sensors, set parameter 643 to 1, which indicates an equally spaced symmetric pulse pattern. A symmetric pulse pattern is used by most PWM blower manufacturers. The number of pulses per revolution varies by model and manufacturer, but is typically 2 or 3 pulses per revolution. Determine the number of pulses per revolution, and set parameter 644 for this number. Parameter 644 can be set for 1 to 6 pulses per revolution.
5. Determine if it is permissible for the blower wheel to coast from post purge speed down to home position speed, which is typically 0% VSD. If the blower wheel is permitted to coast, the LMV3 will take slightly longer to get to home position which may be a concern if the burner needs to come back on immediately.

RECOMMENDATION: If a PWM blower or a VFD without a braking resistor is being used, set parameter 653 to 0, allowing the VSD to coast down after post purge. Setting parameter 653 to 1 will ramp the VSD to home position more quickly, but may also cause VSD issues if braking is not used.

6. Set parameter 661 to activate or deactivate the LMV3 internal speed control.
 - a. For VFDs with three phase blowers, parameter 661 is typically set to 1, which keeps the LMV3 internal speed control activated.
 - b. For PWM blowers, especially those utilizing a properly tuned onboard speed control, parameter 661 is typically set to 0, which turns off the speed control inside the LMV3.

-
7. Set the VSD blower speed monitoring bands to values that are safe for the application. See complete explanation of these bands detailed earlier in this section
 - a. VFDs with three phase blowers are typically more accurate from a speed control standpoint, especially if a vector type of VFD is used. For a vector type VFD driving a three phase blower, the neutral band (parameter 662) and the near band (parameter 663) can typically be left at their lowest values of 662 = 0.5% and 663 = 2%. If the application in question does not require fuel-to-air ratio control that is this precise, the neutral band and the near band can be increased. Maximum values of 662 = 3.5% and 663 = 5.5% are seldom needed if a VFD and three phase blower are functioning properly.
 - b. PWM blowers are somewhat less accurate from a speed control standpoint, but still have adequate accuracy for most applications. When using a PWM blower, the neutral band (parameter 662) and the near band (parameter 663) are typically set at values of 662 = 2.5% and 663 = 4.5%, assuming that it is safe to have this amount of fuel-to-air ratio control variance in the application. Maximum values of 662 = 3.5% and 663 = 5.5% are occasionally needed for PWM blowers if they are not correctly programmed for the application.
 8. Set the pre-purge position of the air actuator, which is typically the same as the high fire position of the air actuator. This is set with either parameter 502, index 01 for fuel 0, or parameter 505, index 01 for fuel 1.
 9. Ensure that the safety loop is closed, and that the main power is turned on to the VSD. Also ensure that the burner switch is off. Start the standardization procedure by setting parameter 641 to 1. See complete explanation of the standardization procedure earlier in this section.
 10. After the standardization is completed successfully, parameter 641 will return to 0 and "OFF UPR" will be displayed on the AZL. If a value appears other than 0, see Error Code 82 in Section 6 of this manual for the cause of the error.
 11. If desired, the standardized speed that was recorded during the standardization procedure can be viewed under parameter 642, index 01 and index 02.
 12. After the standardization has been completed successfully, the VSD is now ready to run and the fuel-to-air ratio curves can be set.

Suggested Setup Procedure for the VSD Speed Shift

The LMV3 also features a VSD speed shift, which enables the VSD speed curve to be shifted up or down a limited amount at any point on the fuel-to-air ratio control curve. This feature enables the LMV3 to accept a 4-20mA signal from an external device to shift the VSD speed, which “trims” the fuel-to-air ratio.

This VSD speed shift is typically used to trim the fuel-to-air ratio in response to burner intake air temperature and / or %O₂ in the burner exhaust. Taking this into consideration, an external controller that reads burner intake air temperature and / or %O₂ in the burner exhaust and outputs a 4-20mA signal to the LMV3 is typically used to command the VSD speed shift. Hard limits on the VSD speed shift are programmable in the LMV3 so that a partial or complete failure of the 4-20mA signal will not cause an unsafe fuel-to-air ratio.

The 4-20mA signal can also be used to shift the ignition speed of the VSD, so that the ignition point can be made richer or leaner if desired.

The following pages detail how to set up and use the VSD speed shift on the LMV3.

Prerequisites

- If the 4-20mA analog input is employed for speed shift, it cannot be used for load control. When the 4-20mA signal is employed for speed shift, the firing rate command must be sent to the LMV3 in a different way. For the LMV36, the firing rate must be controlled via Modbus. For the LMV37, the firing rate must be controlled via Modbus or a floating bumping (3 point) signal.
- The fuel-to-air ratio control curves must be fully commissioned (see Section 4 – Commissioning) before the VSD speed shift is activated. Care must be taken to allow for enough “room” at P1 and at P9 for the VSD speed shift. For example, if +/- 10% VSD speed shift will be used, P1 low fire cannot be lower than 20% VSD (10% is the absolute minimum setting for the VSD) and P9 high fire cannot be higher than 90% VSD (100% is the absolute maximum setting for the VSD).
- When commissioning the fuel-to-air ratio control curves, a linear increase in fuel flow from low fire (P1) to high fire (P9) is highly recommended, especially if the VSD speed shift will be used for O₂ trim.

After these points are considered, the LMV3 parameters can be set for the application.

1. Set the expected amount of speed shift. This can be changed at any point in time, even with the burner running, so if the exact value is not known a conservative approach (smaller magnitude number) is recommended. Note that the percentages set here are a percentage of the standardized speed. For a standardized speed of 3544 RPM, a 4% VSD shift would equate to 141 RPM. On an LMV36, these shifts can be configured for each fuel.
 - a. VSD Shift High (increase VSD speed) = parameter 548 for Fuel 0, parameter 568 for Fuel 1
 - b. VSD Shift Low (decrease VSD speed) = parameter 547 for Fuel 0, parameter 567 for Fuel 1

The range for VSD shift high is 0 to 25%, and the range for VSD shift low is 0 to -15%.

The amount of speed shift is related to the analog signal according to Figure 5-8 below:

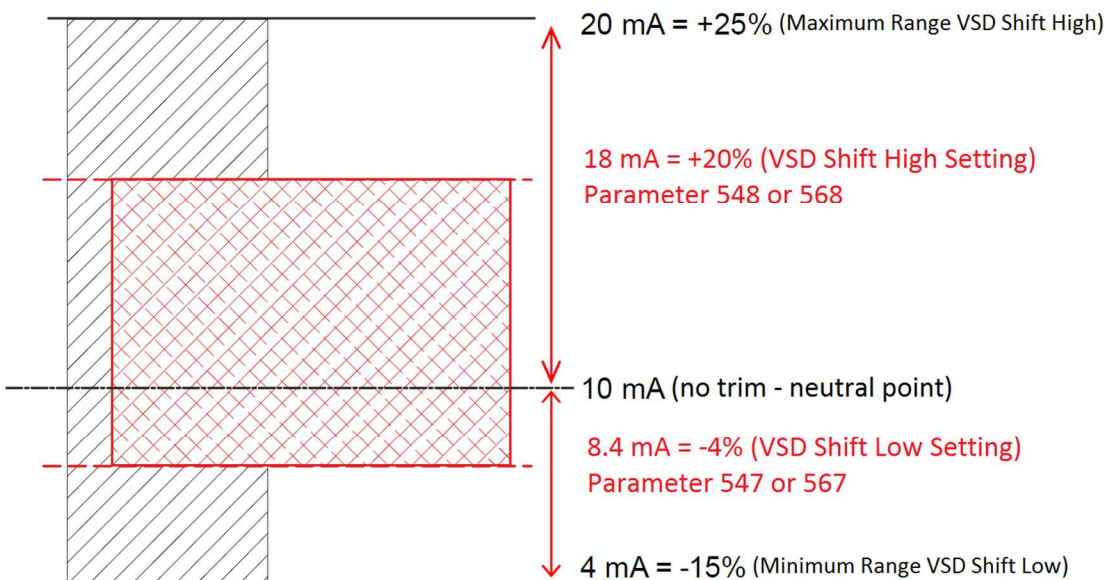

Ratio : 0.4mA is always equal to 1% VSD speed shift - based on 16mA = 40% Total VSD speed shift

Figure 5-8: VSD Speed Shift – Analog Signal to % VSD Trim

Looking at the figure above, 10mA is the neutral point for the VSD shift. A signal of 10mA will not cause any type of VSD speed shift off of the VSD curve. This neutral point of 10mA is not adjustable.

The VSD Shift High and the VSD Shift Low are independently adjustable so that they may be tailored to the application and to the ambient conditions when the fuel-to-air ratio curves are commissioned.

Changing the VSD Shift High and the VSD Shift Low values limits the amount of trim. This is done by cutting down the range of the 4-20mA signal, not re-spanning the 4-20mA signal. In other words, each 0.4mA of signal change will always equal 1% VSD trim. This relationship always holds true and is completely independent of the setting of VSD Shift High and VSD Shift Low.

2. Set the VSD shift attenuation. This parameter is used to limit the amount of VSD shift at points lower than high fire (P9). A setting of 100% means maximum shift attenuation (there will be no shift at low fire and maximum shift at high fire). A setting of 0% means no shift attenuation (the amount of shift at any point (P1 thru P9) will be the same as is commanded by the 4-20mA signal). This can also be changed at any point in time, even with the burner running, so if the exact value is not known a conservative approach (a higher value) is recommended.
 - a. VSD Shift Attenuation = parameter 549 for Fuel 0, parameter 569 for Fuel 1
 3. Set the VSD shift delay. This parameter is used to delay the VSD shift after ignition. The timing for this parameter starts after the LMV3 reaches phase 60. If the ignition speed shift is also being used, the amount of VSD shift used for ignition will be retained until this delay times out. This delay can be used to give the O₂ sensor time to obtain a valid reading after light off, or it can be used to run the burner rich for a set period of time after ignition to heat up the burner mesh or combustion chamber. The range is 0 to 255 seconds.
 - a. VSD Shift Delay = parameter 550 for Fuel 0, parameter 570 for Fuel 1
 4. Set the Shift Limit Response. This parameter determines the reaction of the LMV3 when the shift limits (VSD Shift Low and VSD Shift High) are reached. Three options are available (0 = warning only, 1 = warning and VSD shift deactivation, 2 = burner shutdown).
 - a. Shift Limit Response = parameter 552 for Fuel 0, parameter 572 for Fuel 1
 5. Set the Shift Limit Time. This parameter serves as a buffer timer for the selected Shift Limit Response. Whichever action is selected by the Shift Limit Response, this will delay that action for the set amount of time. The range is 0-3600 seconds (60 minutes). A setting of 0 will deactivate the feature.
 - a. Shift Limit Time = parameter 551 for Fuel 0, parameter 571 for Fuel 1
 6. Set the LMV3 response for an out of range (invalid) 4-20mA signal. Three options are available (0 = no VSD speed shift (warning message displayed), 1 = lockout, 2 = no VSD speed shift (warning message displayed)).
 - a. Invalid Analog In = parameter 204
 7. Now that the VSD speed shift is configured, it can be activated. Five different options are available (0 = deactivated, 1 = activated, 2 = activated with analog input test, 3 = activated with ignition speed shift, 4 = activated with analog input test and ignition speed shift).
 - a. VSD Speed Shift = parameter 530
-

When set to Options 1 or 2 (activated or activated with analog input test), the VSD speed will be shifted from the base VSD curve using the 4-20mA analog signal. This shift will occur when the LMV3 reaches phase 60, and the shift delay (parameter 550/570) has timed out. The shift will remain in effect until the end of phase 62 when the fuel valves close. Note that if the 4-20mA analog signal stays at 10mA, no shift will be observed.

When set to Options 3 or 4 (activated with ignition speed shift or activated with analog input test and ignition speed shift), the VSD speed will be shifted from the base VSD curve using the 4-20mA analog signal. With these options, the shift has two parts. The first part is the ignition speed shift, which is determined by the 4-20mA signal applied to the LMV3 during the end of phase 30 (pre-purge). Once the LMV3 leaves phase 30, this amount of speed shift will be locked in for ignition position (P0). This amount of speed shift will continue until the LMV3 reaches phase 60, and the shift delay (parameter 550/570) has timed out. After this timeout, the LMV3 will respond to the current 4-20mA analog signal and shift the VSD speed accordingly.

Just like the previous modes, the shift will remain in effect until the end of phase 62 when the fuel valves close. Note that if the 4-20mA analog signal stays at 10mA, no shift will be observed.

Options 2 and 4 add an analog input test to the functionality stated above. The analog input test is an added requirement that must be satisfied on each start up so that the correct functionality of the PLC or other device can be verified by the LMV3. The analog input test consists of the PLC or other device sending a 10mA signal to the LMV3 in standby (phase 12) and a 4mA signal during traveling to pre-purge (phase 24) for the first 2 seconds of pre-purge (phase 30). This would be accomplished by the PLC or other device reading the LMV3 phase over Modbus, and then generating the appropriate analog signal to match the phase.

8. After the VSD speed shift is activated, it is highly recommended to test the VSD shift settings, especially if the settings are unproven for the application. This can be done by varying the 4-20mA analog signal to the LMV3, and carefully approaching the VSD Shift High and VSD Shift Low limits. This test should be done at each point (P1 – low fire, P2, P3, P4, up to P9 – high fire) to ensure that the VSD Shift High and VSD Shift Low limits are safe for the application and that an unsafe fuel-to-air ratio will not occur at these shift limits. It is also very likely that the VSD shift attenuation (parameter 549/569) will need to be adjusted, since most applications require less VSD shift at low fire to achieve a certain fuel-to-air ratio.
9. If ignition speed shift is utilized (Options 3 or 4), this should also be tested at VSD Shift High and VSD Shift Low limits to ensure safe fuel-to-air ratios at light-off.

NOTE: It is the responsibility of the technician commissioning the VSD speed shift to ensure safe fuel-to-air ratios at all points (P0 to P9) for the settings of VSD Shift High (parameter 548/568), VSD Shift Low (parameter 547/567) and VSD Shift Attenuation (parameter 549/569). If settings of these parameters are unproven for the application, tests at the VSD shift limits at each point (P0 to P9) must be done.

Additional Tips for Burners with VSD Speed Shift

- The VSD speed shift occurs rather slowly. The rate at which the shift occurs is 1% VSD shift every 2 seconds until the targeted shift is reached. If the VSD speed shift is used as part of an O₂ trim system, this must be taken into account.
- As an alternative to activating the analog input test, a PLC or other device can be set up to read back the amount of VSD trim via LMV3 Modbus register 148, thereby creating closed loop feedback on the VSD speed shift system. If the PLC or other device detects a problem with what is being fed back over this register, the PLC or other device can take corrective action (adjust signal, shut down, or lockout the burner, etc.)
- If the PLC or other device that is sending the 4-20mA VSD speed shift command to the LMV3 has a PI (Proportional + Integral) loop linking the speed shift command to a measured value and a set point, PI “windup” is a concern. If the PLC or other device is up against one of the LMV3 trim limits unknowingly, PI windup is almost a certainty. To address this issue, additional Modbus registers have been added so that the PLC or other device can read back the trim limits programmed into the LMV3. These registers are: 144 – Lower trim limit Fuel 0, 145 – Upper trim limit Fuel 0, 146 – Lower trim limit Fuel 1, 147 – Upper trim limit Fuel 1
- The ignition speed shift is typically used to make the fuel-to-air ratio more fuel rich at light off and during the transition from light off (P0) to low fire (P1). Running the burner richer typically helps burner stability, especially when the burner head and / or combustion chamber is cold.

Additional Tips for Burners with VSD Control

- Most of the time, speed faults that are seen on the LMV3 are caused by the VFD not being able to decelerate the blower quickly enough when the blower is being ramped down. If fast ramp times are not critical for the application, ramp times can be increased and this should correct the issue. If fast ramp times are necessary, a braking resistor or other means of braking may be required to achieve the fast ramp down times.
- The LMV3 in combination with the VSD can be tested to check for proper operation while the LMV3 is in standby, phase 12. After the VSD is successfully standardized, the home position of the VSD can be adjusted with parameter 503 or 506, index 00. The actual speed in RPM can be read back on parameter 935. If different % VSD speeds are set (503 or 506) and plotted vs. the actual speed (935), the linearity of the VSD speed response can be assessed.
- The absolute speed as read in real time by the LMV3 can be viewed at any point during operation using parameter 935. Many other parameters that are useful for troubleshooting are also contained in the 900-level parameters.
- The ACS410 PC software has a trending package that is very useful when diagnosing VSD speed control issues. In particular, the commanded speed and the actual speed can be plotted against one another real time, and can be accurately reviewed to see where the largest deviations occur.
- The combustion air pressure switch should be set by taking the VSD to 10% below the lowest anticipated low fire speed (if low fire is 50%, take the VSD to 40%) and setting the switch to open at that point. This should maximize the safety potential of the combustion air pressure switch and minimize nuisance air pressure trips. This can be done in standby by setting the home position of the VSD to 10% lower than low fire and adjusting the switch to trip at this point.
- In most applications with an air damper, there is little reason to decrease blower speed below about 50% VSD (30 Hz for VFD). Power consumption decreases by the cube of the RPM even without the additional restriction of an air damper. Referencing information from the "Centrifugal Blower Fundamentals" section on the previous pages, decreasing the speed of a 25 HP (18.62 kW) motor from 3600 RPM (60 Hz) to 1800 RPM (30 Hz) will cause the power consumption to be reduced from 18.62 kW down to 2.32 kW, an electrical savings of over 800%.
- A VSD alone without an air damper or sliding head offers limited accuracy and repeatability for the airflow at higher burner turndowns. For most boiler burners, modulating the VSD alone without an air damper is okay for turndowns of 4-to-1 or less. Using only a VSD for airflow regulation at higher turndowns may lead to airflow repeatability issues.

Section 1	Overview
Section 2	Wiring
Section 3	Parameters
Section 4	Commissioning
Section 5	VSD
Section 6	Troubleshooting
Section 7	Modbus
Section 8	ACS410
Appendix A	Application Guide

Section 1	Overview
Section 2	Wiring
Section 3	Parameters
Section 4	Commissioning
Section 5	VSD
Section 6	Troubleshooting
Section 7	Modbus
Section 8	ACS410
Appendix A	Application Guide

6-1: Troubleshooting Introduction

The LMV3 has an extensive list of fault codes to help clarify the nature of any fault. Section 6-2 describes every fault code in detail and gives guidance on how to correct it.

When a lockout occurs, the AZL will alternate between displaying “Loc:c” and “Loc:d”. The number listed after “Loc:c” is the error code, and the number listed after “Loc:d” is the diagnostic code. For example, an error code 3, diagnostic code 0 will alternate between displaying “Loc:c: 3” and “Loc:d: 0”.

If a fault occurs that does not cause a lockout, the AZL will alternate between displaying “InF:c” and “InF:d”. The number listed after “InF:c” is the error code, and the number listed after “InF:d” is the diagnostic code. These faults are intended to provide the user information even though a lockout did not occur.

The fault history is stored in the 700 set of parameters. The LMV3 stores the last 25 fault codes:

Parameter 701 displays information about the current status of the LMV3.

Parameter 702 displays information about the most recent fault.

Parameter 703 displays information about the second most recent fault.

...

Parameter 725 displays information about the 24th most recent fault.

Each fault code listed has indexes that provide additional information about the fault:

Index 01 = Error code

Index 02 = Diagnostic code

Index 03 = Error class (not used in North America)

Index 04 = Phase

Index 05 = Start number

Index 06 = Load

Index 07 = Fuel (LMV36 only)

Often, index 05 and index 06 will display a value of “._.”. This means that the AZL display ran out of room to display the start number or load. When this happens, hold down the info button to display the value.

An example of how the AZL displays a fault code in the fault history is shown below:



Figure 6-1: LMV3 Fault History Example with Indexes

6-2: Complete Error Code List

Error Code	Diag. Code	Meaning for the LMV3 System	Corrective Action
Note: Diagnostic codes are additive. If a diagnostic code appears that is not on this list, it is a combination of multiple diagnostic codes.			
no Comm	-	No communication between the LMV3 and the AZL23	Check for a loose connection between the LMV3 and AZL23. If the connection is good, replace the cable connecting the LMV3 to the AZL23. If that does not fix the issue, replace the AZL23.
2	Any #	No flame at the end of safety time (TSA)	<p>A flame failure occurred during lightoff.</p> <ol style="list-style-type: none"> 1. Check the wiring of the ignition transformer, pilot valve, and main valve(s). 2. Check manual shutoff valves for the pilot gas and main gas. 3. Check the position of the air damper and close it further if necessary. The pilot flame might be getting blown out. 4. Check the flame detector signal in the presence of a known flame source. Replace the flame detector if it does not produce the anticipated signal.
	1	No flame at the end of safety time 1 (TSA1)	
	2	No flame at the end of safety time 2 (TSA2)	
	4	No flame at the end of safety time 1 (TSA1) (software version ≤ V02.00)	
3	Any #	Air pressure failure	A fault occurred related to the air pressure switch input X3-02.1. See diagnostic codes for more information.
	0	Air pressure off	The air pressure switch input was de-energized when it should have been energized. Make sure the blower starts in phase 22 and the switch setpoint is set appropriately.
	1	Air pressure on	The air pressure switch input was energized when it should have been de-energized. Make sure the blower turns off in phase 78 and the switch setpoint is set appropriately. If necessary, increase the setting of parameter 213.
	2	Evaluation of air pressure	Check the setting of parameter 235/335. This can only be set to 2 on pneumatic fuel train options.
	4	Air pressure on - prevention of startup	The air pressure switch input is energized, preventing the LMV3 from starting up. If other inputs besides the air pressure switch input are in the wrong state, causing a start prevention, the diagnostic code calls out what other inputs are in the wrong state.
	20	Air pressure, combustion pressure - start prevention	
	68	Air pressure, POC - start prevention	
	84	Air pressure, combustion pressure, POC - start prevention	

Error Code	Diag. Code	Meaning for the LMV3 System	Corrective Action
Note: Diagnostic codes are additive. If a diagnostic code appears that is not on this list, it is a combination of multiple diagnostic codes.			
4	Any #	Extraneous light	An extraneous light (flame signal present when input should be de-energized) fault occurred. 1) Ensure that the source of light is not a flame. If it is, take corrective action immediately. 2) Ambient light can cause an extraneous light fault. Ensure the flame scanner is viewing a dark area such as the inside of a boiler. 3) UV scanners typically fail on (give a false flame signal). Remove UV flame scanner and cover the bulb to ensure it is not seeing any light. Check parameter 954 to see if the LMV3 is registering a flame signal. If it is, replace the UV scanner. Diagnostic code 2 - A call for heat was received, but the LMV3 will not start up due to an extraneous light fault. Diagnostic codes 6 and higher - A call for heat was received, but the LMV3 will not start up due to an extraneous light fault. Other inputs besides the flame signal input are in the wrong state as well. The diagnostic code calls out what other inputs are in the wrong state.
	0	Extraneous light during startup	
	1	Extraneous light during shutdown	
	2	Extraneous light during startup - prevention of startup	
	6	Extraneous light during startup, air pressure - start prevention	
	18	Extraneous light during startup, combustion pressure - start prevention	
	24	Extraneous light during startup, air pressure, combustion pressure - start prevention	
	66	Extraneous light during startup, POC - start prevention	
	70	Extraneous light during startup, air pressure, POC - start prevention	
	82	Extraneous light during startup, combustion pressure, POC - start prevention	
86	Extraneous light during startup, air pressure, combustion pressure, POC - start prevention		
7	Any #	Loss of flame	1) Increase the setting of parameter 186:01 (fuel 0) or 187:01 (fuel 1). This increases the FFRT. A maximum setting of 30 equals a 4 second FFRT. 2) Check the flame detector signal in the presence of a known flame source. Replace the flame detector if it does not produce the anticipated signal.
	0	Loss of flame	
	3	Loss of flame (software version ≤ V02.00)	
	3-255	Loss of flame due to TUV test (loss of flame test)	
12	Any #	Valve proving	A fault occurred related to valve proving. See diagnostic codes for more information.
	0	Fuel valve 2 (V2) leaking	The downstream gas valve failed valve proving with the low gas switch doubling as the valve proving switch (parameter 236 = 2). See diagnostic code 83 for corrective action.
	1	Fuel valve 1 (V1) leaking	The upstream gas valve failed valve proving with the low gas switch doubling as the valve proving switch (parameter 236 = 2). See diagnostic code 81 for corrective action.
	2	Valve proving not possible	Valve proving is activated, but no input is assigned for the valve proving switch.
	3	Valve proving not possible	

Error Code	Diag. Code	Meaning for the LMV3 System	Corrective Action
Note: Diagnostic codes are additive. If a diagnostic code appears that is not on this list, it is a combination of multiple diagnostic codes.			
12	4	Valve proving not possible	Valve proving is activated, but multiple inputs are assigned for the valve proving pressure switch (parameter 236/336 = 2 and parameter 237/337 = 3). Change parameter 236/336 to a 1.
	5	Valve proving not possible	
	81	Fuel valve 1 (V1) leaking	The upstream gas valve failed valve proving: 1) Bubble test the gas valve to ensure the valve is not leaking. If the valve is leaking, replace the valve. 2) Ensure that the setpoint of the valve proving pressure switch is set to 50% of the inlet pressure to the upstream valve.
	83	Fuel valve 2 (V2) leaking	The downstream gas valve failed valve proving: 1) Bubble test the gas valve to ensure the valve is not leaking. If the valve is leaking, replace the valve. 2) Ensure that the setpoint of the valve proving pressure switch is set to 50% of the inlet pressure to the upstream valve.
14	Any #	POC	A fault occurred related to a proof-of-closure (POC) switch. See diagnostic codes for more information.
	0	POC open	The POC input X5-02.2 is open when it should be closed: 1) If no POC switches are being used, change setting of parameter 237. 2) Check wiring to the fuel valves. Ensure fuel valves are wired to the correct terminal (see Section 2 for wiring diagrams). With the manual shutoff valves closed, ensure that the fuel valves are closing in the proper phase (see Section 3 for sequence diagrams). 3) Ensure POC switches are closing when the valve closes. If this does not happen, check wiring, adjust switches, or replace fuel valve actuator.
	1	POC closed	The POC input X5-02.2 is closed when it should be open: 1) If no POC switches are being used, change setting of parameter 237. 2) Check wiring to the fuel valves. Ensure fuel valves are wired to the correct terminal (see Section 2 for wiring diagrams). With the manual shutoff valves closed, ensure that the fuel valves are opening in the proper phase (see Section 3 for sequence diagrams). 3) Ensure POC switches are opening when the valve opens. If this does not happen, check wiring, adjust switches, or replace fuel valve actuator.
	64	POC open - prevention of startup	The POC input X5-02.2 was open when a call for heat was received, preventing the LMV3 from starting up. See diagnostic code 0 for corrective actions.

Error Code	Diag. Code	Meaning for the LMV3 System	Corrective Action
Note: Diagnostic codes are additive. If a diagnostic code appears that is not on this list, it is a combination of multiple diagnostic codes.			
18	Any #	Air pressure failure (speed-dependent air pressure switch)	A fault occurred related to the speed-dependent air pressure switch. See diagnostic codes for more information.
	0	Air pressure switch off	When using a speed-dependent air pressure switch, the switch must be closed anytime the VSD speed is greater than the setting of parameter 671.
	1	Air pressure switch on	When using a speed-dependent air pressure switch, the switch must be open anytime the VSD speed is less than the setting of parameter 670.
	128	Invalid parameterization	Check the settings of parameters 670 and 671. Parameter 671 must be set to a higher value than parameter 670.
19	80	Combustion pressure, POC - start prevention	Check wiring and operation of combustion pressure switch.
20	Any #	Pressure switch-min (Pmin)	A fault occurred related to the low gas pressure switch. See diagnostic codes for more information.
	0	No minimum gas pressure	The low gas pressure switch (input X5-01.2) opened, causing a fault. Check gas supply and open any manual shutoff valves. Check the setpoint and wiring of the low gas pressure switch.
	1	Gas shortage / prevention of startup	The low gas pressure switch was not made by the end of phase 22, preventing the startup of the LMV3. See diagnostic code 0 for more corrective actions.
21	Any #	Pressure switch-max (Pmax) / POC	A fault occurred related to the high gas or oil pressure switch (or POC if using an LMV3 with a software version \leq V02.00). See diagnostic codes for more information.
	0	Pressure switch-max (Pmax): Maximum gas / oil pressure exceeded. POC: POC open (software version \leq V02.00)	The high gas / oil pressure switch (input X5-02.2) opened, causing a fault. Check the setpoint and wiring of the high gas / oil pressure switch. Check pressure regulators for ruptured diaphragms. If using an LMV3 with a software version \leq V02.00, this could be a POC fault if parameter 237 is set for 2. If so, see corrective action of error code 14, diagnostic 0.
	1	POC closed (software version \leq V02.00)	Only appears if using an LMV3 with a software version \leq V02.00: See corrective action of error code 14, diagnostic 1.
	64	POC open - start prevention (software version \leq V02.00)	Only appears if using an LMV3 with a software version \leq V02.00: See corrective action of error code 14, diagnostic 64.

Error Code	Diag. Code	Meaning for the LMV3 System	Corrective Action
Note: Diagnostic codes are additive. If a diagnostic code appears that is not on this list, it is a combination of multiple diagnostic codes.			
22 OFF S	Any #	Safety loop / burner flange	<p>A safety loop / burner flange fault occurred. Check all of the switches wired into the safety loop (between terminals X3-04.1 and X3-04.2). This also includes the burner flange circuit (between terminals X3-03.1 and X3-03.2). One of the switches must have opened, causing the fault. Fix the condition that caused the switch to open and reset the fault.</p> <p>Diagnostic code 1 - A call for heat was received, but the LMV3 will not start up due to a safety loop / burner flange fault.</p> <p>Diagnostic codes 3 and larger - A call for heat was received, but the LMV3 will not start up due to a safety loop / burner flange fault. Other inputs besides the safety loop and burner flange inputs are in the wrong state as well. The diagnostic code calls out what other inputs are in the wrong state.</p>
	0	Safety loop / burner flange open	
	1	Safety loop / burner flange open / prevention of startup	
	3	Safety loop / burner flange open, extraneous light - start prevention	
	5	Safety loop / burner flange open, air pressure - start prevention	
	7	Safety loop / burner flange open, extraneous light, air pressure - start prevention	
	17	Safety loop / burner flange open, combustion pressure - start prevention	
	19	Safety loop / burner flange open, extraneous light, combustion pressure - start prevention	
	21	Safety loop / burner flange open, air pressure, combustion pressure - start prevention	
	23	Safety loop / burner flange open, extraneous light, air pressure, combustion pressure - start prevention	
	65	Safety loop / burner flange open, POC - start prevention	
	67	Safety loop / burner flange open, extraneous light, POC - start prevention	
	69	Safety loop / burner flange open, air pressure, POC - start prevention	
	71	Safety loop / burner flange open, extraneous light, air pressure, POC - start prevention	
81	Safety loop / burner flange open, combustion pressure, POC - start prevention		
83	Safety loop / burner flange open, extraneous light, combustion pressure, POC - start prevention		
85	Safety loop / burner flange open, air pressure, combustion pressure, POC - start prevention		
87	Safety loop / burner flange open, extraneous light, air pressure, combustion pressure, POC - start prevention		

Error Code	Diag. Code	Meaning for the LMV3 System	Corrective Action
Note: Diagnostic codes are additive. If a diagnostic code appears that is not on this list, it is a combination of multiple diagnostic codes.			
23	Any #	Gas pressure switch-min (Pmin) / heavy oil direct start	A low gas pressure or heavy oil direct start fault occurred. See diagnostic codes for more information.
	0	No minimum gas pressure	The low gas pressure switch (input X5-01.2) opened, causing a fault. Check gas supply and open any manual shutoff valves. Check the setpoint and wiring of the low gas pressure switch. Check the setting of parameter 285/385.
	1	Gas shortage - start prevention	The low gas pressure switch was not made by the end of phase 38, preventing the startup of the LMV3. See diagnostic code 0 for more corrective actions.
	2	Heavy oil direct start	When firing heavy oil, the heavy oil direct start input (X9-04.2) was de-energized, causing the fault. Check the setting of parameter 286, and verify the wiring of the heavy oil direct start is correct.
50	Any #	Internal error	If the fault occurs continuously, replace the LMV3.
51	Any #	Internal error	
55	Any #	Internal error	
56	Any #	Internal error	
57	Any #	Internal error	
58	Any #	Internal error	
60	Any #	Internal error: No valid load controller source	No valid 4-20 mA signal is present on terminal X64. This could be done on purpose to create a low fire hold. Otherwise, check wiring of 4-20 mA signal and ensure 4-20 mA source is valid. See diagnostic codes for more information.
	0	Internal error: No valid load controller source	Reset the fault. If the fault occurs continuously, replace the LMV3.
	1	Analog output preset valid - prevention of startup	No valid 4-20 mA signal is present on terminal X64 and parameter 204 is set to 1, causing the lockout. Re-establish a valid 4-20 mA signal and reset the fault.
	2	Analog output preset valid - default output low-fire	No fault: No valid 4-20 mA signal is present on terminal X64 and parameter 204 is set to 0, so the LMV3 is operating at low fire. The fault message appears to alert the user that a low fire hold is enabled. To enable modulation, re-establish a valid 4-20 mA signal.

Error Code	Diag. Code	Meaning for the LMV3 System	Corrective Action
Note: Diagnostic codes are additive. If a diagnostic code appears that is not on this list, it is a combination of multiple diagnostic codes.			
61 Fuel Chg	Any #	Fuel changeover	No fault: The LMV36 is currently in the process of changing fuels. See diagnostic codes for more information.
	0	Fuel 0	No fault: The LMV36 is currently in the process of changing from fuel 1 to fuel 0.
	1	Fuel 1	No fault: The LMV36 is currently in the process of changing from fuel 0 to fuel 1.
62 Fuel Err	Any #	Invalid fuel signals / fuel information	On an LMV36, either fuel 0 must be selected via line voltage on terminal X5-03.2 or fuel 1 must be selected via line voltage on terminal X5-03.3. If neither or both of these terminals are energized at the same time, a fault will occur. See diagnostic codes for more information.
	0	Invalid fuel selection (Fuel 0 + 1 = 0)	On an LMV36, neither fuel is selected. Either select fuel 0 (apply voltage to terminal X5-03.2) or fuel 1 (apply voltage to terminal X5-03.3).
	1	Different fuel choice between the μ Cs	If the fault occurs continuously, replace the LMV3.
	2	Different fuel signals between the μ Cs	
3	Invalid fuel selection (Fuel 0 + 1 = 1)	On an LMV36, both fuels are selected. Remove voltage from either terminal X5-03.2 (fuel 0) or terminal X5-03.3 (fuel 1).	
65	Any #	Internal error	If the fault occurs continuously, replace the LMV3.
66	Any #	Internal error	
67	Any #	Internal error	
70	Any #	Internal error fuel-air ratio control: Position calculation modulating	Check curve points to see if correct values have been entered for all actuators and the VSD. Readjust the ratio curve if required.
	23	Output invalid	
	26	Curvepoints undefined	

Error Code	Diag. Code	Meaning for the LMV3 System	Corrective Action
Note: Diagnostic codes are additive. If a diagnostic code appears that is not on this list, it is a combination of multiple diagnostic codes.			
71	Any #	Special position undefined	A special position (home, prepurge, ignition, or postpurge) is undefined for one of the actuators / VSD See diagnostic codes for more information.
	0	Home position	The home position for one of the actuators / VSD is undefined. Check the settings of index 00 for parameters 501 through 506. Change any settings that are undefined and reset the fault.
	1	Prepurge position	The prepurge position for one of the actuators / VSD is undefined. Check the settings of index 01 for parameters 501 through 506. Change any settings that are undefined and reset the fault.
	2	Postpurge position	The postpurge position for one of the actuators / VSD is undefined. Check the settings of index 02 for parameters 501 through 506. Change any settings that are undefined and reset the fault.
	3	Ignition position	The ignition position for one of the actuators / VSD is undefined. Enter commissioning mode (parameter 400) and check the settings of P0. Change any settings that are undefined and reset the fault.
72	Any #	Internal error fuel-air ratio control	If the fault occurs continuously, replace the LMV3.
73	Any #	Internal error fuel-air ratio control: Position calculation multistep	Check curve points to see if correct values have been entered for all actuators and the VSD. Readjust the ratio curve if required.
	23	Output invalid	
	26	Curvepoints undefined	
75	Any #	Internal error fuel-air ratio control: Data clocking check	1) Set both parameter 123:00 and 123:01 to a 1 and reset the fault. 2) If the fault persists, and a VSD is present, restandardize the VSD and reset the fault. 3) If the fault occurs continuously, replace the LMV3.
	1	Current output different	
	2	Target output different	
	4	Target positions different	
	6	Target output and target positions different	
16	Different positions reached		
76	Any #	Internal error fuel-air ratio control	If the fault occurs continuously, replace the LMV3.

Error Code	Diag. Code	Meaning for the LMV3 System	Corrective Action
Note: Diagnostic codes are additive. If a diagnostic code appears that is not on this list, it is a combination of multiple diagnostic codes.			
80	Any #	Control range limitation of VSD	A VSD speed error occurred. See diagnostics codes for more information.
	1	Control range limitation at the bottom	This indicates that the LMV3 has decreased its signal to the VSD as much as possible and the motor RPM is still too high. 1) Increase VSD / LMV3 ramp times. 2) Increase VSD braking if possible. 3) Ensure that the VSD and LMV3 are configured for the same analog signal (0-10 VDC). 4) Re-standardize the speed. Be sure to check combustion after the re-standardization.
	2	Control range limitation at the top	This indicates that the LMV3 has increased its signal to the VSD as much as possible and the motor RPM is still too low. 1) Increase VSD / LMV3 ramp times. 2) Check for filters, damping, or delays on the input signal to the VSD. The VSD should respond to the input signal in a linear fashion. 3) Check speed sensor on motor for correct installation, especially the gap between the sensor and the speed wheel. 4) Ensure that the VSD and LMV3 are configured for the same analog signal (0-10 VDC). 5) Re-standardize the speed. Be sure to check combustion after the re-standardization.
81	1	Interrupt limitation speed input	The LMV3 has detected an interruption on the speed input. Decrease the electrical noise on the speed sensor wires. If the fault occurs continuously, replace the LMV3.
82	Any #	Error during VSD's speed standardization	An error occurred while attempting to standardize the speed of the VSD. See diagnostic codes for more information.
	1	Timeout of standardization (VSD ramp down time too long)	Standardization timed out because the VSD took too long to ramp down at the end of the standardization. Either decrease the ramp down time in the VSD or increase the setting of parameter 523.
	2	Storage of standardized speed not successful	Press the info button with any other button to cause a manual lockout, then reset the fault and attempt to standardize again.

Error Code	Diag. Code	Meaning for the LMV3 System	Corrective Action
Note: Diagnostic codes are additive. If a diagnostic code appears that is not on this list, it is a combination of multiple diagnostic codes.			
82	3	Line interruption speed sensor	No pulses from the speed sensor were detected during standardization. 1) Verify that the motor is rotating. 2) Check the wiring between the speed sensor and the LMV3. 3) Check and / or adjust the gap between the speed wheel and the sensor. The gap should be about 1/16" (2mm), or about two turns away from the speed wheel.
	4	Speed variation / VSD ramp up time too long / speed below minimum limit for standardization	A stable speed was not reached after ramping up the VSD, so a standardized speed could not be determined. 1) Either decrease the ramp up time in the VSD or increase the setting of parameter 522. 2) Check for filters, damping, or delays on the input signal to the VSD. The VSD should respond to the input signal in a linear fashion. 3) Ensure that the VSD and LMV3 are configured for the same analog signal (0-10 VDC).
	5	Wrong direction of rotation	1) Check to see if the motor's direction of rotation is correct. Reverse if necessary. 2) Check to see if the arrow on the speed wheel points in the correct direction of rotation. Reverse if necessary.
	6	Unplausible sensor signals	1) Check the setting of parameter 643 and ensure it is set correctly. For VSD + 3-phase motor, this should be a 0. For most brushless DC blowers, this should be a 1. 2) Check and / or adjust the gap between the speed wheel and the sensor. The gap should be about 1/16" (2mm), or about two turns away from the speed wheel. 3) Check the wiring of the speed sensor. Ensure the reference ground is properly connected. 4) Ensure that other metal parts besides the speed wheel are not being picked up by the sensor when the motor rotates.
	7	Invalid standardized speed	The standardized speed measured does not lie in the permissible range (650-14,000 RPM).
	15	Speed deviation $\mu C1 + \mu C2$	Reset the fault and repeat the standardization.

Error Code	Diag. Code	Meaning for the LMV3 System	Corrective Action
Note: Diagnostic codes are additive. If a diagnostic code appears that is not on this list, it is a combination of multiple diagnostic codes.			
82	20	Wrong phase of phase manager	Standardization must be performed in standby (phase 12).
	21	Safety loop / burner flange open	Fix any conditions causing a limit in the safety loop / burner flange circuit to be open, then attempt to standardize again.
	22	Air actuator not referenced	Typically caused by trying to standardize while the air actuator is currently referencing. Wait for the actuator to finish referencing and try to standardize again. If the fault persists, see error code 85, diagnostic code 1 for additional troubleshooting.
	23	VSD deactivated	The VSD must be activated before standardization can be performed. Set parameter 542 to a 1 and attempt to standardize again.
	24	No valid operation mode	A fuel train must be selected before standardization can be performed. Select a fuel train via parameter 201 (fuel 0) or 301 (fuel 1), then attempt to standardize again.
	25	Pneumatic air-fuel ratio control	Standardization cannot be performed when using a pneumatic fuel train. Select a different fuel train via parameter 201 (fuel 0) or 301 (fuel 1), then attempt to standardize again.
	128	Running command with no preceding standardization	A call for heat was received and the VSD is activated (parameter 542 = 1), but no standardization has been performed. Perform a standardization by setting parameter 641 to a 1 while in standby phase 12, or deactivate the VSD by setting parameter 542 to 0.
	255	No standardized speed available	Perform a standardization by setting parameter 641 to 1 while in standby (phase 12).
83	Any #	Speed error VSD	A VSD speed error occurred. See diagnostics codes for more information.
	1	Lower control range limitation of control	See error code 80, diagnostic code 1.
	2	Upper control range limitation of control	See error code 80, diagnostic code 2.
	4	Interruption via disturbance pulses	See error code 81, diagnostic code 1.
	8	Curve too steep in terms of ramp speed	See error code 84.
	16	Interruption of speed signal	No speed signal was detected. 1) Ensure that the motor is rotating. If it is not, check the wiring of the VSD / PWM blower. 2) If using a VSD, turn the motor by hand to ensure that the LED on the speed sensor lights up when it sees the speed wheel. If it does not, decrease gap between speed wheel and speed sensor and check the wiring of the speed sensor. If there are no issues, replace speed sensor.

Error Code	Diag. Code	Meaning for the LMV3 System	Corrective Action
Note: Diagnostic codes are additive. If a diagnostic code appears that is not on this list, it is a combination of multiple diagnostic codes.			
83	32	Quick shutdown due to excessive speed deviation	<p>The speed of the motor was more than 10% different than the anticipated speed for more than 1 second.</p> <ol style="list-style-type: none"> 1) Check the ramp times of the VSD and LMV3. Increase if necessary. The ramp times in the LMV3 should be at least 20% longer than the ramp times in the VSD. 2) Check the setting of parameter 661.
	64	VSD speed is below minimum speed (phase dependent)	<ol style="list-style-type: none"> 1) Standby (phase 12): Ensure parameter 669:01 (maximum speed) is set to a higher value than parameter 669:00 (minimum speed). 2) Standby (phase 12): Ensure parameter 663 (near zone) is set to a higher value than parameter 662 (neutral zone). 3) Check the absolute speed (parameter 935) to ensure the correct speed is being detected by the LMV3. 4) Prepurge (phase 30): The detected speed was below the minimum prepurge speed (parameter 667), or the setting of parameter 503:01 or 506:01 is below the setting of parameter 667. 5) Operation (phases 40-64): The detected speed was below the minimum operation speed (parameter 669:00), or a VSD curve point was set below the setting of parameter 669:00.
	128	VSD speed exceeds maximum speed (phase dependent)	<ol style="list-style-type: none"> 1) Standby (phase 12): Ensure parameter 226/266/326/366 is set to a higher value than parameter 665 (time outside near zone). 2) Standby (phase 12): Ensure parameter 669:01 (maximum speed) is set to a higher value than parameter 669:00 (minimum speed). 3) Standby (phase 12): Ensure parameter 663 (near zone) is set to a higher value than parameter 662 (neutral zone). 4) Check the absolute speed (parameter 935) to ensure the correct speed is being detected by the LMV3. 5) Ignition (phase 38): The detected speed was above the maximum ignition speed (parameter 668), or the VSD speed setting of P0 is above the setting of parameter 668. 6) Operation (phases 40-64): The detected speed was above the maximum operation speed (parameter 669:01), or a VSD curve point was set above the setting of parameter 669:01.
	255	Failed forced travel test	<p>If the LMV3 remains at the same fire rate for an extended period of time, a minimal load change is forced, and the corresponding feedback from the PWM blower is checked. If this fault occurs, the PWM blower speed change was insufficient in response to the load change.</p>

Error Code	Diag. Code	Meaning for the LMV3 System	Corrective Action
Note: Diagnostic codes are additive. If a diagnostic code appears that is not on this list, it is a combination of multiple diagnostic codes.			
84	Any #	Curve slope actuators	The difference in position between two adjacent curve points is too large. See diagnostic code for which actuator / VSD has positions that are too far apart. For actuators, either increase the setting of parameter 544, or decrease the distance between curve points. For VSD, either increase the setting of parameter 544, decrease the setting of parameters 522 and 523, decrease the distance between curve points, or decrease parameter 647.
	1	VSD: Curve too steep in terms of ramp speed	
	2	Fuel actuator: Curve too steep in terms of ramp rate	
	4	Air actuator: Curve too steep in terms of ramp rate	
85	Any #	Referencing error on actuators	All SQM33... actuators must travel outside of their 0-90° operating range before starting up the burner in order to "reference" their position. This fault means that the referencing was unsuccessful. 1) Check the setting of parameter 601 (fuel 0) and 608 (fuel 1). Index 00 sets the fuel actuator reference direction and index 01 sets the air actuator reference direction. 2) Check to make sure the actuators are not binding when trying to reference (ensure that overstroking below 0° or above 90° is possible). 3) Check the setting of parameter 613 (fuel 0) and 614 (fuel 1) to ensure the actuator type is set correctly. 4) Make sure that the actuator's are plugged into the correct terminal on the LMV3.
	0	Referencing error of fuel actuator	
	1	Referencing error of air actuator	
	128	Referencing error due to parameter change	
86	Any #	Error fuel actuator	An error occurred pertaining to the fuel actuator. See diagnostic codes for more information. Verify that the valve connected to the fuel actuator is not bound. Ensure that the torque requirements of the valve are less than the output of the fuel actuator. If everything checks out okay, replace the SQM33 actuator. Check the wiring between the fuel actuator and LMV3 terminal X54. Fix the wiring error and reset the fault. If no fuel actuator exists, choose a fuel train option (parameter 201/301) that does not require a fuel actuator. See error code 84.
	0	Position error	
	1	Line interruption	
	8	Curve too steep in terms of ramp rate	

Error Code	Diag. Code	Meaning for the LMV3 System	Corrective Action
Note: Diagnostic codes are additive. If a diagnostic code appears that is not on this list, it is a combination of multiple diagnostic codes.			
86	16	Step deviation in comparison with last referencing	The fuel actuator is bound. 1) Check the setting of parameter 613:00 (fuel 0) and 614 (fuel 1) to ensure the actuator type is set correctly. 2) Check to see if the actuator gets bound somewhere along its working range. This can be done changing the home position of the actuator in standby (no alarm). 3) Ensure that the torque of the actuator is sufficient for the application.
87	Any #	Error air actuator	An error occurred pertaining to the air actuator. See diagnostic codes for more information.
	0	Position error	Verify that the valve / damper connected to the air actuator is not bound. Ensure that the torque requirements of the valve / damper are less than the output of the air actuator. If everything checks out okay, replace the SQM33 actuator.
	1	Line interruption	Check the wiring between the air actuator and LMV3 terminal X53. Fix the wiring error and reset the fault. If no air actuator exists, choose a fuel train option (parameter 201/301) that does not require an air actuator.
	8	Curve too steep in terms of ramp rate	See error code 84.
	16	Step deviation in comparison with last referencing	The air actuator is bound. 1) Check the setting of parameter 613:01 to ensure the actuator type is set correctly. 2) Check to see if the actuator gets bound somewhere along its working range. This can be done changing the home position of the actuator in standby (no alarm). 3) Ensure that the torque of the actuator is sufficient for the application.
90	Any #	Internal error basic unit	If the fault occurs continuously, replace the LMV3.
91	Any #	Internal error basic unit	
93	Any #	Error flame signal acquisition	Check the wiring of the QRB... flame detector and reset the fault. If the fault occurs continuously, replace the QRB... flame detector.
	3	Short-circuit of sensor	

Error Code	Diag. Code	Meaning for the LMV3 System	Corrective Action
Note: Diagnostic codes are additive. If a diagnostic code appears that is not on this list, it is a combination of multiple diagnostic codes.			
95	Any #	Error relay supervision	Check for voltage feeding back on the output given by the diagnostic code. Fix the wiring error / defective component causing the voltage feedback and reset the fault.
	3	External power supply NO contact (ignition transformer - X4-02.3)	
	4	External power supply NO contact (fuel valve 1 - X8-02.1)	
	5	External power supply NO contact (fuel valve 2 - X7-01.3)	
	6	External power supply NO contact (pilot valve - X7-02.3)	
96	Any #	Error relay supervision	Remove the wire from fan output terminal X3-05.1 and perform the following two tests: 1. With power connected to the LMV3 and the LMV3 in standby, ensure there is no voltage on fan output X3-05.1. 2. With no power connected to the LMV3, ensure there is no continuity between fan output X3-05.1 and neutral.
	3	Relay contacts have welded (ignition transformer)	
	4	Relay contacts have welded (fuel valve 1)	
	5	Relay contacts have welded (fuel valve 2)	
	6	Relay contacts have welded (pilot valve)	
97	Any #	Error relay supervision	If either test fails, replace the LMV3. If both tests are passed, reset the fault.
	0	Safety relay contacts have welded or external power supply fed to safety relay	
98	Any #	Error relay supervision	If the fault occurs continuously, replace the LMV3.
	2	Relay does not pull in (safety valve - X6-03.3)	
	3	Relay does not pull in (ignition transformer - X4-02.3)	
	4	Relay does not pull in (fuel valve 1 - X8-02.1)	
	5	Relay does not pull in (fuel valve 2 - X7-01.3)	
	6	Relay does not pull in (pilot valve - X7-02.3)	
99	Any #	Internal error relay control	If the fault occurs continuously, replace the LMV3.
	3	Internal error relay control	On software version V03.10, if this error occurs during standardization of the VSD, temporarily deactivate the alarm in the case of start prevention (set parameter 210 = 0), reset the fault, and re-standardize. Otherwise, if the fault occurs continuously, replace the LMV3.
100	Any #	Internal error relay control	If the fault occurs continuously, replace the LMV3.

Error Code	Diag. Code	Meaning for the LMV3 System	Corrective Action
Note: Diagnostic codes are additive. If a diagnostic code appears that is not on this list, it is a combination of multiple diagnostic codes.			
105	Any #	Internal error contact sampling	<p>1. Check the connections of the neutrals to all of the connected switches, valves, etc.</p> <p>2. The diagnostic code determines which terminal on the LMV3 has an issue. Check for inductive loads that cause voltage to be present on the terminal after the LMV3 de-energizes the terminal. If voltage exists on an output terminal, such as a fuel valve, after the LMV3 de-energizes the terminal, it will cause a fault. Voltage must drop to zero on the terminal within about 10 ms after the terminal is de-energized.</p>
	0	Stuck-at failure (pressure switch-min - X5-01.2)	
	1	Stuck-at failure (pressure switch-max / POC - X5-02.2)	
	2	Stuck-at failure (pressure switch valve proving - X9-04.2)	
	3	Stuck-at failure (air pressure - X3-02.1)	
	4	Stuck-at failure (fuel selection fuel 1 - X5-03.3)	
	5	Stuck-at failure (load controller on / off - X5-03.1)	
	6	Stuck-at failure (fuel selection fuel 0 - X5-03.2)	
	7	Stuck-at failure (safety loop / burner flange - X3-04.1, X3-03.1)	
	8	Stuck-at failure (safety valve - X6-03.3)	
	9	Stuck-at failure (ignition transformer - X4-02.3)	
	10	Stuck-at failure (fuel valve 1 - X8-02.1)	
	11	Stuck-at failure (fuel valve 2 - X7-01.3)	
	12	Stuck-at failure (pilot valve - X7-02.3)	
13	Stuck-at failure (reset - X8-04.1)		
106	Any #	Internal error contact request	If the fault occurs continuously, replace the LMV3.
107	Any #	Internal error contact request	
108	Any #	Internal error contact request	
110	Any #	Internal error voltage monitor test	
111	Any #	Power failure	Mains voltage is too low. The mains voltage must be 102-132 VAC. Once the mains voltage returns to the required range, error code 112 will be triggered. Reset the LMV3. Note: After recovering from this fault, the fault history will only show error code 112, and the error code 111 will not be shown.
112	0	Mains voltage recovery	No fault: This code is triggered when mains voltage recovers after being too low (see error code 111).
113	Any #	Internal error mains voltage supervision	If the fault occurs continuously, replace the LMV3.
115	Any #	Internal error system counter	
116	0	Designed lifetime exceeded (250,000 startups)	The LMV3 will still operate, but this fault cannot be reset and internal parts of the LMV3 have exceeded their designed lifetime. It is recommended to replace the LMV3.

Error Code	Diag. Code	Meaning for the LMV3 System	Corrective Action
Note: Diagnostic codes are additive. If a diagnostic code appears that is not on this list, it is a combination of multiple diagnostic codes.			
117	0	Lifetime exceeded - operation no longer allowed	Replace the LMV3.
120	0	Interrupt limitation fuel meter input	The LMV3 has detected too many disturbance pulses at the fuel meter input. Reduce electrical noise and reset the fault.
121	Any #	Internal error EEPROM access	Reset the fault and check to make sure the last parameter that was viewed / changed is set properly. Restore the parameter set if possible. If the fault occurs continuously, replace the LMV3.
122	Any #	Internal error EEPROM access	
123	Any #	Internal error EEPROM access	
124	Any #	Internal error EEPROM access	
125	Any #	Internal error EEPROM read access	Reset the fault and check to make sure the last parameter that was viewed / changed is set properly. If the fault occurs continuously, replace the LMV3.
126	Any #	Internal error EEPROM write access	
127	Any #	Internal error EEPROM access	Reset the fault and check to make sure the last parameter that was viewed / changed is set properly. Restore the parameter set if possible. If the fault occurs continuously, replace the LMV3.
128	0	Internal error EEPROM access - synchronization during initialization	If the fault occurs continuously, replace the LMV3.
129	Any #	Internal error EEPROM access - command synchronization	Reset the fault and check to make sure the last parameter that was viewed / changed is set properly. If the fault occurs continuously, replace the LMV3.
130	Any #	Internal error EEPROM access - timeout	
131	Any #	Internal error EEPROM access - page on abort	
132	Any #	Internal error EEPROM register initialization	If the fault occurs continuously, replace the LMV3.
133	Any #	Internal error EEPROM access - request synchronization	Reset the fault and check to make sure the last parameter that was viewed / changed is set properly. If the fault occurs continuously, replace the LMV3.
134	Any #	Internal error EEPROM access - request synchronization	
135	Any #	Internal error EEPROM access - request synchronization	
136	Any #	Restore	No fault: A restore was started via parameter 050. New LMV3s require a reset after a restore. Reset the LMV3.
	1	Restore started - for further diagnostic codes, refer to error code 137	

Error Code	Diag. Code	Meaning for the LMV3 System	Corrective Action
Note: Diagnostic codes are additive. If a diagnostic code appears that is not on this list, it is a combination of multiple diagnostic codes.			
137	Any #	Internal error - backup / restore	An error occurred while attempting to perform a backup or restore via parameter 050. See diagnostic codes for more information.
	157 (-99)	Restore - ok, but backup < data set of current system	No fault: Restore was successful, but the backup data record is smaller than in the current system.
	239 (-17)	Backup - storage of backup in AZL23 faulty	Reset the fault and repeat the backup.
	240 (-16)	Restore - no backup in AZL23	There is no parameter set stored in the AZL23, so the restore process could not be completed. Reset the fault.
	241 (-15)	Restore - abortion due to unsuitable product no. (ASN)	The parameter set stored in the AZL23 has an unsuitable product no. (ASN), so the restore process was aborted. Reset the fault.
	242 (-14)	Backup - backup made is inconsistent	The backed up parameter set is faulty and cannot be transferred back to the LMV3. Reset the fault.
	243 (-13)	Backup - data comparison between μ Cs faulty	Reset the fault and repeat the backup.
	244 (-12)	Backup data are incompatible	The parameter set stored in the AZL23 is not compatible with the LMV3 software version, so the restore could not be completed. Reset the fault.
	245 (-11)	Access error to parameter Restore_Complete	Reset the fault and repeat the restore.
	246 (-10)	Restore - timeout when storing in EEPROM	Reset the fault and repeat the restore.
	247 (-9)	Data received are inconsistent	Some data in the parameter set stored in the AZL23 is invalid, so the restore could not be completed. Reset the fault.
	248 (-8)	Restore cannot at present be made	Reset the fault and repeat the restore.
	249 (-7)	Restore - abortion due to unsuitable burner identification	The parameter set stored in the AZL23 has an unsuitable burner identification and must not be transferred to the LMV3. Reset the fault and do not attempt the restore again.
	250 (-6)	Backup - CRC of one page is not correct	The restore was not possible because the backup data record is invalid. Reset the fault.
	251 (-5)	Backup - burner identification is not defined	A valid burner ID (parameter 113) is required to perform a backup. Set the burner ID, reset the fault, and start the backup again.
	252 (-4)	After restore, pages still on ABORT	Reset the fault and repeat the restore.
253 (-3)	Restore cannot at present be made	Reset the fault and repeat the restore.	
254 (-2)	Abortion due to transmission error	Reset the fault and repeat the restore.	
255 (-1)	Abortion due to timeout during backup / restore	Communication between the LMV3 and AZL23 was interrupted during the backup or restore. Re-establish communication and reset the fault. If the fault continues, it is possible the AZL23 is too old and does not support the backup / restore functions. If this is the case, replace the AZL23.	

Error Code	Diag. Code	Meaning for the LMV3 System	Corrective Action
Note: Diagnostic codes are additive. If a diagnostic code appears that is not on this list, it is a combination of multiple diagnostic codes.			
146	Any #	Timeout building automation interface	Modbus communication has been interrupted for longer than the setting of parameter 142. Re-establish communication, then reset the fault.
	1	Modbus timeout	
	2	Reserved	
150	Any #	TUV test	A fault occurred during the TUV test. See diagnostic codes for more information.
	1 (-1)	Invalid phase	The TUV test can only be started in phase 60 (operation). Reset the fault. When the LMV3 reaches phase 60, attempt to start the TUV test again.
	2 (-2)	TUV test default output too low	The TUV test default output (parameter 133/134) cannot be set lower than the lower load limit (parameter 545/565). Either increase the TUV test default output or decrease the lower load limit, then reset the fault.
	3 (-3)	TUV test default output too high	The TUV test default output (parameter 133/134) cannot be set higher than the upper load limit (parameter 546/566). Either decrease the TUV test default output or increase the upper load limit, then reset the fault.
	4 (-4)	Manual interruption	No fault: The TUV test was aborted manually by the user.
	5 (-5)	TUV test timeout	There was no loss of flame after shutdown of the fuel valves. Check for extraneous light or a faulty flame scanner, then reset the fault and start the TUV test again.
154	Any #	Trim function: Invalid analog value	An invalid 4-20 mA signal was detected on input X64. Check the wiring to terminal X64. Check the value of parameter 916. A value under -16% indicates <4 mA is being detected, while a value over 26% indicates >20 mA is being detected.
	1	Start prevention	
	2	Warning (trim function temporarily disabled)	
155	Any #	Trim function: Invalid curve setting of VSD / PWM blower	The following equations set the limits on the curve settings for the VSD / PWM blower. Fuel 0: Parameter 669:00 + parameter 547 ≤ curve point ≤ parameter 669:01 - parameter 548 Fuel 1: Parameter 669:00 + parameter 567 ≤ curve point ≤ parameter 669:01 - parameter 568
	1-9	Minimum value VSD curve invalid	A VSD curve point is below the permissible minimum value (diagnostic code = point number, example: 1 = point P1)
	21-29	Maximum value VSD curve invalid	A VSD curve point is above the permissible maximum value (diagnostic code = point number, example: 21 = point P1)
	41-49	Fuel 1: Minimum value VSD curve invalid	Fuel 1: A VSD curve point is below the permissible minimum value (diagnostic code = point number, example: 41 = point P1)
	61-69	Fuel 1: Maximum value VSD curve invalid	Fuel 1: A VSD curve point is above the permissible maximum value (diagnostic code = point number, example: 61 = point P1)

Error Code	Diag. Code	Meaning for the LMV3 System	Corrective Action
Note: Diagnostic codes are additive. If a diagnostic code appears that is not on this list, it is a combination of multiple diagnostic codes.			
156	Any #	Trim function: Maximum time for trim limit exceeded	A trim limit was met for the maximum allowable time. See diagnostic codes for more information.
	0	Lower limit trim function	The VSD trim signal was lower than allowed by the minimum trim limit (parameter 547) for a time period longer than the maximum time allowed (parameter 551).
	1	Upper limit trim function	The VSD trim signal was higher than allowed by the maximum trim limit (parameter 548) for a time period longer than the maximum allowed (parameter 551).
	10	Fuel 1: Lower limit trim function	The VSD trim signal was lower than allowed by the minimum trim limit (parameter 567) for a time period longer than the maximum time allowed (parameter 571).
	11	Fuel 1: Upper limit trim function	The VSD trim signal was higher than allowed by the maximum trim limit (parameter 568) for a time period longer than the maximum allowed (parameter 571).
157	Any #	Trim function: Failed the analog input test	A fault occurred during the analog input test. See diagnostic codes for more information.
	0	Analog value standby	If the analog input test is enabled, the LMV3 looks for 12mA to be present on terminal X64 during standby. Check parameter 916 to ensure that the input signal lies in the permissible range of -1%...+1%. Setting parameter 530 to a value other than 2 or 4 disables the analog input test.
	1	Analog value prevention	If the analog input test is enabled, the LMV3 looks for 4mA to be present on terminal X64 during prepurge. Check parameter 916 to ensure that the input signal lies in the permissible range of -16%...-14%. Setting parameter 530 to a value other than 2 or 4 disables the analog input test.
165	Any #	Internal error	If the fault occurs continuously, replace the LMV3.
166	0	Internal error watchdog reset	

Error Code	Diag. Code	Meaning for the LMV3 System	Corrective Action
Note: Diagnostic codes are additive. If a diagnostic code appears that is not on this list, it is a combination of multiple diagnostic codes.			
167	Any #	Manual locking	The LMV3 has been manually locked (no fault). Reset the LMV3 to clear the fault.
	1	Manual locking by contact	
	2	Manual locking by AZL23	
	3	Manual locking by PC software	During a curve adjustment on the AZL23, the timeout for menu operation has elapsed (parameter 127), or communication between the LMV3 and AZL23 has been lost. Re-establish communication and reset the fault.
	8	Manual locking by AZL23 - timeout / communication breakdown	
	9	Manual locking by PC software - communication breakdown	
	33	Manual locking by PC software - test of lockout	A reset was made via the ACS410 software when the LMV3 was not in alarm. Reset the LMV3 to clear the fault.
168	Any #	Internal error management	If the fault occurs continuously, replace the LMV3.
169	Any #	Internal error management	
170	Any #	Internal error management	
171	Any #	Internal error management	
200 OFF	Any #	System error-free	The LMV3 displays this code when there are no current faults.
201 OFF UPr0 OFF Upr1	Any #	Prevention of startup	The LMV3 cannot startup because a parameter is not defined. The diagnostic code calls out which parameter is not defined. Choose a valid selection for the undefined parameter and then reset the fault.
	1	No operating mode selected	
	2	No fuel train defined	
	4	No curves defined	
	8	Standardized speed undefined	
	16	Backup / restore was not possible	
202	Any #	Internal error operating mode selection	Make a valid selection of parameter 201/301, then reset the fault.
203	Any #	Internal error	Make a valid selection of parameter 201/301, then reset the fault. If the fault occurs continuously, replace the LMV3.
204	24	Program stop is active (phase 24)	No fault: The program stop feature is active. Set parameter 208 to 0 to deactivate the program stop if it is no longer required.
	36	Program stop is active (phase 36)	
	44	Program stop is active (phase 44)	
	52	Program stop is active (phase 52)	
205	Any #	Internal error	If the fault occurs continuously, replace the LMV3.

Error Code	Diag. Code	Meaning for the LMV3 System	Corrective Action
Note: Diagnostic codes are additive. If a diagnostic code appears that is not on this list, it is a combination of multiple diagnostic codes.			
206	0	Inadmissible combination of units (LMV3 / AZL23)	Reset the LMV3. If the fault occurs continuously, replace the LMV3 and / or AZL23.
207	Any #	Version compatibility LMV3 / AZL23	Replace the unit called out in the diagnostic code. Be sure that the new unit has up-to-date software.
	0	LMV3 version is too old	
	1	AZL23 version is too old	
208	Any #	Internal error	If the fault occurs continuously, replace the LMV3.
209	Any #	Internal error	
210	0	Selected operation mode is not released for the LMV3	Select a different operation mode via parameter 201/301.
240	Any #	Internal error	If the fault occurs continuously, replace the LMV3.
242	Any #	Invalid parameterization	Make a valid selection of parameter 277/377, then reset the fault.
	0	Invalid setting of parameter 277	Set parameter 277 to a valid value.
	1	Invalid setting of parameter 377	Set parameter 377 to a valid value.
245	Any #	Internal error	If the fault occurs continuously, replace the LMV3.
250	Any #	Internal error	

Intentionally Left Blank

Section 1	Overview
Section 2	Wiring
Section 3	Parameters
Section 4	Commissioning
Section 5	VSD
Section 6	Troubleshooting
Section 7	Modbus
Section 8	ACS410
Appendix A	Application Guide

Section 1	Overview
Section 2	Wiring
Section 3	Parameters
Section 4	Commissioning
Section 5	VSD
Section 6	Troubleshooting
Section 7	Modbus
Section 8	ACS410
Appendix A	Application Guide

Section 7: Modbus

General

The physical connection to the Modbus system is made via an external OCI412.10 module.

Master-slave principle

Communication between Modbus users takes place according to the master-slave principle. The LMV3 always works as a slave. Every device on the bus line must be assigned a different address.

Data transmission

Modbus interface settings

In addition to the interface parameters that can be set on the LMV3 (parameters 141-149), the following parameters for the communication interface are already set:

Number of data bits	8
Number of start bits	1
Number of stop bits	1

Transmission mode (RTU)

- The transmission mode used is RTU (Remote Terminal Unit)
- Data is transmitted in a binary format (hexadecimal) with 8 bits
- The LSB (least significant bit) is transmitted first
- ASCII operating mode is not supported

Structure of data blocks

All data blocks use the same structure with the following four fields:

Slave Address	Function Code	Data Field	Checksum CRC16
1 byte	1 byte	x byte	2 bytes

Slave Address Device address of a certain slave

Function Code Function selection (reading / writing words)

Data Field Contains the following information:

- Word address
- Number of words
- Word value

Checksum Identification of transmission errors

Checksum (CRC16)

Transmission errors are detected with the help of the checksum (CRC16). If an error is detected during evaluation, the respective device will not respond.

Calculation scheme

CRC = 0xFFFF	
CRC = CRC XOR ByteOfMessage	
For (1 to 8)	
CRC = SHR (CRC)	
if (flag shifted to the right = 1)	
then	else
CRC = CRC XOR 0xA001	
while (not all ByteOfMessage edited)	



The low-byte of the checksum is transmitted first.

Example

Data inquiry: Reading 2 words from address 6 (CRC16 = 0x24A0)

0B	03	00	06	00	02	A0	24
						CRC16	

Reply: (CRC16 = 0x0561)

0B	03	04	00	00	42	C8	61	05
				Word 1		Word 2		CRC16

Mapping long values

Byte High	Byte Low	Byte High	Byte Low
Word Low		Word High	

Erroneous access to parameters of the LMV3

Reading When attempting to read non-existing parameters, a substitute value will be sent. The substitute value is fixed at 0xFFFF.

Writing When attempting to write to non-existing parameters, or to parameters disabled for building automation mode, the value of the parameter will not be changed and no response will be sent.

Temporal process of communication

Both beginning and end of a data block are characterized by transmission pauses. Between 2 successive characters, a maximum period of 3.5 times the character transmission time may elapse. The character transmission time (time required for the transmission of one character) is dependent on the Baud rate and the data format used.

Hence, in the case of a data format of 8 data bits, no parity bit, and one stop bit, the transmission time is calculated as follows:

$$\text{Character transmission time [ms]} = 1000 * 10 \text{ bits} / \text{Baud rate}$$

And with the other data formats:

$$\text{Character transmission time [ms]} = 1000 * 11 \text{ bits} / \text{Baud rate}$$

Process

Data inquiry from the master Transmission time = n characters * 1000 * x bits / Baud rate
Identification code for end of data inquiry 3.5 characters * 1000 * x bits / Baud rate
Handling of data inquiry by the slave
Reply from the slave Transmission time = n characters * 1000 * x bits / Baud rate
Identification code for end of reply 3.5 characters * 1000 * x bits / Baud rate

Example

Identification code for end of data inquiry or response in case of a data format 11 / 10 bits.

$$\text{Waiting time} = 3.5 \text{ characters} * 1000 * x \text{ bits} / \text{Baud rate}$$

Baud rate [Baud]	Data format [bit]	Waiting time [ms]
9600	11	4.01
	10	3.645

Temporal process of a data inquiry

Time scheme A data inquiry progresses according to the following scheme:

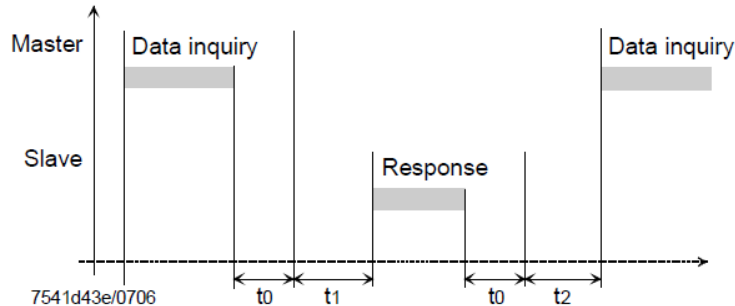

where:

- t_0 Identification code for the end = 3.5 characters
(time is dependent on the Baud rate)
- t_1 Dependent on the time required for internal handling.
The maximum handling time is dependent on the number of data.

In case of read access for 6 parameters: 50 ms
In case of write access for 2 parameters: 50 ms

- $t_2 \geq 50$ ms
This is the time required by the device to switch back from sending to receiving. It must be observed by the master before making a new data inquiry. It must always be observed, even if the new data inquiry is made to some other device.

Communication during the internal slave handling time

During the slave's internal handling time, the master must not make any data inquiries. Any inquiries made during this period of time will be ignored by the slave.

Communication during the slave's response time

During the time the slave responds, the master must not make any data inquiries. If inquiries are made during this period of time, all data currently on the bus become invalid.

Number of addresses per message

The number of addresses per message is limited:

- 20 addresses the size of a word when reading
- 6 addresses the size of a word when writing
- For fault history, messages must be exactly 8 or 16 addresses

Modbus functions

The following Modbus functions are supported:

Function number	Function
0x03 / 0x04	Reading n words
0x06	Writing one word
0x10	Writing n words

Requirements for the Modbus master

A Modbus system whose connection is based on RS485 is a robust system.

With regards to the possible cable lengths and the loads produced by the various users and environmental conditions, the master software should satisfy the following criteria:

- In the case of write processes, correct writing must be checked through back-reading
- In the case of read processes, it must be checked whether a reply from the slave is received. If there is no such reply, the inquiry must be repeated, or it must be checked whether an error occurred (wiring, valid Modbus address, etc.)

Modbus addresses

Overview table

Function	Address dec/hex	Number of words	Data designation	Access	Data format	Data type / coding	Range
03/04	0/0h	1	Burner control phase	R	U16		0...255
03/04	1/1h	1	Position of current fuel actuator	R	S16	Degrees	-50... 150°
03/04	4/4h	1	Position of air actuator	R	S16	Degrees	-50... 150°
03/04	8/8h	1	Manipulated variable VSD	R	S16	Percent	0...100 %
03/04	9/9h	1	Current type of fuel (default setting: 0)	R	U16	0= fuel 0 1= fuel 1	0...1
03/04	10/Ah	1	Current output	R	U16	Fire rate	Modulating: 0...100% Multistage: 1001...1003 Invalid: 32767
03/04	13/Dh	1	Flame signal	R	U16	Percent	0...100 %
03/04	14/0Eh	1	Current fuel throughput	R	U16	0..65535	0...6553.4 m ³ /h, L/h, ft ³ /h, g/h Error: 65535.5
03/04	21/15h	2	Startup counter total	R	S32		0...999999
03/04	25/19h	1	Current error: Error code	R	U16		0...255
03/04	26/1Ah	1	Current error: Diagnostic code	R	U16		0...255
03/04	27/1Bh	1	Current error: Error class	R	U16		0...6
03/04	28/1Ch	1	Current error: Error phase	R	U16		0...255

Function	Address dec/hex	Number of words	Data designation	Access	Data format	Data type / coding	Range																																																																																																																																	
03/04	35/23h	1	Inputs	R	U16	-	-																																																																																																																																	
Coding: 0 → inactive 1 → active																																																																																																																																								
<table style="width:100%; border:none;"> <tr> <td style="border:1px solid black; width:10%; text-align:center;">B15</td> <td style="border:1px solid black; width:10%; text-align:center;">B14</td> <td style="border:1px solid black; width:10%; text-align:center;">B13</td> <td style="border:1px solid black; width:10%; text-align:center;">B12</td> <td style="border:1px solid black; width:10%; text-align:center;">B11</td> <td style="border:1px solid black; width:10%; text-align:center;">B10</td> <td style="border:1px solid black; width:10%; text-align:center;">B9</td> <td style="border:1px solid black; width:10%; text-align:center;">B8</td> <td style="width:20%;"></td> <td style="border:1px solid black; width:10%; text-align:center;">B7</td> <td style="border:1px solid black; width:10%; text-align:center;">B6</td> <td style="border:1px solid black; width:10%; text-align:center;">B5</td> <td style="border:1px solid black; width:10%; text-align:center;">B4</td> <td style="border:1px solid black; width:10%; text-align:center;">B3</td> <td style="border:1px solid black; width:10%; text-align:center;">B2</td> <td style="border:1px solid black; width:10%; text-align:center;">B1</td> <td style="border:1px solid black; width:10%; text-align:center;">B0</td> </tr> <tr> <td style="padding-left: 20px;">B8</td> <td colspan="6">Safety loop (SK)</td> <td style="padding-left: 20px;">B0</td> <td colspan="6">Controller on/off</td> </tr> <tr> <td style="padding-left: 20px;">B9</td> <td colspan="6"></td> <td style="padding-left: 20px;">B1</td> <td colspan="6"></td> </tr> <tr> <td style="padding-left: 20px;">B10</td> <td colspan="6">Pressure switch-min (Pmin) (pressure switch valve proving (P LT) via pressure switch-min (Pmin))</td> <td style="padding-left: 20px;">B2</td> <td colspan="6"></td> </tr> <tr> <td style="padding-left: 20px;">B11</td> <td colspan="6">Pressure switch-max (Pmax) / POC</td> <td style="padding-left: 20px;">B3</td> <td colspan="6"></td> </tr> <tr> <td style="padding-left: 20px;">B12</td> <td colspan="6"></td> <td style="padding-left: 20px;">B4</td> <td colspan="6"></td> </tr> <tr> <td style="padding-left: 20px;">B13</td> <td colspan="6">Air pressure switch (LP)</td> <td style="padding-left: 20px;">B5</td> <td colspan="6"></td> </tr> <tr> <td style="padding-left: 20px;">B14</td> <td colspan="6"></td> <td style="padding-left: 20px;">B6</td> <td colspan="6"></td> </tr> <tr> <td style="padding-left: 20px;">B15</td> <td colspan="6"></td> <td style="padding-left: 20px;">B7</td> <td colspan="6">Pressure switch valve proving (P LT)</td> </tr> </table>								B15	B14	B13	B12	B11	B10	B9	B8		B7	B6	B5	B4	B3	B2	B1	B0	B8	Safety loop (SK)						B0	Controller on/off						B9							B1							B10	Pressure switch-min (Pmin) (pressure switch valve proving (P LT) via pressure switch-min (Pmin))						B2							B11	Pressure switch-max (Pmax) / POC						B3							B12							B4							B13	Air pressure switch (LP)						B5							B14							B6							B15							B7	Pressure switch valve proving (P LT)					
B15	B14	B13	B12	B11	B10	B9	B8		B7	B6	B5	B4	B3	B2	B1	B0																																																																																																																								
B8	Safety loop (SK)						B0	Controller on/off																																																																																																																																
B9							B1																																																																																																																																	
B10	Pressure switch-min (Pmin) (pressure switch valve proving (P LT) via pressure switch-min (Pmin))						B2																																																																																																																																	
B11	Pressure switch-max (Pmax) / POC						B3																																																																																																																																	
B12							B4																																																																																																																																	
B13	Air pressure switch (LP)						B5																																																																																																																																	
B14							B6																																																																																																																																	
B15							B7	Pressure switch valve proving (P LT)																																																																																																																																

Function	Address dec/hex	Number of words	Data designation	Access	Data format	Data type / coding	Range																																																																																																																																	
03/04	37/25h	1	Outputs	R	U16	-	-																																																																																																																																	
Coding: 0 → inactive 1 → active																																																																																																																																								
<table style="width:100%; border:none;"> <tr> <td style="border:1px solid black; width:10%; text-align:center;">B15</td> <td style="border:1px solid black; width:10%; text-align:center;">B14</td> <td style="border:1px solid black; width:10%; text-align:center;">B13</td> <td style="border:1px solid black; width:10%; text-align:center;">B12</td> <td style="border:1px solid black; width:10%; text-align:center;">B11</td> <td style="border:1px solid black; width:10%; text-align:center;">B10</td> <td style="border:1px solid black; width:10%; text-align:center;">B9</td> <td style="border:1px solid black; width:10%; text-align:center;">B8</td> <td style="width:20%;"></td> <td style="border:1px solid black; width:10%; text-align:center;">B7</td> <td style="border:1px solid black; width:10%; text-align:center;">B6</td> <td style="border:1px solid black; width:10%; text-align:center;">B5</td> <td style="border:1px solid black; width:10%; text-align:center;">B4</td> <td style="border:1px solid black; width:10%; text-align:center;">B3</td> <td style="border:1px solid black; width:10%; text-align:center;">B2</td> <td style="border:1px solid black; width:10%; text-align:center;">B1</td> <td style="border:1px solid black; width:10%; text-align:center;">B0</td> </tr> <tr> <td style="padding-left: 20px;">B8</td> <td colspan="6"></td> <td style="padding-left: 20px;">B0</td> <td colspan="6">Alarm (AL)</td> </tr> <tr> <td style="padding-left: 20px;">B9</td> <td colspan="6"></td> <td style="padding-left: 20px;">B1</td> <td colspan="6"></td> </tr> <tr> <td style="padding-left: 20px;">B10</td> <td colspan="6"></td> <td style="padding-left: 20px;">B2</td> <td colspan="6"></td> </tr> <tr> <td style="padding-left: 20px;">B11</td> <td colspan="6"></td> <td style="padding-left: 20px;">B3</td> <td colspan="6"></td> </tr> <tr> <td style="padding-left: 20px;">B12</td> <td colspan="6"></td> <td style="padding-left: 20px;">B4</td> <td colspan="6">Ignition (Z)</td> </tr> <tr> <td style="padding-left: 20px;">B13</td> <td colspan="6">Fuel valve 1 (V1)</td> <td style="padding-left: 20px;">B5</td> <td colspan="6"></td> </tr> <tr> <td style="padding-left: 20px;">B14</td> <td colspan="6">Fuel valve 2 (V2)</td> <td style="padding-left: 20px;">B6</td> <td colspan="6">Fan (M)</td> </tr> <tr> <td style="padding-left: 20px;">B15</td> <td colspan="6">Fuel valve 3 (V3) / pilot valve (PV)</td> <td style="padding-left: 20px;">B7</td> <td colspan="6"></td> </tr> </table>								B15	B14	B13	B12	B11	B10	B9	B8		B7	B6	B5	B4	B3	B2	B1	B0	B8							B0	Alarm (AL)						B9							B1							B10							B2							B11							B3							B12							B4	Ignition (Z)						B13	Fuel valve 1 (V1)						B5							B14	Fuel valve 2 (V2)						B6	Fan (M)						B15	Fuel valve 3 (V3) / pilot valve (PV)						B7						
B15	B14	B13	B12	B11	B10	B9	B8		B7	B6	B5	B4	B3	B2	B1	B0																																																																																																																								
B8							B0	Alarm (AL)																																																																																																																																
B9							B1																																																																																																																																	
B10							B2																																																																																																																																	
B11							B3																																																																																																																																	
B12							B4	Ignition (Z)																																																																																																																																
B13	Fuel valve 1 (V1)						B5																																																																																																																																	
B14	Fuel valve 2 (V2)						B6	Fan (M)																																																																																																																																
B15	Fuel valve 3 (V3) / pilot valve (PV)						B7																																																																																																																																	

Function	Address dec/hex	Number of words	Data designation	Access	Data format	Data type / coding	Range
R 03/04 W 06/16	38/26h	1	Program stop	R/W* EEPROM	U16	0=deactivated 1=24 PrePurgP 2=36 IgnitPos 3=44 Interv 1 4=52 Interv 2	0...4
R 03/04 W 06/16	41/29h	1	Modbus mode: Preselected output local / preselected output remote (default setting: 0)	R/W	U16	0 = Local 1 = Remote	0...1
R 03/04 W 06/16	42/2Ah	1	Modbus breakdown time: Max. time with no communication. When this time has elapsed, automatic change from Remote to Local will take place	R/W* EEPROM	U16		0...7200 s 0 = inactive
R 03/04 W 06/16	43/2Bh	1	Operating mode in Remote operation: Auto, Remote ON, Remote OFF (default setting: 0)	R/W	U16	0 = Auto 1 = ON 2 = OFF	0...2
R 03/04 W 06/16	45/2Dh	1	Preselected target output modulating / multistage	R/W	U16	Fire rate	Modulating: 0...100% Multistage: 1001...1003 Invalid: 32767
R 03/04 W 06/16	56/38h	2	Hours run fuel 0 resettable	R/W* EEPROM	S32		0...999999 h
R 03/04 W 06/16	58/3Ah	2	Hours run fuel 1 resettable	R/W* EEPROM	S32		0...999999 h
R 03/04	68/44h	2	Hours run unit live	R	S32		0...999999 h
R 03/04 W 06/16	70/46h	2	Start counter fuel 0 resettable	R/W* EEPROM	S32		0...999999
R 03/04 W 06/16	72/48h	2	Start counter fuel 1 resettable	R/W* EEPROM	S32		0...999999
03/04	76/4Ch	2	Start counter total (read only)	R	S32		0...999999
03/04	78/4Eh	2	Fuel volume fuel 0 0 = resettable	R/W* EEPROM	U32		0..99999999 m ³
03/04	80/50h	2	Fuel volume fuel 1 1 = resettable	R/W* EEPROM	U32		0..99999999 L
03/04	82/52h	1	Number of faults	R	U16		0...65535
R 03/04 W 06/16	84/54h	1	Preselected output in the event communication with BACS breaks down (fuel 0)	R/W* EEPROM	U16	Fire rate	Modulating: 0...100% Multistage: 1001...1003 Invalid: 32767

Function	Address dec/hex	Number of words	Data designation	Access	Data format	Data type / coding	Range
R 03/04 W 06/16	85/55h	1	Preselected output in the event communication with BACS breaks down (fuel 1)	R/W* EEPROM	U16	Fire rate	Modulating: 0...100% Multistage: 1001...1003 Invalid: 32767
03/04	98/62h	8	Burner control type reference (ASN)	R	U8[16]	String	
03/04	106/6Ah	1	Burner control parameter set code	R	U16		
03/04	107/6Bh	1	Burner control parameter set version	R	U16		
03/04	108/6Ch	3	Burner control identification date	R	U16[3]	Data	
03/04	111/6Fh	1	Burner control identification number	R	U16		
03/04	113/71h	1	Software version burner control	R	U16	Hexadecimal	
03/04	115/73h	8	Burner identification	R	U8[16]	String	
03/04	123/7Bh	1	Minimum output fuel 0	R	U16	Fire rate limit	20...100% 1001...1003 Invalid: 32767
03/04	124/7Ch	1	Maximum output fuel 0	R	U16	Fire rate limit	20...100% 1001...1003 Invalid: 32767
03/04	125/7Dh	1	Minimum output fuel 1	R	U16	Fire rate limit	20...100% 1001...1003 Invalid: 32767
03/04	126/7Eh	1	Maximum output fuel 1	R	U16	Fire rate limit	20...100% 1001...1003 Invalid: 32767
03/04	127/7Fh	1	Operation mode of burner fuel 0	R	U16		1...27
03/04	128/80h	1	Operation mode of burner fuel 1	R	U16		1...27
03/04	129/81h	2	Switching cycles <i>Revert to pilot</i>	R	S32		0...9999999
03/04	140/8Ch	1	Operation mode of burner fuel 0	R	U16		1...29
03/04	141/8Dh	1	Operation mode of burner fuel 1	R	U16		1...29
03/04	142/8Eh	2	Switching cycles <i>Revert to pilot</i>	R	S32		0...9999999
03/04	144/90	1	Lower range limit trim function fuel 0	R	S16	Percent	0...-15%
03/04	145/91	1	Upper range limit trim function fuel 0	R	S16	Percent	0...25%
03/04	146/92	1	Lower range limit trim function fuel 1	R	S16	Percent	0...-15%
03/04	147/93	1	Upper range limit trim function fuel 1	R	S16	Percent	0...25%
03/04	148/94	1	Input value analog input trim function	R	S16	Percent	-15...+25%

03/04	149/95	1	Current trim correction	R	S16	Percent	-15...+25%
03/04	150/96	1	Absolute speed	R	U16		0...65535
03/04	151/97	1	Mains voltage (standardized)	R	U16		0...255
03/04	544/ 220h	8	Error history: Current error Structure: Error code Diagnostic code Error class Error phase Type of fuel Output Start counter total	R	U16 U16 U16 U16 U16 U16 U32		
03/04	552/ 228h	8	Error history: Current error -1	R	U16/U32 []		
:	:	:	:	:	:		
03/04	744/ 2E8h	8	Error history: Current error -24	R	U16/U32 []		

* These parameters must not be continually written since they are stored in EEPROM, which only permits a limited number of write accesses over its lifecycle (< 100,000).

Note: To avoid a conflict with the LMV5 Modbus parameters, we recommend using the following parameters when operating the LMV3 with the LMV5 at the same time:

- Parameter no. 140 instead of parameter no. 127
- Parameter no. 141 instead of parameter no. 128
- Parameter no. 142 instead of parameter no. 129

Legend to overview table

Access	R R / W	Read only value Read and write value
Data format	U8 U16 U32 S16	Character string 16 bit integer (not subject to sign) 32 bit integer (not subject to sign) 16 bit integer (subject to sign) Note: This data type is also used to mark invalid or non-existing values by using the value «-1».
	S32	32 bit integer (subject to sign) Note: This data type is also used to mark invalid or non-existing values by using the value «-1».
[]		Data array

Data types

Type	Physical range	Internal range	Resolution	Conversion internally / physically
Percent	0...100%	0...1000	0.1%	/ 10
Degrees	-50...150°	-500...1500	0.1°	/ 10
Fire rate limit	Modulating operation: 20...100% Multistage operation: 1001 = stage 1 1002 = stage 2 1003 = stage 3 32767 = invalid	Modulating operation: 200...1000 Multistage operation: 1001...1003 32767 = invalid	Modulating operation: 0.1% Multistage operation: 1	Modulating: / 10 Multistage: - 1000
Fire rate	Modulating operation: 0...100.0% Multistage operation: 1001 = stage 1 1002 = stage 2 1003 = stage 3 32767 = invalid	Modulating operation: 0...1000 Multistage operation: 1001...1003 32767 = invalid	Modulating operation: 0.1 % Multistage operation: 1	Modulating: / 10 Multistage: - 1000

Modbus Address / LMV3 Parameter Cross-Reference Guide

Modbus Address	Description	LMV3 Parameter
0	Burner control phase	961
1	Position of current fuel actuator	922:00
4	Position of air actuator	922:01
8	Manipulated variable VSD	936
9	Current type of fuel	945
10	Current output	903:00, 903:01
13	Flame signal	954
14	Current fuel throughput	960
21	Startup counter total	166
25	Current error: Error code	701:01, 981
26	Current error: Diagnostic code	701:02, 982
27	Current error: Error class	701:03
28	Current error: Error phase	701:04
35	Inputs	947:00
37	Outputs	947:01
38	Program stop	208
41	Modbus mode: local / remote	N/A
42	Modbus breakdown time	142
43	Modbus: operating mode in remote	N/A
45	Preselected target output	121
56	Hours run fuel 0 resettable	162
58	Hours run fuel 1 resettable	172
68	Hours run unit live	163
70	Startup counter fuel 0 resettable	164
72	Startup counter fuel 1 resettable	174
76	Startup counter total (not resettable)	166
78	Fuel volume fuel 0	167
80	Fuel volume fuel 1	177
82	Number of faults	161
84	Preselected output no comm. (fuel 0)	148
85	Preselected output no comm. (fuel 1)	149
98	Burner control type reference (ASN)	111
106	Burner control parameter set code	104
107	Burner control parameter set version	105
108	Burner control identification date	102
111	Burner control identification number	103
113	Software version burner control	107
115	Burner identification	113
123	Minimum output fuel 0	545
124	Maximum output fuel 0	546

Modbus Address	Description	LMV3 Parameter
125	Minimum output fuel 1	565
126	Maximum output fuel 1	566
127	Operation mode of burner fuel 0	201
128	Operation mode of burner fuel 1	301
129	Switching cycles <i>Revert to pilot</i>	176
140	Operation mode of burner fuel 0	201
141	Operation mode of burner fuel 1	301
142	Switching cycles <i>Revert to pilot</i>	176
144	Lower range limit trim function fuel 0	547
145	Upper range limit trim function fuel 0	567
146	Lower range limit trim function fuel 1	548
147	Upper range limit trim function fuel 1	568
148	Input value analog input trim function	916
149	Current trim correction	918
150	Absolute speed	935
151	Mains voltage (standardized)	951
544-743	Fault history	701-725

Changeover of controller operating mode

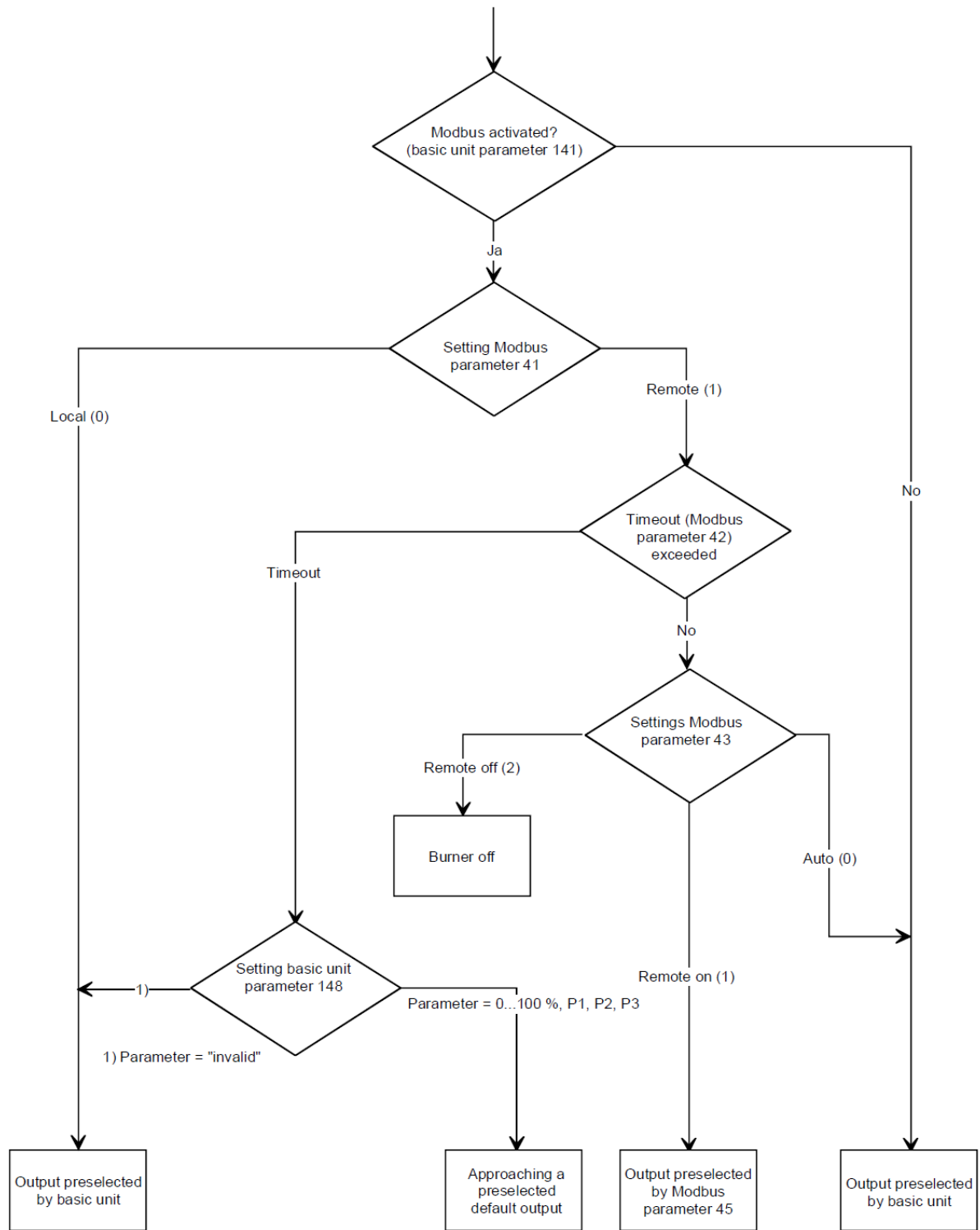

7541d44e/0407

Operating Modes

Changing between «local» and «remote» mode After activating Modbus communication, data can be exchanged between the LMV3 and the Modbus master via the Modbus interface. Preselection of the target output via Modbus can only be made after the Modbus mode has been switched from «local» to «remote». This change is made by writing to Modbus address 41.

The preselection of the target output that was made previously has no impact and is set «invalid» when changing to remote operation.

The presetting after activation of Modbus communication is «local». When the LMV3 is switched off, the mode is set back to the presetting.

Changeover of Modbus operating mode between «auto», «remote on», and «remote off» This setting is used to determine the behavior of the system in remote operation. The setting is made by writing to Modbus address 43. With the «auto» setting, the output to be delivered is determined by the LMV3. With the «remote on» setting, the Modbus master determines the output to be delivered by the system by predefining a target output. With the «remote off» setting, the burner will be shut down. A new start is made only when the operating mode changes to «remote on» and a new preselection of target output is made, or after a change to local operation. For output preselection via the building automation and control system, the controller on contact on the LMV3 must be closed. The presetting after activation of remote operation is «auto». When the LMV3 is switched off, the operating mode will be reset to the preselected mode.

Monitoring of Modbus timeout If communication between the Modbus and the LMV3 is interrupted, the length of time that the interruption lasts will be monitored. Every permissible Modbus communication on the LMV3 will restart monitoring. Monitoring only takes place in «remote» operation. If the time parameterized for communication timeout (Modbus address 42) is exceeded, a change from remote to local operation will take place. In that case, the system travels to the parameterized preselected output to be delivered in the event of a communication breakdown (Modbus address 84/85).



If the time is exceeded, remote operation must be selected again by the Modbus master. Upon a return of communication, addresses 41 and 43 and the preselected output must be written again. Only then can the output be readjusted. Timeout is a Modbus parameter and is retained even if the LMV3 is switched off.

Bus behavior in the event of burner lockout

If the LMV3 has triggered a lockout due to a fault, the selected operating mode with remote mode (Modbus addresses 41 and 43) will be retained when the unit is reset. For the required target output to be reached, all that is required is to preselect the output again via Modbus address 45.

Modbus settings on the LMV3

To be able to edit the Modbus parameters on the LMV3, at least the service level password must be entered via the AZL2... / ACS410.

Slave address

Setting the slave address is made via parameter 145. Any address from 1...247 can be used. The slave address is stored in nonvolatile memory in the LMV3. Changes to parameter 145 can only be made via the LMV3..., not via Modbus.

Parameter	Default	Range	Description
145	1	1-247	Sets the LMV3 address for Modbus.

Baud rate of Modbus interface

Setting the Baud rate is made via parameter 146. This parameter specifies the transmission rate for the Modbus interface. The Baud rate is stored in nonvolatile memory in the LMV3. Changes to parameter 146 can only be made via the LMV3..., not via Modbus.

Parameter	Default	Range	Description
146	1	0-1	Sets the baud rate of the Modbus port X92: 0 = 9600 bit/s 1 = 19200 bit/s

Parity of Modbus interface

Setting the parity is made via parameter 147. The parity is stored in nonvolatile memory in the LMV3. Changes to parameter 147 can only be made via the LMV3..., not via Modbus.

Parameter	Default	Range	Description
147	0	0-2	Sets the parity of the Modbus port X92: 0 = none 1 = odd 2 = even

Timeout in the event of communication breakdown

Setting the timeout for communication loss between Modbus and the LMV3 is made via parameter 142. When this time has elapsed, the Modbus operating mode changes automatically from «remote» to «local» and the output specified by parameter 148/149 will be delivered. The timeout is stored in nonvolatile memory in the LMV3. Changes to parameter 142 can be made via the LMV3... and via Modbus.

Parameter	Default	Range	Description
142	120 sec	0-7200 sec	If no communication occurs for this period of time, the LMV3 considers the Modbus to be unavailable and will look for a fire rate command from another source. A setting of 0 makes the timeout inactive and the LMV3 will wait for the Modbus communication to be available again. 0 = none 1 = odd 2 = even

Preselected output in the event of communication breakdown

Setting the fire rate when Modbus communication is interrupted is made via parameter 148 (fuel 0) and 149 (fuel 1). The output set with this parameter is approached when, in remote operation, communication is interrupted for longer than the period of time set by parameter 142. If this output is set «invalid» and communication is interrupted, the system will deliver the output set on the LMV3. The fire rate is stored in nonvolatile memory in the LMV3. Changes to parameter 148/149 can be made via the LMV3... and via Modbus.

Parameter	Default	Range	Description
148/149	Not set	0-100%	This sets the fire rate when Modbus communication is interrupted. A setting from 20-100% will set the output of the burner. A setting of 0-19.9% will shut down the burner.

Activation of Modbus

Setting the Modbus operating mode is made via parameter 141. Modbus functionality on the LMV3 will be activated when setting this parameter to 1. The operating mode is stored in nonvolatile memory in the LMV3. Changes to parameter 141 can only be made via the LMV3..., not via Modbus.

Parameter	Default	Range	Description
141	0	0-2	Sets the Modbus operating mode: 0 = off (inactive) 1 = on (active) 2 = not used

Modbus in connection with ACS410 / AZL2...

If the ACS410 PC tool is being used while writing to the LMV3 via Modbus, it must be taken into consideration that write access via Modbus will be rejected if, at the same time, the ACS410 also makes a write access to parameters. Also, the simultaneous setting of a parameter from the AZL2... and the Modbus master must be avoided, since it would not be possible to predict who is granted the access right. Write access via Modbus is possible at any time, independent of the AZL2... or ACS410 PC tool.

Error Handling

In the event of erroneous telegrams (CRC errors, etc.), the AZL2... does not send an exception code (refer to Modbus definition), but ignores the messages. This is because commercially available Modbus drivers do not normally respond to exception codes.

Intentionally Left Blank

Section 1	Overview
Section 2	Wiring
Section 3	Parameters
Section 4	Commissioning
Section 5	VSD
Section 6	Troubleshooting
Section 7	Modbus
Section 8	ACS410
Appendix A	Application Guide

Section 1	Overview
Section 2	Wiring
Section 3	Parameters
Section 4	Commissioning
Section 5	VSD
Section 6	Troubleshooting
Section 7	Modbus
Section 8	ACS410
Appendix A	Application Guide

Section 8-1: ACS410 Software Introduction

The LMV3 system can be completely programmed using either the AZL23 or a PC with the ACS410 software. Most people find that using the AZL23 is more convenient than the ACS410 for a “manual” setup of the LMV3 parameters. However, the ACS410 has additional capabilities that are not available with the AZL23 / LMV3 alone. These additional, valuable capabilities are:

1. Saving and printing all LMV3 settings, combustion curves, and information in a report format. This provides a convenient, comprehensive startup report.
2. Saving and uploading entire LMV3 parameter sets to or from a PC.
3. Viewing and saving trends.
4. Viewing a status screen of the LMV3 inputs and outputs as well as the LMV3 operating state.
5. Setting and visualization of fuel-air ratio curves

The following pages will cover the software installation and how to connect the LMV3 to a PC, as well as explain how to utilize the basic capabilities of the ACS410 software, including parameter sets, startup reports, trending, and the status screen.

Since most people prefer to use the AZL23 to set parameters and combustions curves in the LMV3, the procedure to do this with ACS410 will not be covered in this guide. For technical information about how to program the LMV3 through the ACS410 software, email techsupport@scccombustion.com or go to www.scccombustion.com/lmv3.htm and click on “ACS410 Software Operating Instructions”.

The ACS410 software can be used with the following PC operating systems:

- Windows XP (service pack 2 minimum)
- Windows 7
- Windows 8.1
- Windows 10

ACS410 cannot be used with the following PC operating systems:

- Windows Vista
- Windows ME

Section 8-2: Software Installation

The following steps outline the procedure for installing the ACS410 software on a PC.

1. The ACS410 software can be downloaded from the SCC website:
 - a. Go to *www.scccombustion.com/lmv3.htm*.
 - b. Click on “ACS410 Software (21MB)” towards the bottom to begin the download.

2. Once the ACS410 software has been downloaded, double-click on the setup.exe file. This should start the installation. Pick the desired options as the installation prompts:
 - a. Select the installation language and click “OK”.
 - b. When prompted, click “Next”.
 - c. Accept the license agreement and click “Next”.
 - d. Select the folder where the ACS410 software will be installed. The default folder is *C:\Program Files (x86)\Siemens\ACS410*. Click “Next”.
 - e. Select the folder where the ACS410 software shortcuts will be installed in the Start Menu. The default folder is *ACS410*. Click “Next”.
 - f. Select the checkbox if an ACS410 desktop icon is desired. Click “Next”.
 - g. Review the installation choices. If everything looks correct, click “Install”.
 - h. The ACS410 software will now be installed on the PC.

3. Once the ACS410 software installation is complete, a prompt to install the OCI410 device drivers will appear. Perform the following steps to install these drivers:
 - a. Click “Next”.
 - b. The OCI410 drivers will now be installed.
 - c. Once the OCI410 drivers have been installed successfully, click “Finish”.
 - d. Select the checkbox if it is desired for ACS410 to launch immediately, then click “Finish”.

4. At this point, the ACS410 software is ready to run.

Section 8-3: Connecting to a PC

The following steps summarize the procedure for establishing communication between the LMV3 and a PC.

1. An OCI410 interface module is required to connect the LMV3 to a PC. Three different interface modules are available:

Table 9-1: Available Interface Modules to Connect the LMV3 to a PC

Interface Module	Capabilities
OCI410.20	User level PC interface module. Permits access to user level parameters only without the ability to perform parameter backups
OCI410.30	Service level PC interface module. Permits access to user and service level parameters and the ability to perform parameter backups
OCI410.40	OEM level PC interface module. Permits access to all parameters and the ability to perform parameter backups

It is highly recommended to acquire at least the OCI410.30 interface module.

2. Once the interface module is acquired, the LMV3 can be connected to the PC. Unplug the AZL23 from the LMV3. Connect the RJ11 plug of the OCI410 interface module into the BCI port on the LMV3. Connect the USB plug of the OCI410 interface module into a USB port on the PC. The ACS410 software should automatically identify which COM port the OCI410 interface module is plugged into.

3. Open the ACS410 software. Click “OK” on the safety note and the “Login” dialog box will appear. Click the “Online” button, and then select which password level is desired (IS – user, SO – service, OEM – OEM). If attempting to connect at the service or OEM level, enter the password. Remember that the OCI410.30 module is required to access the service level, and the OCI410.40 module is required to access the OEM level. Then click “Connect”.

Note: The password is case-sensitive, and only certain characters are allowed to be typed into the password field. For this reason, it is much easier to click the “#” button next to the password and click on each character instead of typing the password manually.

Section 8-4: Saving a Parameter Set to a PC

The following steps outline the procedure for saving parameter sets to a PC.

1. Ensure that the ACS410 software is open, and the PC is connected to the LMV3 at the service or OEM level. See previous sections if necessary. The LMV3 must have a burner ID in order to perform a parameter backup. The burner ID is set via parameter 113.
2. Click on the “Backup / Restore” tab. Click on “Backup” in the lower right corner.
3. A box will appear called “Backup description”. The default file name is the current date and time. It is highly recommended to change the file name to something more job-specific. Additionally, information can be added for description, device number, burner type, and burner serial number. Once all of the relevant information has been entered, click “OK”.
4. After about a minute, a box should appear stating that the backup was successful and the backup file should now be listed on the screen. The default location for storing parameter sets is *C:\Program Files (x86)\Siemens\ACS410\bkp*. Notice that two files are created in this folder: one with a .bkp file extension and one with a .unl file extension. Both files are necessary in order to view the parameter set or restore it to an LMV3.

Note: The parameter set is stored in machine language, so it is not useful as a startup report. See the following section called “Creating an LMV3 Startup Report” for the procedure for creating and printing a comprehensive startup report.

Section 8-5: Uploading a Parameter Set to an LMV3

The following steps outline the procedure for uploading parameter sets from a PC to an LMV3.

1. Ensure that the ACS410 software is open, and the PC is connected to the LMV3 at the service or OEM level. See previous sections if necessary.
2. Click on the “Backup / Restore” tab. A list of stored parameter sets will display on the screen. Select the parameter set to be uploaded into the LMV3 and click on “Restore” in the lower right corner. **This file will overwrite the parameter set on the LMV3 and will determine the behavior of the LMV3. Be sure that the correct file is selected.**
3. A prompt will appear asking to confirm that the proper file was selected. Click “Yes”. After about a minute, a box should appear stating that the upload was successful. If an error message is returned, see below for the cause of the error:

Burner ID: The burner ID of the data set stored on the PC does not match the burner ID of the LMV3. View the burner ID (parameter 113) of the stored parameter set and ensure that it matches the burner ID displayed by parameter 113 on the LMV3.

Incompatible parameter sets: The current software version of the LMV3 is not compatible with the software version of the parameter set stored on the PC.

Different types of units: It is not possible to copy the parameter set from an LMV36 to an LMV37, and vice versa.

Section 8-6: Creating an LMV3 Startup Report

The following steps outline the procedure for saving, viewing, and printing a startup report to a PC.

1. Open the ACS410 software. Instead of logging in, click the “Offline” button. Then click the “Backup” button and press “OK”. The ACS410 is now in offline mode and not communicating with the LMV3.
2. The screen should list all of the parameter backups that have previously been made. If a new parameter backup needs to be made before creating the startup report, see the previous section called “Saving a Parameter Set to a PC”.
3. Select the parameter set to be used for creating the startup report. Then click on “Load” in the lower right corner.
4. The “Info / Service” tab will now display all of the user level parameters and the fault history of the selected parameter set. The “Parameters” tab will display all of the service and OEM level parameters of the selected parameter set.
5. Select the “File” dropdown menu, and click on “Report”. Enter a description of the parameter set if desired, then click on “OK” to generate the startup report.
6. A print preview of the startup report will be displayed. The startup report displays every parameter setting, the fault history, and the fuel-air ratio curves.
7. To print the startup report, click “Print”. The startup report can also be saved in PDF format by printing it to a PDF writer. Most people prefer to have a PDF file of the parameter list, fault history, and fuel-air ratio curves. These pieces provide a very inclusive LMV3 startup report.

Section 8-7: Saving and Viewing Trends

The ACS410 software can be used to view and save trends. Trending enables a technician to easily view and quantify system behavior over time. The following steps outline the procedure for viewing and saving trends with the ACS410 software.

1. Open the ACS410 software and connect at the desired access level. For example, when logged in at the user level, only user level parameters can be trended. See previous sections if necessary. Most parameters that are desirable to trend are user level parameters (900 series parameters). After the connection is established, click on the “Trending” tab. An example of the trending screen is shown below in Figure 8-1.

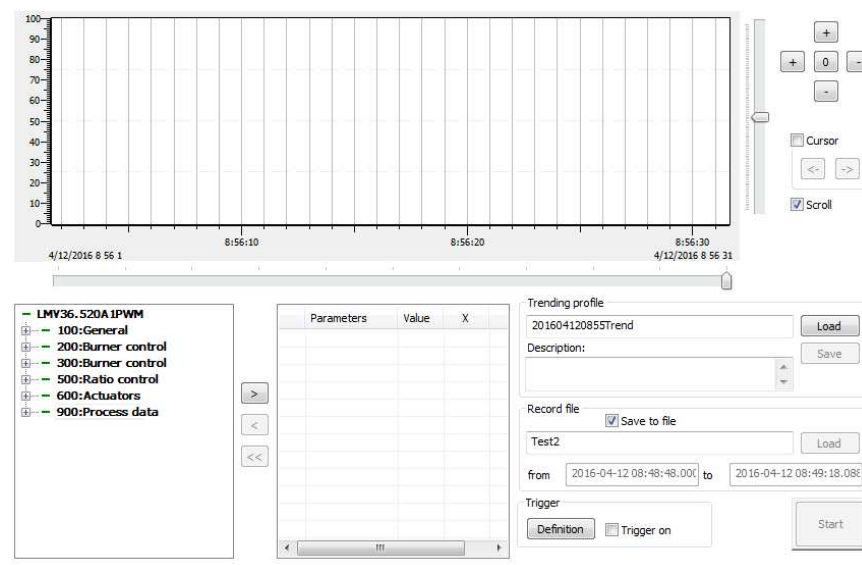

Figure 8-1: The ACS410 Trending Screen

2. All of the parameters available to be trended are listed in the lower left corner. Double-click on any parameter or use the “>” button to select it as a parameter to be trended. A maximum of 9 parameters can be trended at one time.
3. Use the “X” column to select a multiplier other than 1. Click on the color square next to the “X” column to change the color of the trend.
4. Once all of the trend settings (trending profile) have been set, these settings can be saved if desired. To save the trending profile, enter a file name in the “Trending profile” text box. The default name is the current date and time. Add a description if desired, and then click “Save”. Trending profiles are stored at: *C:\Program Files\ (x86) \Siemens\ACS410\tn*. All trending profiles are saved as .ptd files. Once the trending profile has been saved, a dialog box will appear stating the save was successful. Click “OK”.

-
5. Before starting the trend, click on the “Save to file” check box if the trending data is to be stored to a file. Enter a file name in the provided text box. The default name is the current date and time.

 6. Click the “Start” button to start the trending. Use the “+” and “-” buttons to adjust the scale of the trend, or click the “0” button to return to the initial scale. Check the “Cursor” check box to add a double line showing the cursor and to open a pop-up window showing the exact values of the selected parameters. When the “Cursor” button is checked, the “<-” and “->” buttons can be used to change the cursor’s position and update the values in the pop-up window accordingly.

 7. The trend will be buffered until the “Stop” button is clicked. The trending data will now be saved under the file name created in step 5. Trending data is stored in the following location: *C:\Program Files (x86)\Siemens\ACS410\tn*. Each set of trending data creates two files: one with a .unl format and one with a .dtd format. Both files are necessary if the trend is to be viewed at a later time through the ACS410 software.

 8. To view a previously saved trend through the ACS410 software, click “Login” at the top of the screen. Click the “Offline” button, then the “Trending” button, and then click “OK”. A list of the saved trending data sets will appear. Choose the trending data that is to be viewed and click “Load”.

 9. To open previously saved trending data in Microsoft Excel, first open Microsoft Excel. Click on “File” and then click “Open”. Navigate to the *C:\Program Files (x86)\Siemens\ACS410\tn* folder, and open the .dtd file corresponding to the trending data to be opened. If the .dtd file does not appear, select “All Files” in the dropdown menu in the lower right corner to ensure all file types are displayed. Once the .dtd file is opened, the trending data will be displayed in a clear, readable format.

Section 8-8: Viewing the Status Screen

When connected to the LMV3, the ACS410 can provide a status screen. This provides a useful summary of the LMV3 inputs and outputs, as well as the operating state of the LMV3. The following steps outline the procedure for viewing the ACS410 status screen.

1. Open the ACS410 software, and connect to the LMV3 at any password level.
2. Once connected, click on the “Status” tab at the top of the screen. The status screen will appear detailing the operating state of the LMV3. The status screen looks like Figure 8-2 below.

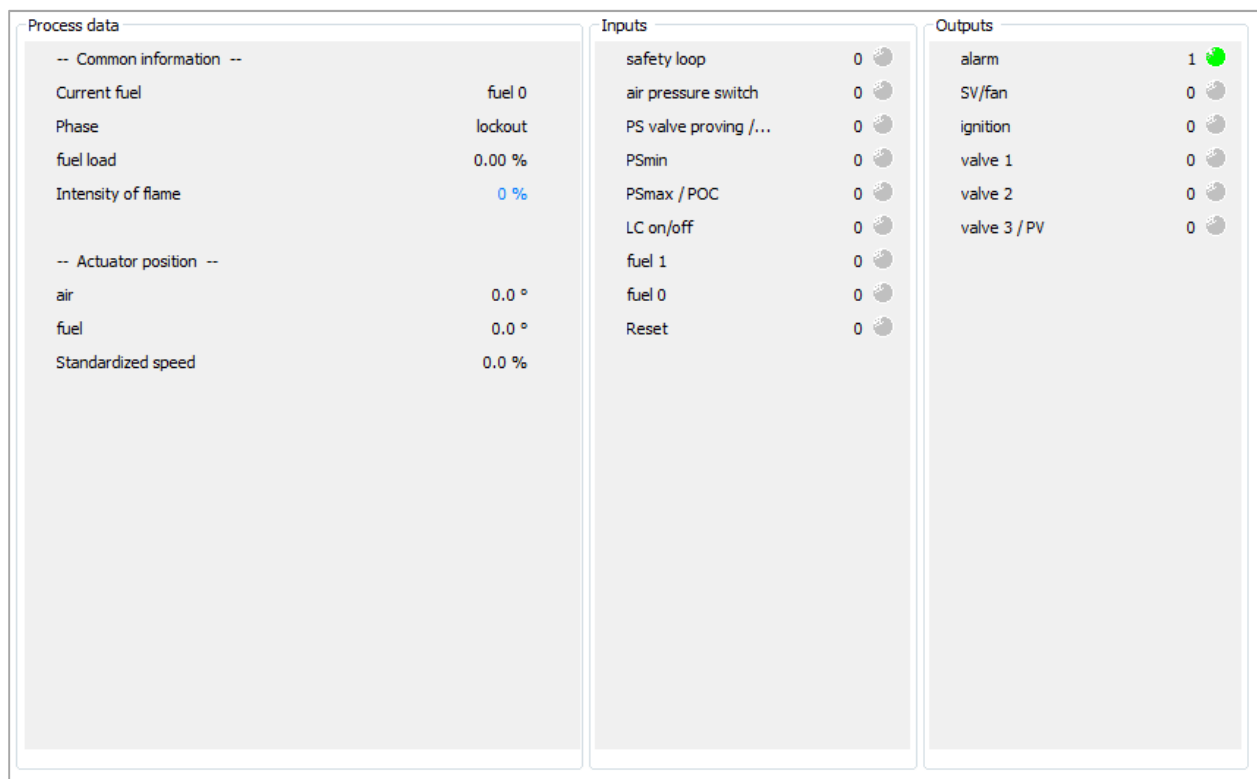

Figure 8-2: The ACS410 Status Screen

Intentionally Left Blank

Section 1	Overview
Section 2	Wiring
Section 3	Parameters
Section 4	Commissioning
Section 5	VSD
Section 6	Troubleshooting
Section 7	Modbus
Section 8	ACS410
Appendix A	Application Guide

Section 1	Overview
Section 2	Wiring
Section 3	Parameters
Section 4	Commissioning
Section 5	VSD
Section 6	Troubleshooting
Section 7	Modbus
Section 8	ACS410
Appendix A	Application Guide

Appendix A: LMV3 Application Guide

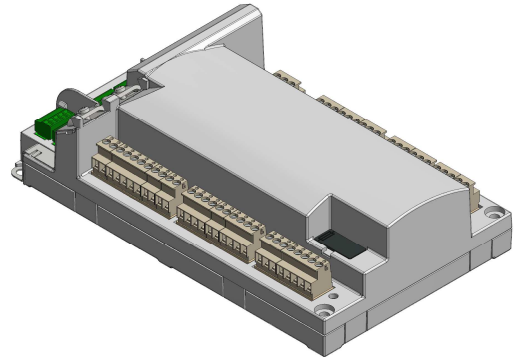

Description

The LMV3 Application Guide includes programming, wiring, and operation examples of the control system for the most common applications.

Table of Contents

Fresh Air Damper

Introduction.....	4
Procedure	4
Operation	5
Important Notes	5

Hot Standby on a Steam Boiler with an RWF55

Introduction.....	6
Procedure	6
Operation	7
Important Notes	7

Low Fire Hold with an RWF55

Introduction.....	8
Procedure - Steam Boiler with an RWF55 with Analog Output	9
Procedure - Hot Water Boiler with an RWF55 with Analog Output.....	10
Procedure - Steam Boiler with an RWF55 with 3-position Output (LMV37 only)	11
Procedure - Hot Water Boiler with an RWF55 with 3-position Output (LMV37 only)	12
Operation	13
Example	13

Pilot Valve Proving

Introduction.....	14
Procedure	14
Option 1: On Startup with SKP25's on both the Pilot and Main Gas Trains	16
Sequence of Operation	17
Important Notes	17
Option 2: On Startup, SKP25 on the Main Gas Train, Solenoid Valves on the Pilot Train	18
Sequence of Operation	19
Important Notes	19
Option 3: Pilot Valve Proving on Startup and Main Valve Proving on Shutdown	20
Sequence of Operation	21
Important Notes	21

Table of Contents (continued)

Purge Proving

Introduction.....	22
Procedure	22
Operation	23

Revert to Pilot - LMV37 only

Introduction.....	24
Procedure	24
Sequence of Operation	25
Operation Example	27
Important Notes	28

Stack Damper

Introduction.....	29
Procedure	29
Operation	30
Important Notes	30

Fresh Air Damper

Introduction

In some applications, a fresh air damper is used to bring air into the boiler room during operation. Typically, it is desired to have the fresh air damper fully open before the combustion fan turns on, and to leave the damper open until the combustion fan turns off again. The following procedure will describe how to wire a fresh air damper to the LMV3 so that the damper is open anytime the combustion fan is on.

Procedure

1. Wire the LMV3, RWF5x load controller, and fresh air damper as shown in Figure 1.

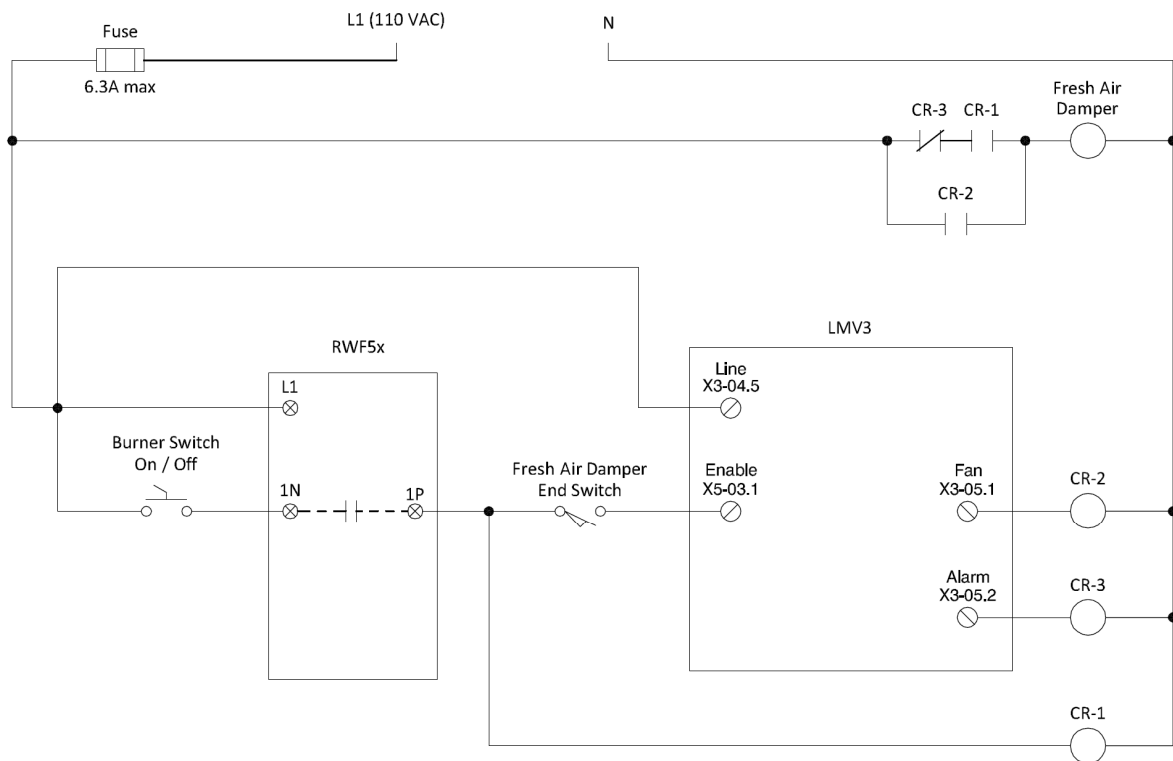

Figure 1: LMV3 Fresh Air Damper Wiring

Fresh Air Damper (continued)

Operation

1. When there is no call for heat from the RWF5x load controller, the internal contact between terminals 1N and 1P will be open. Both CR-1 and CR-2 coils will be de-energized, and the fresh air damper will be closed.
2. When the RWF5x load controller receives a call for heat, the internal contact between terminals 1N and 1P will close. Terminal 1P will be energized as long as the burner on / off switch is on. Coil CR-1 will be energized, closing the CR-1 contact. As long as the LMV3 is not in alarm (CR-3 contact is closed), the fresh air damper will begin driving open.
3. Once the fresh air damper drives fully open, the fresh air damper end switch will close, and the burner will turn on.
4. The fresh air damper will remain open until the fan turns off. Once the fan turns off, contact CR-2 will open and un-latch the circuit.

Important Notes

1. The described procedure cannot be used with continuous fan.
2. The burner startup cycle will be lengthened by the stroke time of the fresh air damper actuator.

Hot Standby on a Steam Boiler with an RWF55

Introduction

Hot standby is recommended on multi-boiler systems to maintain one or more backup boilers close to operating temperature. Hot standby can be accomplished on an LMV3 with an RWF55 controller. The RWF55 has two functions:

- Control the load of the boiler based on steam pressure
- Control the hot standby based on shell temperature

The procedure and operation for using the RWF55 for both load control and hot standby is described below.

Procedure

1. Wire the RWF55 to the LMV3 as shown in Figure 2.

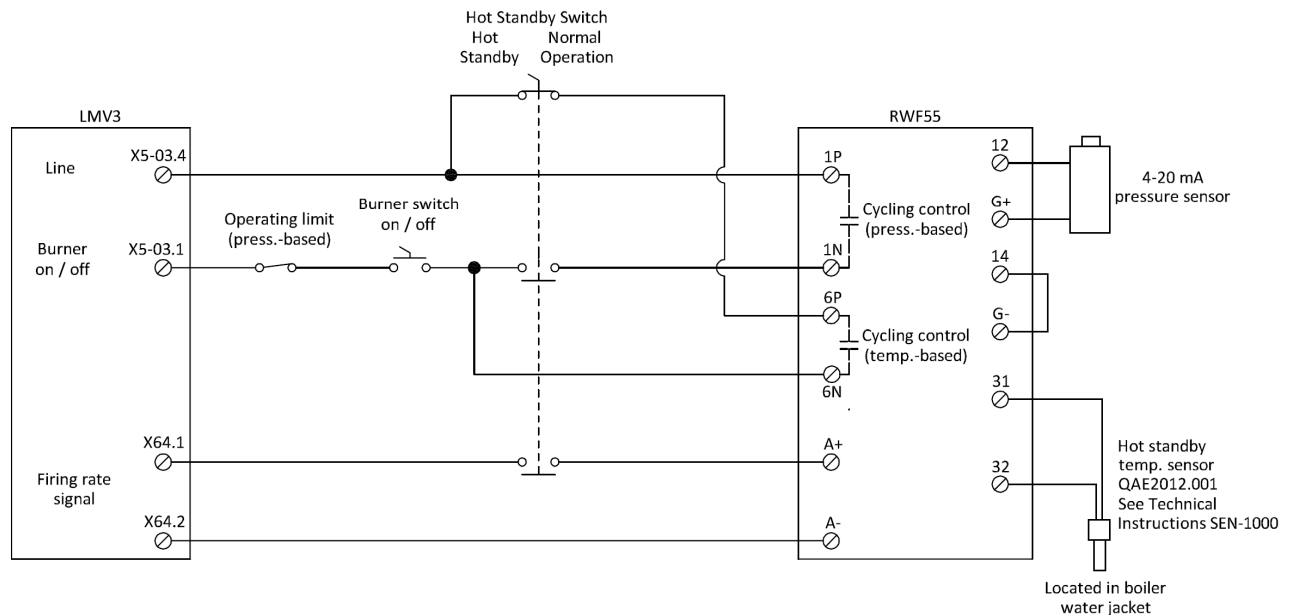

Figure 2: LMV3 Hot Standby Wiring

2. On an LMV37 only: Place a jumper between terminals X5-03.2 and X5-03.4.
 On an LMV36 only: Set parameter 204 to 2. If 2 is not an option (older LMV36s), set parameter 204 to 0.
 These steps will ensure that when the boiler turns on in hot standby mode, it will always operate at low fire.

Hot Standby on a Steam Boiler with an RWF55 (continued)

3. Set the following parameters in the RWF55 controller. For more information, obtain Siemens Document No. U7867 for the RWF55 at www.scccombustion.com.

ConF > Cntr > CtYP = 2
ConF > Cntr > SPL = setpoint range lower limit
ConF > Cntr > SPH = setpoint range upper limit
OPr > SP1 = normal operation setpoint
PArA > HYS1 = burner on for normal operation (pressure-based)
PArA > HYS3 = burner off for normal operation (pressure-based)
ConF > InP > InP1 > SEn1 = pressure sensor type
ConF > InP > InP1 > SCL1 = 0
ConF > InP > InP1 > SCH1 = high end of the range of the pressure sensor
ConF > InP > InP3 > SEn3 = temperature sensor type
ConF > Inp > Inp3 > dF3 = 0
ConF > AF > FnCt = 12
ConF > AF > AL = hot standby setpoint (temperature-based)
ConF > AF > HYSt = burner on / off for hot standby (temperature-based)
ConF > OutP > SiGn = 1

Operation

1. When the hot standby switch is set for hot standby, the LMV3 system is in hot standby mode. The burner will turn on and off based on the temperature limits set in the RWF55 controller for hot standby (ConF > AF). Since the signal to LMV3 terminal X64.1 is broken by the hot standby switch, the LMV3 stays at low fire until the burner turns off based on the burner off point set in the RWF55.
2. When the hot standby switch is set for normal operation, the system is in normal operation mode and not in hot standby. The burner will turn on and off based on the pressure limits set in the RWF55 controller for normal operation (PArA > HYS1 and PArA > HYS3). The signal to LMV3 terminal X64.1 determines the firing rate of the burner.

Important Notes

1. An RWF55 controller must be used (not RWF50).
2. The RWF55 is operating as the load controller during normal operation as well as controlling the hot standby.

Low Fire Hold with an RWF55

Introduction

Low fire hold assists in preventing boiler damage from thermal shock. If an RWF55 is the load controller with the LMV3, a low fire hold can be easily incorporated. With an RWF55, a low fire hold is accomplished by breaking the increase load signal to the LMV3. The wiring and setup for four cases will be described:

- Steam boiler with an RWF55 with analog output
- Hot water boiler with an RWF55 with analog output
- Steam boiler with an RWF55 with 3-position output (LMV37 only)
- Hot water boiler with an RWF55 with 3-position output (LMV37 only)

The wiring and setup of the RWF55 differs slightly depending on the mode selected as shown on the following pages.

Low Fire Hold with an RWF55 (continued)

Procedure – Steam Boiler with an RWF55 with Analog Output

In the case of steam boilers, temperature sensors located in the boiler water jacket are recommended. Technical Instructions SEN-1000 provides additional information on temperature sensors.

1. Do the following:

On an LMV37 only: Place a jumper between terminals X5-03.2 and X5-03.4.

On an LMV36 only: Set parameter 204 to 2. If 2 is not an option (older LMV36s), set parameter 204 to 0.

2. Set the following parameters in the RWF55:

ConF > Inp > Inp1 > SEN1 = signal type of pressure sensor

ConF > Inp > Inp1 > SCL1 = 0

ConF > Inp > Inp1 > SCH1 = high end of the range of the pressure sensor

ConF > Inp > Inp3 > SEN3 = type of RTD being used for a belly sensor

ConF > Inp > Inp3 > dF3 = 0

ConF > Cntr > CtYP = 2

ConF > AF > FnCt = 11

ConF > AF > AL = temperature to enable low fire hold

ConF > AF > HYSt = deadband around low fire hold temperature

ConF > OutP > FnCt = 4

ConF > OutP > SiGn = 1

3. Wire the LMV3 and RWF55 as shown in Figure 3:

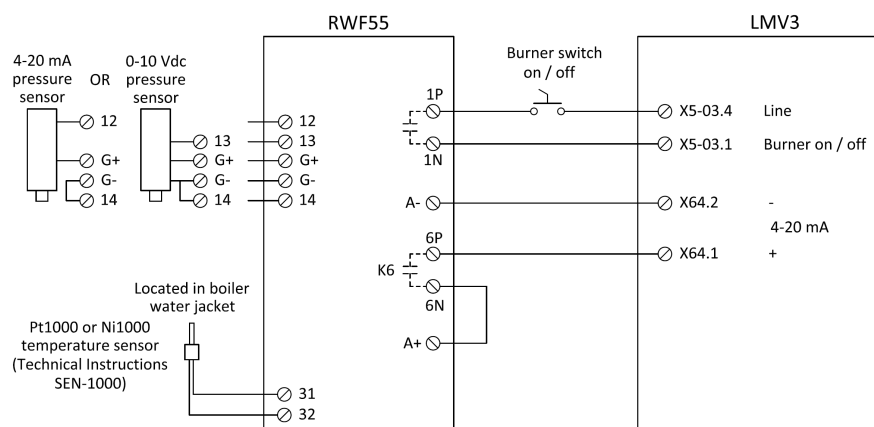

Figure 3: Low Fire Hold via Analog Output on a Steam Boiler

See page 19 for an example of the low fire hold operation.

Low Fire Hold with an RWF55 (continued)

Procedure – Hot Water Boiler with an RWF55 with Analog Output

1. Do the following:

On an LMV37 only: Place a jumper between terminals X5-03.2 and X5-03.4.
On an LMV36 only: Set parameter 204 to 2. If 2 is not an option (older LMV36s), set parameter 204 to 0.

1. Set the following parameters in the RWF55:

ConF > Inp > Inp1 > SEN1 = type of RTD being used for temperature sensor
ConF > Cntr > CtYP = 2
ConF > AF > FnCt = 7
ConF > AF > AL = temperature to enable low fire hold
ConF > AF > HYSt = deadband around low fire hold temperature
ConF > OutP > FnCt = 4
ConF > OutP > SiGn = 1

2. Wire the LMV3 and RWF55 as shown in Figure 4:

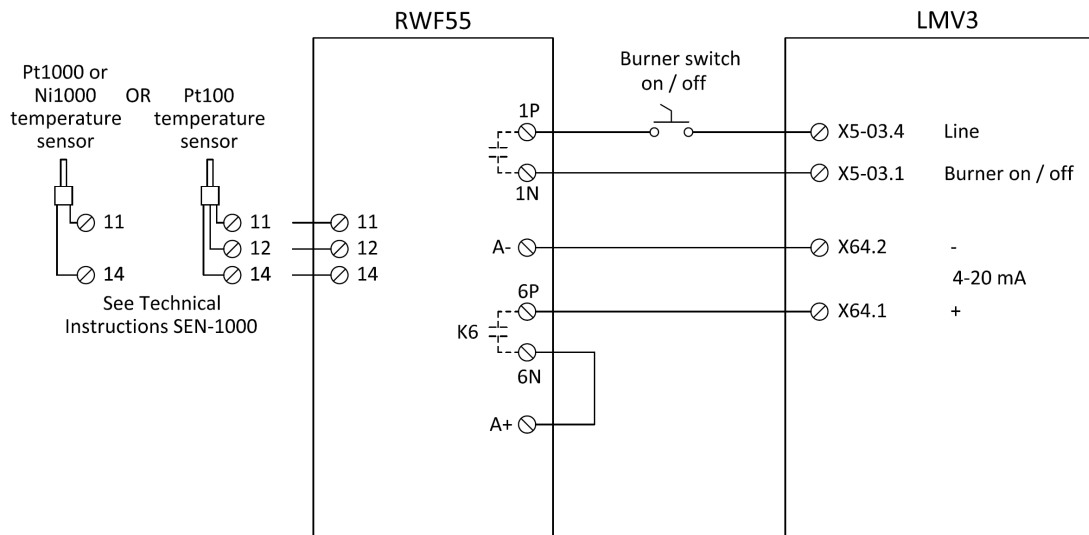

Figure 4: Low Fire Hold via Analog Output on a Hot Water Boiler

See page 19 for an example of the low fire hold operation.

Low Fire Hold with an RWF55 (continued)

Procedure – Steam Boiler with an RWF55 with 3-position Output (LMV37 only)

In the case of steam boilers, temperature sensors located in the boiler water jacket are recommended. Technical Instructions SEN-1000 provides additional information on temperature sensors.

1. Set the following parameters in the RWF55:

ConF > Inp > Inp1 > SEN1 = signal type of pressure sensor being used
 ConF > Inp > Inp1 > SCL1 = 0
 ConF > Inp > Inp1 > SCH1 = high end of the range of the pressure sensor
 ConF > Inp > Inp3 > SEN3 = type of RTD being used for a belly sensor
 ConF > Inp > Inp3 > dF3 = 0
 ConF > Cntr > CtYP = 1
 ConF > AF > FnCt = 11
 ConF > AF > AL = temperature to enable low fire hold
 ConF > AF > HYSt = deadband around low fire hold temperature

2. Wire the LMV37 and RWF55 as shown in Figure 5:

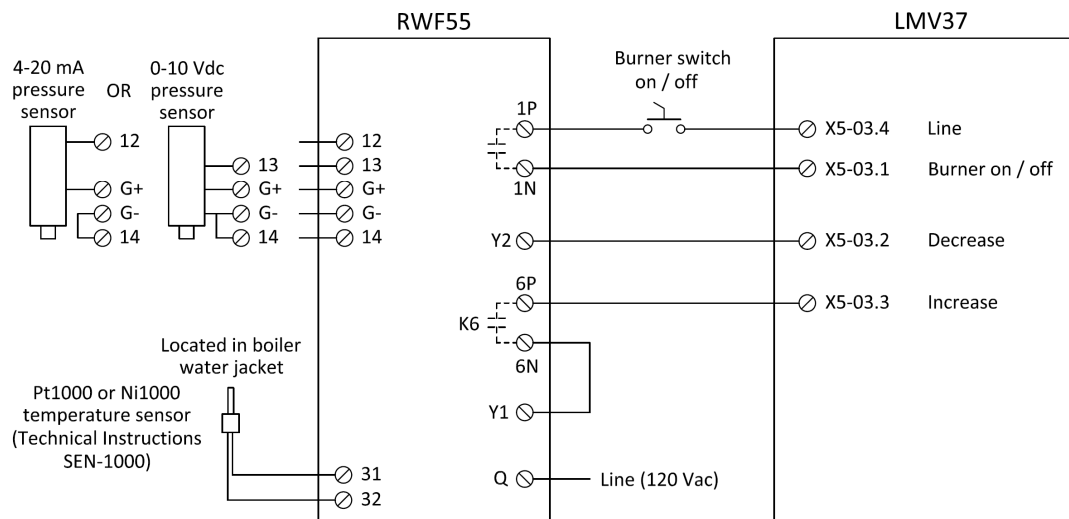

Figure 5: Low Fire Hold via 3-position Output on a Steam Boiler

See page 19 for an example of the low fire hold operation.

Low Fire Hold with an RWF55 (continued)

Procedure – Hot Water Boiler with an RWF55 with 3-position Output (LMV37 only)

1. Set the following parameters in the RWF55:

ConF > Inp > Inp1 > SEn1 = type of RTD being used for temperature sensor

ConF > Cntr > CtYP = 1

ConF > AF > FnCt = 7

ConF > AF > AL = temperature to enable low fire hold

ConF > AF > HYSt = deadband around low fire hold temperature

2. Wire the LMV37 and RWF55 as shown in Figure 6:

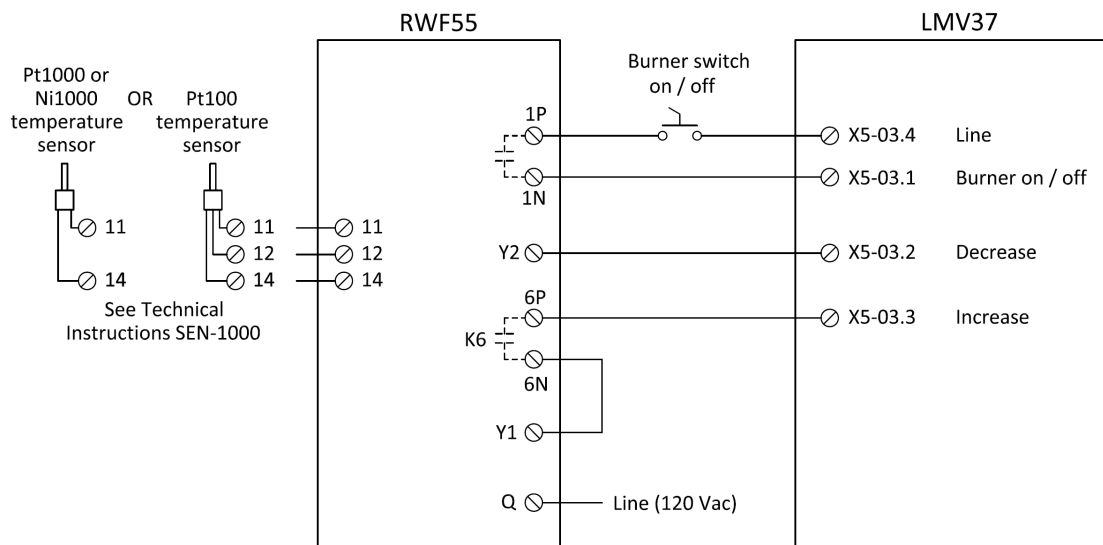

Figure 6: Low Fire Hold via 3-position Output on a Hot Water Boiler

See page 19 for an example of the low fire hold operation.

Low Fire Hold with an RWF55 (continued)

Operation

1. When the boiler temperature falls below the low fire hold temperature threshold ($AL - 1/2 \text{ HYSt}$), contact K6 opens and prevents the LMV3 from increasing the firing rate. This is the case for either analog or 3-position output from the RWF55.
2. Once the boiler warms up above the low fire hold threshold ($AL + 1/2 \text{ HYSt}$), contact K6 closes and the burner modulates according to the PID settings of the RWF55.

Example

Low fire hold threshold settings:

AL = 180

HYSt = 10

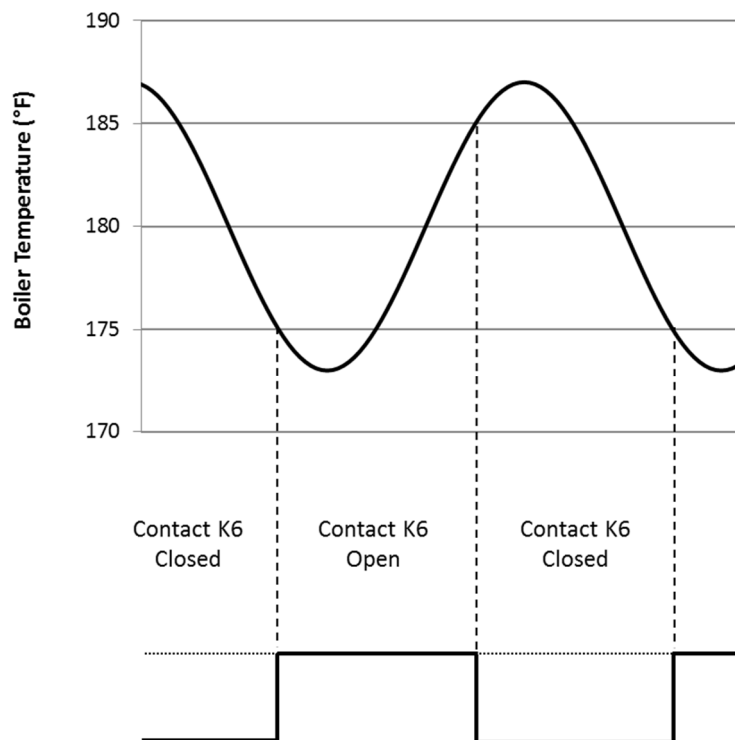

Figure 7: Behavior of Contact K6 when Using an RWF55 for Low Fire Hold

Pilot Valve Proving

Introduction

Valve proving detects if the main gas valves in a gas train are leaking. In addition to checking the main gas valves, the pilot valves may be tested for leakage as well. There are three options for performing pilot valve proving:

- Option 1: On Startup with SKP25's on both the Pilot and Main Gas Trains
- Option 2: On Startup, SKP25 on the Main Gas Train, Solenoid Valves on the Pilot Train
- Option 3: Pilot Valve Proving on Startup and Main Valve Proving on Shutdown

On the LMV3, valve proving of the main gas valves can be performed during startup, during shutdown, or during both startup and shutdown of the boiler. If pilot valve proving is added using Option 1 or Option 2, valve proving must be performed during startup of the boiler only. If pilot valve proving is added using Option 3, valve proving must be performed during both startup and shutdown of the boiler.

Pilot valve proving can be performed on any LMV3.

Procedure

1. The valve proving type can be set in the LMV3 using parameter 241. For Option 1 or Option 2, this must be set to a 1 (valve proving on startup only). For Option 3, this must be set to a 3 (valve proving on both startup and shutdown).
2. The times for each of the four stages of valve proving need to be set. To do so, use the following parameters in the LMV3:

Parameter 242 is the time that the downstream valve is energized in order to evacuate the chamber between the upstream and downstream valves (phase 80). This is typically set to 3 seconds, but should not be set any less than the opening time of the valves.

Parameter 244 is the time that the upstream valve is energized in order to pressurize the chamber between the upstream and downstream valves (phase 82). This is typically set to 3 seconds, but should not be set any less than the opening time of the valves.

Parameter 243 is the time that both the upstream and downstream valves are closed to test the leakage rate of the upstream valve (phase 81). Parameter 245 is the time that both the upstream and downstream valves are closed to test the leakage rate of the downstream valve (phase 83). Both of these times should be set to the same value. These times can be calculated using the following equation:

Pilot Valve Proving (continued)

$$t_{test} = \frac{(P_i - P_{set}) \times V \times 3600}{P_{atm} \times Q_{leak}}$$

t_{test} = Time for setting parameters 243 and 245 in seconds

P_i = Inlet gas pressure (pressure upstream of both valves) in PSIG

P_{set} = Gas pressure setting on pressure switch in PSIG (should be set for half of P_i)

P_{atm} = Atmospheric pressure downstream of both valves in PSIA (typically 14.7 PSI)

V = Volume between the gas valves to be tested in ft^3

Q_{leak} = Allowable leakage rate in ft^3/hr

For Option 3, these times should be calculated independently for the pilot and main valves, and the larger of the calculated times should be used as the parameter setting.

3. Parameter 226 (fuel 0) and 326 (fuel 1) should be set for the default of 2 seconds.

Pilot Valve Proving (continued)

Option 1: On Startup with SKP25's on both the Pilot and Main Gas Trains

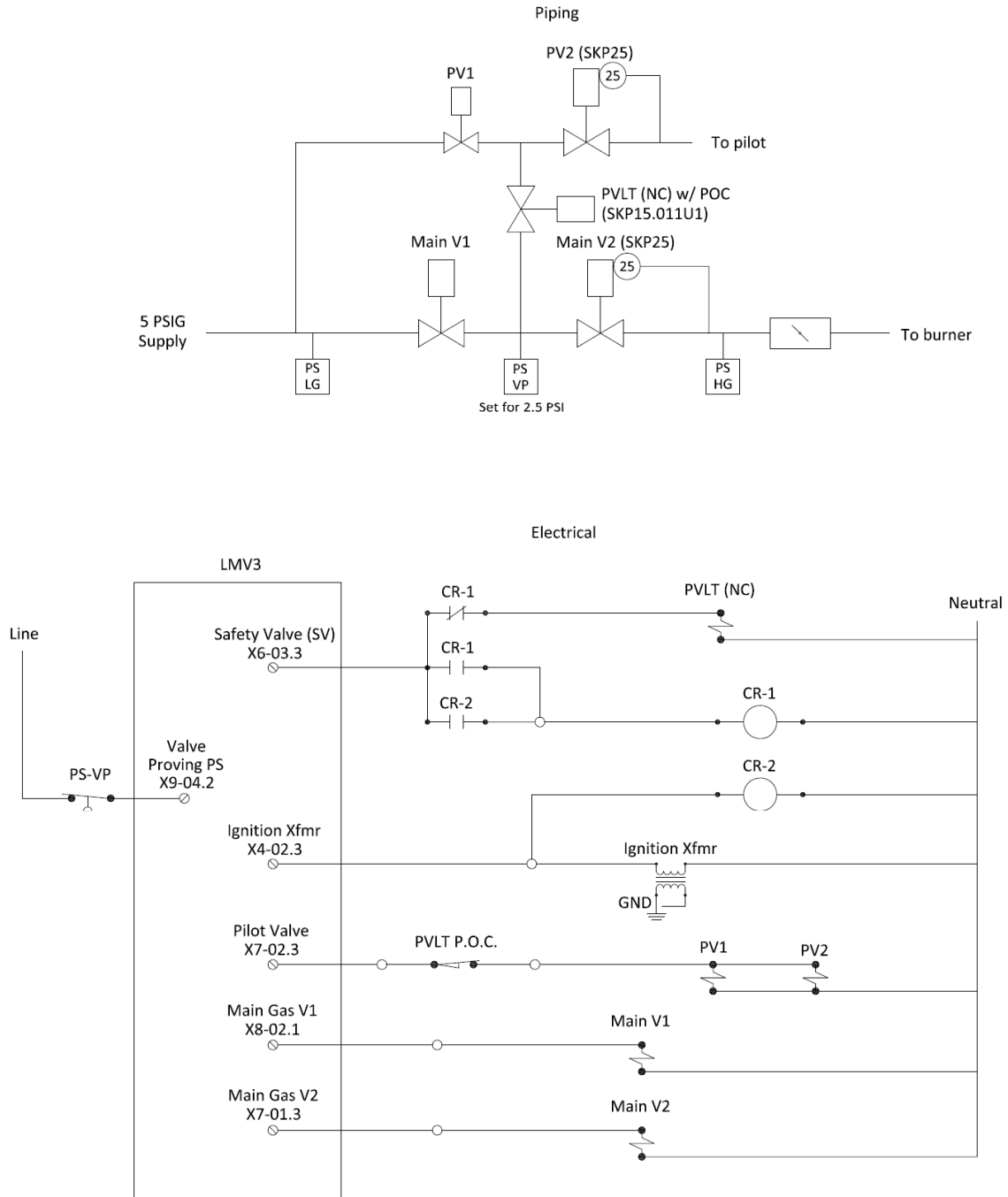

Figure 8: Option 1 Piping and Electrical Schematics

Pilot Valve Proving (continued)

Option 1 Sequence of Operation

1. The LMV3 is in standby. All valves are closed and all relay contacts are as shown in the electrical schematic.
2. The LMV3 receives a call for heat. The SV terminal (X6-03.3) energizes with the blower, energizing the PVLT (Pilot Valve Leak Test). The PVLT opens, and connects the volumes between the pilot valves and main valves. The PVLT POC switch also opens, preventing the operation of the pilot valves.
3. During prepurge, the main valve proving sequence takes place as normal. The PS-VP (Pressure Switch - Valve Proving) is wired to terminal X9-04.2 as normal. The setpoint of the PS-VP should be set for half of the inlet pressure.
4. The LMV3 drives to ignition position. The ignition transformer output (X4-02.3) energizes, thereby energizing the CR-2 coil, and latching the CR-1 coil from the power supplied from X6-03.3. At the same time, one of the CR-1 contacts opens, thereby closing the PVLT and closing the PVLT POC switch. Note that the PVLT POC switch must be closed before the pilot valves open.
5. The LMV3 continues light off and runs as normal, with the CR-1 coil latched in and the PVLT closed.
6. Upon shutdown, the SV terminal (X6-03.3) de-energizes, which un-latches the circuit. The PVLT remains closed until the next start up.

Option 1 Important Notes

1. The proof of closure switch on the PVLT ensures that gas is unable to flow between the pilot and main valves before the pilot attempts to light.
2. All four valves are tested at the inlet pressure, which is the pressure that they normally operate at. The PS-VP should be set for half of the inlet pressure which provides a valid test for all four valves.
3. Valve proving must be done on startup only.

Pilot Valve Proving (continued)

Option 2: On Startup, SKP25 on the Main Gas Train, Solenoid Valves on the Pilot Train

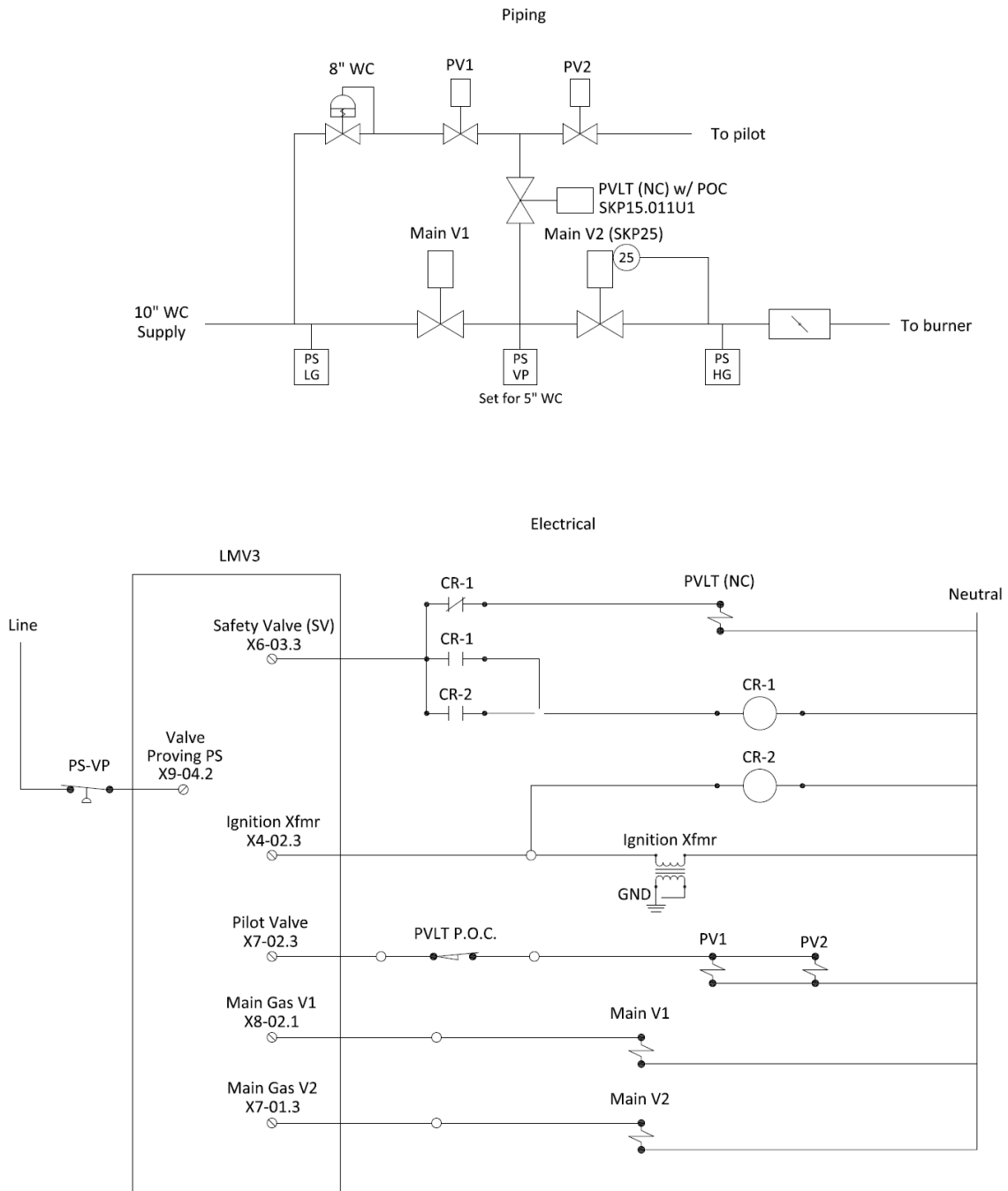

Figure 9: Option 2 Piping and Electrical Schematics

Pilot Valve Proving (continued)

Option 2 Sequence of Operation

1. The LMV3 is in standby. All valves are closed and all relay contacts are as shown in the electrical schematic.
2. The LMV3 receives a call for heat. The SV terminal (X6-03.3) energizes with the blower, energizing the PVLT (Pilot Valve Leak Test). The PVLT opens, and connects the volumes between the pilot valves and main valves. The PVLT POC switch also opens, preventing the operation of the pilot valves.
3. During prepurge, the main valve proving sequence takes place as normal. The PS-VP (Pressure Switch - Valve Proving) is wired to terminal X9-04.2 as normal. The setpoint of the PS-VP should be set for half of the inlet pressure.
4. The LMV3 drives to ignition position. The ignition transformer output (X4-02.3) energizes, thereby energizing the CR-2 coil, and latching the CR-1 coil from the power supplied from X6-03.3. At the same time, one of the CR-1 contacts opens, thereby closing the PVLT and closing the PVLT POC switch. Note that the PVLT POC switch must be closed before the pilot valves open.
5. The LMV3 continues light off and runs as normal, with the CR-1 coil latched in and the PVLT closed.
6. Upon shutdown, the SV terminal (X6-03.3) de-energizes, which un-latches the circuit. The PVLT remains closed until the next start up.

Option 2 Important Notes

1. The proof of closure switch on the PVLT ensures that gas is unable to flow between the pilot and main valves before the pilot attempts to light.
2. Inlet pressure and pilot pressure must be similar (within ~30%) to have a valid test for all four valves.
3. Valve proving must be done on startup only.

Pilot Valve Proving (continued)

Option 3: Pilot Valve Proving on Startup and Main Valve Proving on Shutdown

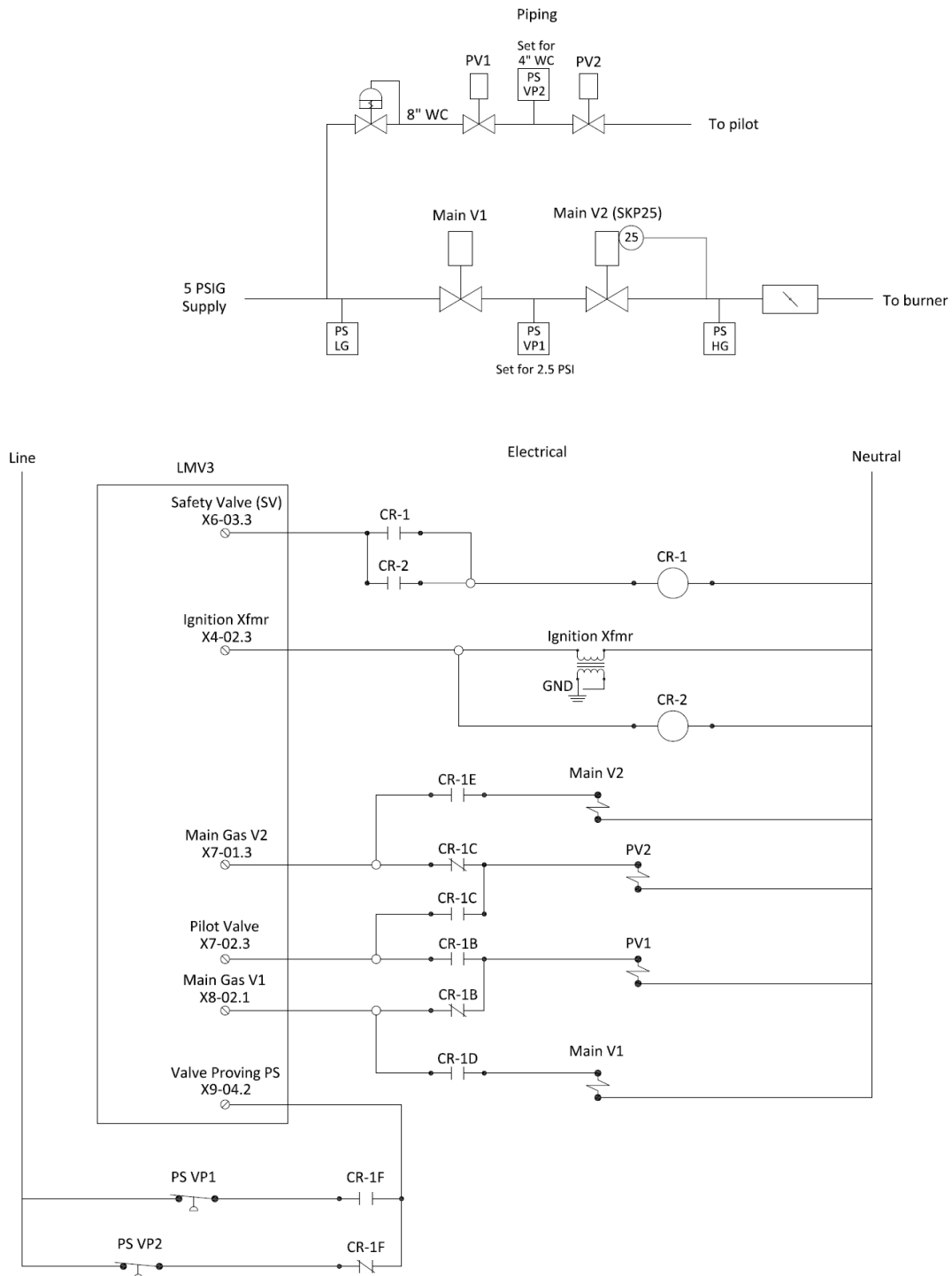

Figure 10: Option 3 Piping and Electrical Schematics

Pilot Valve Proving (continued)

Option 3 Sequence of Operation

1. The LMV3 is in standby. All valves are closed and all relay contacts are as shown in the electrical schematic. Main gas valve V1 terminal X8-02.1 is effectively connected to PV1, and main gas valve V2 terminal X7-01.3 is effectively connected to PV2.
2. The LMV3 receives a call for heat. The SV terminal (X6-03.3) energizes with the blower, which has no effect. The LMV3 drives to prepurge position.
3. During prepurge, the valve proving sequence takes place on the pilot valves only. PS-VP2 (the Pressure Switch Valve Proving between the pilots) is effectively connected to the valve proving terminal (X9-04.2). The setpoint of PS-VP2 should be set for half of the inlet pressure to the pilot valves.
4. The LMV3 drives to ignition position. The ignition transformer output (X4-02.3) energizes, thereby energizing the CR-2 coil, and latching the CR-1 coil from the power supplied from X6-03.3. The main gas valve V1 terminal (X8-02.1) is connected to main gas valve V1, and the main gas valve V2 terminal (X7-01.3) is connected to main gas valve V2. The pilot valve terminal (X7-02.3) is connected to both PV1 and PV2. Also, PS-VP1 is now connected to the valve proving terminal (X9-04.2).
5. The LMV3 continues to light off and runs as normal, with the CR-1 coil latched in.
6. Upon shutdown, the LMV3 proceeds directly into valve proving on shutdown. The SV terminal (X6-03.3) is still energized, so the main valves will go through valve proving using PS-VP1. The setpoint of PS-VP1 should be set for half of the main inlet pressure.
7. After valve proving on shutdown is complete, the SV terminal (X6-03.3) de-energizes and the CR-1 circuit unlatches.

Option 3 Important Notes

1. Separate pressure switches for the pilot valves and main valves are required.
2. All four valves are tested independently.
3. Valve proving must be done on both startup and shutdown of the boiler.
4. CR-1 should be a force-guided safety relay

Purge Proving

Introduction

Purge proving verifies either a differential air pressure switch or an air damper end switch is in the correct position before purge begins. This can be accomplished in two different ways:

- A differential pressure switch to verify proper air flow through the boiler. Once the proper differential pressure is achieved, the prepurge position has been verified and the purge begins.
- An end switch on the air damper. Once the air damper has moved to its fully open position, the end switch closes and the purge begins.

The following procedure for purge proving on the LMV3 uses an additional two-pole relay with either a differential pressure switch or an air damper end switch.

Procedure

The following procedure uses either a differential pressure switch or an air damper end switch for purge proving on the LMV3. For the rest of this procedure, either switch will be referred to as a “proving switch”.

1. Wire the LMV3, proving switch, and two-pole relay as shown below in Figure 11.

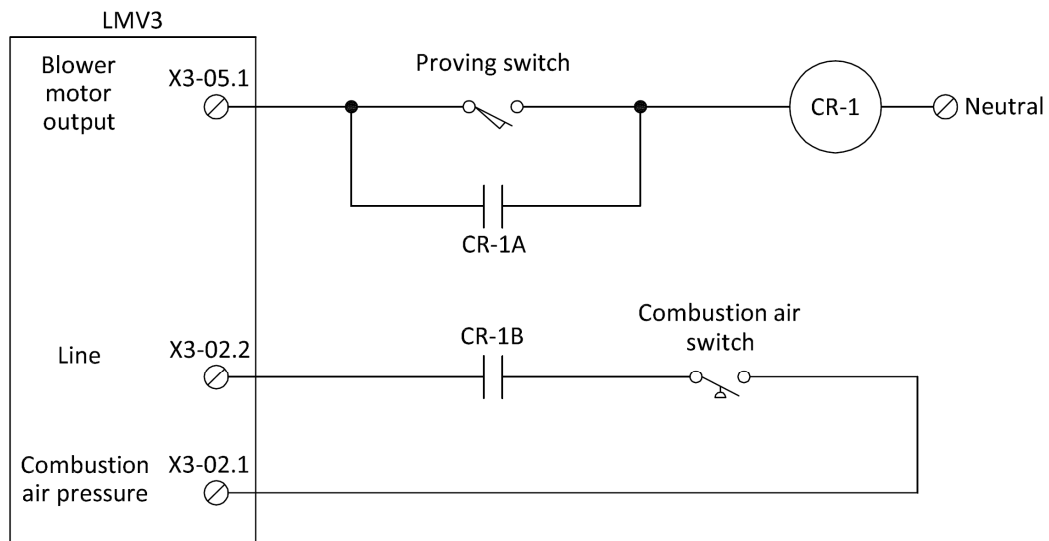

Figure 11: LMV3 Purge Proving Wiring Diagram

Purge Proving (continued)

2. Set parameter 211 (fan run-up time) approximately 5 seconds longer than the amount of time that it takes for the proving switch to close after the fan turns on at the beginning of phase 22.

Operation

1. In phase 22, the blower motor output (X3-05.1) energizes, powering the common side of the proving switch.
2. By the end of phase 24, the combustion air pressure input (X3-02.1) must be energized or the LMV3 will lockout.
3. Once the proving switch closes, relay CR-1 energizes and the two normally-open contacts close.
4. The contact wired in parallel with the proving switch latches power to relay CR-1 as long as the blower is on.
5. The other contact wired to line (X3-02.2) completes the circuit to the combustion air pressure input (X3-02.1), provided that the combustion air switch is also closed. At this point, the purge proving is complete and the LMV3 will progress to phase 30 (prepurge).
6. After postpurge is completed (phase 78), the blower motor output (X3-05.1) de-energizes, removing power from relay CR-1 and breaking the latch circuit.

Revert to Pilot - LMV37 only

Introduction

Revert to pilot is a feature on the LMV37 that allows the burner to re-light the pilot and close the main gas valves (V1 and V2). This is done for two key reasons:

- Eliminating energy losses due to postpurge and prepurge
- Minimizing the time from a demand signal to burner heat production

Procedure

1. Wire the LMV3 and RWF55 load controller as shown below in Figure 12.

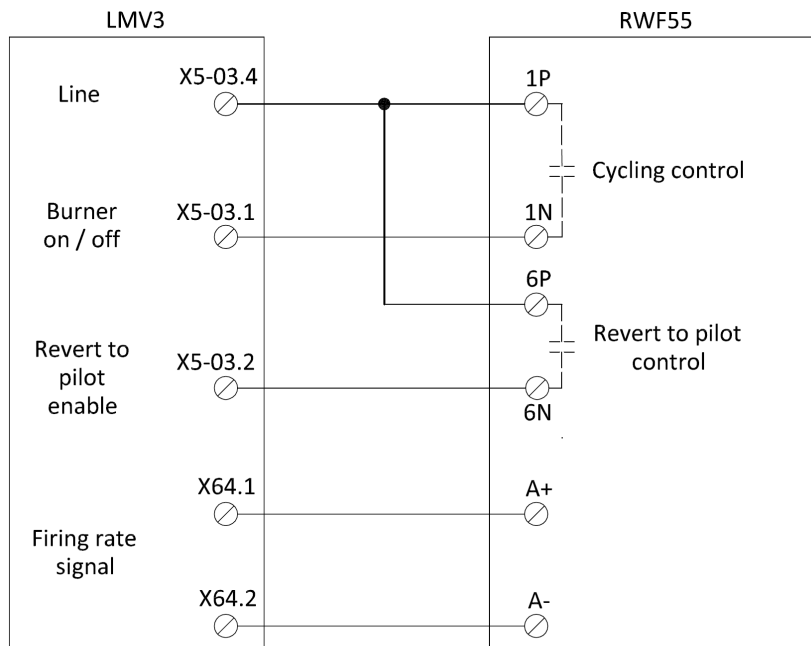

Figure 12: LMV3 / RWF55 Revert to Pilot Wiring

Revert to Pilot - LMV37 only (continued)

2. Set the following parameters in the RWF55 controller. For more information, obtain Siemens Document No. U7867 for the RWF55 at www.scccombustion.com.

ConF > Cntr > CtYP = 2
ConF > Cntr > SPL = setpoint range lower limit
ConF > Cntr > SPH = setpoint range upper limit
OPr > SP1 = normal operation setpoint
PArA > HYS1 = burner on for normal operation
PArA > HYS3 = burner off for normal operation
ConF > InP > InP1 > SEn1 = type of pressure or temperature sensor
ConF > AF > FnCt = 5
ConF > AF > AL = Revert to pilot threshold
ConF > AF > HYSt = Deadband around revert to pilot threshold
ConF > OutP > SiGn = 1

3. Set the following parameters in the LMV37 controller. For more information, see Section 3 of this document.

Parameter 191 = 1
Parameter 192 = Minimum pilot on time
Parameter 193 = Maximum pilot on time

Sequence of Operation

1. The LMV37 is in standby.
2. Pressure or temperature falls. The contact between 6N and 6P on the RWF55 closes, energizing terminal X5-03.2. The LMV37 is still in standby.
3. Pressure or temperature continues to fall. The contact between terminals 1N and 1P on the RWF55 closes, energizing terminal X5-03.1.
4. The LMV37 goes through the startup sequence and lights off normally.
5. The LMV37 reaches normal operation (phase 60). Pressure or temperature rises to the switching point for the "revert to pilot" function. The contact between terminals 6N and 6P on the RWF55 opens, de-energizing terminal X5-03.2.
6. The LMV37 is driven to low fire (phase 62). Then the LMV37 is driven to the ignition position P0 (phase 64).

Revert to Pilot - LMV37 only (continued)

7. Once the ignition position has been reached, the LMV37 pauses for the length of interval 2 - main stabilization (phase 65).
8. After the interval 2 time has expired, both the ignition transformer and pilot valve are energized for the length of safety time 1 (phase 66).
9. After safety time 1 expires, the main valves (V1 and V2) are de-energized (phase 67). Both the ignition transformer and pilot valve remain energized for the length of safety time 1 to ensure that the pilot is stable while the main flame is extinguished.
10. After safety time 1 expires again, the ignition transformer de-energizes, and the pilot valve remains energized (phase 68). The LMV37 is now in “revert to pilot” mode.
11. The LMV37 will remain in “revert to pilot” mode until one of three situations occurs:
 - a. The pressure or temperature falls enough so that the contact between terminals 6N and 6P on the RWF55 closes, re-energizing terminal X5-03.2.
 - b. The maximum pilot on time is reached.
 - c. The pressure or temperature climbs enough so that the contact between terminals 1N and 1P on the RWF55 opens, de-energizing terminal X5-03.1.

If Option “a” occurs:

The LMV37 will proceed with a normal light-off sequence, except that it will start the sequence at the end of the pilot stabilization time (phase 44) and then progress to normal operation (phase 60).

If Option “b” occurs:

The LMV37 will postpurge and then recycle to standby (phase 12) just like a normal shutdown. If the contact between terminals 1N and 1P on the RWF55 is still closed and the contact between terminals 6N and 6P is still open, the LMV37 will go through the startup sequence again and stop in pilot stabilization (phase 44). If the contact between terminals 6N and 6P on the RWF55 closes at any time during the startup sequence, the LMV37 would continue to light off past phase 44 and proceed to normal operation (phase 60).

If Option “c” occurs:

The LMV37 will postpurge and then recycle to standby (phase 12) just like a normal shutdown. The LMV37 will wait in standby until the contact between terminals 1N and 1P on the RWF55 closes, at which time the LMV37 will go through a normal startup sequence and proceed to normal operation (phase 60).

Revert to Pilot - LMV37 only (continued)

Operation Example

Critical RWF55 settings for operation example:

- OPr > SP1 = 90
- PArA > HYS1 = -4
- PArA > HYS3 = 8
- ConF > AF > AL = 3
- ConF > AF > HYSt = 4

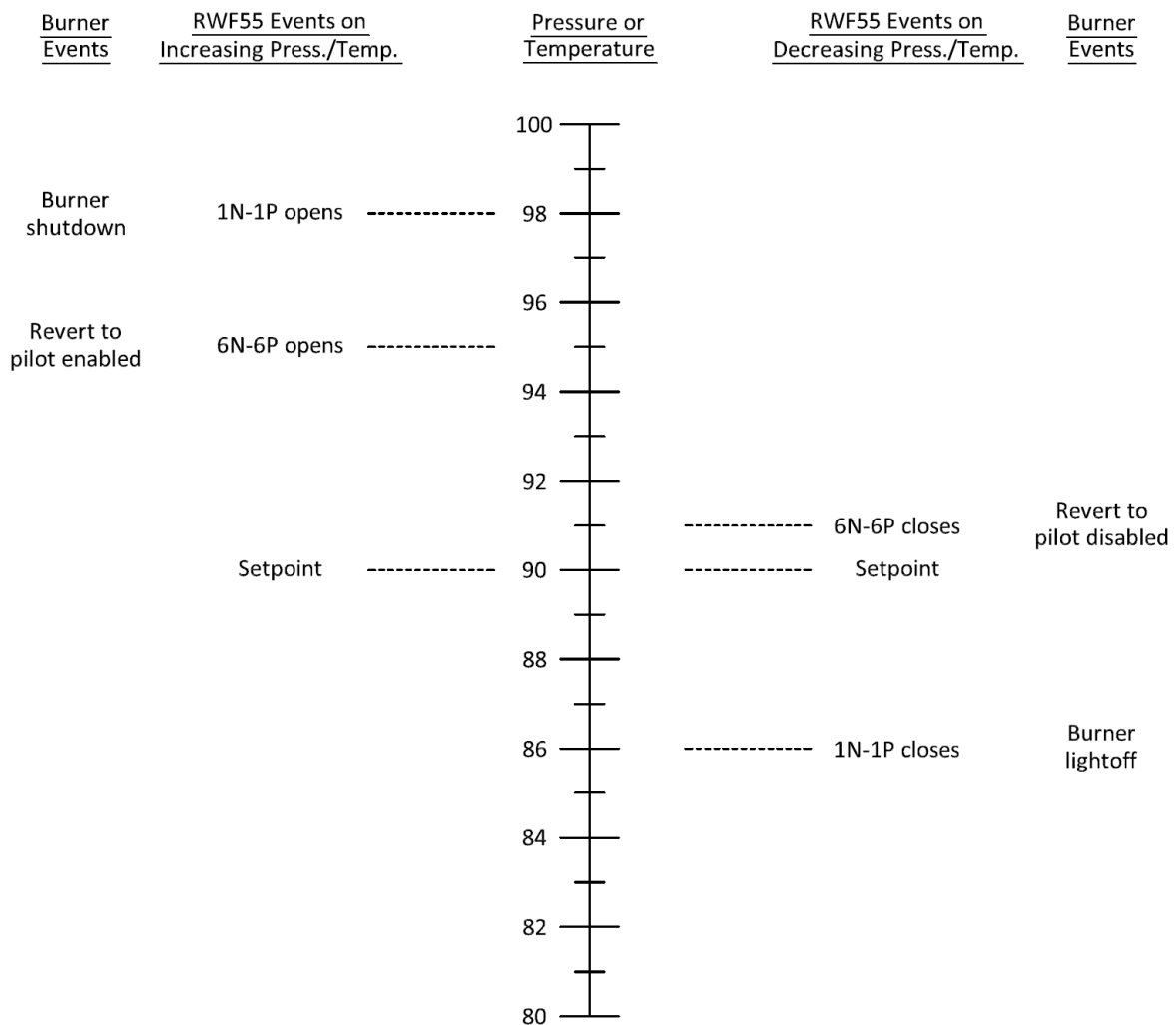

Revert to Pilot - LMV37 only (continued)

Important Notes

1. When the “revert to pilot” function is enabled, float / bump load control via terminal X5-03 is no longer possible. Input X5-03.3 is no longer used and input X5-03.2 is repurposed as the input signal for the “revert to pilot” function.
2. The primary purpose of the maximum pilot on time is so that a burner cannot operate in the “revert in pilot” mode indefinitely.
3. The secondary purpose of the maximum pilot on time is to protect pilot burners that may not be rated for continuous operation.
4. The purpose of the minimum pilot on time is to provide a deadband so that the burner does not constantly revert to pilot and then light off the main burner again repeatedly.
5. Once a “revert to pilot” sequence is initiated, the entire “revert to pilot” sequence must be followed through, including the minimum pilot on time.
6. It is necessary to have the ignition transformer and the pilot valve energized when the main valves (V1 and V2) are closed since the main flame extinguishing typically causes a small pressure pulse that could blow out a pilot that is not supported by an ignition transformer spark.
7. The flame signal is checked at all times during the “revert to pilot” sequence.

Stack Damper

Introduction

In some applications, a stack damper is used to prevent a draft from coming into the boiler when the boiler is shut down. However, the stack damper needs to be open during boiler operation. Typically, it is desired to have the stack damper fully open before the combustion fan turns on, and to leave the damper open until the combustion fan turns off again. The following procedure will describe how to wire a stack damper to the LMV3 so that the damper is open anytime the combustion fan is on.

Procedure

2. Wire the LMV3, RWF5x load controller, and stack damper as shown in Figure 13.

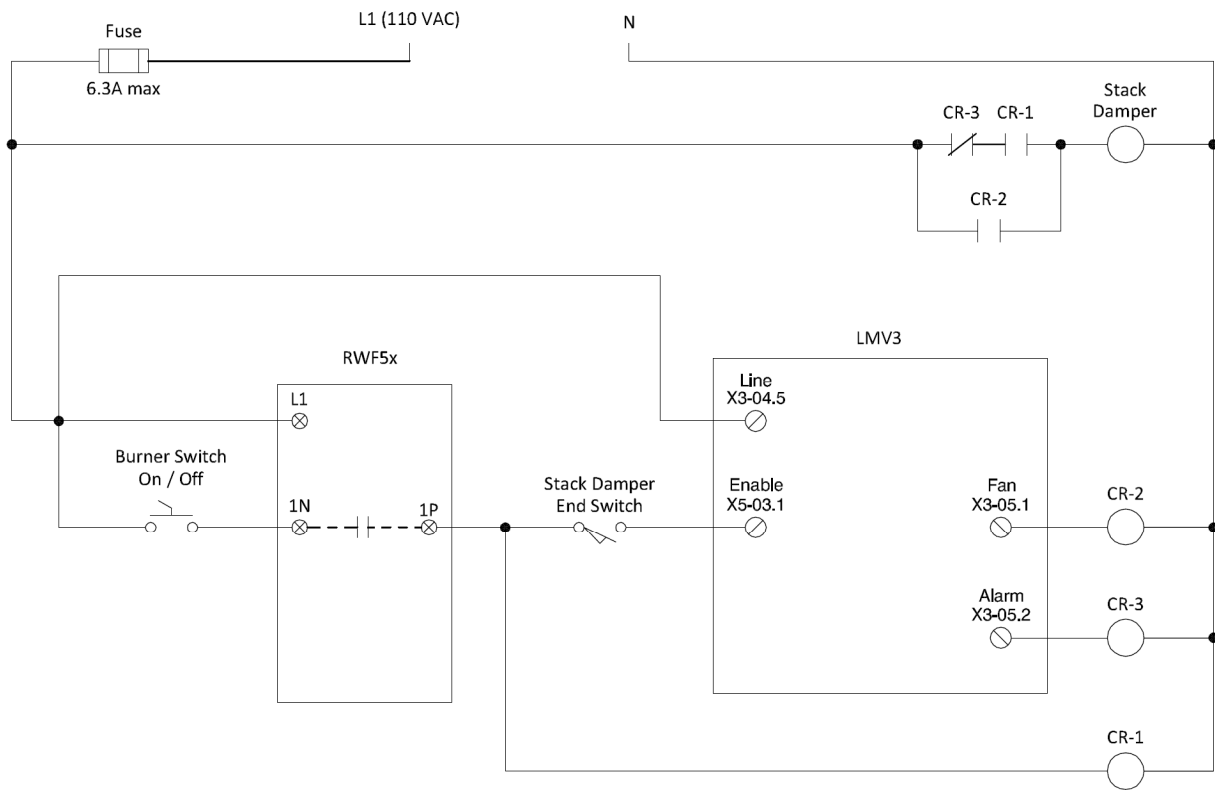

Figure 13: LMV3 Stack Damper Wiring

Stack Damper (continued)

Operation

1. When there is no call for heat from the RWF5x load controller, the internal contact between terminals 1N and 1P will be open. Both CR-1 and CR-2 coils will be de-energized, and the stack damper will be closed.
2. When the RWF5x load controller receives a call for heat, the internal contact between terminals 1N and 1P will close. Terminal 1P will be energized as long as the burner on / off switch is on. Coil CR-1 will be energized, closing the CR-1 contact. As long as the LMV3 is not in alarm (CR-3 contact is closed), the stack damper will begin driving open.
3. Once the stack damper drives fully open, the stack damper end switch will close, and the burner will turn on.
4. The stack damper will remain open until the fan turns off. Once the fan turns off, contact CR-2 will open and un-latch the circuit.

Important Notes

1. The described procedure cannot be used with continuous fan.
2. The burner startup cycle will be lengthened by the stroke time of the stack damper actuator.

Intentionally Left Blank

Technical Instructions
Document No. LV3-1000
July 7, 2017

Global Siemens Headquarters

Siemens AG
Berliner Ring 23
76437 Rastatt
Germany

SCC, Inc.
1250 Lunt Avenue
Elk Grove Village, IL 60007
USA
Telephone: 1-224-366-8445

www.scccombustion.com

Solution
Partner

Combustion
Controls

SIEMENS