

ORDERING INFORMATION

UNIVERSAL MODELS

The ordering part number for the universal model is 82UNIVERSAL. The 82UNIVERSAL comes with remote flame sense active. For internal flame sense, the supplied universal wiring kit must be connected between pins 7 and 10, as shown in FIG.1.

Selectable operation/timing combinations are shown in switch settings, universal models only, TABLE2.

Cross reference information is located in 82universal cross reference, TABLE5.

OEM MODELS

The ordering part numbers for OEM models are shown below. A complete range of fixed operation/timing specifications are factory programmable in order to provide complete cross referencing capability for OEM models.

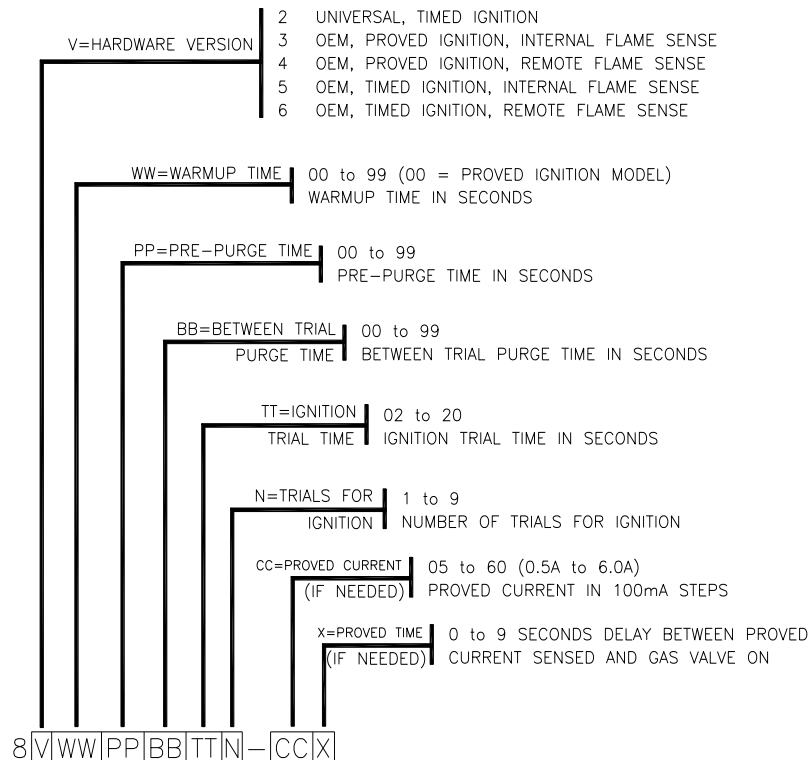

MODEL NO. FORMAT



HOT SURFACE IGNITION CONTROL MODEL SERIES 82 THRU 86

INSTRUCTION MANUAL

⚠ WARNING:

FAILURE TO READ AND FOLLOW ALL INSTRUCTIONS BEFORE INSTALLING OR OPERATING THIS HOT SURFACE IGNITION CONTROL COULD CAUSE PERSONAL INJURY OR EQUIPMENT DAMAGE.

APPLICATION

The 82-86 series of OEM/Universal Hot Surface Ignition Control modules are designed for a variety of OEM applications as well as Universal replacements for a wide range of hot surface ignition controls. Using automatic voltage/frequency sensing, the controls provide operation for direct ignition systems using 120Vac or 240Vac hot surface igniters with flame rectification type flame sensing.

The 82-86 series of controls are microprocessor based and provide reliable software control of all timings, hot surface igniter operation, gas valve operation, flame sensing, and failure recognition with safety shutoff/lockout operation and a corresponding diagnostic LED. Two separately driven relays are used for the gas valve as well as the hot surface igniter to provide an extra level of safety, should a single relay contact fail shorted. Also, a reliable gas valve feedback circuit is used to continuously monitor the gas valve's state and wiring for possible error.

SPECIFICATIONS

- Input Voltage**
Igniter: 120/240 VAC 50/60 Hz
Thermostat: 24 VAC 50/60 Hz
- Input Current Drain (24 VAC)**
0.2A, does not include valve current
- Relay Load Ratings**
Valve: 2A maximum @ 24 VAC
Igniter: 6A maximum @ 120/240 VAC
- Operating Temperature Range**
-40 to +175 degrees F (-40 to +79 degrees C)
- Humidity Range**
5% to 93% relative humidity (non-condensing)
- Pre-Purge Time**
None to 99 seconds, depending on model
- Between Trial Purge Time**
None to 99 seconds, depending on model
- Igniter Warm-Up Time (Timed Ignition Model)**
1 to 99 seconds, depending on model
- Igniter Proving Current (Proved Ignition Model)**
0.5A to 6.0A, depending on model (factory programmable in 100mA steps)
- Igniter Proving Time (Proved Ignition Model)**
1 to 9 seconds, depending on model
- Trials for Ignition**
1 to 9 trials, depending on model
- Ignition Trial Time (Lockout Time)**
2 to 20 seconds, depending on model
- Flame Failure Response Time**
2.0 seconds maximum
- Gas Type**
Natural, LP, or Manufactured

**Automatic Ignition Systems
ANSI Z21.20**



INSTALLATION REVIEW



WARNING:

THE HOT SURFACE IGNITION CONTROL IS NOT REPAIRABLE. ANY MODIFICATION OR REPAIR WILL VOID THE WARRANTY AND AGENCY CERTIFICATION AND MAY CAUSE PROPERTY DAMAGE, PERSONAL INJURY, OR DEATH.



WARNING:

SHOCK HAZARD, FIRE HAZARD, OR EXPLOSION HAZARD. FAILURE TO COMPLY WITH THE FOLLOWING INSTRUCTIONS CAN CAUSE PROPERTY DAMAGE, PERSONAL INJURY, OR DEATH.

Installation should be done by a qualified service technician, qualified heating and air conditioning contractor, or licensed electrician.

Shut off main gas to appliance until installation is finished.

Disconnect electrical power before servicing.

Ensure proper earth grounding of appliance and burner.

Ensure proper connections of line hot and line neutral wires.

Do not exceed the specified voltages and specification ratings.

Ensure the control is protected from any contact with water.

All wiring must conform to local and national electrical codes.

Ensure all wires are labeled before disconnection to prevent wiring errors.

Ensure all wiring is routed and secured away from flame.

Under heavy demand applications, undesirable shutdowns or control failure could occur due to frequent cycling, harsh environmental conditions related to excessive heat, moisture, or corrosive chemicals. In order to help prevent such circumstances, review the following possible conditions and take the precautionary steps, if necessary.

Water Contact

If the hot surface ignition control module gets wet, replace it. Mount the control in an area that avoids the possibility of contact with water or steam at any time.

Frequent Cycling

Typical appliance cycling for this control is around 3 to 4 times per hour during the high demand period. However, applications with greater continuous cycling rates can cause the control to wear out more quickly. It is advised to perform a monthly operation check.

High Humidity

Extremely high ambient humidity can cause the hot surface ignition control to corrode and fail. For use in a humid atmosphere, adequate air circulation around the control is required to prevent condensation.

Dust or Grease

Dust or grease accumulation can cause failure of control operation. Avoid dust or grease accumulation in terminal connection areas of the control.

Corrosive Chemicals

Failure of the hot surface ignition control can occur as a result of contact with corrosive chemicals, either directly or through the air. Avoid corrosive chemical contact with the control.

Excessive Heat

Excessively high temperatures can damage the control and cause failure. Assure the maximum ambient temperature at the control does not exceed the maximum temperature rating. If the control will be exposed to high temperatures, use air circulation, insulation, and/or shielding as required to protect the control.

82UNIVERSAL CROSS REFERENCE TABLE 5 (CONTINUED)

Switch Positions ON	White-Rodgers	Robert Shaw	Honeywell	Fenwall
1,2	50E47-30 to 39 50E47-230 to 239	-	-	-
1,2,5	50E47-20 to 29 50E47-220 to 229	-	-	-
1,2,4	50F47-30 to 39 50F47-230 to 239	-	-	-
1,2,4,5	50F47-20 to 29 50F47-220 to 229	-	-	05-356225-151(a,g) 05-356225-152(a,g)
1,2,3	50E47-10 to 19 50E47-210 to 219 50F47-10 to 19 50F47-210 to 219	-	-	-
1,2,3,5	50E47-1 to 9 50E47-201 to 209 50F47-1 to 9 50F47-201 to 209	HS780-17NL-104A HS780-17NR-104A	-	05-356225-051(a,c) 05-356225-052(a,c)
1,2,3,4	-	-	S8910U	-
1,2,3,4,5	-	HS780-34NR-104A	S89C1046 S89C1103	-

- The 82UNIVERSAL and the referenced control ignition trial times are different, however, the ignition trial time is within the design tolerance of the referenced control.
- The 82UNIVERSAL between trial purge time is longer than that of the referenced control.
- The 82UNIVERSAL between trial purge and igniter warmup times are longer than those of the referenced control.
- The 82UNIVERSAL ignition trial time is shorter than that of the referenced control. Be sure to observe appliance operation to assure reliable performance.
- The 82UNIVERSAL pre-purge time is longer than that of the referenced control.
- The 82UNIVERSAL pre-purge and between trial purge times are longer than those of the referenced control.
- The 82UNIVERSAL pre-purge, between trial purge, and igniter warmup times are longer than those of the referenced control.

NOTE: Refer to switch settings, universal models only, TABLE 2, for actual timings.

**82UNIVERSAL
CROSS REFERENCE
TABLE 5 (CONTINUED)**

Switch Positions ON	White-Rodgers	Robert Shaw	Honeywell	Fenwall
1	50E47-50 to 59 50E47-250 to 259	-	-	-
1,5	50E47-40 to 49 50E47-240 to 249	-	-	-
1,4	50F47-50 to 59 50F47-250 to 259	-	-	-
1,4,5	50F47-40 to 49 50F47-240 to 249	-	-	05-356265-151(a,g) 05-356265-152(a,g)
1,3	50E47-70 to 79 50E47-270 to 279 50F47-70 to 79 50F47-270 to 279	HS780-34NL-304A(c)	S89H1003(c) S89G1005(c)	-
1,3,5	50E47-60 to 69 50E47-260 to 269 50F47-60 to 69 50F47-260 to 269	HS780-17NL-304A(b)	-	05-356265-051(a,c) 05-356265-052(a,c)
1,3,4	-	-	S8910U S890G1003(f) S890H1002(f)	-
1,3,4,5	-	-	-	-

- (a) The 82UNIVERSAL and the referenced control ignition trial times are different, however, the ignition trial time is within the design tolerance of the referenced control.
- (b) The 82UNIVERSAL between trial purge time is longer than that of the referenced control.
- (c) The 82UNIVERSAL between trial purge and igniter warmup times are longer than those of the referenced control.
- (d) The 82UNIVERSAL ignition trial time is shorter than that of the referenced control. Be sure to observe appliance operation to assure reliable performance.
- (e) The 82UNIVERSAL pre-purge time is longer than that of the referenced control.
- (f) The 82UNIVERSAL pre-purge and between trial purge times are longer than those of the referenced control.
- (g) The 82UNIVERSAL pre-purge, between trial purge, and igniter warmup times are longer than those of the referenced control.

NOTE: Refer to switch settings, universal models only, TABLE 2, for actual timings.

INSTALLATION



WARNING:

SHOCK HAZARD, FIRE HAZARD, OR EXPLOSION HAZARD. FAILURE TO COMPLY WITH THE FOLLOWING INSTRUCTIONS CAN CAUSE PROPERTY DAMAGE, PERSONAL INJURY, OR DEATH.

Perform Safety Inspection

The appliance and venting system must be subject to a safety check before the hot surface ignition control is installed. If an unsafe condition is detected, remove all power from the appliance and correct the unsafe condition before proceeding with the installation.

Remove Old Control, If Required

First disconnect all power to the old control module. Disconnect and label all wire connections from the old control module. Remove the old control module from its mounting location.

Mount New Control Module

Mount the control in the same location as the old module, if installed as a replacement, or use the control module as a template to mark the mounting hole pattern. Drill new holes as required and fasten securely with two #6 sheet metal or machine screws. The control must be mounted with the terminals facing down, facing sideways left, or facing sideways right. Do not mount the control with the terminals facing the upward position in order to help prevent exposure to water, moisture, corrosive chemicals, grease, and dust.

Connect Wires

Make sure the thermostat is in the OFF position to assure there is no call for heat. All wiring must conform to local and national electrical codes. Do not allow hot surface igniter leadwires to rest against grounded metal surfaces. The burner must be properly grounded in order to accurately sense flame. Determine the control's model number using the model number series guide, TABLE 1, and attach wire connectors according to FIG.1, FIG.2, or FIG.3 that corresponds to the associated model number.

**MODEL NUMBER SERIES GUIDE
TABLE 1**

SERIES	CONTROL TYPE
82	UNIVERSAL, TIMED IGNITION
83	OEM, PROVED IGNITION, INTERNAL FLAME SENSE
84	OEM, PROVED IGNITION, REMOTE FLAME SENSE
85	OEM, TIMED IGNITION, INTERNAL FLAME SENSE
86	OEM, TIMED IGNITION, REMOTE FLAME SENSE

**82UNIVERSAL
CROSS REFERENCE
TABLE 5 (CONTINUED)**

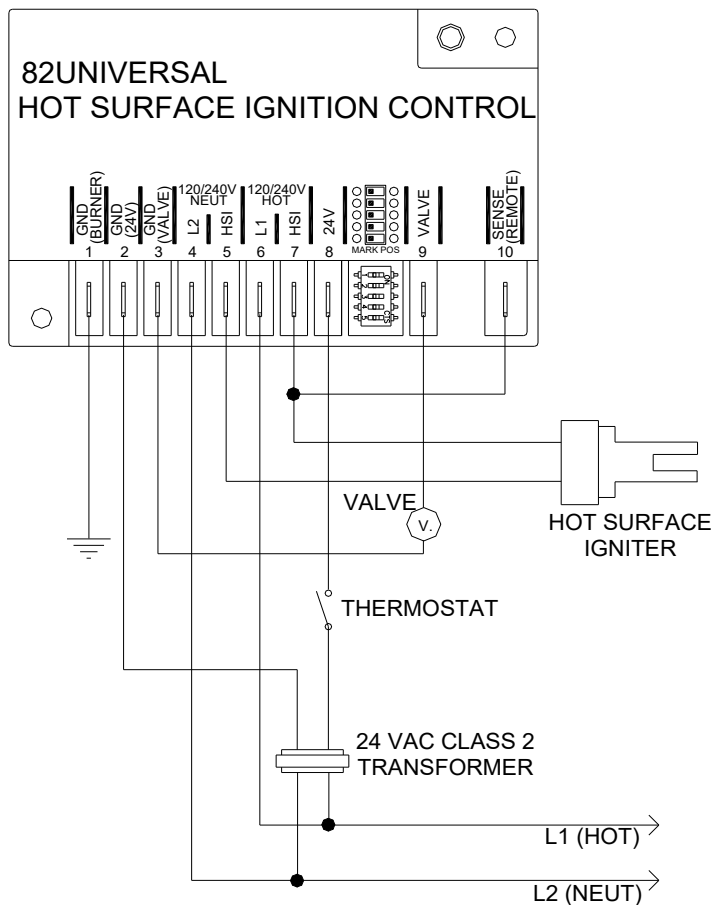

FIG.1 TYPICAL WIRING, 82 SERIES

NOTE: FOR INTERNAL FLAME SENSE ON UNIVERSAL MODEL, CONNECT HSI UNIVERSAL WIRING KIT BETWEEN PINS 7 AND 10 AS SHOWN.

Switch Positions ON	White-Rodgers	Robert Shaw	Honeywell	Fenwall
2	50E47-130 to 139 50E47-330 to 339	-	-	-
2,5	50E47-120 to 129 50E47-320 to 329	-	-	-
2,4	50F47-130 to 139 50F47-330 to 339	-	-	-
2,4,5	50F47-120 to 129 50F47-320 to 329	-	-	05-356225-153(d,g) 05-356225-154(d,g) 05-356225-155(d,g)
2,3	50E47-110 to 119 50E47-310 to 319 50F47-110 to 119 50F47-310 to 319	-	-	-
2,3,5	50E47-101 to 109 50E47-301 to 309 50F47-101 to 109 50F47-301 to 309	HS780-17NL-108A(a)	-	05-356225-053(c,d) 05-356225-054(c,d) 05-356225-055(c,d)
2,3,4	-	-	S8910U S890D1006(a,e) S890C1007(a,e)	-
2,3,4,5	-	HS780-34NL-108A(a)	S89D1002(a) S89C1004(a) S89J1008(a) S89C1012(a) S89C1087(a)	-

- (a) The 82UNIVERSAL and the referenced control ignition trial times are different, however, the ignition trial time is within the design tolerance of the referenced control.
- (b) The 82UNIVERSAL between trial purge time is longer than that of the referenced control.
- (c) The 82UNIVERSAL between trial purge and igniter warmup times are longer than those of the referenced control.
- (d) The 82UNIVERSAL ignition trial time is shorter than that of the referenced control. Be sure to observe appliance operation to assure reliable performance.
- (e) The 82UNIVERSAL pre-purge time is longer than that of the referenced control.
- (f) The 82UNIVERSAL pre-purge and between trial purge times are longer than those of the referenced control.
- (g) The 82UNIVERSAL pre-purge, between trial purge, and igniter warmup times are longer than those of the referenced control.

NOTE: Refer to switch settings, universal models only, TABLE 2, for actual timings.

**82UNIVERSAL
CROSS REFERENCE
TABLE 5**

Switch Positions ON	White-Rodgers	Robert Shaw	Honeywell	Fenwall
none	50E47-150 to 159 50E47-350 to 359	-	-	-
5	50E47-140 to 149 50E47-340 to 349	-	-	-
4	50F47-150 to 159 50F47-350 to 359	-	-	-
4,5	50F47-140 to 149 50F47-340 to 349	-	-	05-356265-153(d,g) 05-356265-154(d,g) 05-356265-155(d,g)
3	50E47-170 to 179 50E47-370 to 379 50F47-170 to 179 50F47-370 to 379	HS780-34NL-306A(a,c) HS780-34NL-308A(a,c) HS780-34NL-312A(c,d) HS780-34NR-306A(a,c) HS780-34NR-308A(a,c) HS780-34NR-312A(c,d)	S89H1011(a,c) S89G1013(a,c) S89G1021(c,d) S89H1029(c,d) S89G1047(a,c)	-
3,5	50E47-160 to 169 50E47-360 to 369 50F47-160 to 169 50F47-360 to 369	HS780-17NR-306A(a,b) HS780-17NR-308A(a,b) HS780-17NL-308A(a,b)	-	05-356265-053(c,d) 05-356265-054(c,d) 05-356265-055(c,d)
3,4	-	-	S8910U S890H1010(a,f) S890G1011(a,f) S890H1028(d,f) S890G1029(d,f) S890G1037(a,f)	-
3,4,5	-	-	-	-

- (a) The 82UNIVERSAL and the referenced control ignition trial times are different, however, the ignition trial time is within the design tolerance of the referenced control.
- (b) The 82UNIVERSAL between trial purge time is longer than that of the referenced control.
- (c) The 82UNIVERSAL between trial purge and igniter warmup times are longer than those of the referenced control.
- (d) The 82UNIVERSAL ignition trial time is shorter than that of the referenced control. Be sure to observe appliance operation to assure reliable performance.
- (e) The 82UNIVERSAL pre-purge time is longer than that of the referenced control.
- (f) The 82UNIVERSAL pre-purge and between trial purge times are longer than those of the referenced control.
- (g) The 82UNIVERSAL pre-purge, between trial purge, and igniter warmup times are longer than those of the referenced control.

NOTE: Refer to switch settings, universal models only, TABLE 2, for actual timings.

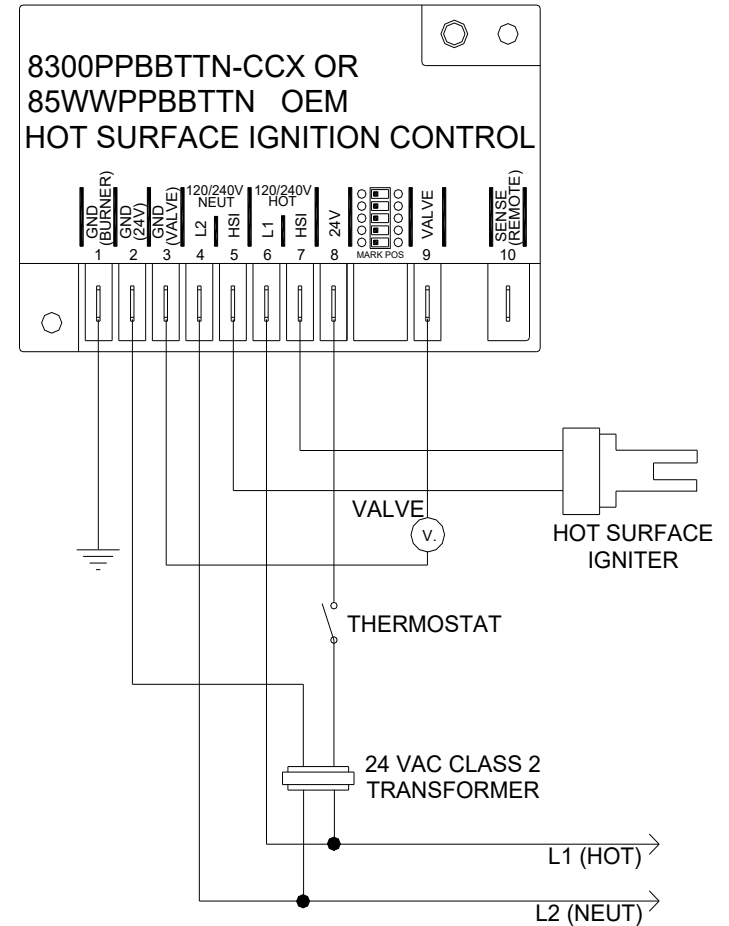

FIG.2 TYPICAL WIRING, 83 SERIES OR 85 SERIES

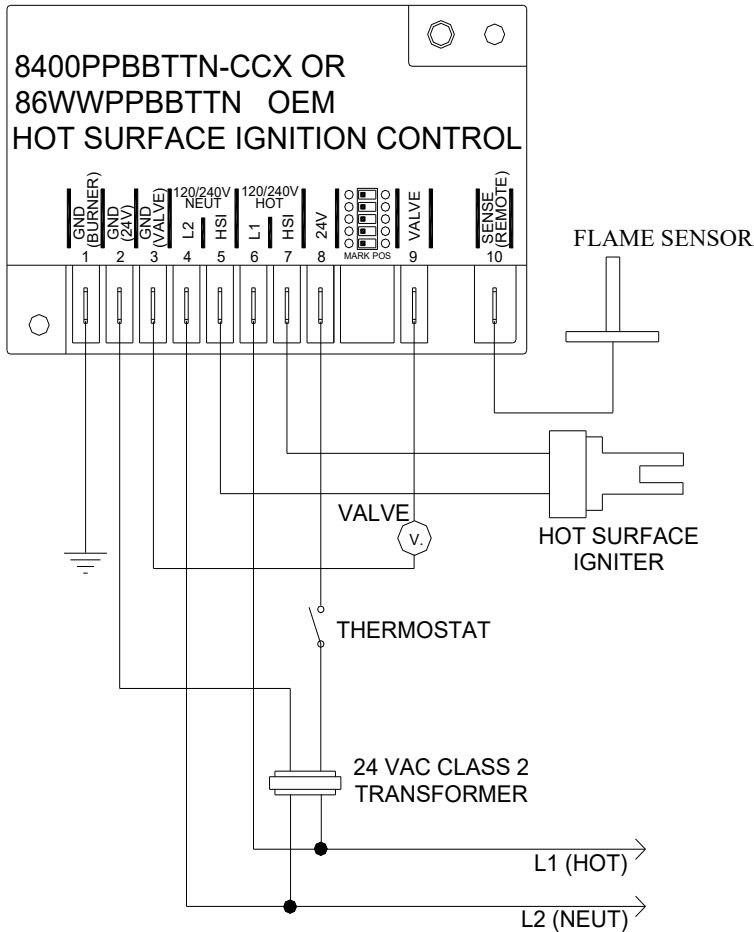
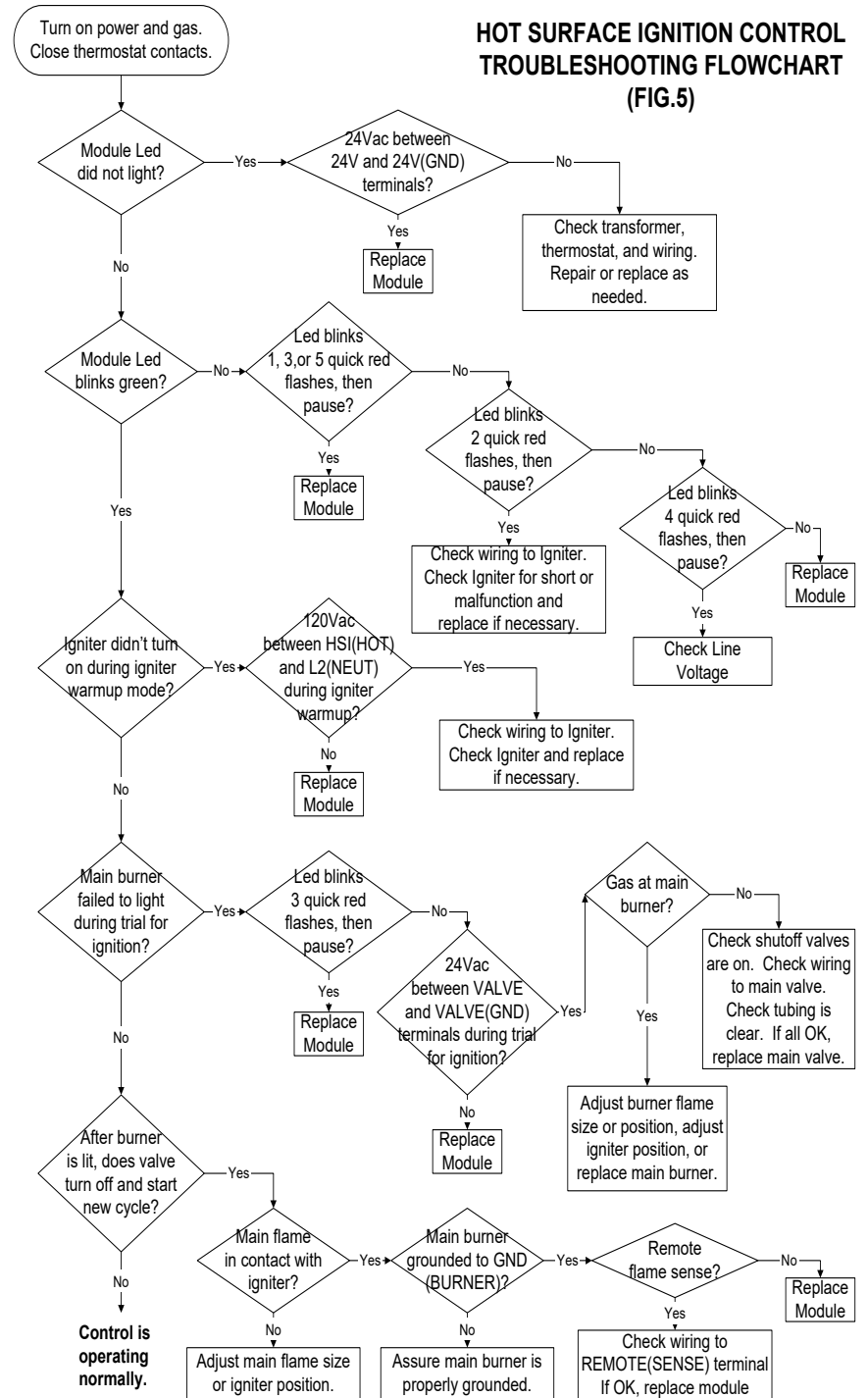

FIG.3 TYPICAL WIRING, 84 SERIES OR 86 SERIES



Led Indications, Normal Operation

Green, ½ sec on, ½ sec off	Pre-purge, Between trial purge, Igniter warmup
Green, on solid	Flame detected, good flame, main burner on
Green, 2 continuous quick flashes	Flame detected, weak flame, main burner on

Led Indications, Error Operation

Upon detection of a fault by the control module's internal diagnostics, all gas valve relays and igniter relays are turned off. The control module then enters lockout mode or standby mode, depending on the error, and flashes a red LED error code. In lockout mode, all operation is disabled. Power removal and/or cycling thermostat to remove the call for heat, thus removing 24VAC from the control module, is required to clear the error. In standby mode, the control disables operation until the error is corrected, at which time the normal operation sequence is initiated again. Refer to error codes, TABLE 3.

ERROR CODES
TABLE 3

Red Flashes	Error Definition	Error Type
1 flash, then pause	Flame Error	Lockout
2 flashes, then pause	Igniter Error*	Lockout
3 flashes, then pause	Gas Valve Error*	Lockout
4 flashes, then pause	Line Voltage/Freq Error	Standby
5 flashes, then pause	Internal Control Error	Lockout

*Note: Igniter Error indicates a problem with the hot surface igniter control, wiring to the igniter, or the hot surface igniter.
Gas Valve Error indicates a problem with the hot surface igniter control, wiring to the gas valve, or the gas valve coil.

TROUBLESHOOTING GUIDE
TABLE 4

Symptom	Possible Causes
1. Control does not power up	A. Faulty 24V wiring B. Thermostat or transformer C. Bad control module
2. Module Led blinks red	A. Determine error code and refer to error codes, CHART 3, and troubleshooting flowchart, FIG.5
3. Igniter not on during igniter warmup mode	A. Faulty igniter wiring B. Bad igniter C. Bad control module
4. Burner does not light during trial for ignition	A. Faulty valve wiring B. Bad valve C. Bad control module
5. Burner lights but valve turns off after trial for ignition	A. Poor flame B. Flame not in contact with igniter or flame sensor C. Dirty contaminated flame sensor D. Faulty flame sensor wiring E. Poor ground at burner

Select Operation Parameter Switch Settings (Universal Series 82 Models Only)

For universal models only, a 5 position dip switch arrangement is provided to allow field programming for 32 possible pre-defined sets of operation/timing combinations. In order to select/change settings, assure all power is removed from control module, change switch settings, and then apply power to the control. The dip switches remain active until 10 consecutive power cycles occur without a change in any dip switch setting. Once this occurs, timing specifications are locked, dip switches become inactive, and cannot further be used to change timing specifications. Refer to switch settings, universal models only, TABLE 2.

SWITCH SETTINGS, UNIVERSAL MODELS ONLY
TABLE 2

Switch Positions					Specifications (Seconds)				
Pos1	Pos2	Pos3	Pos4	Pos5	Warm	Pre-Purge	Bet-Purge	Ign Trial Time	Trials For Ignition
off	off	off	off	off	45	30	90	7	3 trials
off	off	off	off	on	17	30	90	7	3 trials
off	off	off	on	off	45	17	77	7	3 trials
off	off	off	on	on	17	17	77	7	3 trials
off	off	on	off	off	45	0	60	7	3 trials
off	off	on	off	on	17	0	60	7	3 trials
off	off	on	on	off	34	32	96	7	3 trials
off	off	on	on	on	34	0	0	7	3 trials
off	on	off	off	off	45	30	0	7	1 trial
off	on	off	off	on	17	30	0	7	1 trial
off	on	off	on	off	45	17	0	7	1 trial
off	on	off	on	on	17	17	0	7	1 trial
off	on	on	off	off	45	0	0	7	1 trial
off	on	on	off	on	17	0	0	7	1 trial
off	on	on	on	off	34	32	0	7	1 trial
off	on	on	on	on	34	0	0	7	1 trial
on	off	off	off	off	45	30	90	4	3 trials
on	off	off	off	on	17	30	90	4	3 trials
on	off	off	on	off	45	17	77	4	3 trials
on	off	off	on	on	17	17	77	4	3 trials
on	off	on	off	off	45	0	60	4	3 trials
on	off	on	off	on	17	0	60	4	3 trials
on	off	on	on	off	34	32	96	4	3 trials
on	off	on	on	on	34	0	0	4	3 trials
on	on	off	off	off	45	30	0	4	1 trial
on	on	off	off	on	17	30	0	4	1 trial
on	on	off	on	off	45	17	0	4	1 trial
on	on	off	on	on	17	17	0	4	1 trial
on	on	on	off	off	45	0	0	4	1 trial
on	on	on	off	on	17	0	0	4	1 trial
on	on	on	on	off	34	32	0	4	1 trial
on	on	on	on	on	34	0	0	4	1 trial

**USE MARK-
SHOWN, TO
SETTINGS
ING INSTALLATION.**



**ING
INDI-
ON LA-**

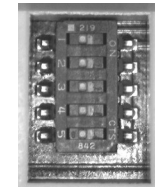

**PEN, AS
CATE SWITCH
BEL FOLLOW-**

SEQUENCE OF OPERATION



WARNING:

SHOCK HAZARD, FIRE HAZARD, OR EXPLOSION HAZARD. FAILURE TO COMPLY WITH THE FOLLOWING INSTRUCTIONS CAN CAUSE PROPERTY DAMAGE, PERSONAL INJURY, OR DEATH.

Normal Operation

Heating cycle starts when call for heat from thermostat supplies 24VAC to 24V terminal. After a 1 second maximum diagnostic period, the control enters pre-purge mode.

Pre-Purge

The control waits for a time delay equal to “pre-purge time”, all gas valve relays and hot surface igniter relays remain off, and the LED flashes green at a rate of ½ second on, ½ second off. Upon expiration of pre-purge time, the control enters igniter warmup mode.

Igniter Warmup

Both hot surface igniter relays are energized, turning on the hot surface igniter. The LED continues flashing green at a rate of ½ second on, ½ second off.

Proved Ignition Models Only (Series 83, 84)

The hot surface igniter stays on while its current is continuously measured. After the igniter current reaches a magnitude of “igniter proving current” in AC RMS Amperes, the igniter continues to stay on for the additional time interval specified by “igniter proving time”, after which the control enters trial for ignition mode.

Note:

If the “igniter proving current” is never reached, the energized igniter times out after 45 seconds, lockout mode occurs, and a 2-flash red LED igniter error is initiated.

Timed Ignition Models Only (Series 82, 85, 86)

The hot surface igniter stays on for “igniter warmup time”, after which the control enters trial for ignition mode.

Trial for Ignition

Both gas valve relays are energized, turning on the gas valve. With the gas valve open, the hot surface igniter remains energized to allow a flame to be established. The igniter is then turned off while the gas valve remains open, at which time the flame rectification sensing circuit determines if the main burner flame is present or not.

Flame Sensed

With flame present, a current path is completed between the igniter and main burner ground on internal flame sense models, or between a flame rod and main burner ground on remote flame sense models. The main burner flame is monitored continuously and both gas valve relays stay energized as long as flame is present. When the call for heat ends, the thermostat removes power to the control module and all relays turn off, thus closing the gas valve and extinguishing the flame.

Good Flame

LED on solid green, both gas valve relays remain energized.

Weak Flame

LED on, 2 continuous fast green flashes, both gas valve relays remain energized.



WARNING:

SHOCK HAZARD, FIRE HAZARD, OR EXPLOSION HAZARD. FAILURE TO COMPLY WITH THE FOLLOWING INSTRUCTIONS CAN CAUSE PROPERTY DAMAGE, PERSONAL INJURY, OR DEATH.

Flame Not Sensed, Models With 1 Trial for Ignition (Bad Flame/No Flame)

If flame is not sensed by the end of “ignition trial time”, both gas valve relays are turned off. Control module enters lockout mode, turns all relays off, and initiates a 1-flash red LED flame error. Remove and restore power to end lockout mode. Refer to troubleshooting guide, TABLE 4, and troubleshooting flowchart, FIG.5.

Flame Not Sensed, Models With 2 - 9 Trials for Ignition (Bad Flame/No Flame)

If flame is not sensed by the end of “ignition trial time”, both gas valve relays are turned off. Control module initiates a time delay of “between trial purge time”, followed by another igniter warmup period, and another trial for ignition period. If flame is still not sensed, this sequence is repeated until the total number of trials for ignition are completed. If flame is still not sensed, all relays are turned off, the control enters lockout mode, and initiates a 1-flash red LED flame error. Remove and restore power to end lockout mode. Refer to troubleshooting guide, TABLE 4, and troubleshooting flowchart, FIG.5.

Note:

Both silicon carbide and silicon nitride igniters can be used, however it is recommended that silicon nitride igniters be used with remote flame sense only.

Flame Lost

After a flame is established, if a loss of flame occurs during burner operation, both gas valve relays are turned off. The control module then initiates a time delay of “between trial purge time”, followed by an igniter warmup period, and a trial for ignition sequence.

If flame is not sensed, this sequence is repeated until the total number of trials for ignition are completed during this single call for heat. If flame is still not sensed, all relays are turned off, the control enters lockout mode, and initiates a 1-flash red LED flame error. Remove and restore power to end lockout mode. Refer to troubleshooting guide, TABLE 4, and troubleshooting flowchart, FIG.5.

Flame Position

Refer to hot surface igniter location, FIG.4, for required optimal flame contact with igniter. Flame should be mostly blue in color. Yellow flame indicates burner adjustment is recommended.

FIG.4 HOT SURFACE IGNITER LOCATION

