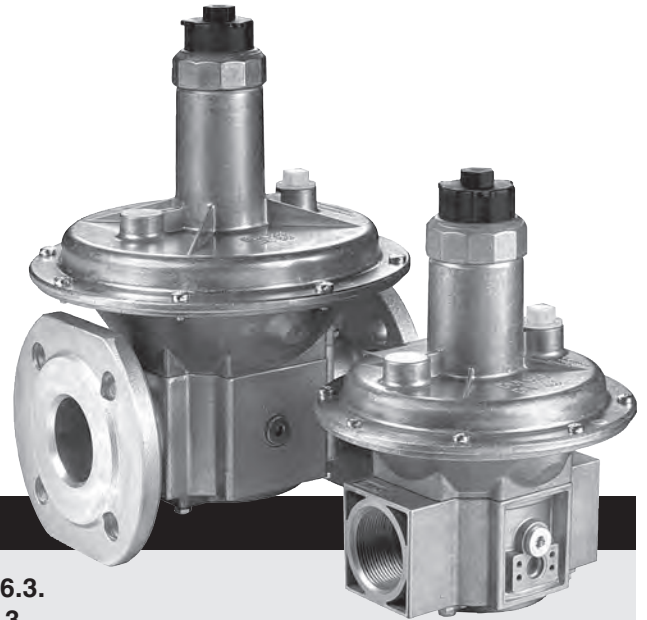



Table of Contents

Table of Contents	Page 1	Repair Kits	Page 10
Approvals	Page 1		
Attention	Page 1		
Specification	Page 2		
Lock-up Pressure Parameters	Page 3		
Regulator Orifice Diameters	Page 3		
Mounting Preparation	Page 3		
Mounting & Installation	Page 4		
Pressure Tap Connections	Page 5		
Outlet Pressure Spring Selection	Page 6		
Breather Plug	Page 6		
Vent Limiting Device & Vent Line Connection	Page 7		
External Impulse	Page 7		
Outlet Pressure Adjustment	Page 8		
Spring Replacement	Page 8		
Flow Curve	Page 9		
Accessories & Replacement	Page 10		



Approvals



FRS 7../6 series are CSA Certified: ANSI Z21.18/CSA 6.3.
FRS 5... series are CSA Certified: ANSI Z21.18/CSA 6.3.

Commonwealth of Massachusetts Approved Product Approval code G1-1107-35

Attention



The installation and maintenance of this product must be done under the supervision of an experienced and trained specialist. Never perform work if gas pressure or power is applied, or in the presence of an open flame.



On completion of work on the pressure regulator, perform a leakage and function test.



Please read the instruction before installing or operating. Keep the instruction in a safe place. You find the instruction also at www.dungs.com. If these instructions are not heeded, the result may be personal injury or damage to property.



This product is intended for installations covered by, but not limited to, the following codes and standards: NFPA 37, NFPA 86, NFPA 54, CSD-1, UL 795, ANSI Z83.4, ANSI Z83.18, ANSI Z21.13, CSA B149.1, CSA B149.3 and CSA B149.6.



Any adjustment and application-specific adjustment values must be made in accordance with the equipment manufacturers instructions.

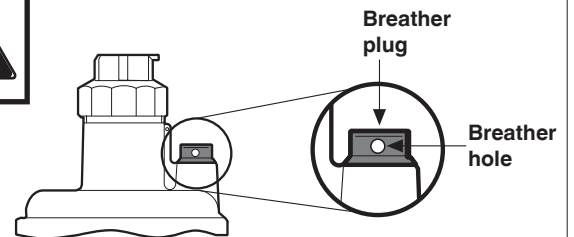

Never close Breather hole!

Explanation of symbols

- 1, 2, 3 ... = Action
- = Instruction

Specification

FRS The FRS series balance type, pressure regulator is a spring-loaded pressure regulator with adjustable setpoint spring and an internal sensor for regulating output pressure.



Max. Operating Pressure (MOP)
 7 PSI (500 mbar) for FRS 7.../6 series.
 10 PSI (680 mbar) for special versions of FRS 7.../6 series (see P/N's below).
 7 PSI (500 mbar) for FRS 5... Flanged series.
 5 PSI (350 mbar) applies to the CSA Certification for FRS 7.../6 and for FRS 5... Flanged series.

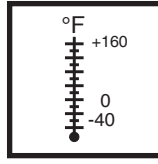

Ambient / Fluid Temperature
 FRS 7.../6 series:

- +5 °F to +160 °F for up to 7 or 10 PSI, depending on model, for regulating behavior (+/- 10 % of setpoint)
- CSA Certified for -40°F to +160 °F: Diaphragms are suitable for the low temperature, but there may be out of range regulating behavior.

Output pressure range
 Adjustable with different springs
 1 to 80 in. W.C.

FRS 5... Flanges series:

- +5 °F to +160 °F (-15 °C to +70 °C for up to 7 PSI).



Maximum pressure drop and gas velocity
 The maximum pressure drop is limited by the velocity of the gas. Do not exceed a gas velocity of 30 meters/s.

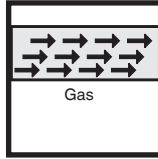

Gases
 Dry, natural gas, propane, butane; other noncorrosive gases. Suitable for up to 0.1% by volume, dry H₂S. A "dry" gas has a dew point lower than +15 °F and its relative humidity is less than 60 %.

Materials in contact with Gas
 Housing: Aluminum & Steel
 Seals & Diaphragm: NBR-based rubber.

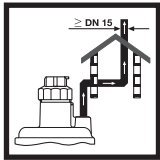

Vent Limiting Device and Vent Line Connection
 The FRS/6 has an internal, factory installed vent limiter, which limits the escape of gas to less than 0.5 CFH @ 5 PSI in case atmospheric diaphragm ruptures. Vent limiting device also complies with EN 88-1 & ISO 23551-2. Venting required unless otherwise accepted by the authority having jurisdiction.



Droop and Hysteresis
 Hysteresis is less than 10 % for up to 7 PSI inlet.
 Average droop at 20:1 turndown is 10 % for up to 7 PSI.

Lock-up Rating

- The FRS meets the ANSIZ.21.80/ CSA 6.22 as Class I, which allows lockup rating not more than 150 % or 5 in. W.C, whichever is greater.
- The FRS meets EN 88-1 as SG30, which allows lock-up as high as +30 % of the outlet pressure.
- See Lock-up Pressure Parameters on page 3 for more details.

Body Size	Size	Order No. 7 PSI max.	Order No. 10 PSI max.
FRS 705/6	1/2" NPT	229-595	229-595-10
FRS 707/6	3/4" NPT	229-608	229-608-10
FRS 710/6	1" NPT	229-609	229-609-10
FRS 712/6	1 1/4" NPT	229-610	229-610-10
FRS 715/6	1 1/2" NPT	229-611	229-611-10
FRS 720/6	2" NPT	229-612	229-612-10
FRS 725/6	2 1/2" NPT	229-613	229-613-10
FRS 730/6	3" NPT	229-614	229-614-10
FRS 5040	1 1/2" DN (ISO) Flanged	065-144	not available
FRS 5050	2" DN (ISO) Flanged	065-151	not available
FRS 5065	2 1/2" DN (ISO) Flanged	058-792	not available
FRS 5080	3" DN (ISO) Flanged	079-681	not available
FRS 5100	4" DN (ISO) Flanged	082-552	not available
FRS 5125	5" DN (ISO) Flanged	013-250	not available
FRS 5150	6" DN (ISO) Flanged	013-268	not available

Lock-up Pressure Parameters

Per ANSI Z21.80, lock-up is defined as an outlet pressure not more than 150 % or 5 in. W.C, whichever is greater, above the setpoint after a downstream safety shutoff valve closes with 2 seconds, and the two following conditions exists:

1. outlet pressure is set to the highest set point of the spring, and
2. the regulator is set to maximum capacity or flow at which the regulator will control lockup pressure within the acceptable limits.

This means that in a given application, a lockup greater than 150 % or 5 in. W.C could occur, depending out the inlet pressure, the outlet pressure of the regulator, the flow rate of the regulator, and the pipe volume downstream the regulator and upstream the safety shutoff valve.

Per DUNGS, lock-up is +30 % of the outlet pressure setting after downstream shutoff valve slowly closes within 30 seconds. Therefore, in a given application, a lockup greater than +30 % or 5 in. W.C could occur, depending out the inlet pressure, the outlet pressure of the regulator, the flow rate of the regulator, and the pipe volume downstream the regulator and upstream the safety shutoff valve.

If in a given application the lock-up pressure is too high, imploring one or more of the following should reduce the lock-up pressure:

1. Increase the size of the regulator.
2. Increase the pipe volume downstream the regulator and upstream the safety shutoff valve.
3. Decrease the inlet pressure.
4. Decrease the outlet pressure.
5. Reduce the flow rate.
6. Disconnect vent line, if installed.

Regulator Orifice Diameters

Regulator Type	Orifice Diameter (mm)
FRS 705/6	28.0
FRS 707/6	34.0
FRS 710/6	39.0
FRS 712/6	43.5
FRS 715/6	43.5
FRS 720/6	57.5
FRS 725/6	68.0

Mounting Preparation

Mounting Preparation FRS 7../6 & FRS 5... Flanged

- The main gas supply must be shut off before starting the installation.
- Carefully examine the unit for shipping damage.
- Remove all dirt and debris before installing.
- Failure to remove dirt/debris could result in damage or improper performance.

Recommended Mounting Procedure

Regulator dome from vertically upright to horizontal

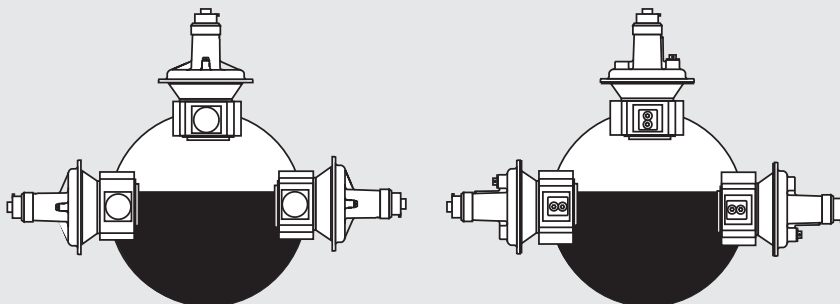

! If the flow is not in the same direction of the arrows, the regulator will not operate properly.

Mounting & Installation

Procedure to Mount the FRS 7../6

- Install the FRS.../6 with the gas flow matching the direction indicated by the arrows on the casting.
- Mount the FRS.../6 with the regulator dome vertical or horizontal.
- Use new, properly reamed and NPT threaded pipe free of chips.
- Apply good quality pipe sealant, putting a moderate amount on the male threads only. If using LP gas, use pipe sealant rated for use with LP gas.
- Do not thread pipe too far. FRS.../6 distortion and/or malfunction may result from excess pipe in the valve body.
- Apply counterpressure with a parallel jaw wrench only to the flats of the FRS.../6 when installing pipe.
- Do not overtighten the pipe. Follow the maximum torque values listed.

- After installation is complete, perform a leak test using a soapy water solution.



Quickly opening the inlet manual shutoff valve can permanently rupture the internal, balancing diaphragm.

- Install the FRS 5... with the gas flow matching the direction indicated by the arrows on the casting.
- Mount the FRS 5... with the regulator dome vertical or horizontal.
- Insert seal inbetween flanges.
- Insert bolts, tighten in a star pattern to ensure uniform tightness.
- Do not overtighten bolts. Follow the maximum torque values listed.
- After installation is complete, perform a leak test using a soapy water solution.

FRS 7../6 Threaded Series

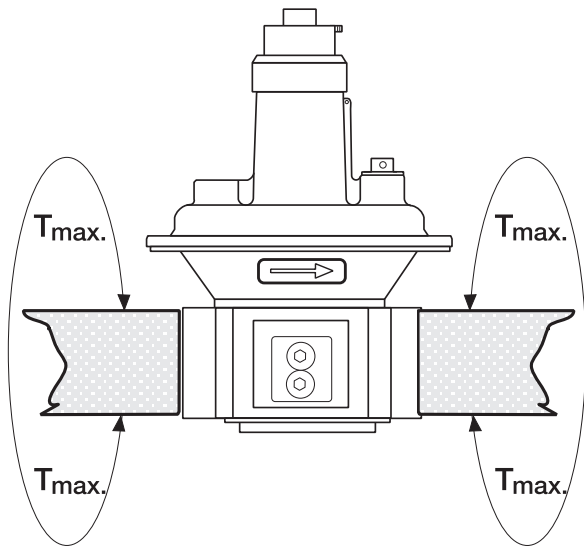

NPT pipe	1/2"	3/4"	1"	1 1/4"	1 1/2"	2"	2 1/2"	3"
T _{max} [lb-in]	443	560	750	875	940	1190	1310	1310

FRS 5... Flanged Series

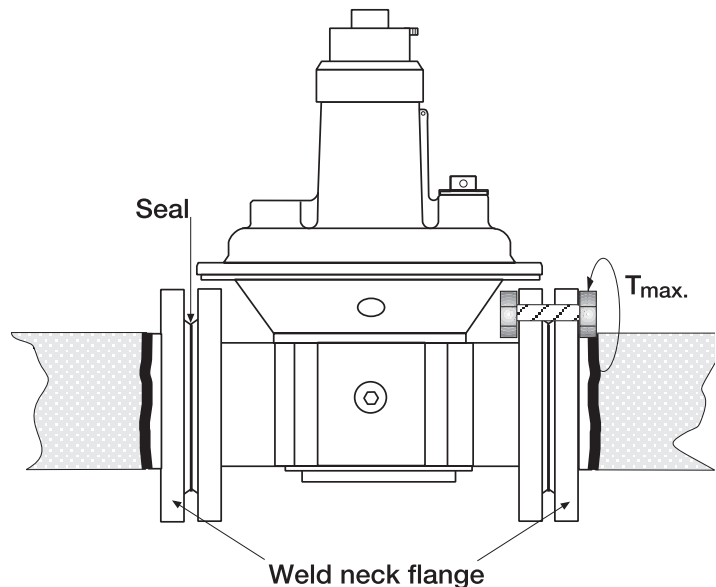

Bolts: as per DIN 939

T_{max} [lb-in] 443

NOTE: There are no limits for required pipe lengths immediately downstream of the FRS.



Do not overtorque threaded connection or bolts. Permanent damage will occur.



If the flow is not in the same direction as the arrows, the FRS will not operate properly.

Pressure Tap Connections

Pressure Taps - FRS 7../6 Threaded Version

- 1 Vent/breather connection
FRS 705/6 - FRS 710/6, G 1/4 in.
FRS 712/6 - FRS 730/6, G 1/2 in.
- 2 External feedback pressure connection
FRS 705/6 - FRS 710/6, G 1/4 in. - one side.
FRS 712/6 - FRS 730/6, G 1/4 in. - both sides.
- 3 Upstream pressure connection
FRS 705/6 - FRS 710/6, 1/4 in. NPT - one side.
FRS 705/6 - FRS 710/6, G 1/4 in. - one side.
FRS 712/6 - FRS 730/6, 1/4 in. NPT - both sides.
- 4 Downstream pressure connection
FRS 705/6 - FRS 710/6, 1/4 in. NPT - one side.
FRS 712/6 - FRS 730/6 1/4 in. NPT - both sides.

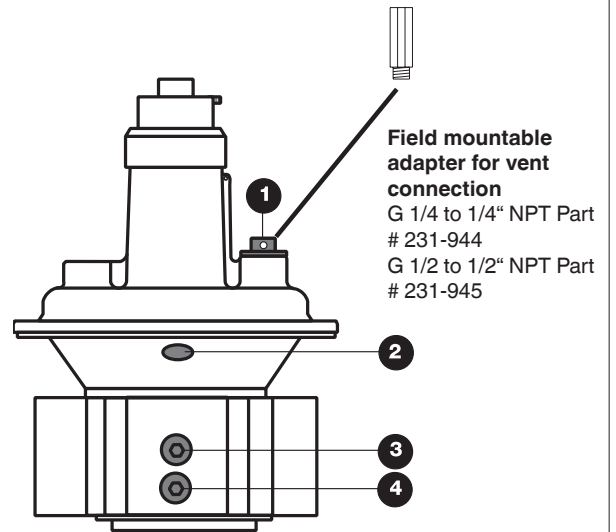

Pressure Taps - FRS 5... Flanged Version

FRS Flanged

- 1 Vent/breather connection
FRS 5040 - FRS 5150, G 1/2 in.
- 2 External feedback pressure connection
FRS 5040 - FRS 5150, both sides G 1/4 in.
See caution below.
- 3 Upstream pressure connection
FRS 5040 - FRS 5150, both sides G 1/4 in.

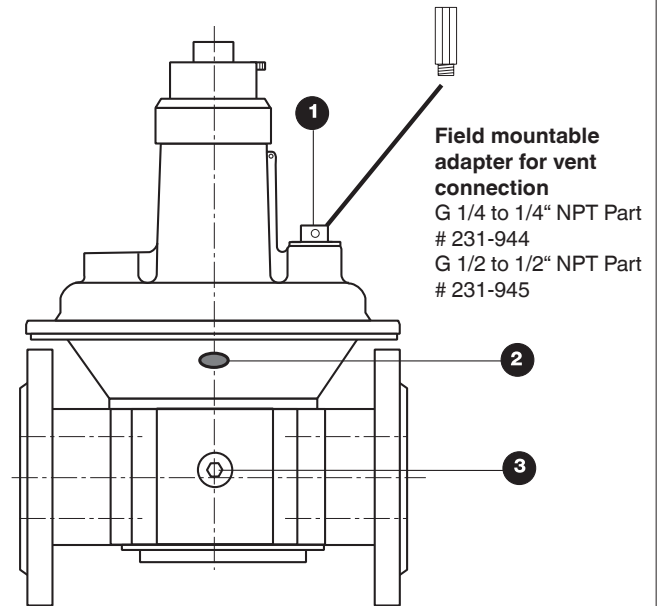

When using external feedback pressure connection, the internal feedback tube must be sealed with RTV.

Outlet Pressure Spring Selection

Outlet Pressure Spring Selection (outlet pressure values are for horizontal pipe mounting)

The output pressure is controlled by the force of the adjustable spring. The pressure regulator is supplied with the blue spring No. 4. By exchanging springs, other output pressures can be attained. Subtract 1"W.C. when mounted vertically.

Spring Range (W.C.) Spring color	1 to 3.6 brown Not CSA	2 to 5 white	2.8 to 8 orange	4 to 12 blue Standard	10 to 22 red	12 to 28 yellow	24 to 40 black	40 to 60 pink	60 to 80 grey Not CSA
FRS 705/6	229-817	229-818	229-820	229-821	229-822	229-823	229-824	229-825	229-826
FRS 707/6	229-833	229-834	229-835	229-836	229-837	229-838	229-839	229-840	229-841
FRS 710/6	229-842	229-843	229-844	229-845	229-846	229-847	229-848	229-849	229-850
FRS 712/6, 715/6, 5040	229-851	229-852	229-853	229-854	229-869	229-870	229-871	229-872	229-873
FRS 720/6 & 5050	229-874	229-875	229-876	229-877	229-878	229-879	229-880	229-881	229-882
FRS 725/6, 730/6, 5065, 5080	229-883	229-884	229-885	229-886	229-887	229-888	229-889	229-890	229-891
FRS 5100	229-892	229-893	229-894	229-895	229-896	229-897	229-898	229-899	229-900
FRS 5125	229-901	229-902	229-903	229-904	229-905	229-906	229-907	229-908	243-416
FRS 5150	229-909	229-910	229-911	229-912	229-913	229-914	229-915	229-916	243-417

Breather Plug

- All FRS's have a breather plug that threads into the regulator's vent connection.

Do not removed plastic breather plug unless venting outdoors is required.

This plug is not the vent limiter, and it prevents debris from entering the upper chamber of the regulator. Debris in the upper chamber of the regulator could adversely affect regulator performance.

- The FRS regulator must also be able to exchange air through the breather hole in order to properly regulate. Do not plug the breather hole. Clear out if necessary.

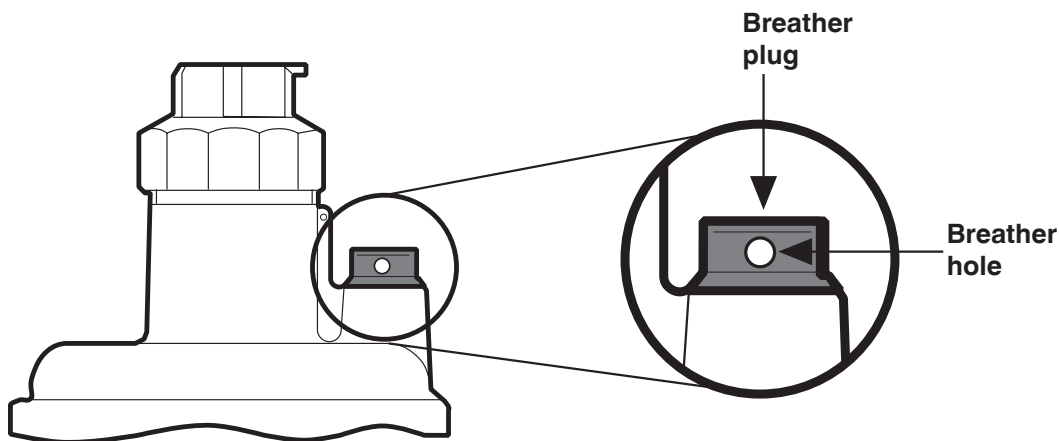

Vent Limiting Device & Vent Line Connection

Vent Limiting Device

The FRS/6 series regulator contains an internal, factory installed vent limiting device, which limits the escape of gas to less than 0.5 CFH @ 5 PSI in case atmospheric diaphragm ruptures. Venting required unless accepted by the authority having jurisdiction.

Vent Line Requirements

- Follow the local code for vent sizing and termination requirements. In the absence of local codes, follow National Fuel Gas Code NFPA 54, the International Fuel Gas Code or the CSA B149.1 installation code for venting requirements.
 - Terminate the vent to an approved location.
 - At the point of termination, the vent line must be protected from insects and water intrusion. It is highly recommend to install an insect screen and terminate the pipe with the exit facing downwards to prevent rain water from entering.
- NOTE:** For appliances using direct spark ignition, DUNGS recommends using the FRS's factory installed, internal vent limiting device rather than installing a vent line. Vent lines can cause resistance or even feedback pressures that increase the look-up pressure, potentially leading to hard light-offs or even damaging the appliance.

Installation Procedure

- If venting the regulator, the vent line is to be connected to the upper dome of the FRS regulator as illustrated.
- Remove the beather plug.
- On indoor installations requiring venting outdoors, run the piping as short and as direct as possible.
- The vent connector is G 1/4 for FRS 705/6 to FRS 710/6 and G 1/2 for FRS 712/6 to FRS 730/6 and for all ISO flanged regulators. G 1/4 to 1/4" NPT adapters are available: (part number 231-944) and G 1/2 to 1/2 NPT (part number 231-945).

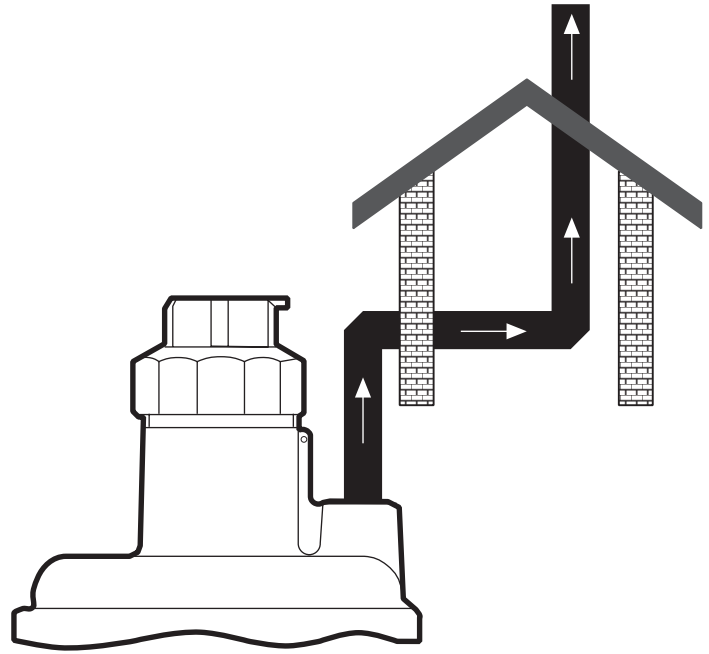

In the absence of venting codes and where venting is required, each regulator must be vented separately from all other vents.

External Impulse

- When it is desirable to use the external impulse as the feedback for the regulator, the internal impulse must be plugged. Seal the internal impulse connection with a silicone or RTV sealant suitable for exposure to natural gas, propane, or butane.
- The external impulse must be properly terminated and made of a durable, metal material that is suitable for gas service.

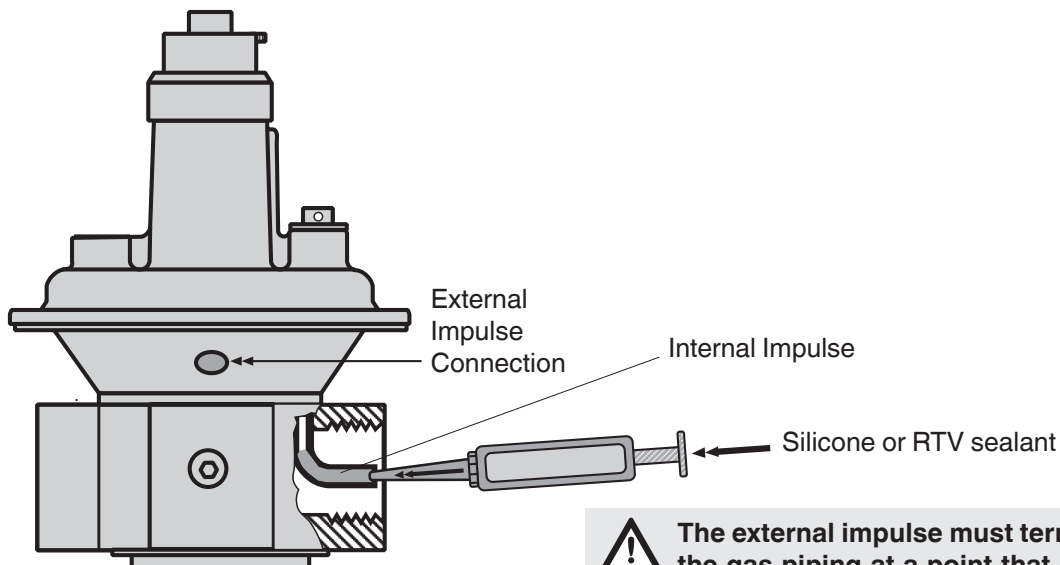

The external impulse must terminate back into the gas piping at a point that is upstream two safety shutoff valves in series.

Outlet Pressure Adjustment

Adjusting the FRS outlet pressure

1. Verify that the intended output pressure is within the spring range that is installed in the regulator by comparing the colored outlet pressure label with the table on page 6.
2. Remove the black cover.
3. To increase outlet pressure, turn the adjustment spindle clockwise. To decrease the outlet pressure, turn the adjustment spindle counterclockwise.
4. Always use an accurate pressure gauge connected downstream of the regulator to measure the actual outlet pressure as the FRS is mounted in the operating position.
5. Reinstall the black adjustment cover.
6. To prevent unauthorized adjustment, holes in the black cover and the side of the regulator can be used to secure a lead seal.

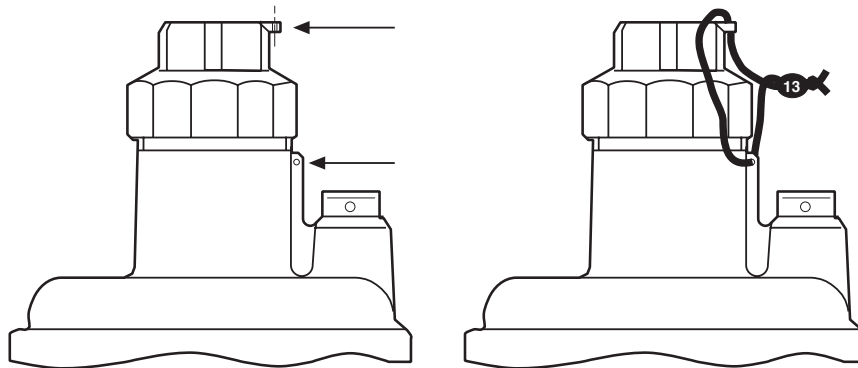
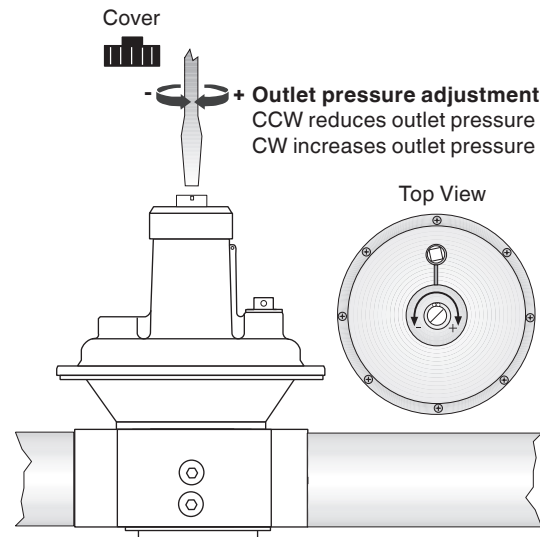

Spring Replacement

Spring Replacement

- Remove the adjustment cover.
- Completely release the spring tension by turning the adjustment spindle completely counterclockwise with a screwdriver, and remove the aluminum cap.
- Remove existing spring and insert new spring.
- Re-install the adjustment cover, and apply the new outlet pressure label provided with new outlet pressure range onto the name plate.
- Reinstall the adjustment cover.



Never have your head above or near the aluminum cap when removing regulator spring. The spring tension can be high enough to rapidly eject the aluminum cap with a large force.

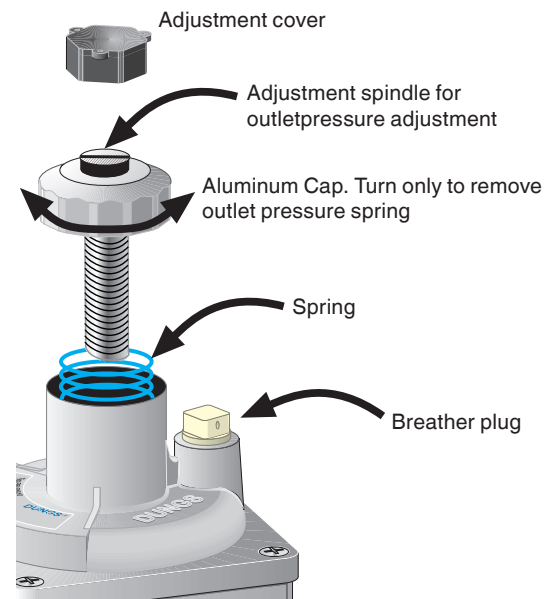

Flow Curve

Flow Curve (mechanically open) Using Natural Gas.

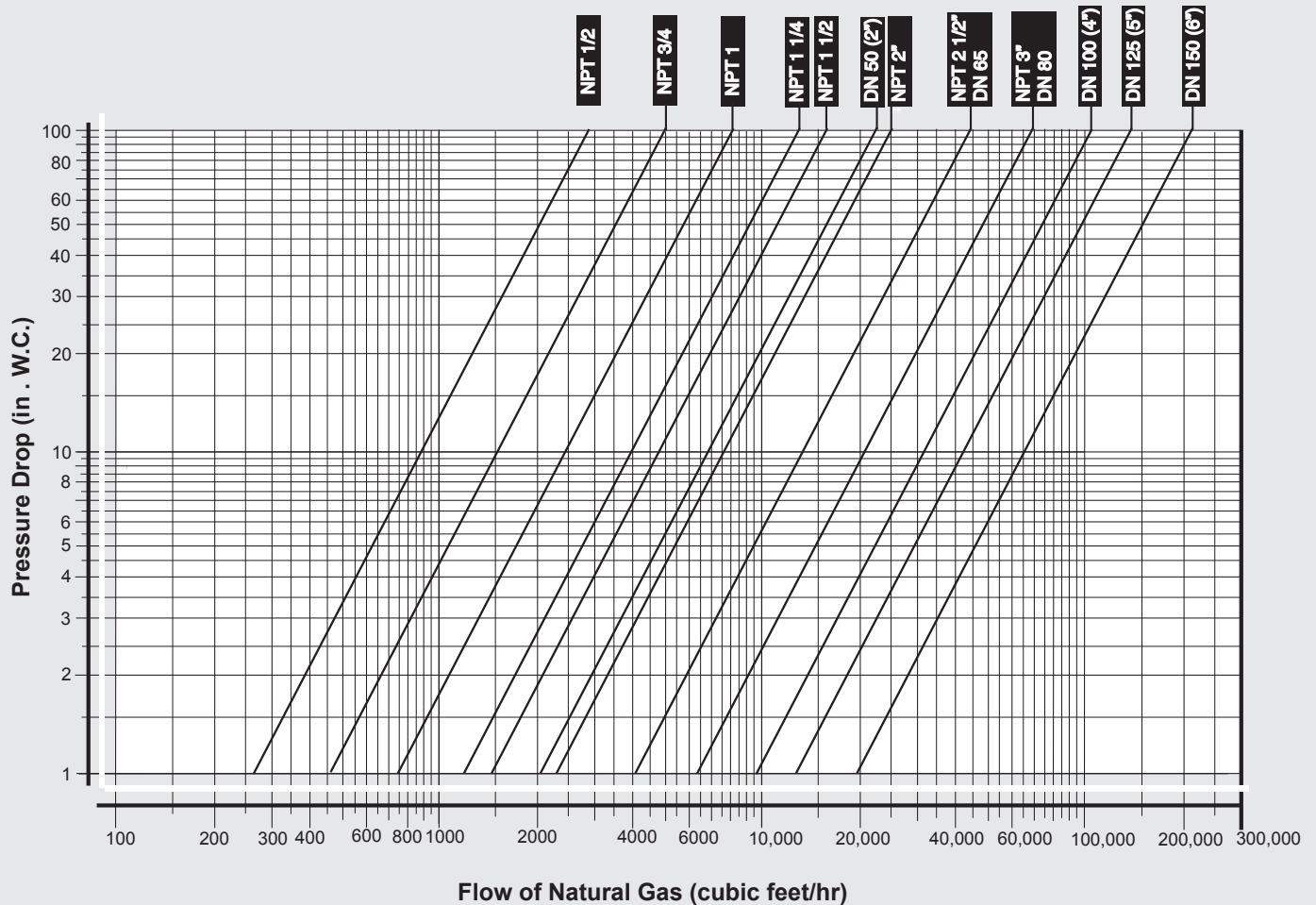

Sizing an FRS for an application

- 1) Based on desired maximum flow rate, intersect the FRS flow curve and determine corresponding pressure drop.
- 2) Select a spring in the table on page 6 that fits within the desired outlet pressure for the application.
- 3) Add the desired outlet pressure to the pressure drop determined in step one above. The sum of these is the required minimum inlet pressure to achieve the desired maximum flow rate.

Example of sizing an FRS for an application

- 1) Desired maximum flow rate = 2,000 CHF and desired outlet pressure = 12"WC
- 2) From table on page 6, either the blue, red or yellow spring will work, because 12" of W.C. is within the range of these springs.
- 3) 2000 CFH intersects the following curves and corresponding flow rates
 - FRS 707 = 16" of W.C. drop
 - FRS 710 = 6.5" of W.C. drop
 - FRS 712 = 2.7" of W.C. drop
 - FRS 715 = 1.8" of W.C. drop
 Adding 12" to these values gives the following minimum inlet pressures required to achieve the flow rate up to 2000 CFH with 12" of W.C. outlet pressure.
 - FRS 707 requires minimum inlet pressure of 28" (16" + 12") of W.C.
 - FRS 710 requires minimum inlet pressure of 18.5" (6.5" + 12") of W.C.
 - FRS 712 requires minimum inlet pressure of 14.7" (2.7" + 12") of W.C.
 - FRS 715 requires minimum inlet pressure of 13.8" (1.8" + 12") of W.C.

Accessories & Replacement

FRS Flange Accessories

Body Size	Flange Description	# of Holes per Flange	Flange Order No.	Bolt size	**Bolt Order No.	***Gasket Order No.
FRS 5040	1 1/2" ISO Flanged	4	227-137	M16x55	135-940	50157
FRS 5050	2" ISO Flanged	4	227-138	M16x65	135-930	50158
FRS 5065	2 1/2" ISO Flanged	4	227-139	M16x65	135-930	50158
FRS 5065	2 1/2" ISO to NPT	4	243-690	M16x65	135-930	50158
FRS 5080	3" ISO Flanged	8	227-140	M16x65	135-930	50160
FRS 5080	3" ISO to NPT	8	243-219	M16x65	135-930	50160
FRS 5100	4" ISO Flanged	8	227-141	M16x65	135-930	50161
FRS 5125	5" ISO Flanged	8	227-142	M16x75	148-830	50162
FRS 5150	6" ISO Flanged	8	227-143	M20x80	135-950	030-403

* When a control is used alone, one mating flange is needed for each end, for a total of two flanges. When one control is bolted to another, such as an FRS to a DMV dual modular safety valve, one mating flange is needed for each end, for a total of two flanges.

** Includes one bolt, one lock washer, and one nut.

*** One seal needed for each flange.

Repair Kits

Repair Kit (contains all internal hardware to rebuild regulator)	Part #
FRS 705/6	Not available
FRS 707/6	Not available
FRS 710/6	Not available
FRS 712/6, 715/6 & 5040	068-924
FRS 720/6 & 5050	068-932

Repair Kit (contains all internal hardware to rebuild regulator)	Part #
FRS 725/6 & 5065	068-940
FRS 5080 & 730/6	091-868
FRS 5100	091-876
FRS 5125	069-005
FRS 5150	069-013

CSA Range of Regulation (Flow Rates in CFH Natural Gas)

Spring color	Outlet Pressure Range	FRS 705/6 1/2 x 1/2	FRS 707/6 3/4 x 3/4	FRS 710/6 1 x 1	FRS 712/6 1 1/4 x 1 1/4	FRS 715/6 1 1/2 x 1 1/2	FRS 720/6 2 x 2	FRS 725/6, FRS 730/6 2 1/2 x 3
White	2" - 5"	5 - 100	5 - 130	5 - 580	5 - 580	5 - 580	5 - 580	5 - 580
Orange	2.8" - 8"	5 - 200	5 - 220	5 - 1,500	5 - 1,500	5 - 1,500	5 - 1,500	5 - 1,500
Blue	4" - 12"	5 - 300	5 - 350	5 - 1,700	5 - 1,700	5 - 1,800	5 - 2,000	5 - 2,000
Red	10" - 22"	5 - 500	5 - 600	5 - 2,000	5 - 2,100	5 - 2,200	5 - 2,400	5 - 2,400
Yellow	12" - 28"	5 - 600	5 - 700	5 - 2,200	5 - 2,300	5 - 2,500	5 - 2,700	5 - 2,700
Black	24" - 44"	5 - 700	5 - 850	5 - 3,000	5 - 3,200	5 - 3,500	5 - 3,700	5 - 3,700
Pink	40" - 60"	5 - 800	5 - 1,000	5 - 4,000	5 - 4,100	5 - 4,300	5 - 4,700	5 - 4,700

We reserve the right to make modifications in the course of technical development.



Karl Dungs, Inc.
 3890 Pheasant Ridge Drive NE
 Suite 150
 Blaine, MN 55449, U.S.A.
 Phone 763 582-1700
 Fax 763 582-1799
 e-mail info@karldungsusa.com
 Internet <http://www.dungs.com/usa/>

Karl Dungs GmbH & Co. KG
 P.O. Box 12 29
 D-73602 Schorndorf, Germany
 Phone +49 (0)7181-804-0
 Fax +49 (0)7181-804-166
 e-mail info@dungs.com
 Internet <http://www.dungs.com>