

DF | Digital Freezestat



The DF is a digital freezestat that senses the temperature in an air make-up system and shuts down the system if the preset temperature is not reached within a specified time.

FEATURES

- 10K ohm thermistor probe in 10- and 20-foot lengths.
- Operates at 24 VAC, 50/60 Hz. or 115 VAC, 50/60 Hz.
- Open-board construction with conformal coating.
- Complies with UL 873.

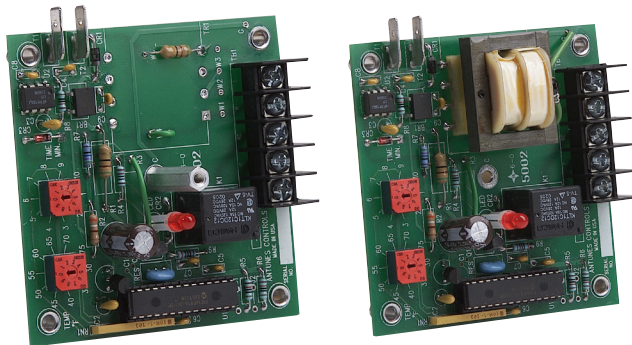

Dimensions

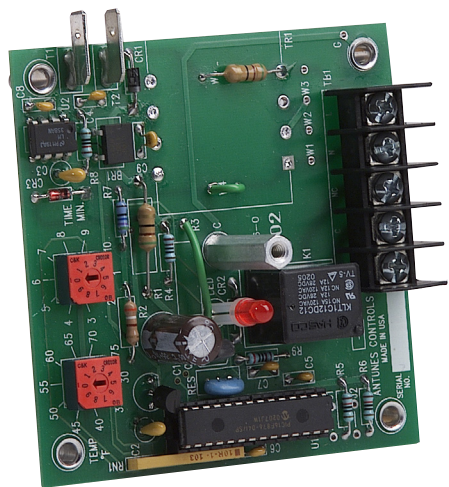

3" x 3" open board construction with stand offs.
Optional cover is shown.

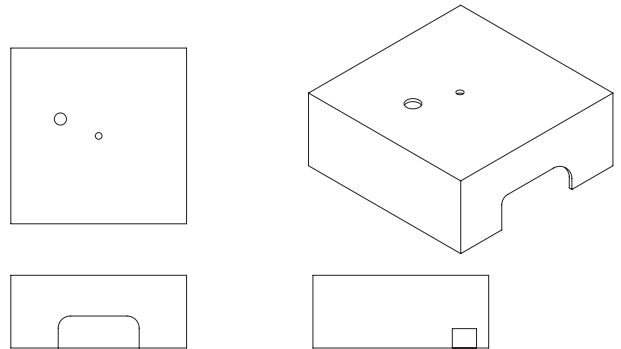

Specifications

- Sensor:** 10K thermistor probe, 10- or 20-foot lengths with bolt-down eyelet sensor.
- Input Power:** 24 VAC, 50/60 Hz. or 115 VAC, 50/60 Hz.
- Adjustable Digital Inputs:** Time: 1-10 minutes in 1 min. steps - Temperature: 30°F-75°F in 5° increments.
- Outputs:** Output drive for Freezestat relay K2 and associated LED2. Relay is normally de-energized—if the preset temperature is not reached within the preset time the relay will latch (energized) thereby opening the normally closed contact and turning off the externally controlled device. Only removing and reapplying power will reset the circuit and start the time period over again.
- Relay:** S.P.D.T., 8 amps, dry contact output, 1/4" spade terminal connection.
- Shipping Weight:** 1 lb. (.45 kg) without cover
2 lbs. (.9 kg) with cover

Limitation of Liability. If it is understood and agreed that seller's liability whether in contract, in tort, under any warranty, in negligence or otherwise, shall not exceed the return of the amount of the purchase price paid by purchaser and under no circumstances shall seller be liable for special, indirect or consequential damages. The price stated for the equipment is a consideration in limiting seller's liability. No action, regardless of form, arising out of the transactions may be brought by purchaser more than one year after the cause of action has accrued.