

PRECAUTIONS

- Do not switch pressure range and output mode when power is on. Make sure to power off the unit first, then set the DIP Switches to the correct positions and then power on the transmitter.

GENERAL INFORMATION

The DPT Series is based on a piezoresistive, silicon sensing element which senses Differential Pressure and provides an analog output. Field selectable analog outputs include 0-5 and 0-10 VDC, or 4-20 mA which correlate to a uni or bi-directional pressure range from 0-0.1" up to 0-40" of water column, depending on your model selection. Each unit has up to 8 field selectable, uni or bi-directional ranges (see Figure 6 p. 3).

MEDIA

The DPT can be used to monitor the differential pressure in any application that uses dry air or inert gas.

Mounting

Find a suitable location for the enclosure. The DPT has 2 two mounting holes located on the top and bottom flanges. Drill pilot holes for the (2) #8 x 3/4 self-drilling screws (supplied). Use the enclosure flange as a guide, or use the dimensions listed in **Figure 1**. Mount the unit vertically with the brass fittings pointing towards the ground. This ensures that any condensation that may form in the tubing does not have an effect on the pressure sensor. If mounting the unit horizontally, a slight zero shift may occur and care must be taken to prevent moisture from building up in the sensor.

FIGURE 1: DPT DIMENSIONS

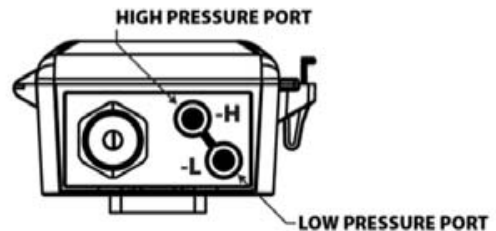
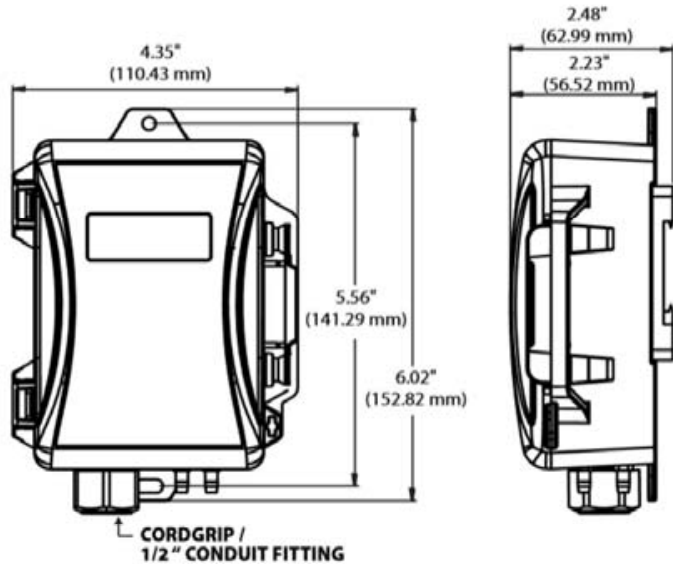
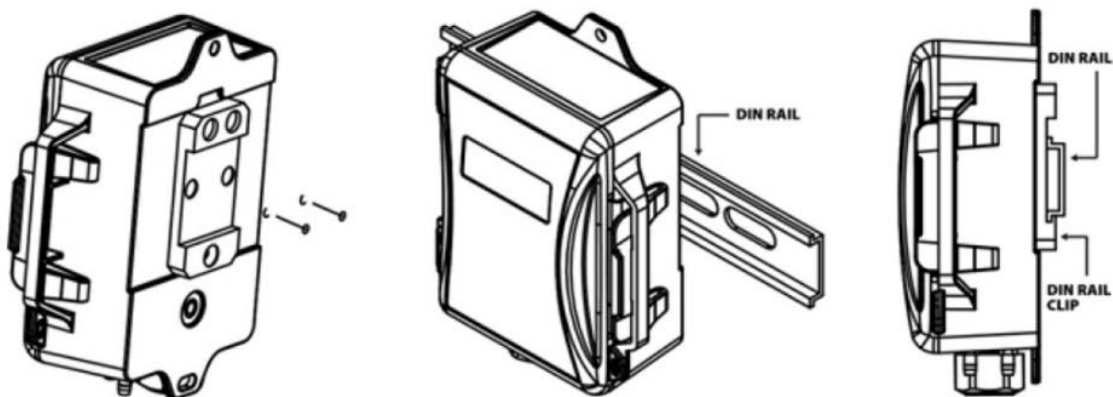

FIGURE 2: DIN RAIL MOUNTING



DIN RAIL MOUNTING *(Optional)*

Attach the DIN Rail Mounting accessory to the back of the enclosure using the two screws provided. To mount the sensor on the DIN Rail, place the bottom of the DIN Rail Clip into the 35mm DIN Rail and push the unit upward to engage the spring clip. Now press the top of the unit back until it locks into place - see **FIGURE 2** (p.1).

PITOT TUBE INSTALLATION

(Optional)

Slip the rubber washer over the threaded end of the pitot tube, keeping the washer as close to the threaded end as possible. Fasten the pitot into the threaded insert on the back of the enclosure. Press the rubber washer against the enclosure - see **FIGURE 3**.

Tubing Setup When Pitot Tube is Installed

Units will be shipped with silicone tubing attached to the high and low pressure barb fittings. The silicone tubing will need to be removed from the High Pressure (H) barb fitting and secured onto the pitot tube barb fitting. This will leave the high pressure barb fitting open to atmosphere, and the Low pressure barb fitting remaining at default setup.

Pressure Connections

The recommended connection tubing is $\frac{1}{4}$ " O.D push-on tubing (1/8" to 3/16" I.D.). For best results, all tubing lengths should be limited to a maximum length of 75 feet (23 meters). Longer runs will affect the response time.

FIGURE 3: PITOT TUBE INSTALLATION

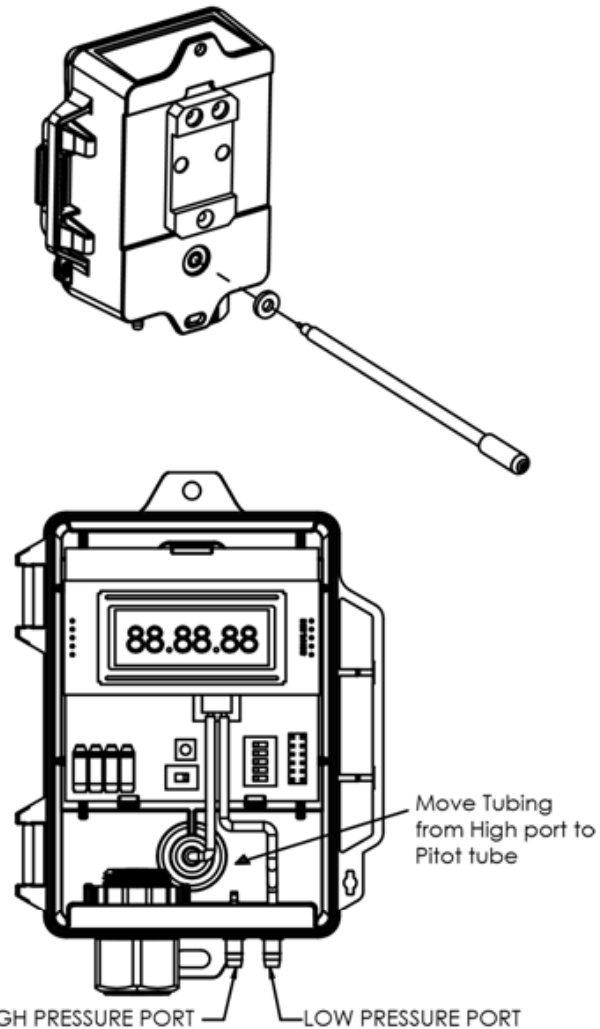

FIGURE 4: DUCT STATIC INSTALLATION

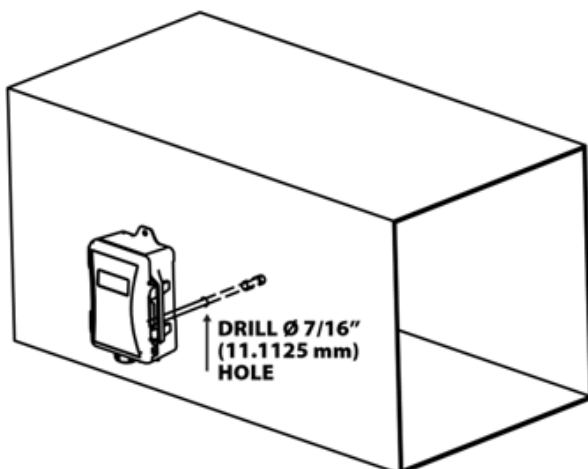
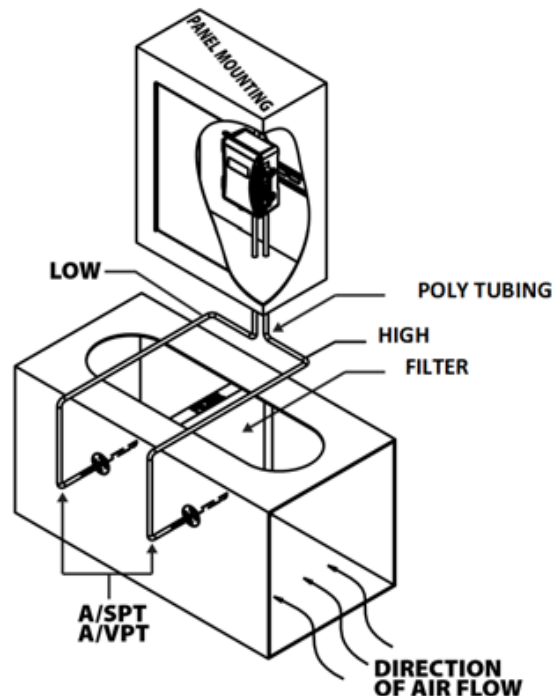

FIGURE 5: MEASURING DIFFERENTIAL PRESSURE ACROSS FILTER



WIRING

PRECAUTIONS

- Remove power before wiring. Never connect or disconnect wiring with power applied.
- When using a shielded cable, ground the shield only at the controller end. Grounding both ends can cause a ground loop.
- It is recommended you use an isolated UL-listed class 2 transformer when powering the unit with 24 VAC. Failure to wire the devices with the correct polarity when sharing transformers may result in damage to any device powered by the shared transformer.

- If the 24 VDC or 24VAC power is shared with devices that have coils such as relays, solenoids, or other inductors, each coil must have an MOV, DC/AC Transorb, Transient Voltage Suppressor or diode placed across the coil or inductor. The cathode, or banded side of the DC Transorb or diode, connects to the positive side of the power supply. Without these snubbers, coils produce very large voltage spikes when de-energizing that can cause malfunction or destruction of electronic circuits.

FIGURE 6: SW1 and SW3 OUTPUT SWITCHES

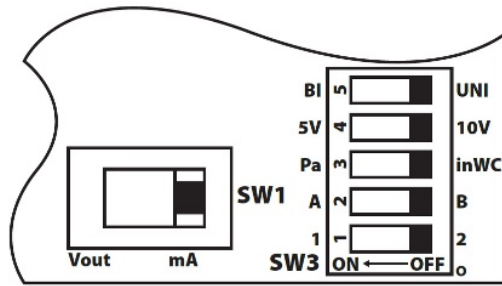

TABLE 1: WIRING CONNECTIONS

OUTPUT SIGNAL	OUTPUT MODE (SW1)	OUTPUT SIGNAL (SW3 Position 4)	SUPPLY VOLTAGE	WIRE CONNECTIONS			
				RED	BLACK	WHITE	YELLOW
0-5 VDC	Vout	5 V	VAC/VDC	V+	COM	VOUT	N/C
0-10 VDC	Vout	10 V	VAC/VDC	V+	COM	VOUT	N/C
4-20 mA	mA	N/A	VDC	V+	N/C	N/C	IOUT
4-20 mA	mA	N/A	VAC	V+	COM	N/C	IOUT

N/A= Not Applicable
N/C= No Connection

FIGURE 7: Wiring Connections

2-Wire, 4-20 mA

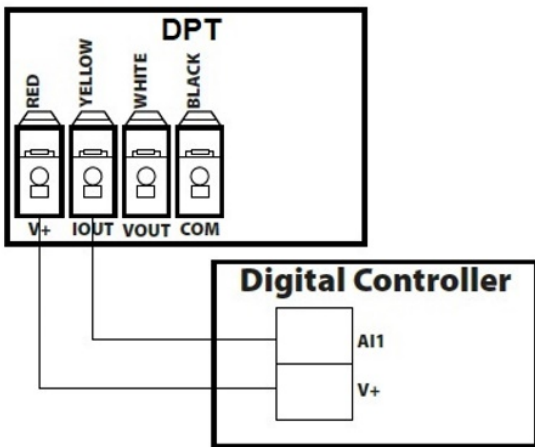

3-Wire, 0-5 V / 0-10 V

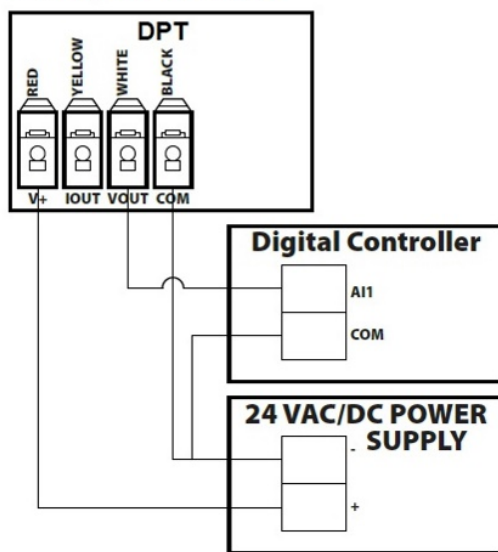

Open the cover of the enclosure. We recommend 16 to 26 AWG twisted pair wires or shielded cable for all transmitters. Twisted pair may be used for 2-wire current output transmitters or 3-wire for voltage output. Connect the wires to the unit's finger push-button terminal blocks. Each DPT unit can be configured to three output signals: 4-20 mA, 0-5 V or 0-10 V. Use the Wiring Connections and diagrams to determine the proper wiring for your application. See **TABLE 1** (p.3) for Output Mode and Output Signal switch positions.

Note: When using 1/2" conduit, the strain relief fitting must be removed from the enclosure.

Note: Make sure that any conduit or metal fittings do not come in contact with the circuit board.

TABLE 2: STANDARD MODEL NUMBERS

OUTPUT SIGNAL	DESCRIPTION
DPT-S-1	0-0.1", 0.2", 0.5", 1", Without Display
DPT-S-2	0-1", 2", 5", 10", Without Display
DPT-S-3	0-10", 20", 30", 40", Without Display
DPT-S-1-A	0-0.1", 0.2", 0.5", 1", Without Display, With Pitot Tube and DIN Rail Clip
DPT-S-2-A	0-1", 2", 5", 10", Without Display, With Pitot Tube and DIN Rail Clip
DPT-S-3-A	0-10", 20", 30", 40", Without Display, With Pitot Tube and DIN Rail Clip
DPT-S-1-D	0-0.1", 0.2", 0.5", 1", With Display
DPT-S-2-D	0-1", 2", 5", 10", With Display
DPT-S-3-D	0-10", 20", 30", 40", With Display
DPT-S-1-D-A	0-0.1", 0.2", 0.5", 1", With Display, Pitot Tube, and DIN Rail Clip
DPT-S-2-D-A	0-1", 2", 5", 10", With Display, Pitot Tube, and DIN Rail Clip
DPT-S-3-D-A	0-10", 20", 30", 40", With Display, Pitot Tube, and DIN Rail Clip

ZERO FUNCTION

The DPT unit should be "ZEROED" before pressure is applied to the unit. The zero button is used to cancel out any offsets caused by installation and sensor drift. The Zero adjustment must be performed with NO pressure applied to either side of the sensor.

Remove the tubing connected to the H(High) and/or L(Low) pressure fittings. Push "ZERO" button for more than three seconds before installation or whenever necessary.

For units with LCD display, "AUTOZERO" icon will be on when the unit enters zero mode. If zeroing process is successful, the "AUTOZERO" icon will flash twice.

FIGURE 8: AUTO ZERO BUTON - SW2

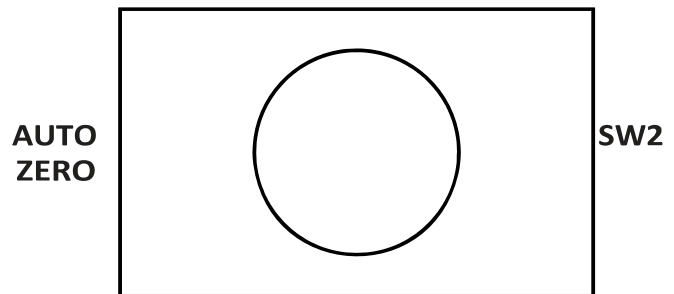

PRESSURE RANGE SELECTION

If a custom calibrated pressure range is ordered, DO NOT change the Pressure Range Selection DIP switch settings. **Table 2** lists the 12 standard model #'s.

MODE

The DPT can operate in either unidirectional mode (0 – X inWC) or bidirectional mode (\pm X inWC). Each unit could have up to eight field selectable, uni or bidirectional ranges.

Part #	Maximum Pressure (inWC)
DPT-S-1	1
DPT-S-2	10
DPT-S-3	40

CAUTION

- See TABLE 3 for your DPT model’s maximum pressure.
- DO NOT switch pressure range or output mode when POWER is ON. Make sure POWER to the unit is OFF. Failure to do so WILL NOT ALLOW any new switch settings to take place.
- Choose differential pressure range based on the expected differential pressure in your application. Move switches to the correct positions and THEN POWER ON the transmitter.

FIGURE 9: SWITCH SETTINGS

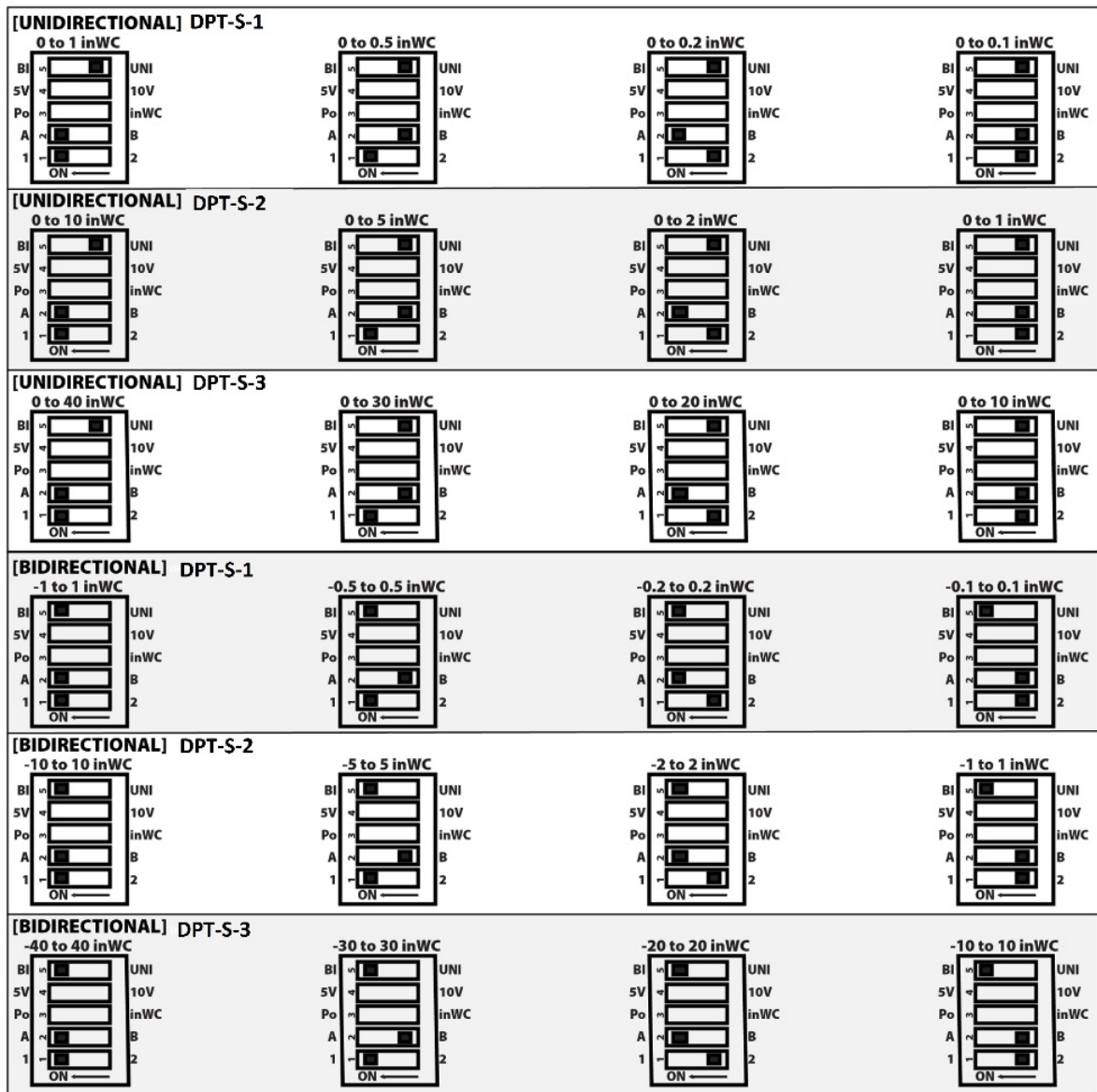

Unidirectional Mode

- DIP switch SW3 position five set at UNI side.
- DIP switch SW3 positions one and two are for Pressure Range Selection

Bidirectional Mode

- DIP switch SW3 position five set at BI side.
- DIP switch SW3 positions one and two are for Pressure Range Selection.

Note: In Bidirectional mode, a value of 0 inWC will have an output equal to 50% of the output signal range (12mA, 2.5V, 5V).

ADDITIONAL LCD FEATURES

LCD Engineering Units Adjustment

This option is ONLY for units with LCD display. Switch DIP switch SW3 position three to select Pa or inWC. If switched with power on, unit change will not take place until power is cycled.

“Out Of Range”

“OUT OF RANGE” icon will be on when differential pressure is over or under the minimum or maximum pressure range selected. If a DPT unit is outputting “OUT OF RANGE”, please turn off the unit immediately, and check the pressure input with a gauge or other test instrument. Once the pressure has been verified, set the Pressure Range Selection DIP switch to the proper positions based upon your maximum expected differential pressure.

CALIBRATION

DPT utilizes a digital pot for Span calibration and is factory set. There is no Span potentiometer for adjustment. In the event you require Span calibration, the unit must be sent back to the manufacturer.

The Offset can be adjusted using the Auto Zero function discussed on pg 4. Drift is a function of stress relaxation over time and this results in the offset shifting, and not the span . Periodically re-zeroing the device will eliminate the effect of drift.

PRODUCT SPECIFICATIONS

SPECIFICATIONS	
Supply Voltage:	4-20 mA Output: 16-36 VDC (250 Ω Load max.) / 22-36 VDC (500 Ω Load max.) 0-5 VDC / 0-10 VDC Output: 16-36 VDC / 24 VAC (+/- 10%)
Supply Current:	4-20 mA Output: 24 mA minimum 0-5 VDC / 0-10 VDC Output: 6 mA maximum
Output Signals:	Current Output: 4-20 mA, 2-Wire (Standard); (Current limited to 21.4 mA max) Voltage Signals: 0-5 VDC / 0-10 VDC, 3-Wire; Output limited @ 5.25 & 10.5 VDC
Response Time (0-100% FSO):	8 seconds
Output Update Rate:	1 second
Accuracy ¹ :	+/- 0.5% FSO; +/- 0.25% (Only for Specified Range)
Zero Function:	Pushbutton Zero Function
Thermal Effects ² :	+/- 0.067% FSO / °F (0.12% FSO / °C)
Proof Pressure / Burst Pressure ³ :	DPT-S-1: Proof: 270 inWC (67.2 kPa) Burst: 415 inWC (103.3 kPa) for 1 inWC (249.8 Pa) DPT-S-2: Proof: 350 inWC (87.12 kPa) Burst: 550 inWC (136.9 kPa) for 10 inWC (2490.8 Pa) DPT-S-3: Proof: 562 inWC (140 kPa) Burst: 1004.7 inWC (250 kPa) for 40 inWC (9963.6 Pa)
Operating Temperature Range:	-4 to 185 °F (-20 to 85 °C)
Compensated Temperature Range:	32 to 122 °F (0 to 50 °C)
Storage Temperature Range:	-22 to 185 °F (-30 to 85 °C)
Operating Humidity Range:	10 to 95% RH, non-condensing
Media Types:	Dry air or inert non-conductive gases
Enclosure Material / Flammability Rating:	Flame Retardant Polycarbonate; UL94-5VA
Wiring Connections:	Finger Pushbutton (Spring) Terminal Blocks; accepts 16-24 AWG wires
Conduit Knockouts:	Watertight Cordgrip Installed (1/2" NPT Conduit fittings accepted when Cordgrip removed)
Pressure Fitting Material:	Nickel Plated Brass or Stainless Steel
Tubing Size Accepted:	1/4" O.D. x 0.170" I.D. Poly Tubing

Note☒: Accuracy includes linearity, hysteresis & repeatability @ 71°F (21.5°C)

Note☒: Shift is relative to 71°F (21.5°C)

W.E.E.E. DIRECTIVE

At the end of their useful life the packaging and product should be disposed of via a suitable recycling centre. Do not dispose of with household waste. Do not burn.