

Model No. DFC-X

Support 877-351-4702

DIRECT FIRED DIGITAL TEMPERATURE CONTROL INSTALLATION, OPERATION, AND MAINTENANCE MANUAL

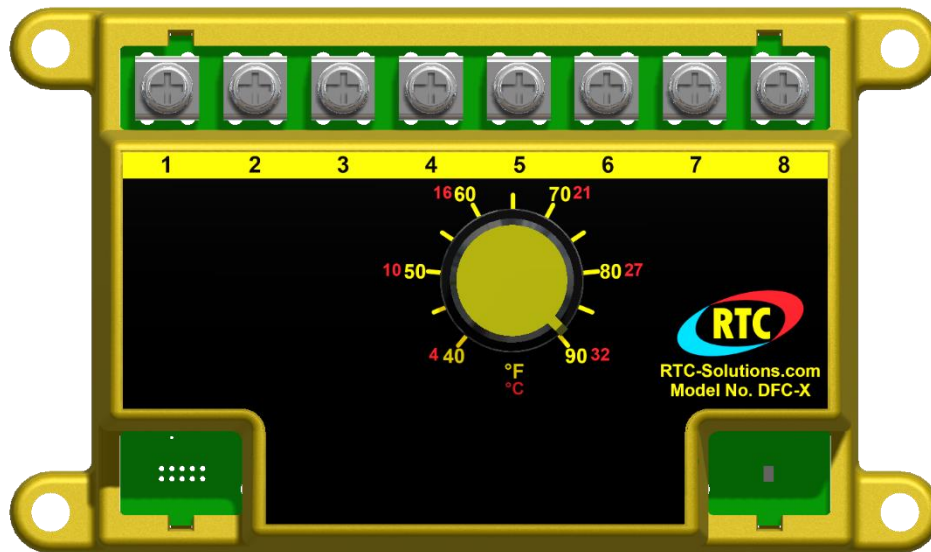

This manual covers the following products:

- DFC-X Direct fired control with integral 40-90°F (4-32°C) dial 0-24VDC output
- TS-01 Temperature sensor 40-250°F (4-121°C)
- DFTD Temperature dial 5 selectable ranges
- RDU Remote display unit
- DAT-12 Discharge air tube
- PWM-10V PWM to 10V output converter

Table of Contents

Overview.....	2
Specifications.....	2
Power Requirements.....	2
DFC-X Ambient Temperature Limits.....	2
TS-01/DFTD Ambient Temperature Limits.....	2
Accuracy.....	2
Installation.....	2
Wiring.....	2
Standard control with remote setpoint.....	2
Standard control with integral setpoint.....	3
Optional room space control.....	4
Optional multiple setpoint temperature control.....	5
Operation.....	5
Start up.....	5
Sequence of operation.....	5
Calibration.....	5
Troubleshooting.....	5
LED Code Chart.....	6
TS-01 and DFTD Resistance chart.....	6

Overview

The Roof Top Control Solutions direct fired digital temperature control is a microprocessor based control that utilizes an intelligent PID software algorithm to modulate gas flow to a burner in direct fired make up air applications. The closed loop system contains three components including the temperature sensor (TS-01), the direct fired control (DFC-X), and the direct fired temperature dial (DFTD) or the remote display unit (RDU). The DFC-X auto detects if there is a remote dial connected. When a remote is not connected, the DFC-X uses the internal setpoint. The system compares the discharge temperature of the heating unit to the set point dial 40 times per second insuring accurate and repeatable temperature control. The software provides smooth output control eliminating excessive swings observed with older analog systems. A 10 second start up delay is standard, and an onboard LED indicates simple diagnostics.

Specifications

Power Requirements	24VAC 50/60Hz 20VA isolated class II transformer
DFC Ambient Temperature Limits	
Storage	-40-140°F (-40-60°C)
Operating	-40-140°F (-40-60°C)
TS-01/DFTD Ambient Temperature Limits	
Storage	-40-250°F (-40-121°C)
Operating	-40-250°F (-40-121°C)
Accuracy	+/-3°F (1°C)

Installation

All control wiring should be shielded with the shielding grounded at one end only and/or the wiring should be run in separate conduit from any high voltage wires. Interference from these sources could cause control function errors or permanent damage. The DFC-X control should be mounted in a housing free from the elements of weather. Insulated fork terminals are recommended for best contact when attaching wiring to the provided screw terminals. The DFC-X can drive up to a .5 amp 24VDC direct acting solenoid.

The DFTD can be set to 5 different temperature ranges by moving jumper J1 as shown in Figure 1 on the back of the dial to the desired position. 5 different temperature overlays are available to match the range chosen.

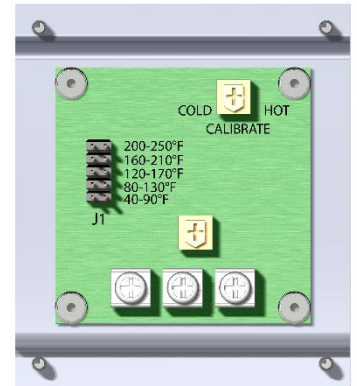
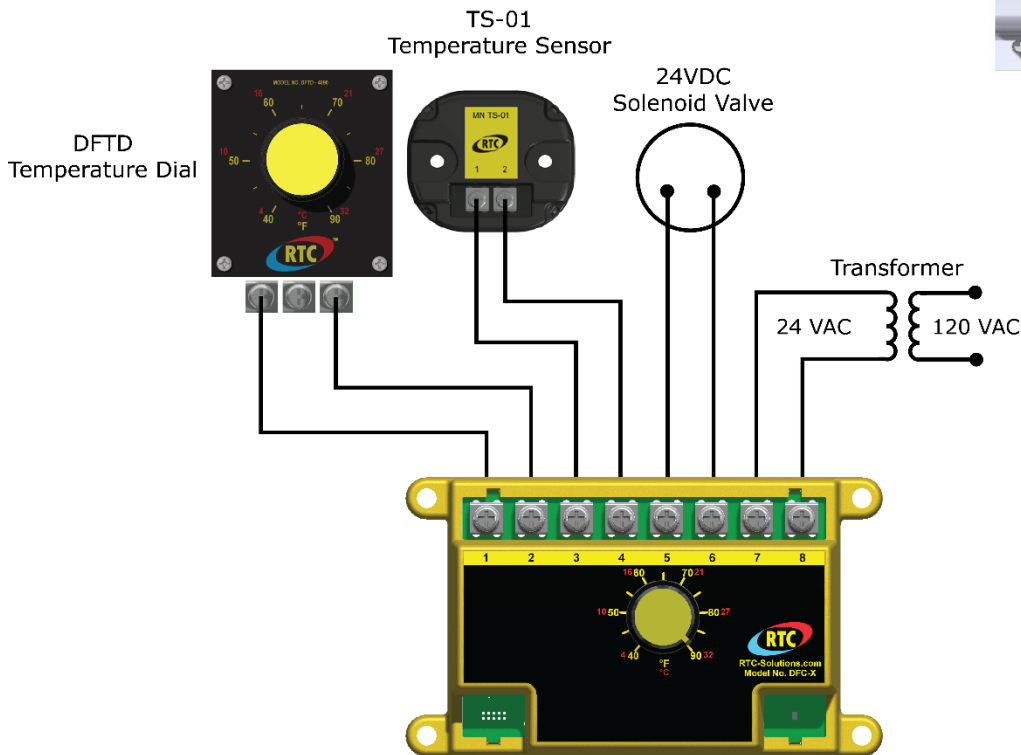

Figure 1: DFTD Backside

Wiring



Standard control with remote setpoint

Figure 2 - DFC-X wiring showing 24V DC output

PWM-10V

We do offer a PWM output converter to connect the DFC-X to a 0-10V actuator rather than a 24VDC solenoid valve. If you are utilizing the PWM-10V to connect to a motorized actuator or any other device with it's own power supply, than be sure the DFC-X has its own isolated transformer separate from the power source for the actuator, or the control may be damaged.

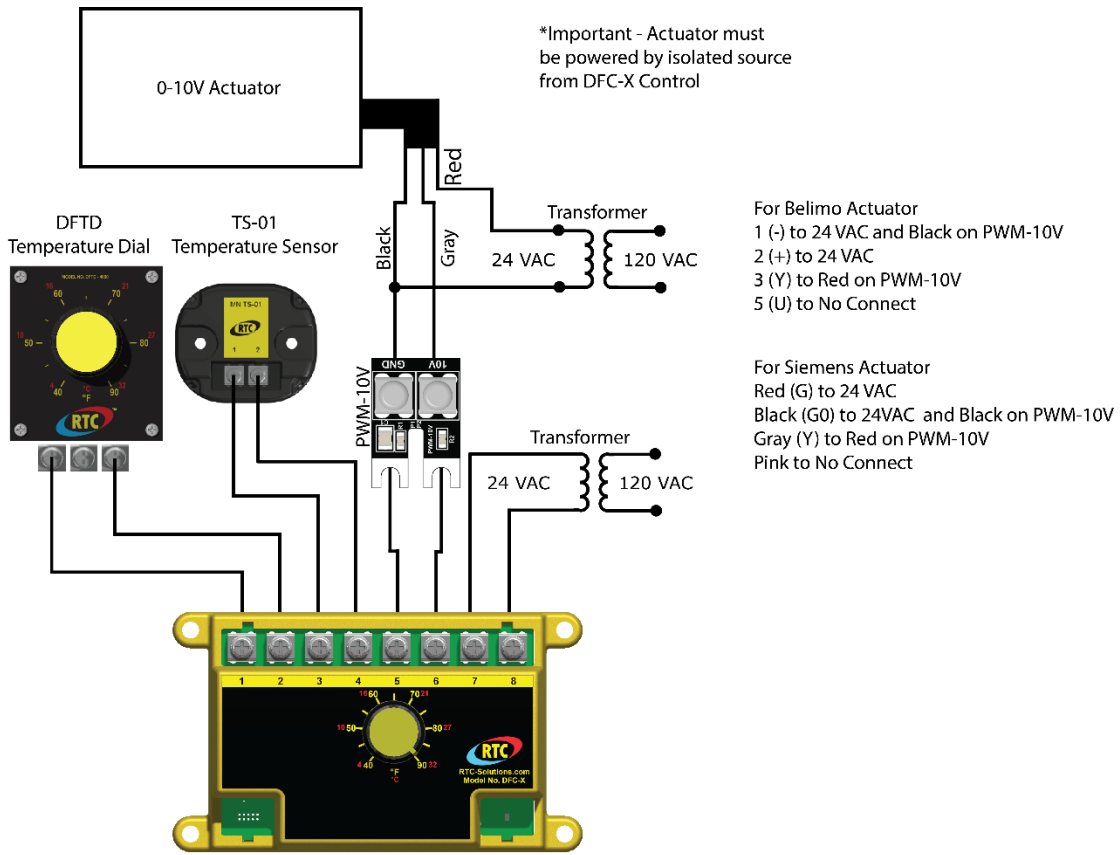

Figure 3 - DFC-X wiring showing 0-10V DC output

Standard control with integral setpoint

The DFC-X, when using the onboard selector, should only be paired with RTC's TS01(Temperature Sensor). Other resistive sensors can be used only when paired with a compatible dial.

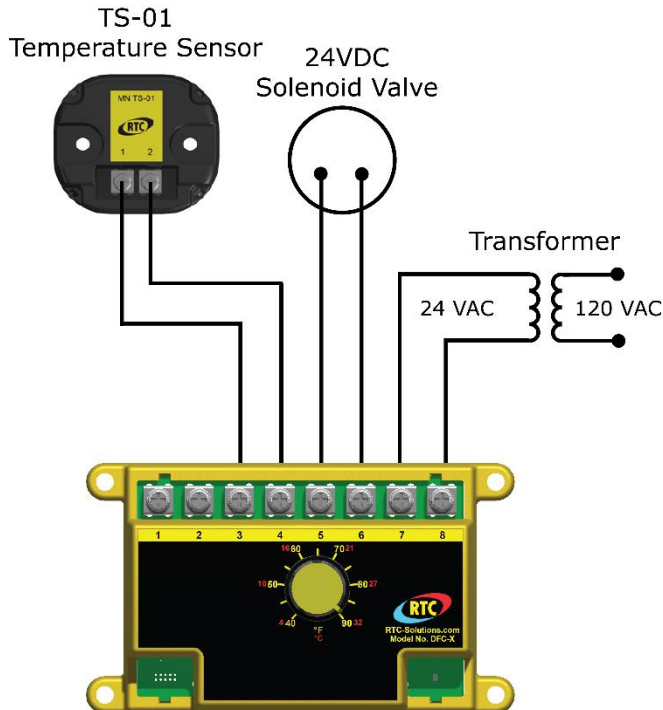

Figure 4 - DFC-X wiring showing 24V DC output

Optional room space control

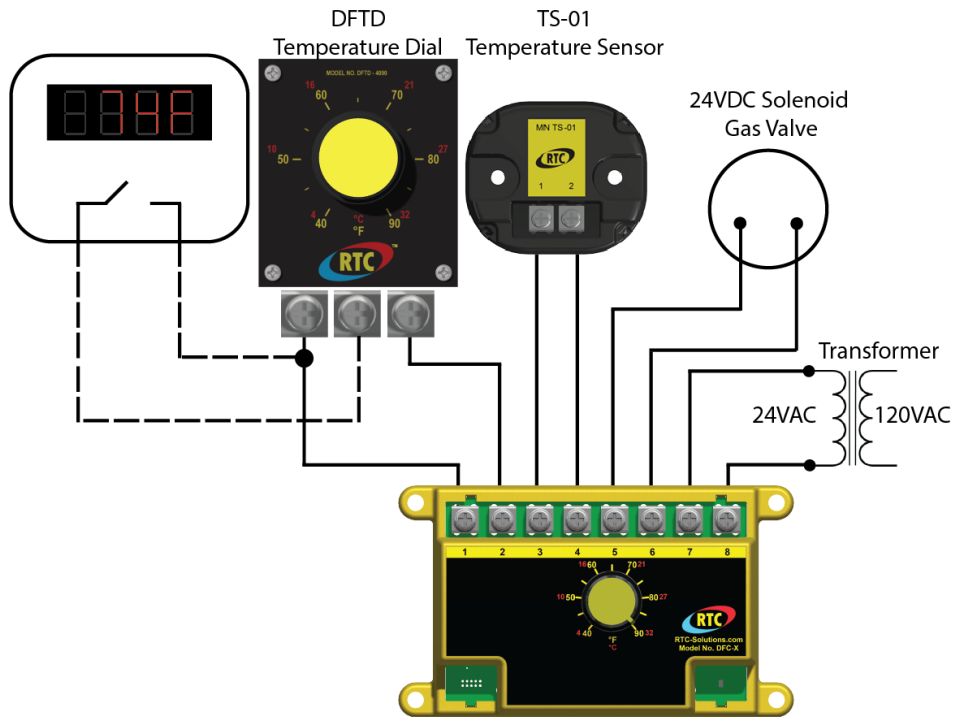

Figure 5 - Room space control with thermostat

A standard make or break thermostat with normally open contacts can be connected between terminals 1 and 2 as shown in Figure 5. When connected in this way the thermostat may be set for a desired room temperature for space control applications. When the room thermostat is satisfied, the discharge temperature will return to the temperature set on the dial on the front of the DFTD. With older models of the DFTD, there is a potentiometer (R1) on the back of the control that controls how much the temperature will increase by when the room thermostat calls for more heat. For proportional room space control, the DFC-X may be connected as shown in Figure 6. See RDU literature for details.

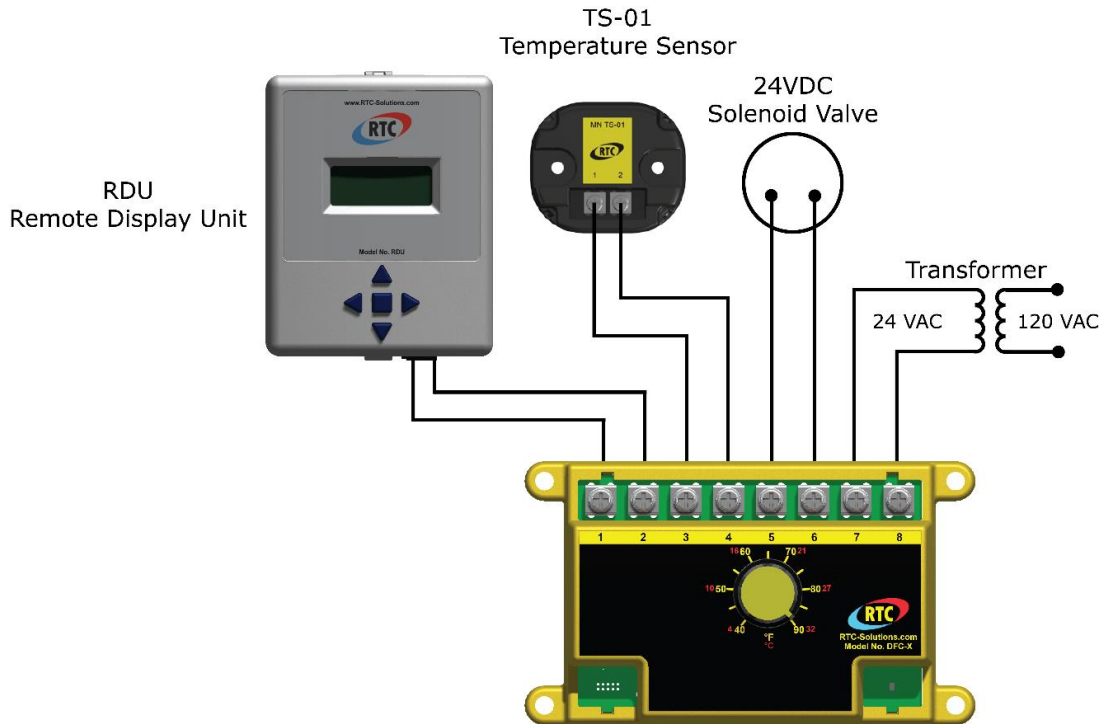

Figure 6 - Room space control with digital space control

Optional multiple setpoint temperature control

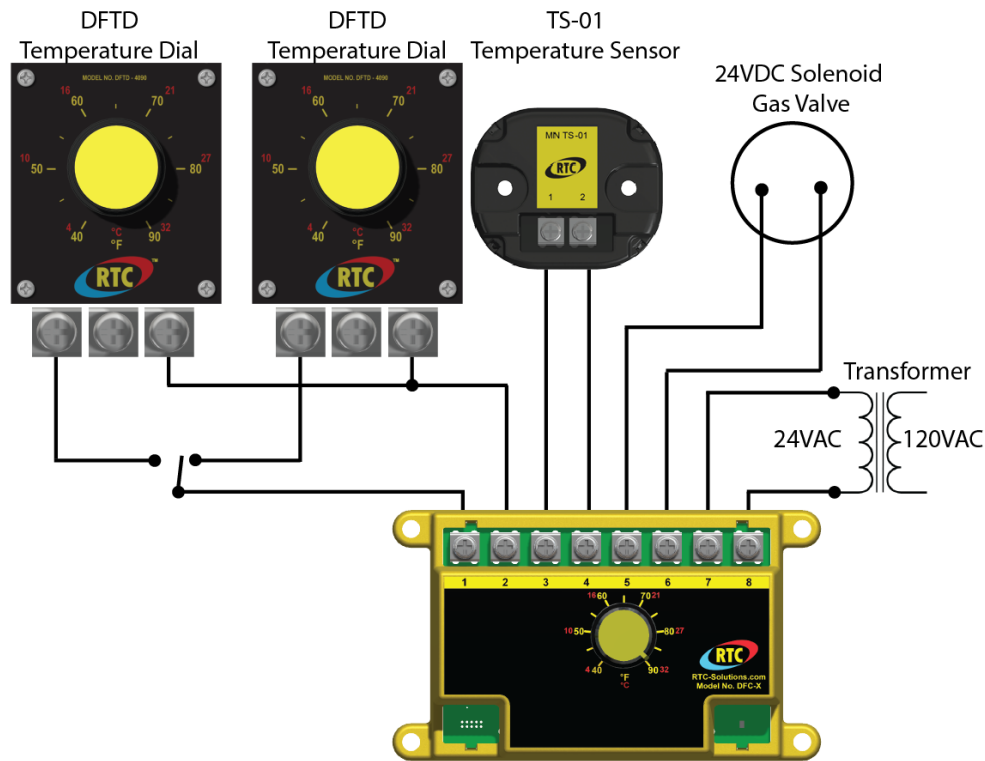

Figure 7 - Control with multiple set points

More than one temperature dial can be connected as shown in Figure 7 for applications such as paint spray booths or process control.

Operation

Start up

Setting low fire - The minimum firing rate may be set by removing the wire from the terminal number 6 on the DFC-X control. This disconnects the power to the control valve. Refer to the control valve manufacturer's literature for this adjustment. You can also set low fire by entering Maintenance Mode as described below.

Setting high fire - The maximum firing rate may be set by removing the wire from terminal number 4 on the DFC-X control. This disconnects the discharge air sensor and sets the output to the control valve to its maximum. While setting high fire, the LED will repeatedly blink red. Refer to the control valve manufacturer's literature for this adjustment. You can also set high fire by entering Maintenance Mode as described below.

Sequence of operation

Upon applying power to the DFC-X control the 10 second start up delay will begin indicated by a slow blinking green LED (about once every 2 seconds) on the face of the control. After the start up delay has completed, the LED will either repeatedly blink green twice or repeatedly blink green three times depending on whether you are using an external setpoint or the internal setpoint. When using the internal setpoint the control will repeatedly blink twice and when connected to an external setpoint it will repeatedly blink three times. At this time the control will begin modulating the output as required. Any system errors are indicated by various LED codes described in Figure 8 below.

Maintenance Mode

To enter maintenance mode short terminals 1 with 2 as well as 3 with 4. The LED will blink red and green repeatedly to indicate it is in maintenance mode. In this mode you can turn the knob on the front of the control to directly operate the valve. When turned all the way clockwise the valve would be fully open. Conversely, when turned all the way counter clockwise the valve would be closed. This mode can be used to set low fire and high fire. To set low fire, turn the knob counter clockwise and refer to the control valve manufacturer's literature for this adjustment. To set high fire, turn the knob clockwise and refer to the control valve manufacturer's literature for this adjustment.

Troubleshooting

The DFC-X control provides some diagnostics via the on board LED labeled "STATUS". A system fault is indicated by various LED codes described in Figure 8. They usually indicate that the sensor or dial are either disconnected or improperly wired. Check all connections per the included wiring diagrams. The fault also may be caused by a damaged sensor or dial. Both devices may be tested with an Ohmmeter by removing the wires from the

DFC control and measuring across the device. The devices should measure between 12.8K and 7K OHMS. If there is a fault light and the devices measure the proper resistance then the control may be damaged. If there is no fault light but the system is not modulating properly you may check the control output by repeating the start up procedure and measuring terminals 5 and 6 on the DFC-X as stated below.

LED Code	Meaning	Solution
Blinking Green	10 Second Startup Delay	N/A
Double Blinking Green	Internal Setpoint Operation	N/A
Triple Blinking Green	External Setpoint Operation	N/A
Blinking Red	Temperature Sensor Open	Remove wires 3 and 4 and measure resistance across the sensor. Compare to resistance chart.
Double Blinking Red	Temperature Sensor Short	Remove wires 3 and 4 and measure resistance across the sensor. Compare to resistance chart.
Triple Blinking Red	External Setpoint Short	Remove wires 1 and 2 and measure resistance across the dial. Compare to resistance chart.
Red/Green	Maintenance Mode	N/A
Double Red/ Double Green	Generic Error	Contact Support

Figure 8 - LED Code Chart

Measuring the Control Output

Remove the wire from terminal number 4 on the DFC control and measure the voltage across terminals 5 and 6 with a voltmeter. The meter should read from 20 to 24 Volts. If it does not, disconnect the wires from the valve and measure the output without the valve connected. If it reads 20 to 24 Volts, refer to the valve manufactures literature for troubleshooting the valve. If it does not the control may be damaged.

DFTS and DFTD Resistance chart

Temp °F	Temp °C	Sensor Resistance	Dial Resistance				
		40-250	40-90	80-130	120-170	160-210	200-250
40	4.4	11210	11250				
50	10.0	11020	11050				
60	15.6	10826	10850				
70	21.1	10630	10650				
80	26.7	10433	10450	10380			
90	32.2	10234	10250	10180			
100	37.8	10034		9980			
110	43.3	9830		9780			
120	48.9	9624		9580	9590		
130	54.4	9413		9380	9390		
140	60.0	9199			9190		
150	65.6	8983			8990		
160	71.1	8766			8790	8700	
170	76.7	8550			8590	8500	
180	82.2	8337				8300	
190	87.8	8130				8100	
200	93.3	7930				7900	8060
210	98.9	7740				7700	7860
220	104.4	7560					7660
230	110.0	7393					7460
240	115.6	7237					7260
250	121.1	7095					7060