

## TS-D/TS-DD/TS-S/TS-C/TS-DS/TS-DC/Series

---

### Deaerator, Surge, or Condensate Control Panel, or Combination Deaerator/Surge or Deaerator/Condensate Panel



---

### Description

A TS-... series control system manages lead/lag operation of an individual deaerator (DA), DA two separate feedwater manifolds, surge, condensate, or a combination DA/Surge, DA/Condensate tank with up to six pumps.

Each TS-... control system includes a preprogrammed 6" or 10" touchscreen, a programmable logic controller (PLC), and digital and analog signal inputs and outputs for monitoring and control.

Flexible communication interface options to the building management system (BMS) provide streamlined data collection and monitoring.

---

### Application

TS-... control systems are suited for deaerator, surge, condensate, or combination deaerator and surge/condensate tank systems, pump controls, and other feedwater or transfer pump systems with water level control applications.

## Features

- Control an individual deaerator, surge, condensate, or combination deaerator and surge/condensate tank, with the ability to manage a separate deaerator and a surge or condensate tank with one TS-... series control panel
- PLC based control with touchscreen HMI
- Hand-Off-Auto selection switches provide continuous operation in the events of PLC and touchscreen downtime
- Graphics for individual pumps and automatically configured overview screen
- Monitor pump operation via current switches with starter control and via VFD feedback with VFD control
- Lead or lag the pumps based on feedwater pressure setpoints
- Lead lag the feedwater pumps for two groups based on two pressure setpoints
- Lead or lag the pumps based on boiler header pressure, plus an offset setpoint
- Lead lag the pumps based on a transfer pressure to the Deaerators
- Rotate feedwater and transfer pumps based on real clock run time hours
- Start or stop the feedwater pumps based on boiler start signal
- Control condensate tank with pumps OFF to fill, and Pumps ON to transfer.
- Provide deaerator/surge tank warning, alarms, and status.

- Provide high or low feedwater or transfer water pressure alarms
- Provide a chemical pump On/Off output control
- Provide high and low water alarm from the RWF55 if float control not installed
- Provide an alarm output for external use
- Maintain feedwater and transfer pump manifold pressures
- Maintain deaerator/surge tank water levels and redundant emergency water level control.
- Monitor high, low and low/low water level switch status
- Monitor DA steam pressure and provide steam pressure control
- Control make-up water and transfer valves
- Control pumps ON/OFF via motor starters, or modulate with variable frequency drives (VFDs)
- Clear English text for alarms
- SCC Master Panel lead/lag system interface
- Modbus TCP/IP standard for BMS interface
- Optional BACnet, LonWorks, Johnson Controls N2, Modbus RTU, PROFINET, or PROFIBUS for communication to building management systems

## **Standard Components System- Dependent**

TS-... control systems include the following components:

- Preprogrammed 6" or 10" touchscreen
- Programmable logic controller (PLC)
- Up to 8 analog inputs (4-20mA or 0-10V)
- Up to 6 analog outputs (4-20mA or 0-10V)
- 4 RTD inputs (1000  $\Omega$ )
- Hand-Off-Auto pump control switches
- Main 120 VAC power disconnect
- Alarm horn
- 24 VDC power supply and branch circuit protection
- Control power ON/OFF switch
- Pumps control switch
- Alarm reset/silence push button
- Pump control relays
- Chemical feed relay
- External alarm output relay
- 40 VAC transformers for SKB/C/D water level actuators
- RWF55.50A9 loop controller for DA level control, backup DA level control, and/or surge tank level control, backup surge level control
- RWF55.50A9 loop controller for DA level control, and/or surge tank level control, and/or tank pressure control
- Building management communications to most building management systems
- Optional 3 phase control panel for starter control or VFD Control

## Specifications

		<b>6" Touchscreen</b>	<b>10" Touchscreen</b>	
Physical characteristics	Main power	120 VAC	120 VAC	
	Touchscreen power	24 VDC	24 VDC	
	Power consumption	≤ 294 W	≤ 294 W	
	Dry contacts	2 Amps	2 Amps	
Operating environment	Operating temperature	32 to 122 °F	32 to 131 °F	
		[0 to 50 °C]	[0 to 55 °C]	
	Humidity	Max. 80% with no condensation	Max. 85% with no condensation	
	NEMA rating	-Standard	NEMA 1	NEMA 1
		-Optional	NEMA 12/NEMA 4X	NEMA 12/NEMA 4X

## Product Part Numbers

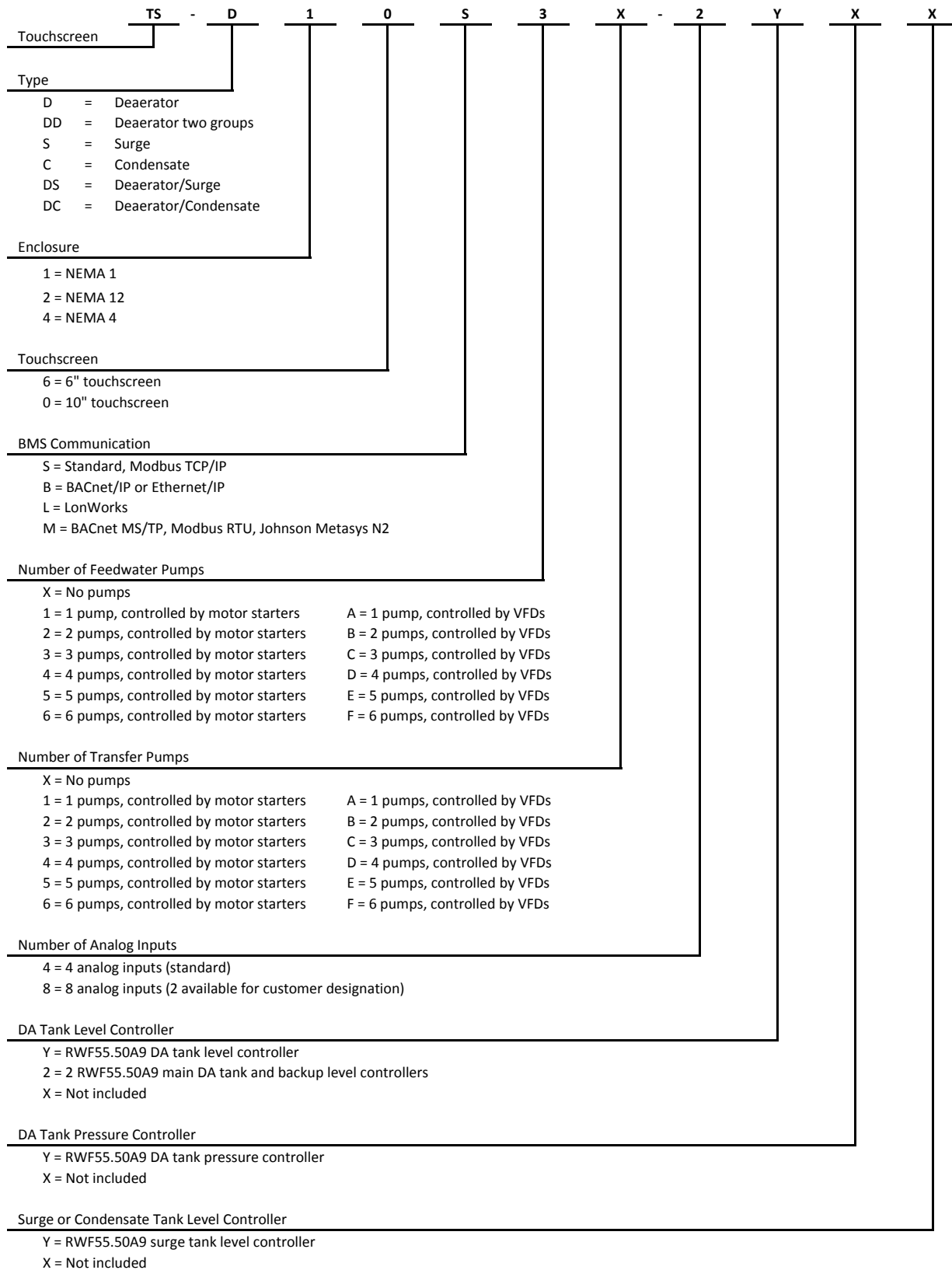

## Connections

(Connections are applicable based on the product part number selected)

**TS-D... series stand-alone DA tank with feedwater pumps, Up to 6 pumps for stand alone DA, or Up to 4 for group and 2 pumps group 2 if Two groups Da control selected**

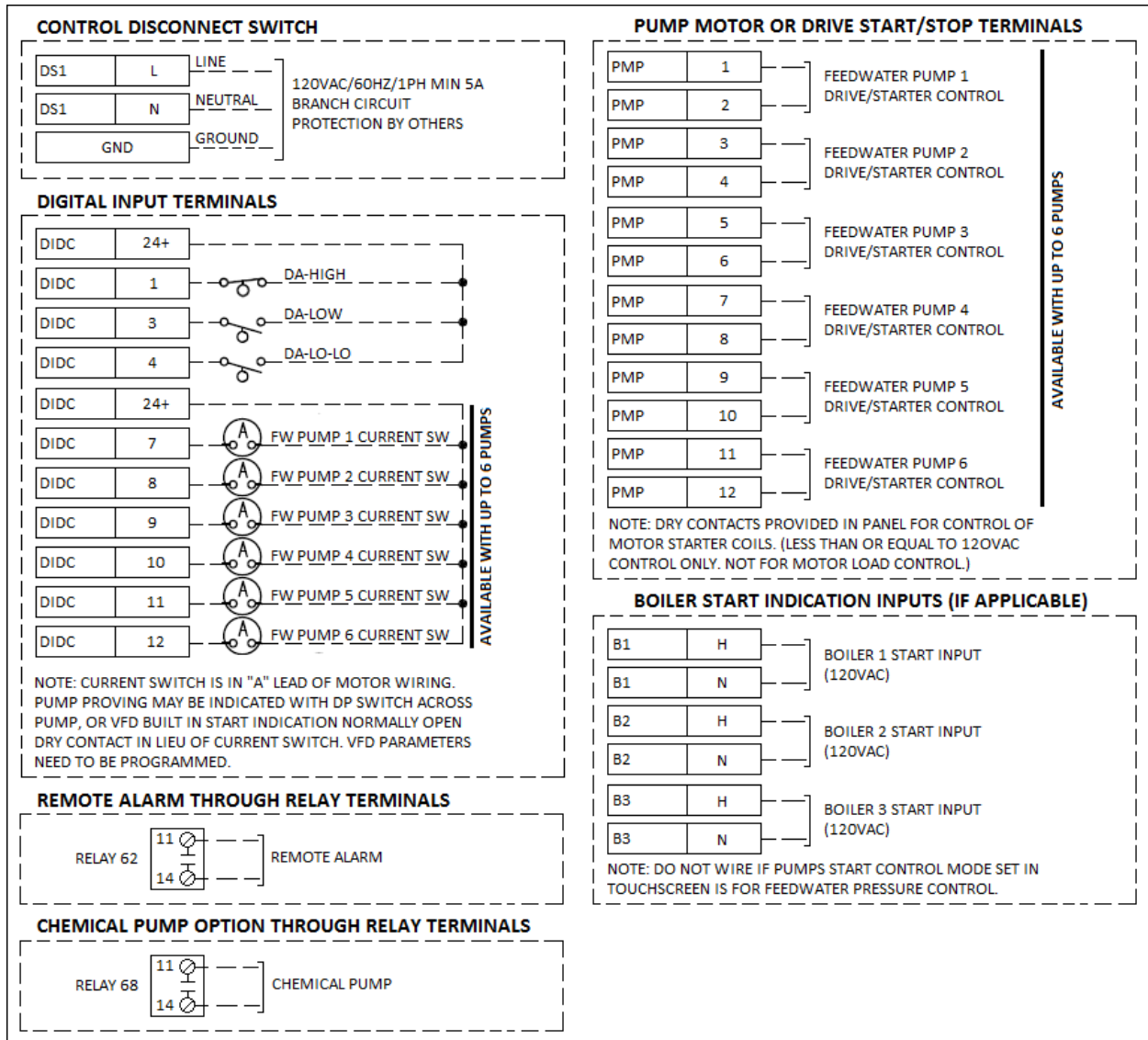

## Connections (continued)

### TS-D... series stand-alone DA tank with feedwater pumps (continued)

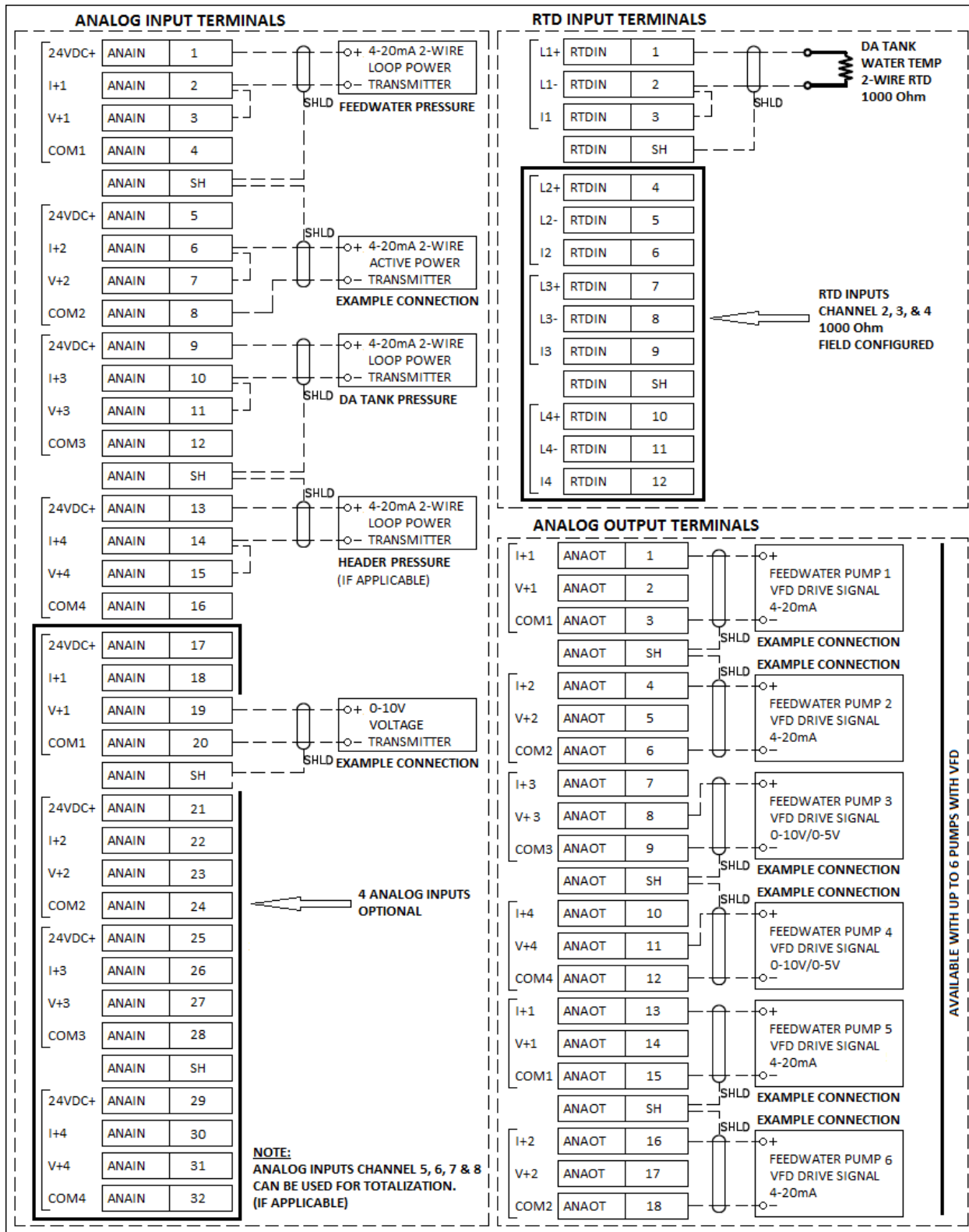



## Connections (continued)

### TS-D... series stand-alone DA tank with feedwater pumps (continued)

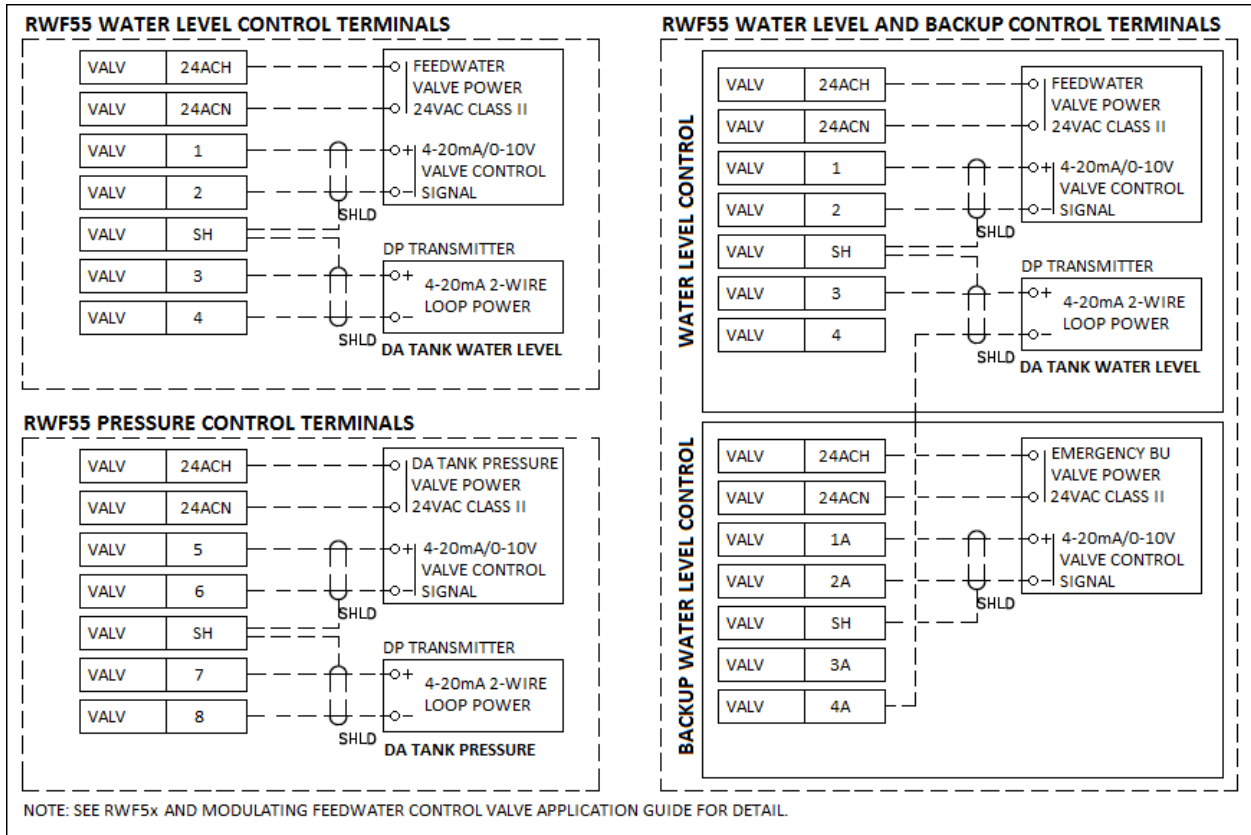

## Connections (continued)

### TS-D... series stand-alone DA tank piping and instrumentation diagram

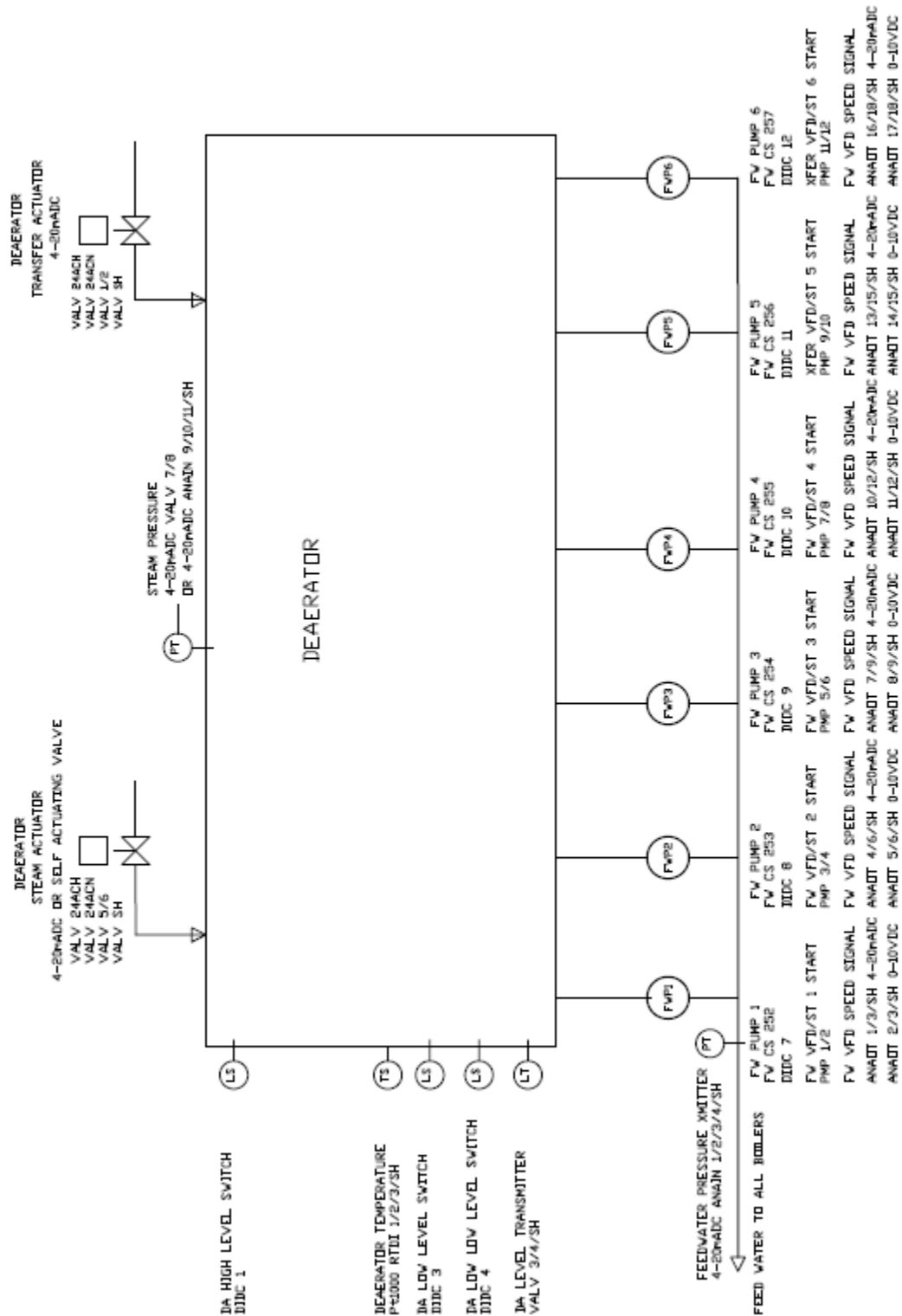

## Connections (continued)

### TS-DD... series two groups DA tank with feedwater pumps (continued)

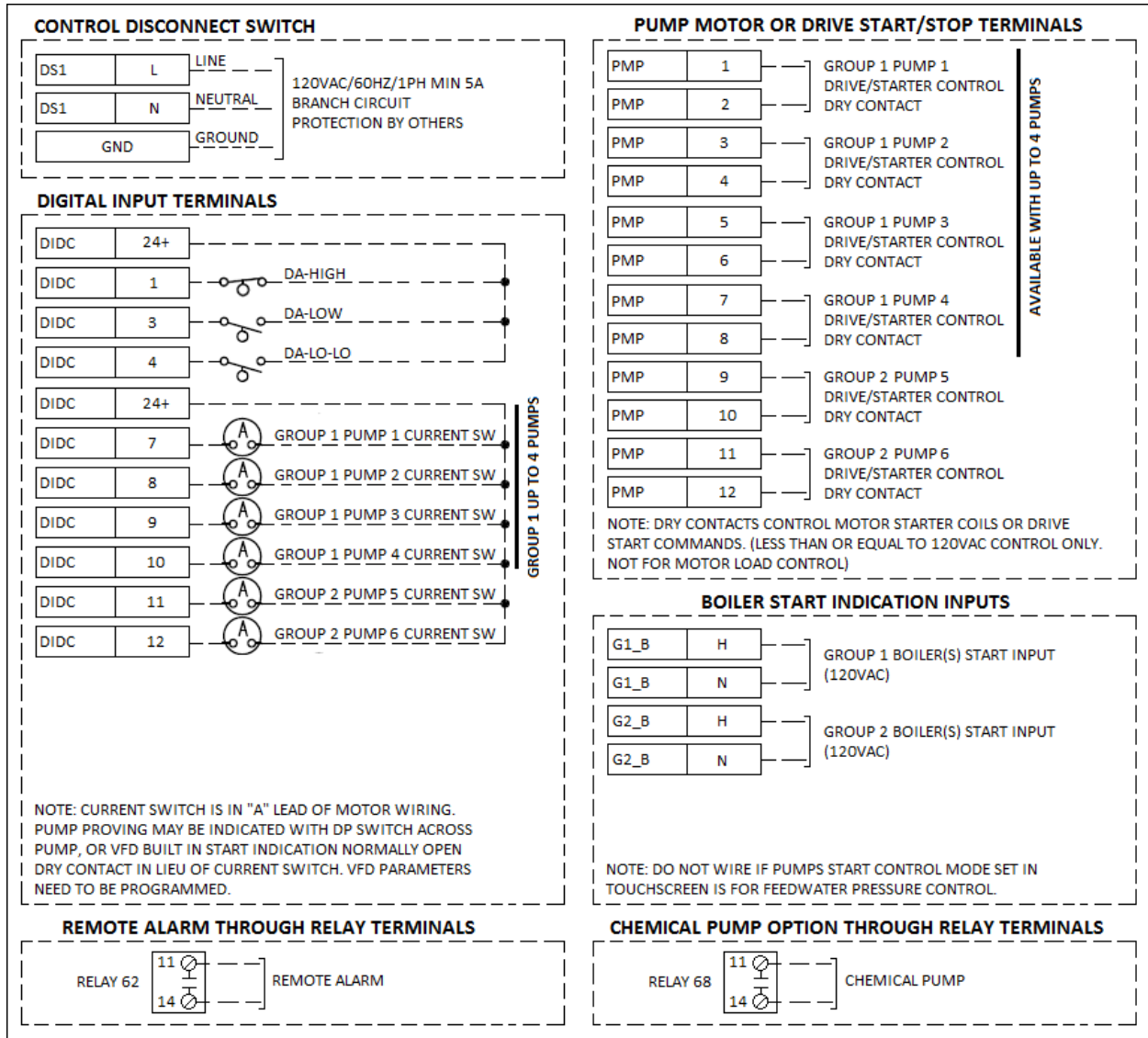

## Connections (continued)

### TS-DD... series two groups DA tank with feedwater pumps (continued)

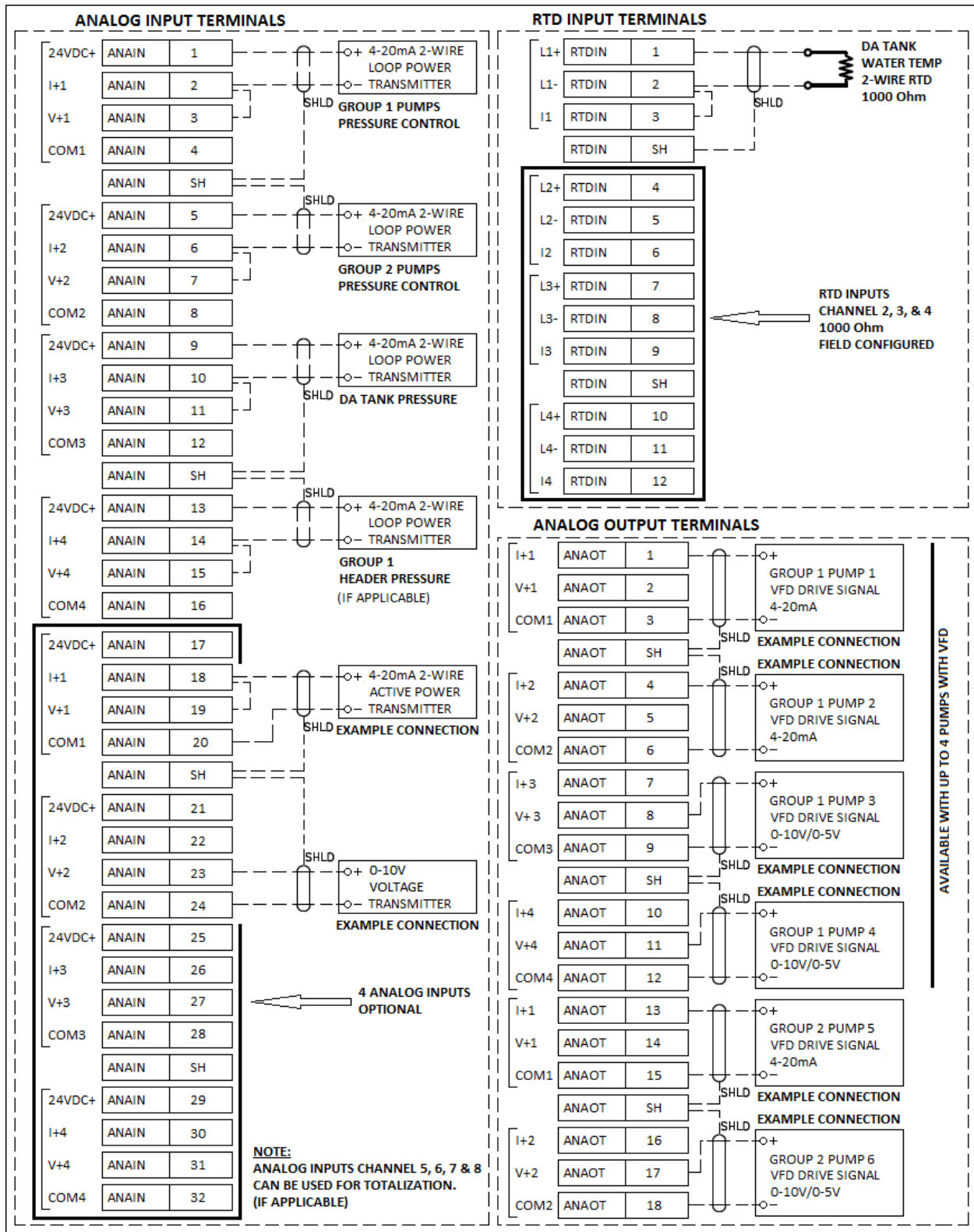

## Connections (continued)

### TS-DD... series two groups DA tank with feedwater pumps (continued)

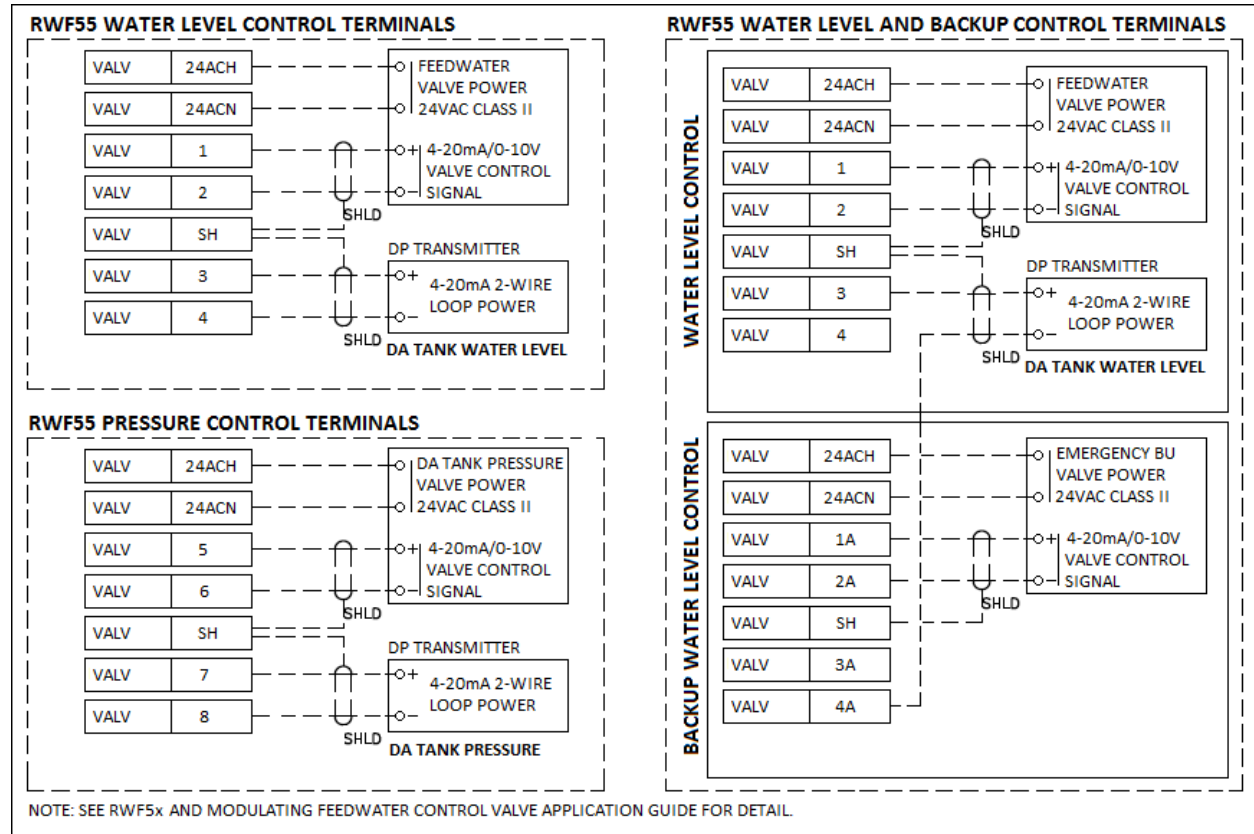

# Connections (continued)

## TS-DD... series stand-alone DA tank, two groups piping and instrumentation diagram

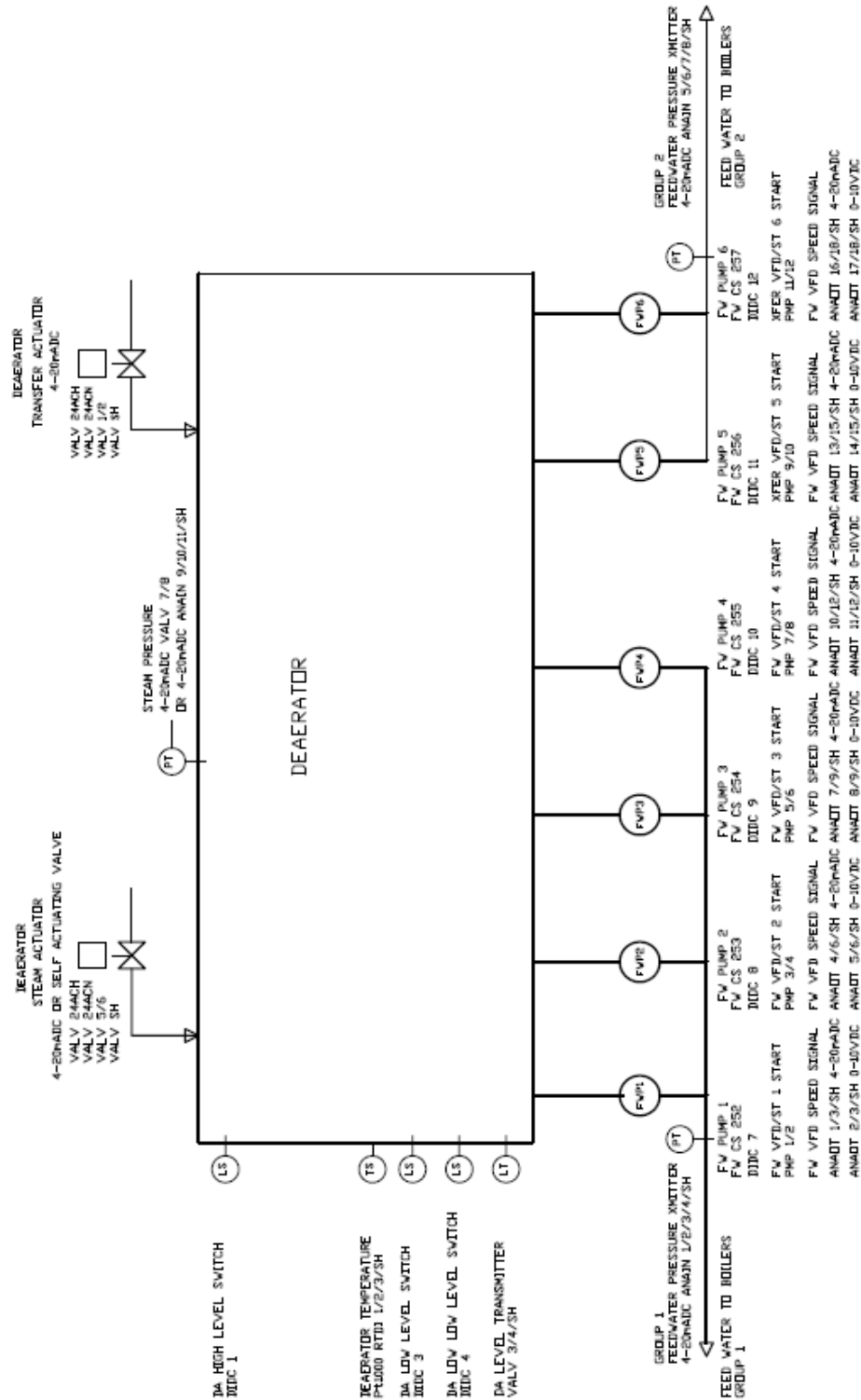

# Connections (continued)

## TS-S... series stand-alone surge tank with transfer pumps

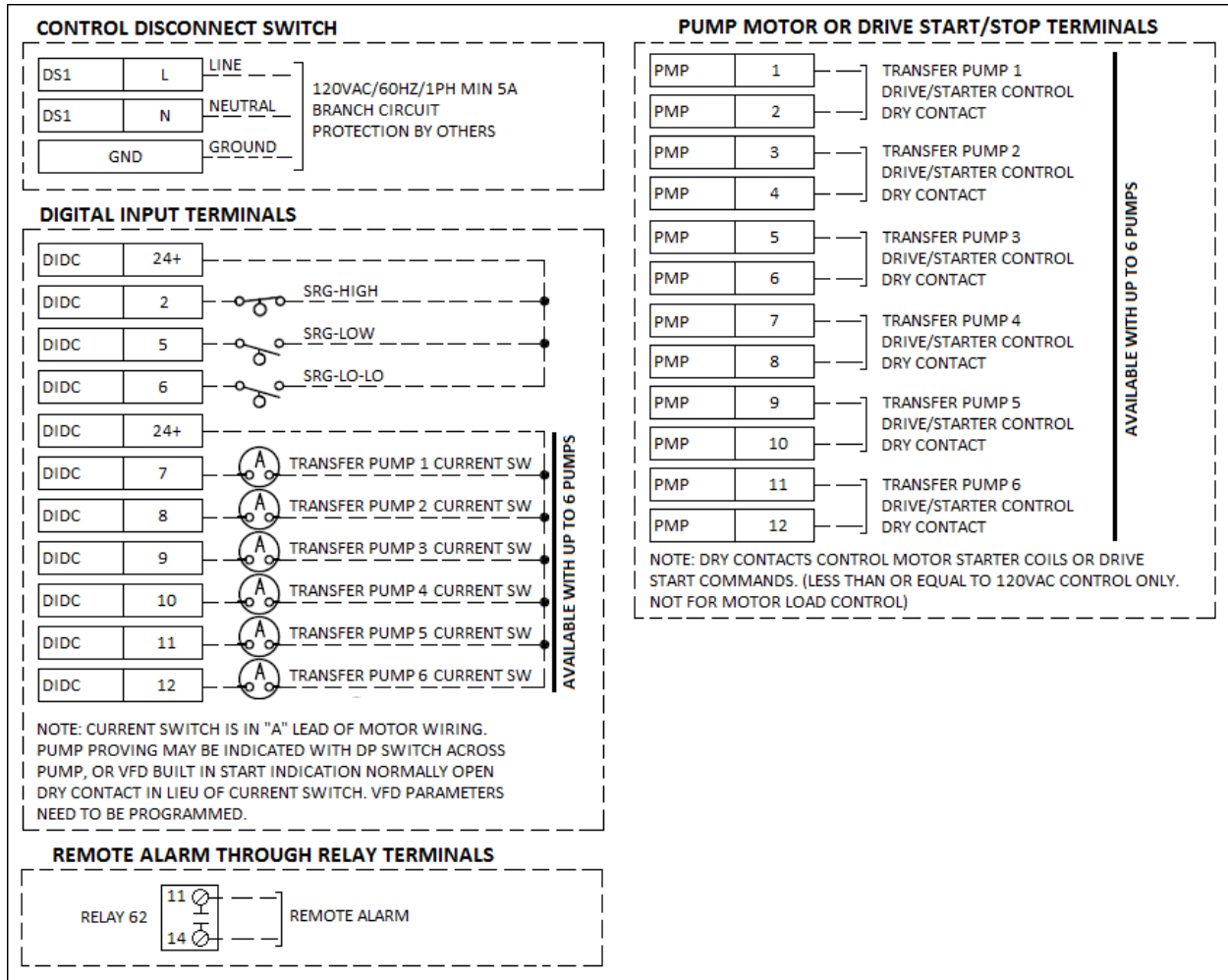

## Connections (continued)

### TS-S... series stand-alone surge tank with transfer pumps (continued)

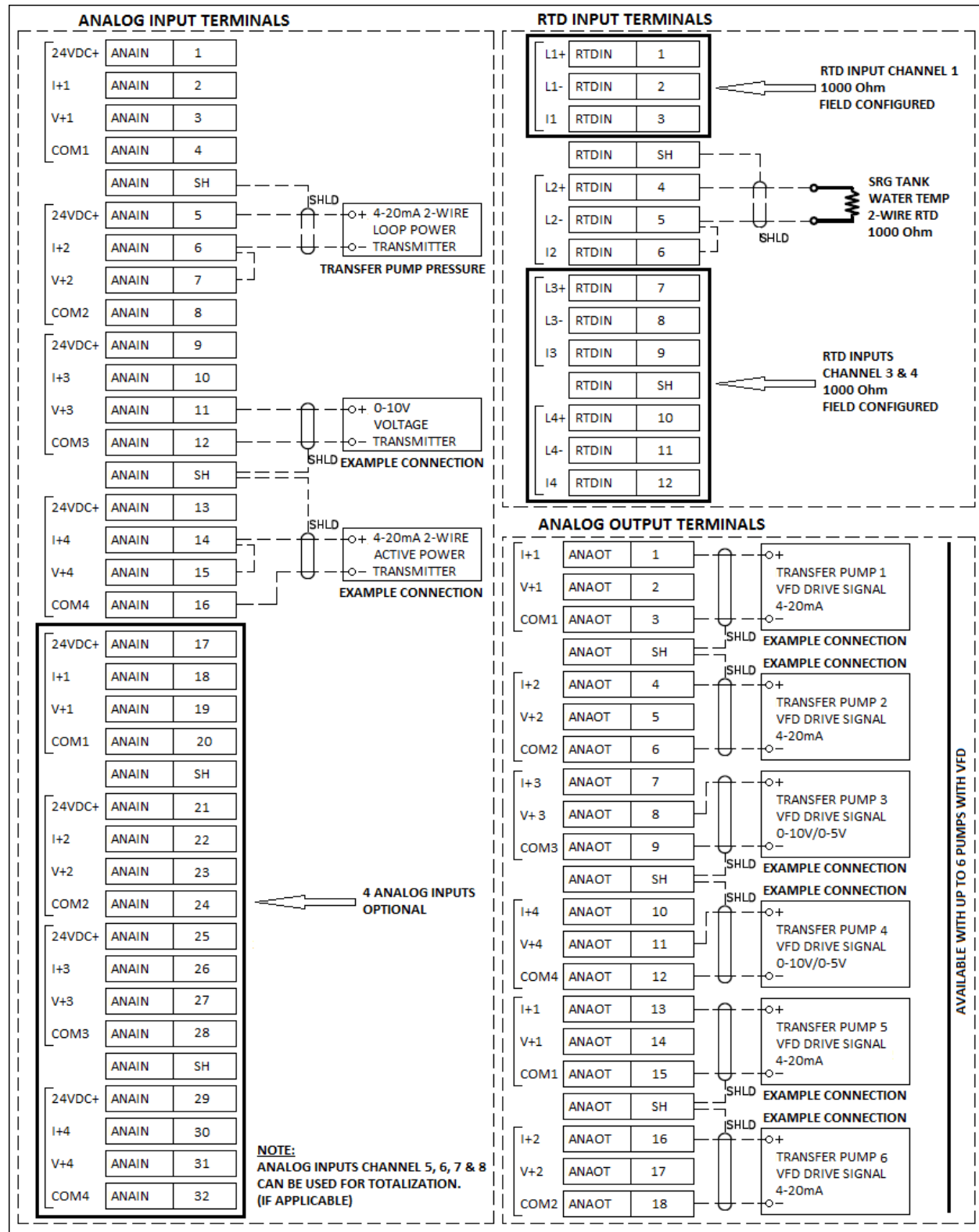



## Connections (continued)

### TS-S... series stand-alone surge tank with transfer pumps (continued)

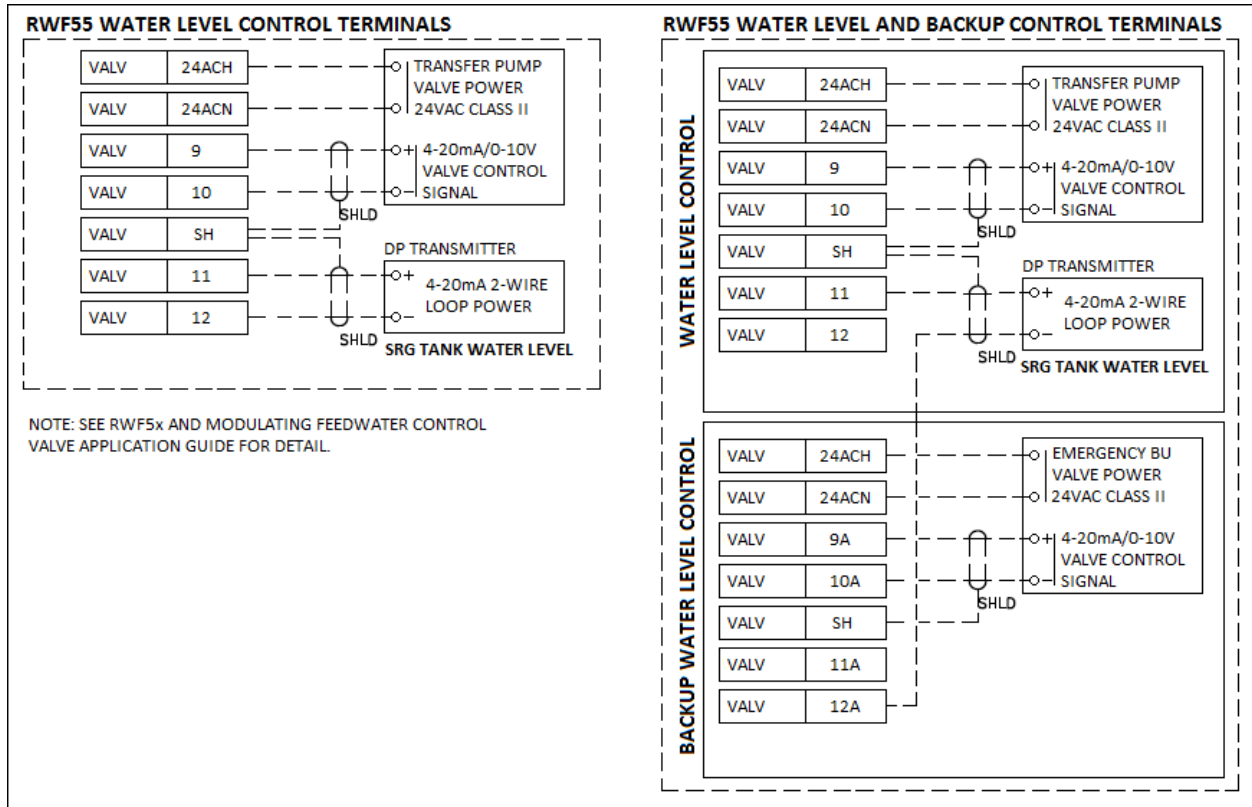

## Connections (continued)

### TS-S... series stand-alone surge tank piping and instrumentation diagram

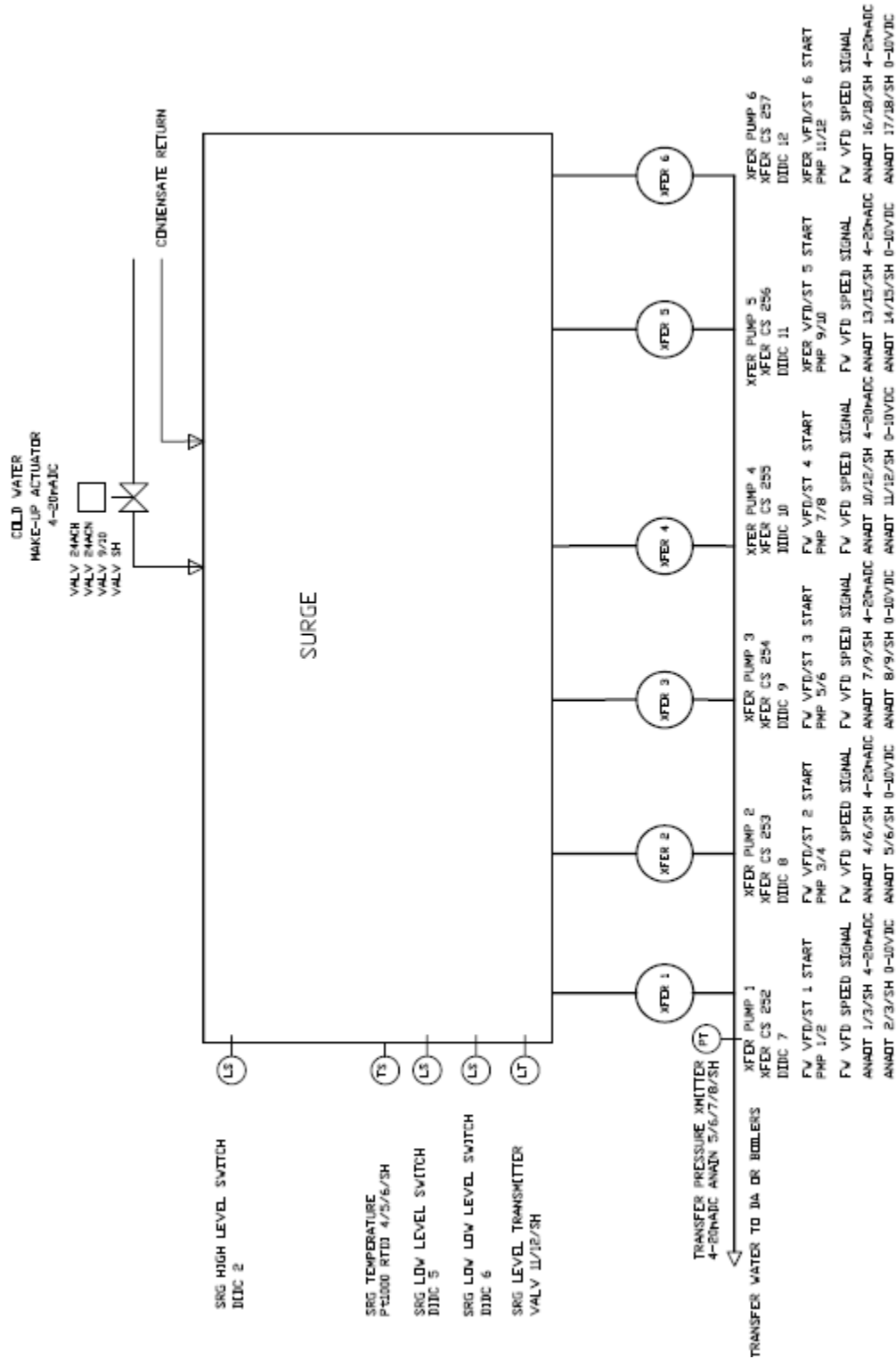

## Connections (continued)

### TS-C... series stand-alone condensate tank with two transfer pumps

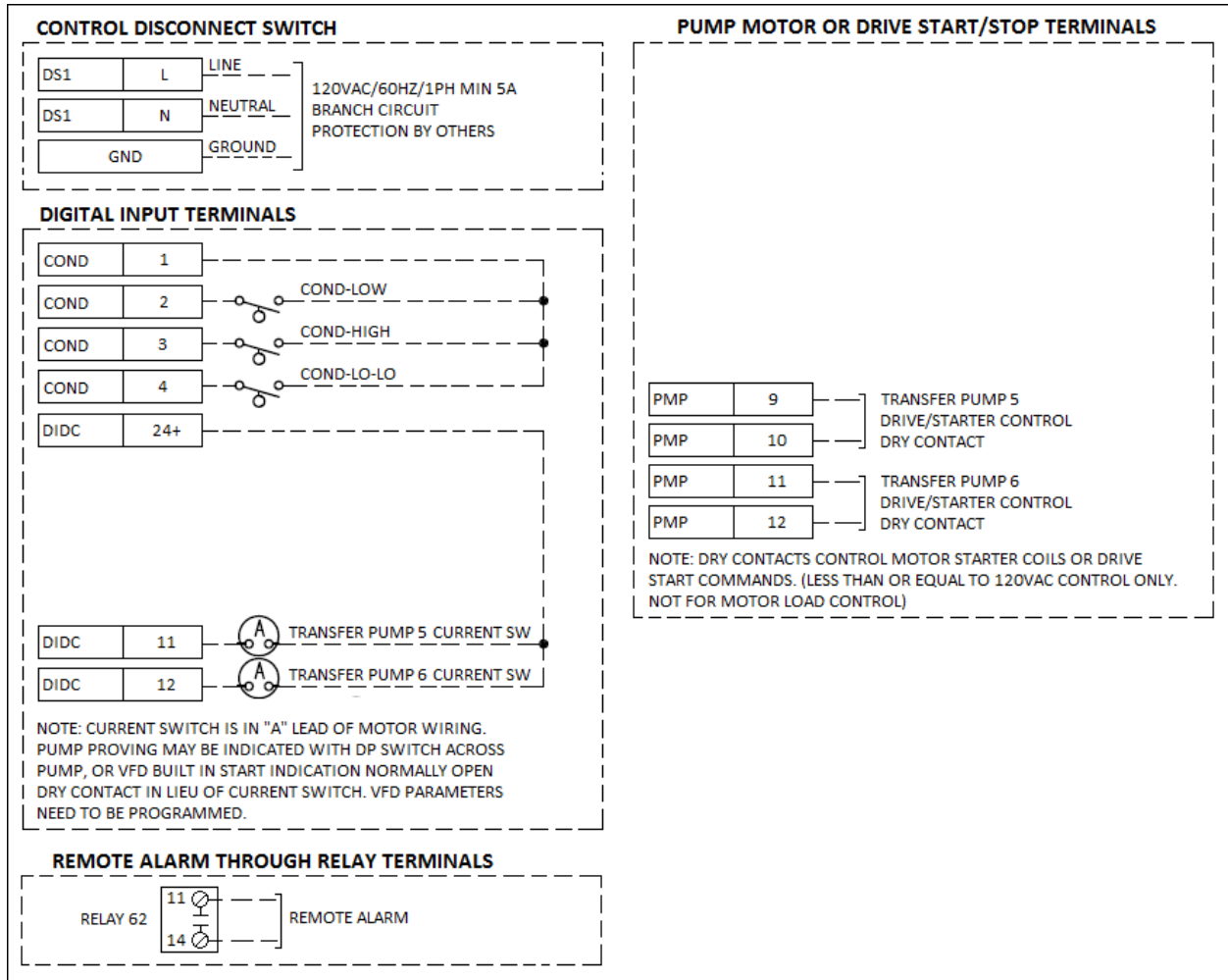

## Connections (continued)

### TS-C... series stand-alone condensate tank with two transfer pumps (continued)

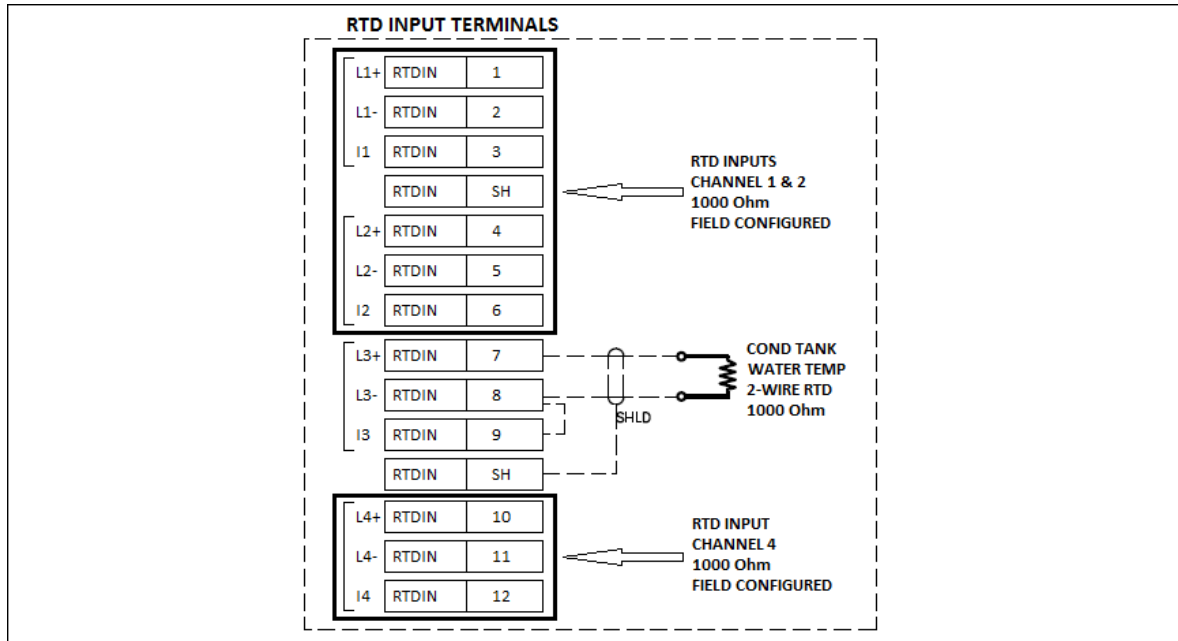

### Connections (continued)

TS-C... series condensate system piping instrumentation diagram

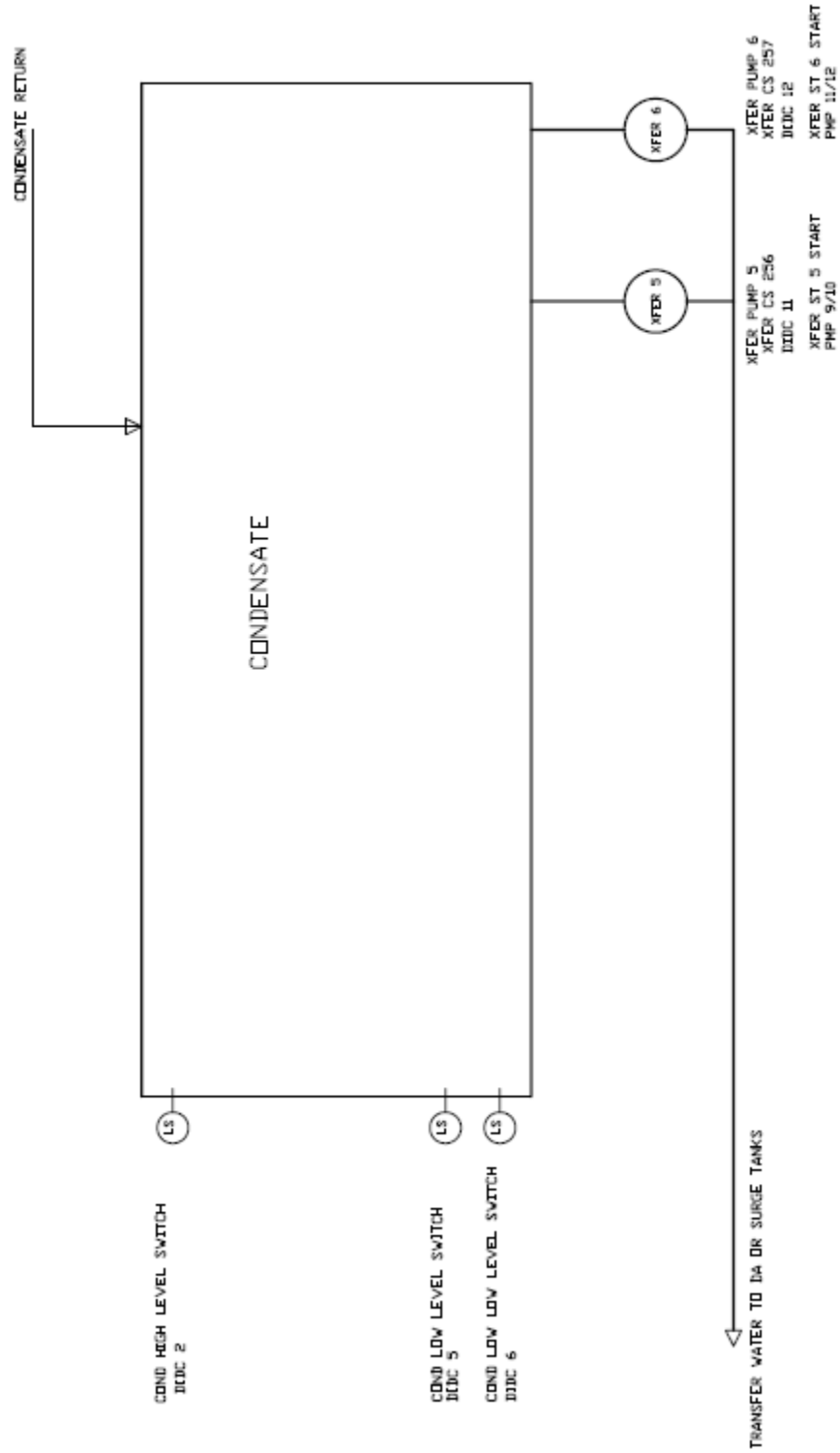

## Connections (continued)

### TS-DS... series DA/surge split tank with feedwater and transfer pumps (continued)

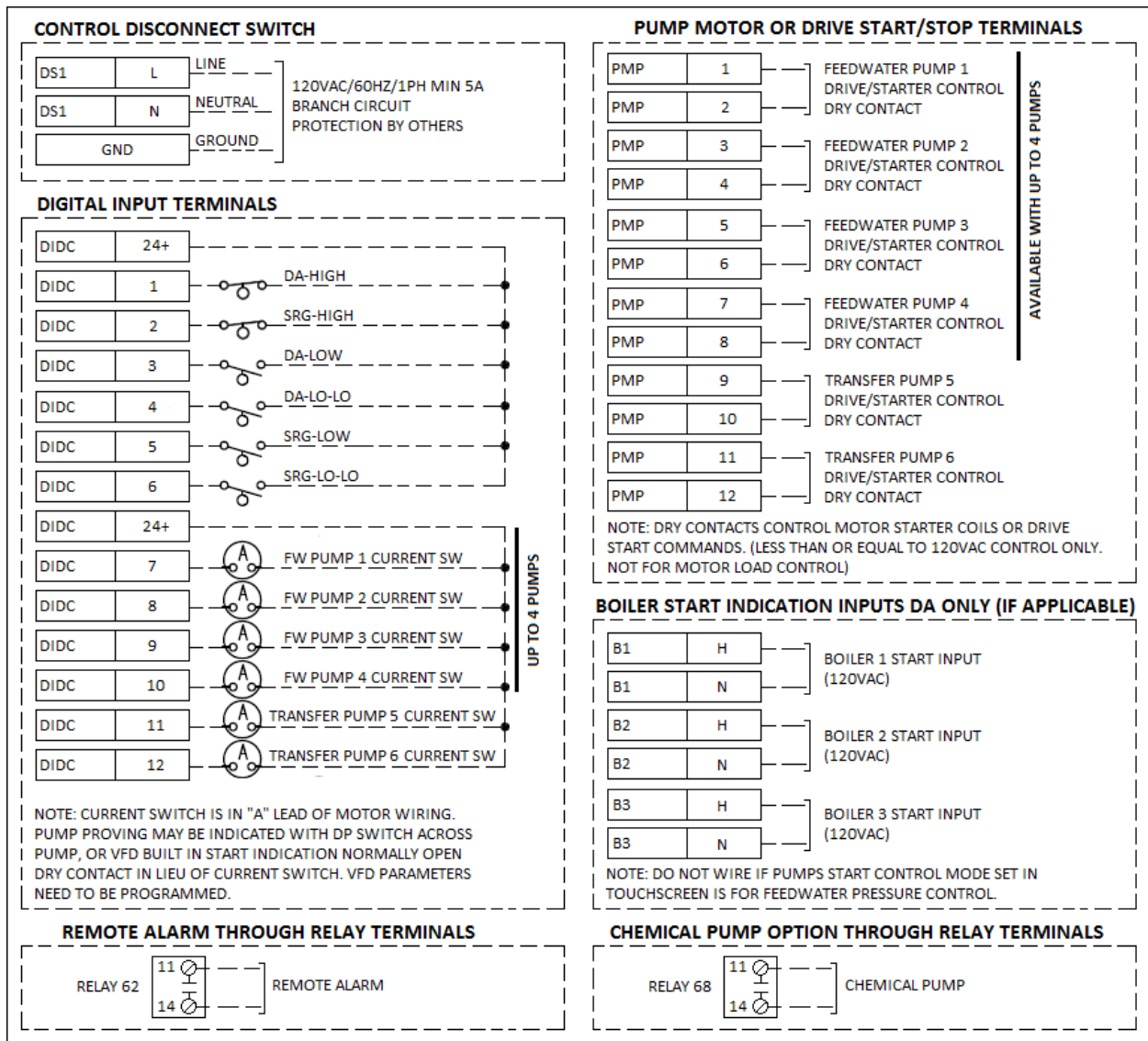

# Connections (continued)

## TS-DS... series DA/surge split tank with feedwater and transfer pumps (continued)

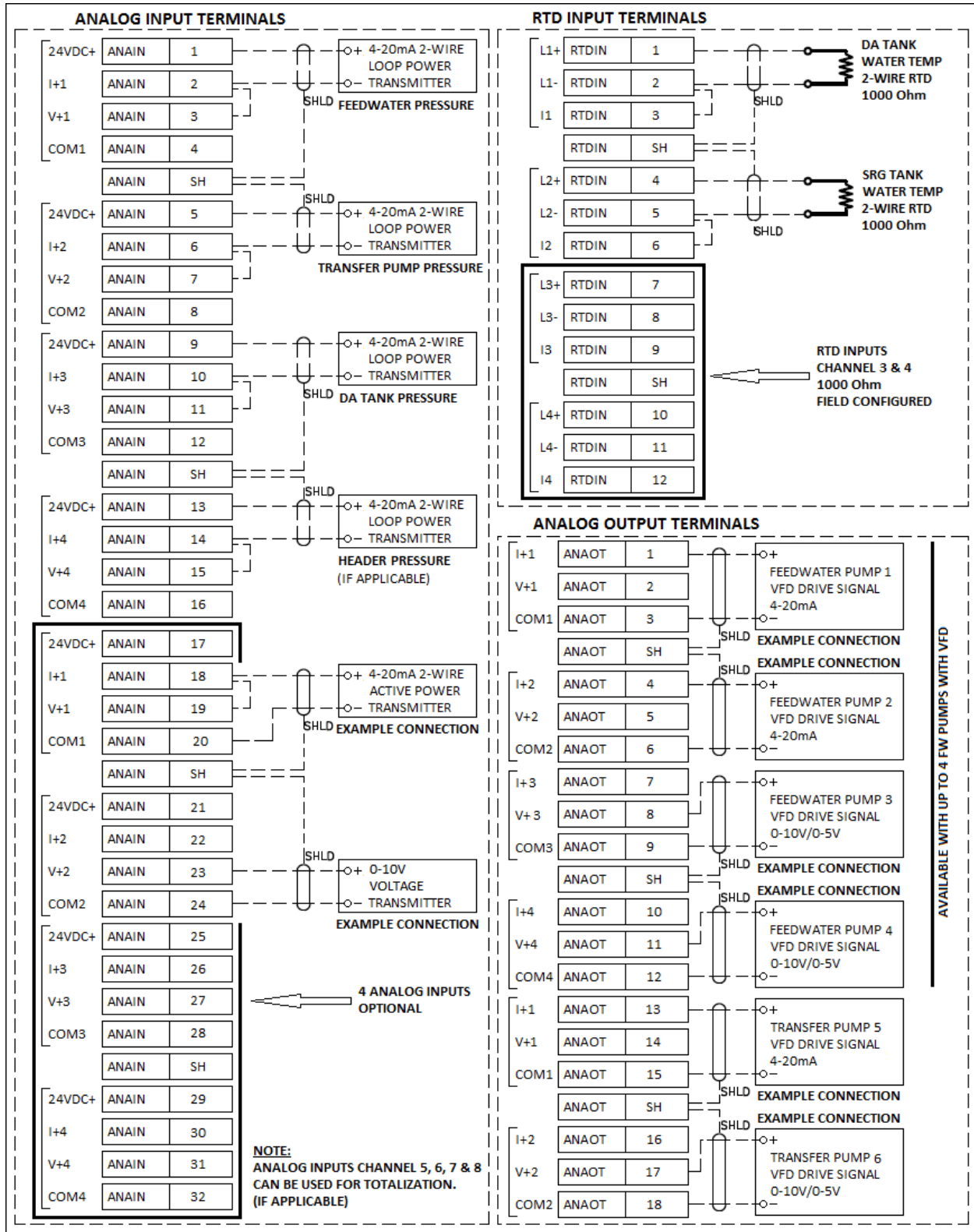

## Connections (continued)

### TS-DS... series DA/surge split tank with feedwater and transfer pumps (continued)

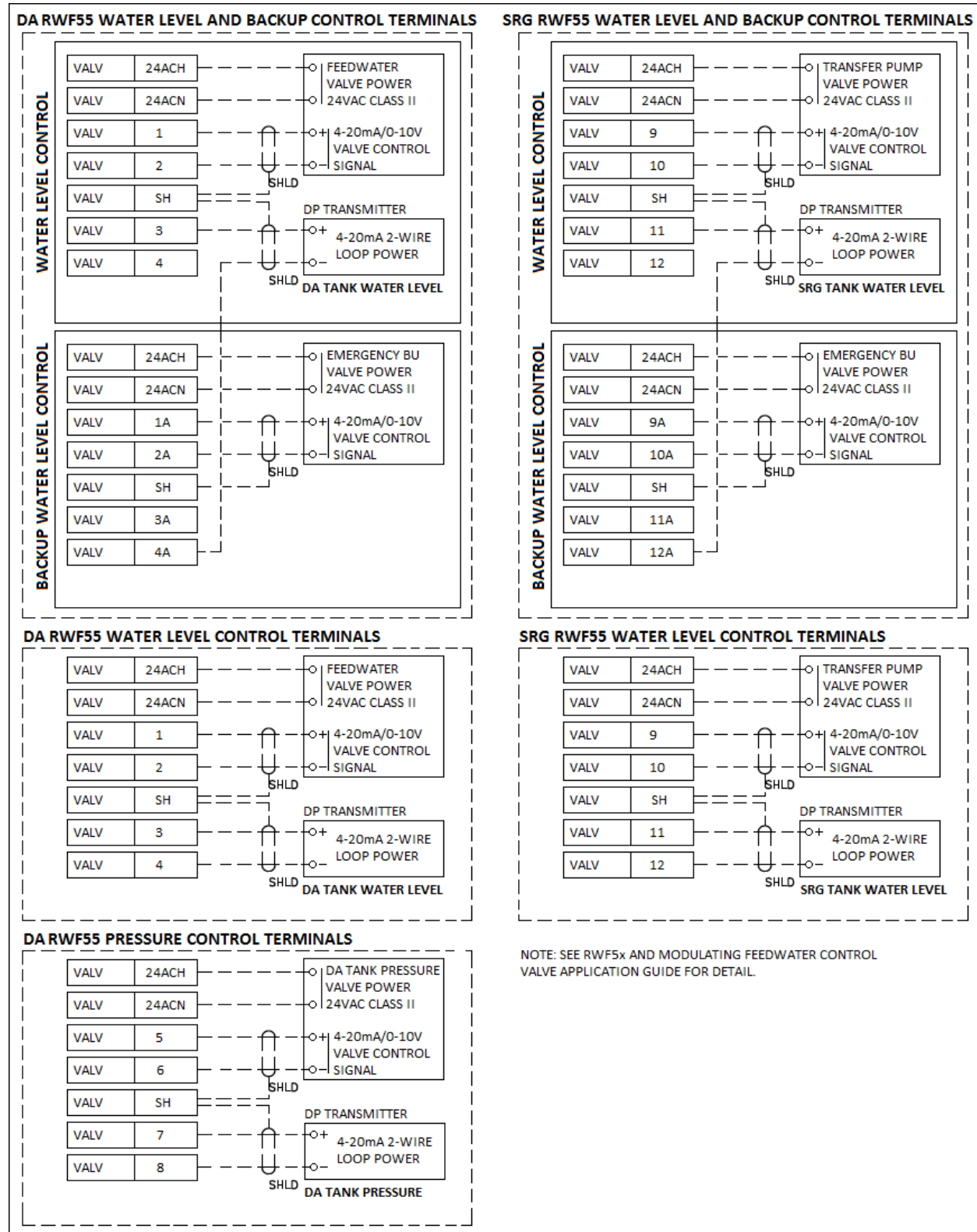



# Connections (continued)

## TS-DS... series split DA/surge system piping instrumentation diagram

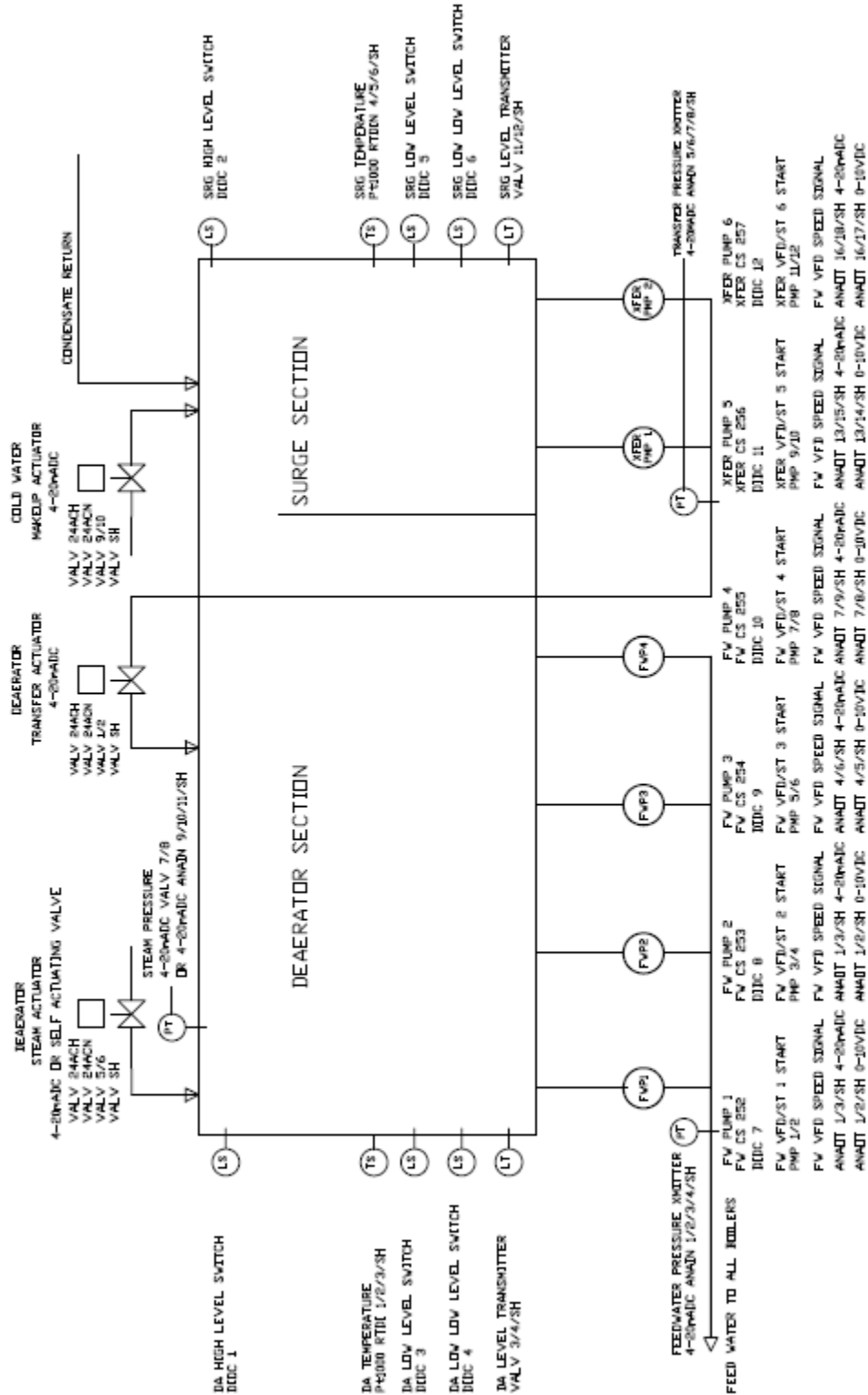

## Connections (continued)

### Building Management System Communications Connections

#### TS-DxxSxx-xxxx (Modbus TCP/IP connection to BMS or to SCC Master Lead/Lag Panel)

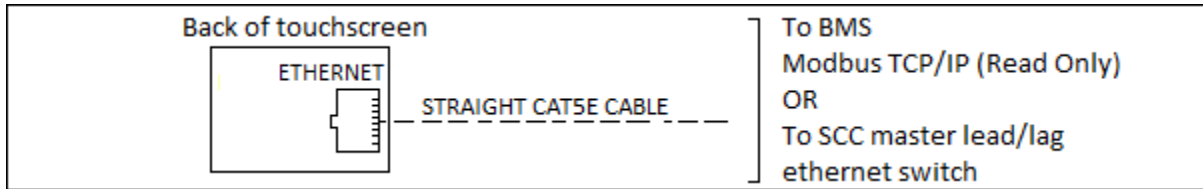

#### TS-DxxBxx-xxxx (BACnet/IP, EtherNet/IP, or PROFINET (RTA))

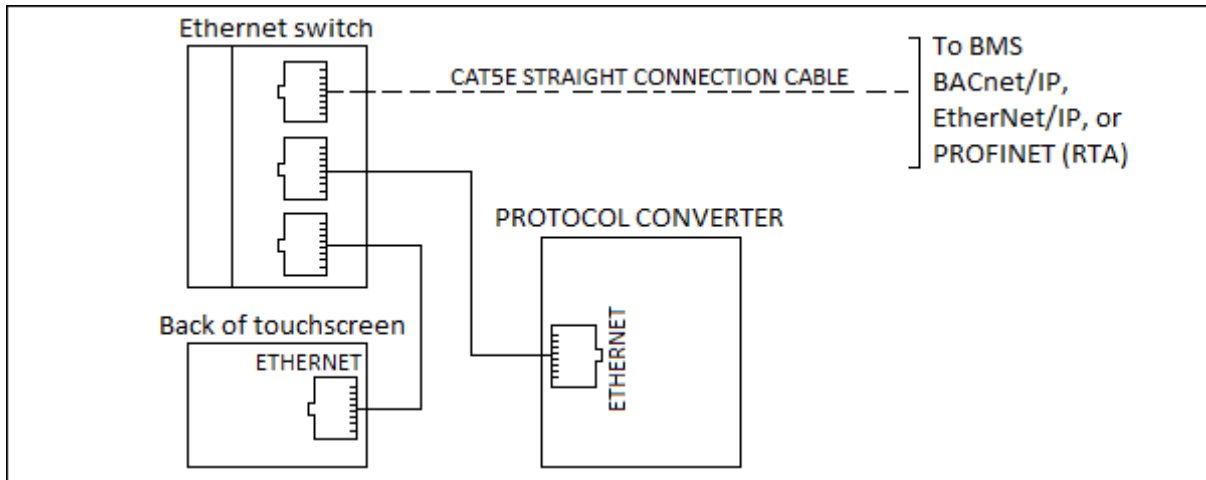

#### PROFIBUS

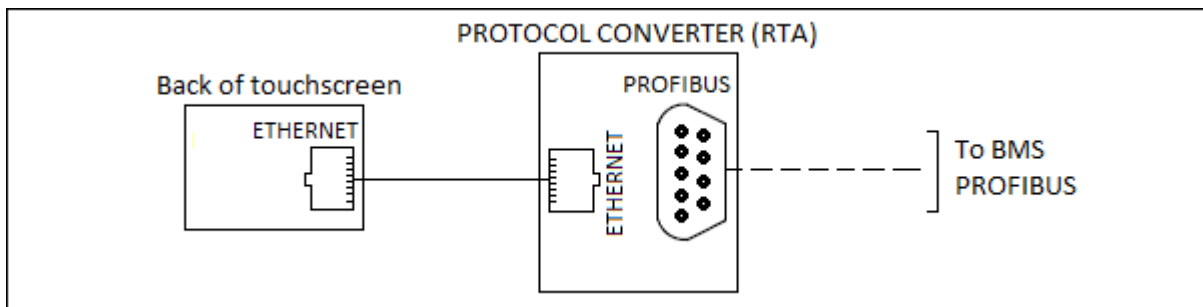

#### TS-DxxLxx-xxxx (LonWorks)

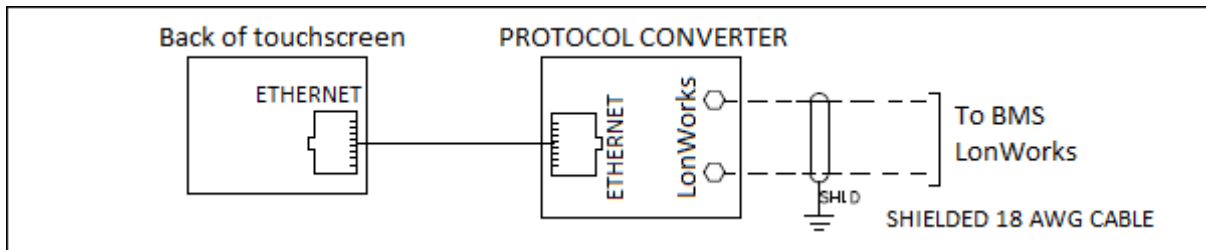

## Connections (continued)

### Building Management System Communications Connections (continued)

TS-DxxNxx-xxxx (N2 Johnson Metasys, Modbus RTU, or BACnet MS/TP)

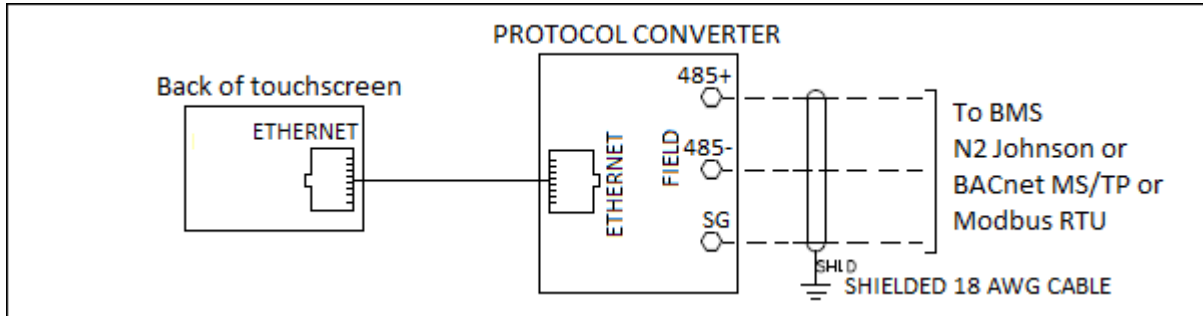

## Enclosure Internal Parts Description

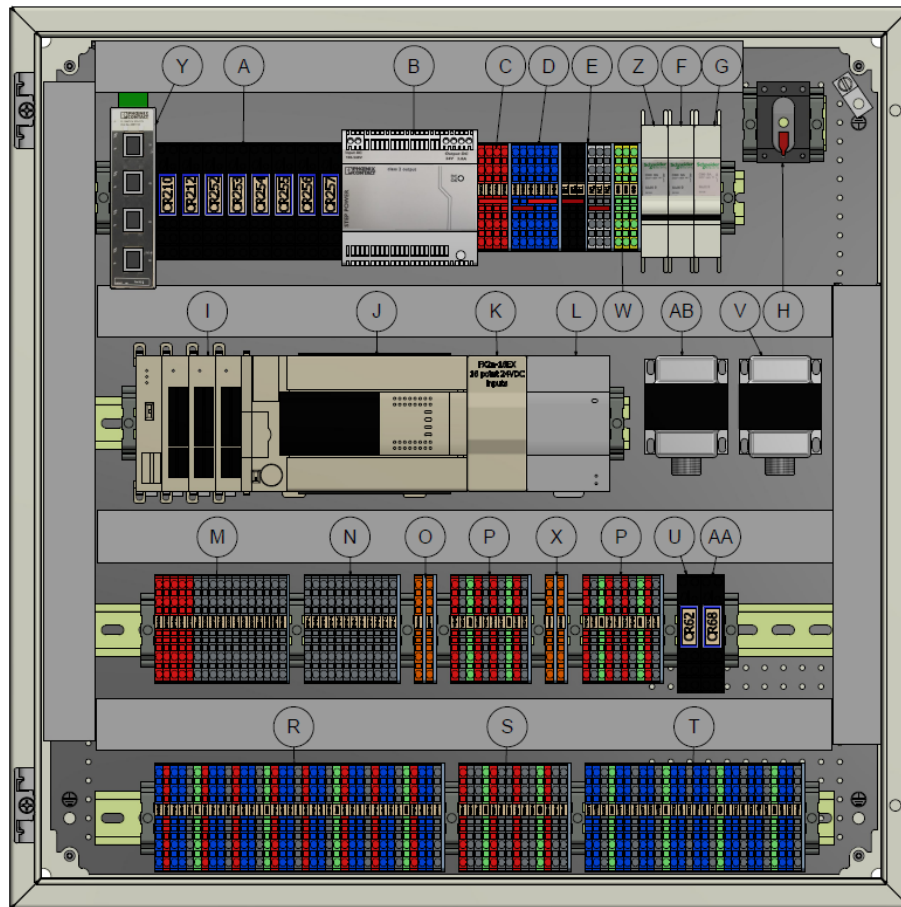

<b>A.</b>	Pump and DA/Surge low water relays	<b>O.</b>	24 VAC feedwater actuator power terminals
<b>B.</b>	24VDC power supply	<b>P.</b>	4-20 mA feedwater modulating output terminals and 4-20 mA level DP terminals
<b>C.</b>	24 VDC (+) terminals	<b>Q.</b>	BMS interface for communications other than Modbus
<b>D.</b>	24 VDC (-) terminals	<b>R.</b>	Analog input terminals
<b>E.</b>	120 VAC terminals	<b>S.</b>	RTD input terminals
<b>F.</b>	Water level circuit breaker for V	<b>T.</b>	VFD analog output terminals
<b>G.</b>	System power circuit breaker	<b>U.</b>	Alarm relay output terminals
<b>H.</b>	System 120 VAC disconnect	<b>V.</b>	Feedwater valve 24 VAC transformer
<b>I.</b>	Analog and RTD input modules	<b>W.</b>	Ground terminals (PE)
<b>J.</b>	Programmable logic controller (PLC)	<b>X.</b>	2 <sup>nd</sup> VAC feedwater actuator power terminals
<b>K.</b>	Digital input module	<b>Y.</b>	5-Ports Ethernet switch
<b>L.</b>	Analog input module	<b>Z.</b>	Water level circuit breaker for AB
<b>M.</b>	Digital input terminals	<b>AA.</b>	Chemical pump relay
<b>N.</b>	Pump start/stop terminals	<b>AB.</b>	2 <sup>nd</sup> feedwater 24 VAC transformer

## Enclosure Dimensions

Dimensions in inches; millimeters in brackets

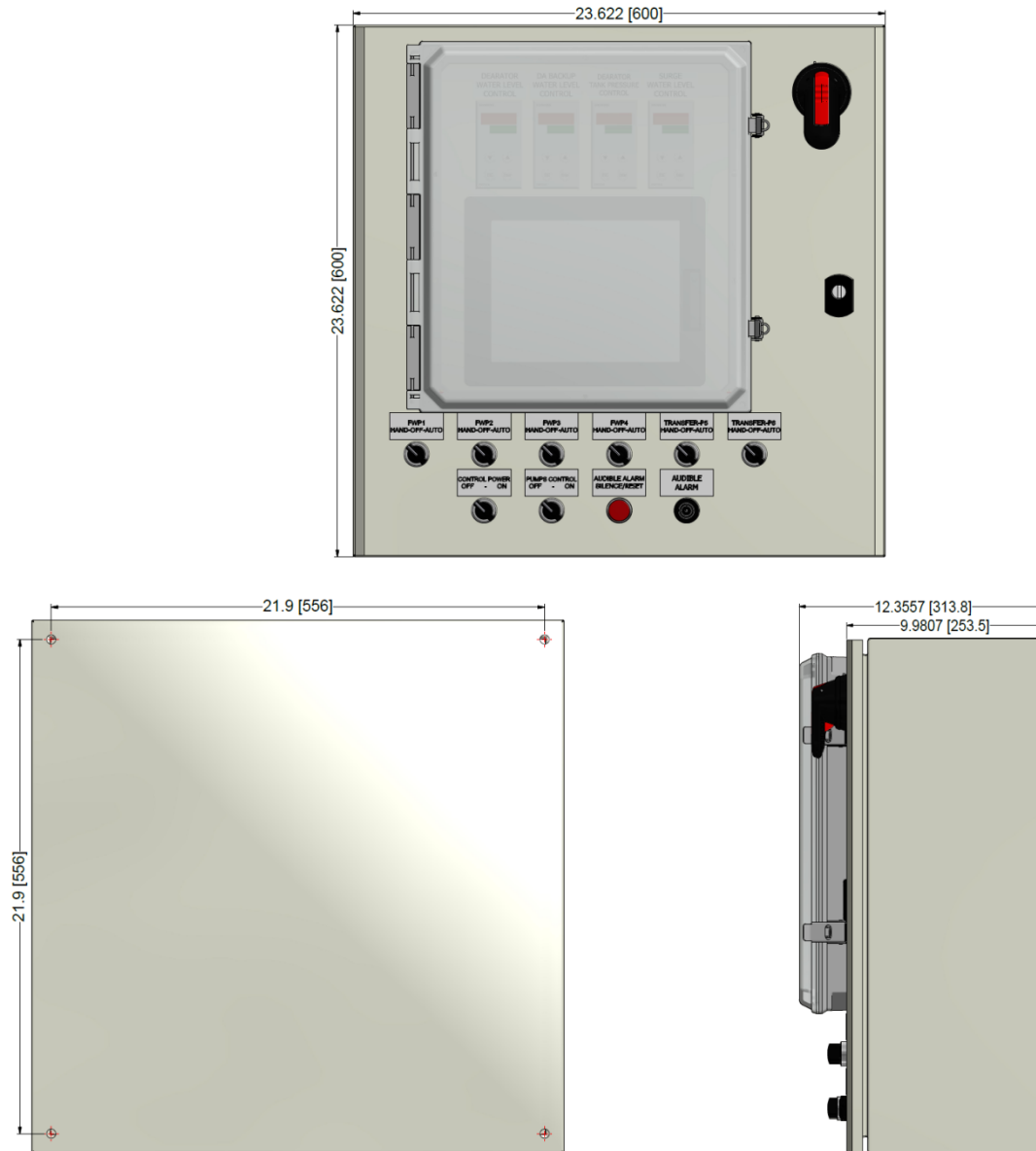

Information in this publication is based on current specifications. The company reserves the right to make changes in specifications and models as design improvements are introduced. Product or company names mentioned herein may be the trademarks of their respective owners. © 2009 SCC Inc.