

BR...CBAIR Rotary Air Damper Retrofit Kits

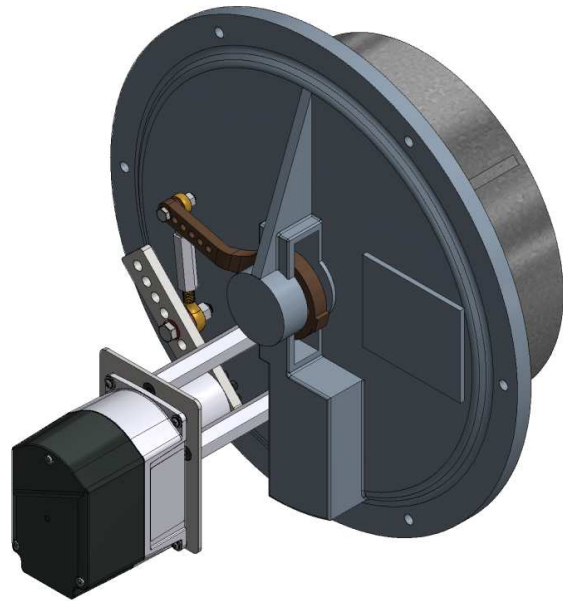

Product Description

A BR...CBAIR retrofit kit reliably mounts an SQM33, SQM45, or SQM48 actuator to a Cleaver Brooks boiler rotary air damper with an outer flange diameter of 18.25".

Recommended Installation Tools

The following tools / supplies are recommended for bracket assembly installation:

1. Fine tip marker
2. Center punch (with hammer)
3. Drill with #6 (0.204") drill bit
4. Aluminum tapping fluid (Tap Magic)
5. Tap holder with 1/4"-20 spiral-point tap
6. Drill and tap guide (included in kit)
7. Set of standard open end wrenches up to 3/4". Should have two 7/16" and two 3/8" wrenches.
8. Set of standard hex keys
9. Phillips screwdriver
10. Medium threadlocker

Components Supplied

Figure 1 shows all of the components that are supplied with a BR...CBAIR retrofit kit.

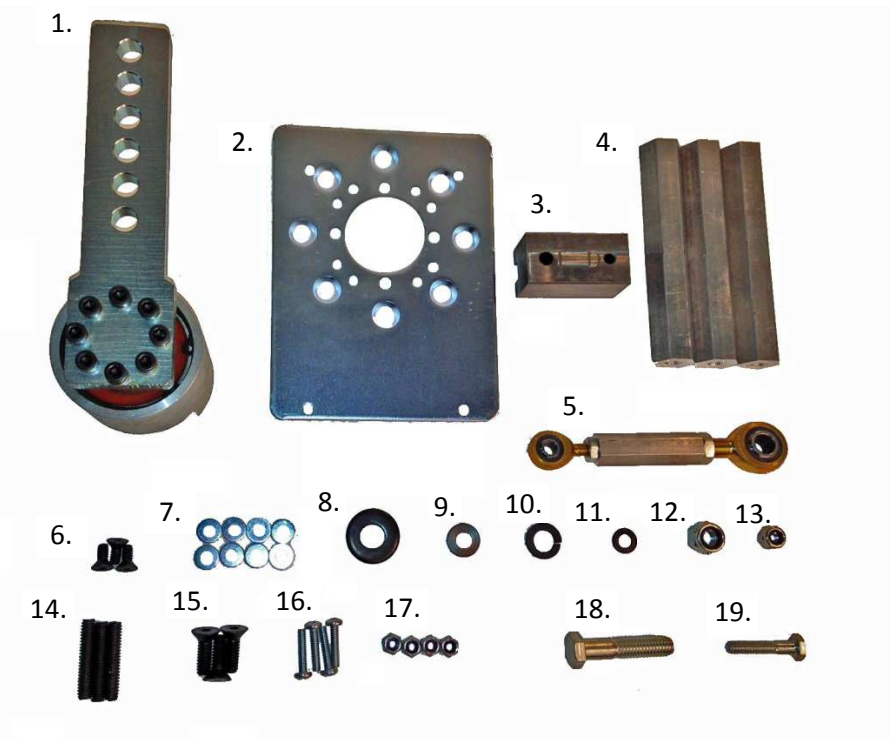

Figure 1: Components Included in a BR...CBAIR Rotary Air Damper Retrofit Kit

- | | |
|--|--|
| 1. Bearing block crank arm assembly | 11. 1/4" lock washer |
| 2. Actuator base plate | 12. 3/8" lock nut |
| 3. Drill / tap guide | 13. 1/4" lock nut |
| 4. 4.5" hex standoffs (qty 3) | 14. 1/4"-20 x 1.25" studs (qty 3) |
| 5. Turnbuckle assembly | 15. 1/4"-20 x 0.75" flat head screws (qty 3) |
| 6. #10-24 x 0.44" flat head screws (qty 3) | 16. #8-32 x 0.75" pan head screws (qty 4) |
| 7. #8 SAE flat washers (qty 8) | 17. #8-32 lock nuts (qty 4) |
| 8. 3/8" spacer | 18. 3/8"-16 x 1.75" hex head screw |
| 9. 1/4" spacer | 19. 1/4"-20 x 1.25" hex head screw |
| 10. 3/8" lock washer | |

Installation Procedure

1. Unbolting and removing the drawer / air damper assembly from the boiler is recommended (see Figure 2). This drawer assembly has an outer diameter of approximately 18.25”.

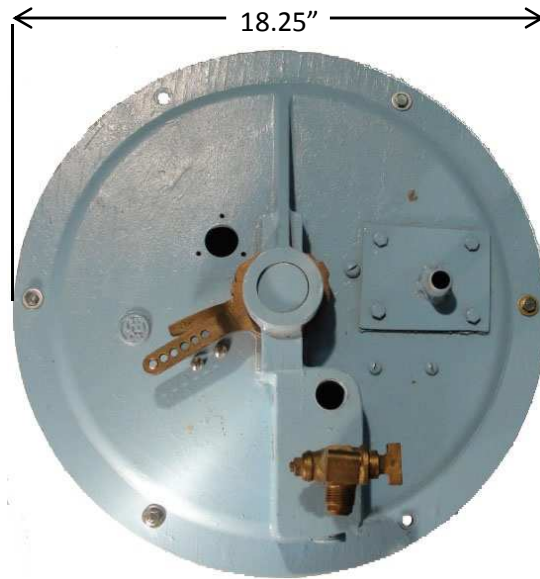

Figure 2: Typical Drawer / Air Damper Assembly

2. Mark the positions to be drilled using the actuator base plate as a template. The holes to be drilled are at the 12, 3, and 6 o'clock positions on the actuator base plate. The actuator base plate should be flush against the casting as shown in Figure 3.

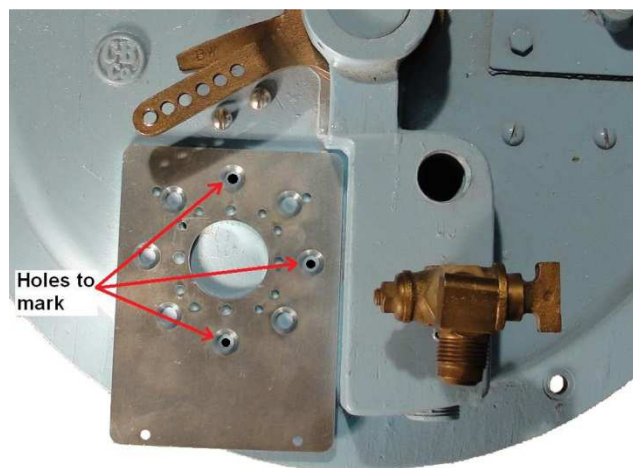

Figure 3: Using the Actuator Base Plate as a Template

3. After the positions are marked, center punch each. Then using the #6 drill bit and drill, start each hole no more than 1/8" deep. **NOTE: Accurate marking of the holes is very important so that the standoffs are properly located and will line up with the actuator base plate. Accuracy on this step is recommended.**

After this step, the drawer should look like Figure 4.



Figure 4: Drawer with Holes Marked and Started

4. Insert the #6 drill bit through the "D" side of the drill / tap guide and into one of the holes started in step 3. Press the drill / tap guide firmly against the face of the drawer so the hole is drilled as perpendicular to the face as possible. Drill completely through the drawer assembly. Repeat the same procedure on the other two holes started in step 3. This arrangement is shown in Figure 5 below.

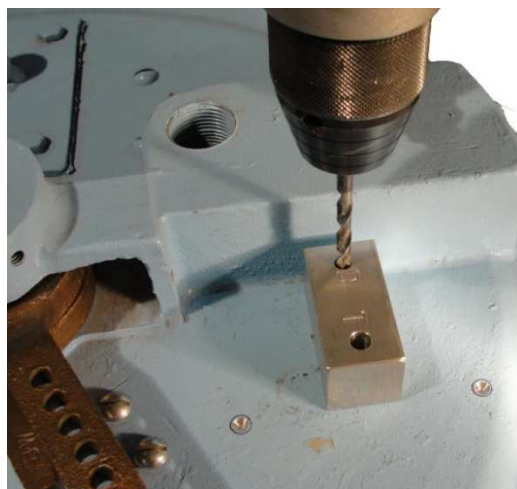

Figure 5: Drilling Holes Perpendicular to Drawer Face

5. After the holes are drilled, they can be tapped with a $\frac{1}{4}$ "-20 tap. A spiral-point tap and aluminum tapping fluid (Tap Magic) are recommended for tapping these holes. Using the side of the drill / tap guide marked "T", press the guide firmly against the drawer face and tap each of the 3 drilled holes. Figure 6 illustrates a spiral-point tap and the use of the drill / tap guide.



Figure 6: Tapping Holes with Guide and Spiral-Point Tap

6. By hand, thread one $\frac{1}{4}$ "-20 x 1.25" stud into one end of a hex standoff until the stud cannot be threaded in any further. Repeat twice more so that all three standoffs have $\frac{1}{4}$ "-20 studs threaded into one end. Thread stud / standoff assemblies into holes that were just tapped in step 5. Tighten standoffs; however do not tighten to the point of twisting off the studs or stripping the threads out of the drawer. At this point, the assembly should look like Figure 7.

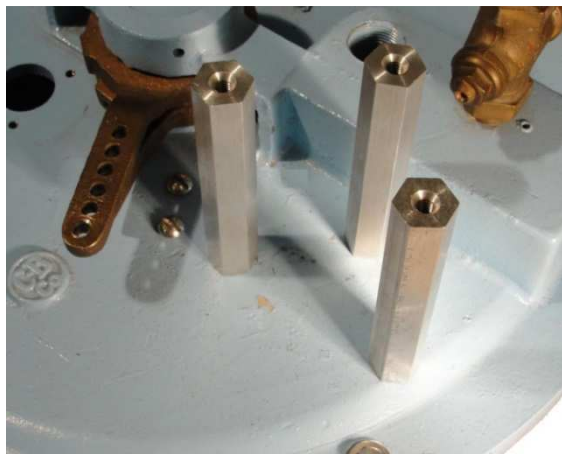

Figure 7: Standoffs Installed and Tightened

7. Place a small amount of medium threadlocker on the $\frac{1}{4}$ "-20 x 0.75" flat head screws. Thread the screws through the plate and into the standoffs. Figure 8 shows the assembly after this step.

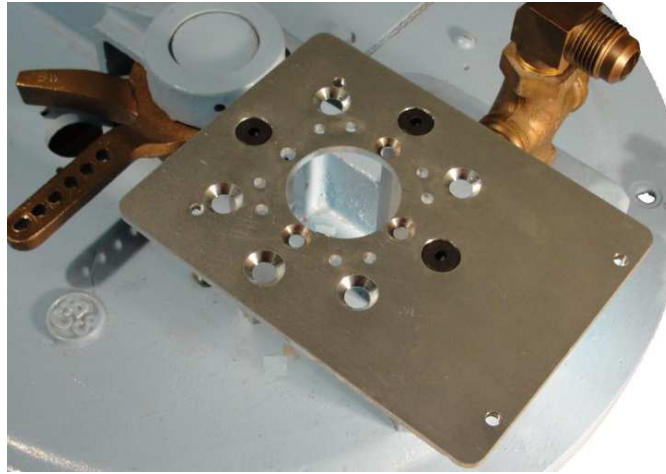

Figure 8: Actuator Base Plate Installed

8. Place a small amount of medium threadlocker on the #10-24 x 0.44" flat head screws. Install the bearing block assembly onto the actuator base plate by threading the screws through the plate and into the bearing block with the lever arm at approximately the 8 o'clock position. Figure 9 shows the assembly after this step.

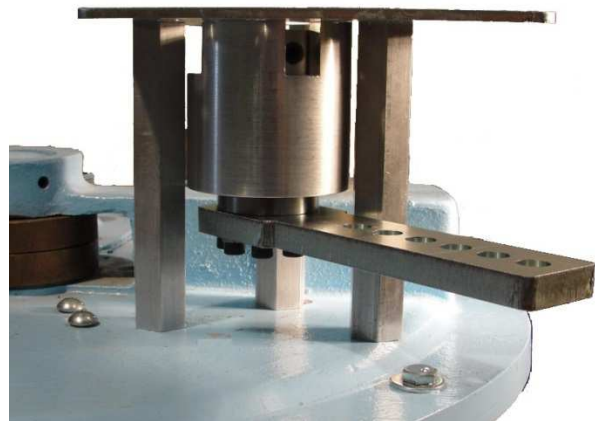

Figure 9: Bearing Block Installed

9. Mount the SQM... actuator to the actuator base plate using the four #8-32 x 0.75" pan head screws, eight #8 SAE washers, and four #8-32 locknuts. Figure 10 shows the assembly after this step.

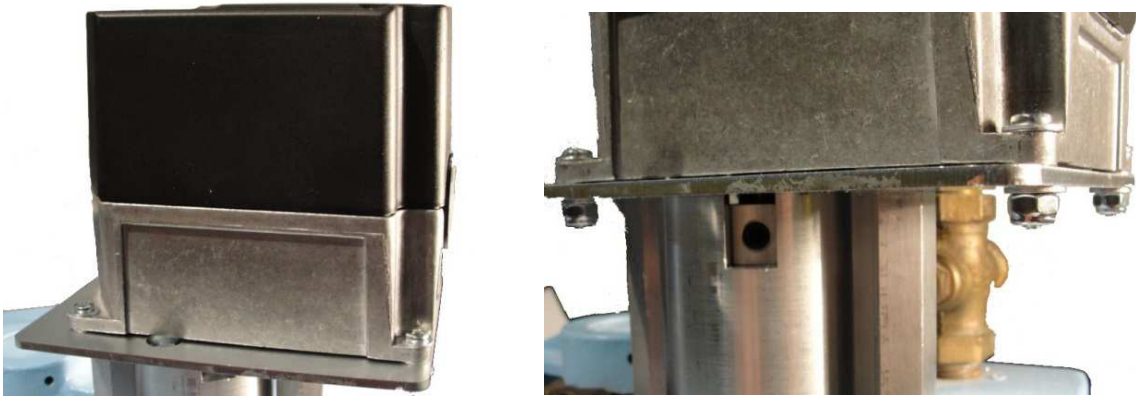

Figure 10: SQM... Actuator Installed

10. Tighten clamp collar set screws. These three screws squeeze the bearing block shaft and clamp the actuator shaft. Two of the set screws can be accessed and tightened with the actuator in the 0-degree position. The third set screw (which is blocked by a standoff when the actuator is at the 0-degree position) needs to be tightened when the actuator is at approximately the 20-degree position. Two of these set screws are shown in Figure 11 below.

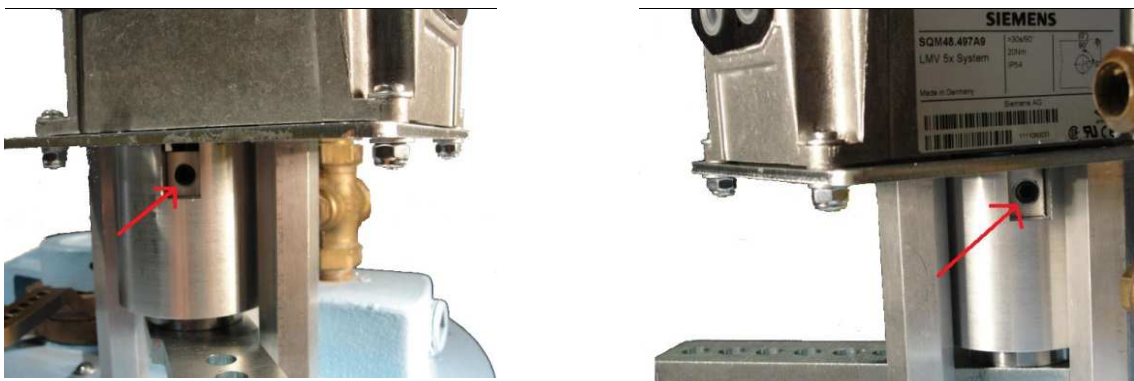

Figure 11: Tightening Clamp Collar Set Screws

11. Adjust the turnbuckle assembly. The turnbuckle assembly will get longer or shorter as the center hex piece is rotated since one rod end has right-hand threads and the other rod end has left-hand threads. The length of the turnbuckle assembly will vary slightly from installation to installation. Figure 12 shows the approximate length of the turnbuckle assembly for this installation. Figure 12 also shows the maximum distance each rod end can be extended out of the hex piece while still maintaining safe thread engagement.

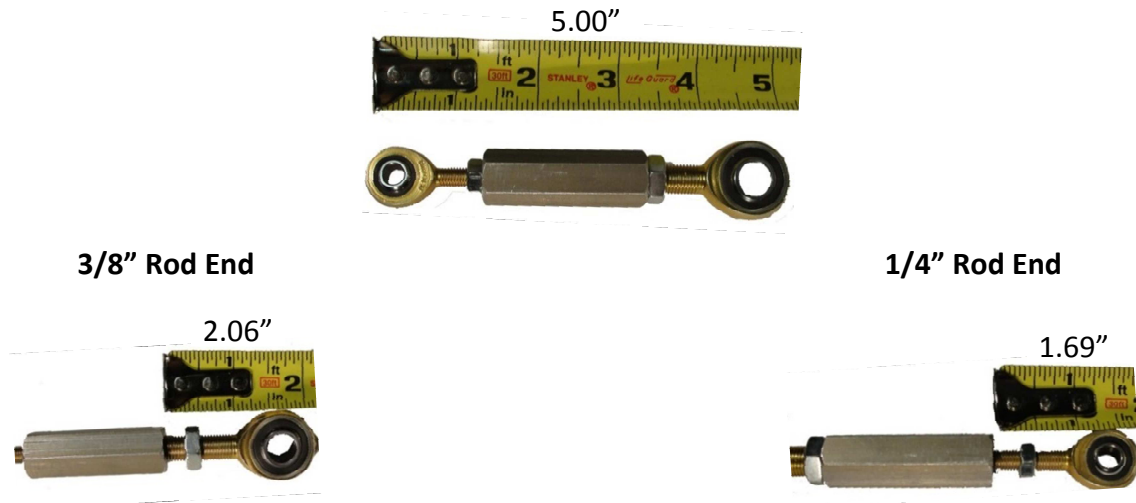

Figure 12: Turnbuckle Assembly Length / Extension Limits

12. Using the 3/8"-16 x 1.75" and 1/4"-20 x 1.25" bolts in combination with the lock washers, spacers, and lock nuts, install the turnbuckle assembly. The smaller rod end (1/4") of the turnbuckle assembly connects to the existing bronze crank arm on the air damper, and the larger rod end (3/8") connects to the bearing block assembly crank arm. Install the lock washers, spacers, and lock nuts as detailed in Figure 13 below.

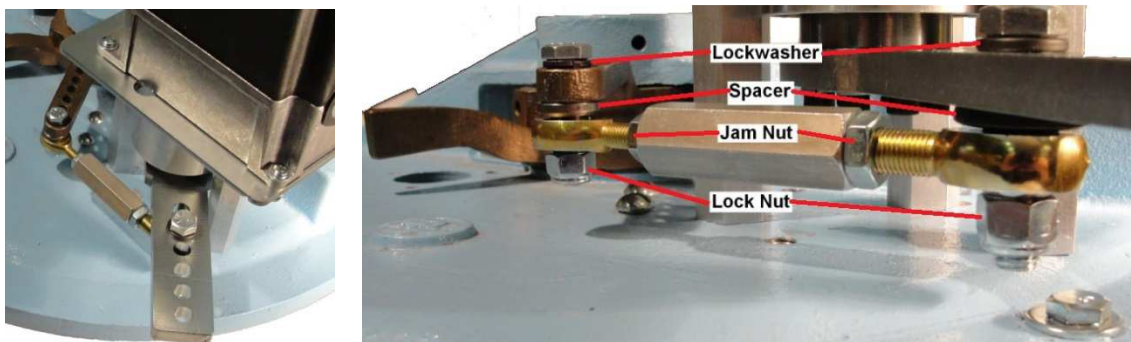

Figure 13: Turnbuckle Installation

13. After both the bolts that go through the crank arms are tightened, the hex piece (middle) of the turnbuckle assembly can be turned to adjust the position of the air damper crank arm relative to the bearing block assembly crank arm. After the turnbuckle is adjusted as desired, tighten both jam nuts against the hex piece to lock the turnbuckle adjustment. Also make sure that the set screws that hold the air damper crank arm (bronze-colored) to the air damper are tightened thoroughly.
14. If using an SQM45 or SQM48 actuator, skip this step. If using an SQM33 actuator, remove the fastener from the air damper that is utilized to stop the damper's movement from beyond closed as shown in Figure 14 below. **Note: This is a critical step because the SQM33 needs to reference beyond this point.**



Figure 14: Remove Mechanical Stop Screw for SQM33 Actuator

15. The mechanical installation is now complete, and should look similar to Figure 15. **Note: The travel on an SQM45 or SQM48 actuator from the air damper shut stop to the air damper open stop should be approximately 84-86 degrees.**

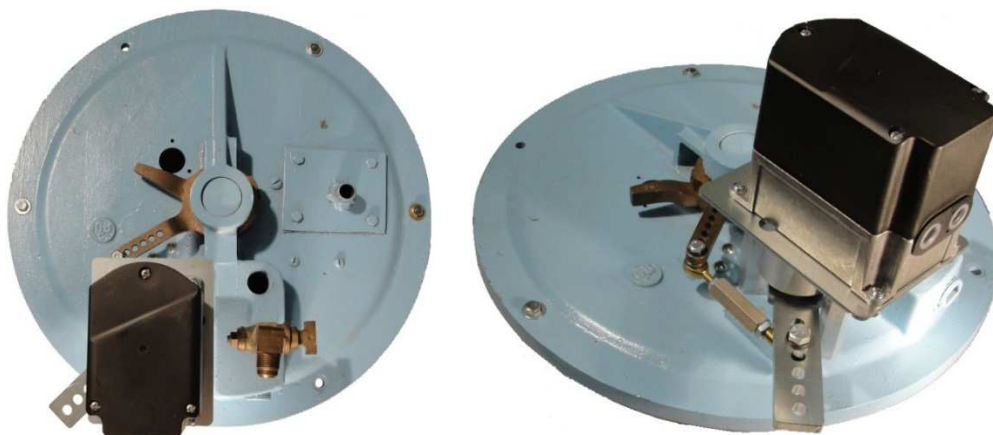

Figure 15: Completed Mechanical Installation

LMV Settings

LMV3

The following parameters must be set in the LMV3 to ensure the block arm can swing to reference the SQM33 actuator without bumping into the hex standoffs:

601.01: 0 (Air actuator will reference on closed side)

602.01: 0 (Air actuator will rotate counterclockwise when looking at the shaft)

If using an LMV36, the following additional parameters must be set for the second fuel:

608.01: 0 (Air actuator will reference on closed side – fuel 1)

609.01: 0 (Air actuator will rotate counterclockwise when looking at the shaft – fuel 1)

In addition, the SQM33 actuator can only travel approximately 85 degrees until the fully open stop is engaged. When setting purge positions and commissioning the fuel air ratio curve, do not set the air actuator position above 85 degrees.

LMV5

For proper rotation, the SQM45 or SQM48 actuator must turn counterclockwise when looking at the actuator shaft. This means that the air actuator must be set to standard rotation in the LMV5. This can be done through the following menu path:

Params & Display > Actuators > DirectionRot > AirActuator = **standard**

In addition, the SQM45 or SQM48 actuator can only travel approximately 85 degrees until the fully open stop is engaged. When setting purge positions and commissioning the fuel air ratio curve, do not set the air actuator position above 85 degrees.

Information in this publication is based on current specifications. The company reserves the right to make changes in specifications and models as design improvements are introduced. Product or company names mentioned herein may be the trademarks of their respective owners. © 2009 SCC Inc.