

## BR-N4-SQM33

---

### Product Description

The BR-N4-SQM33 NEMA 4 kit provides the shaft seal necessary to achieve a NEMA 4 seal on any SQM33... actuator.

---

### Product Part Numbers

**Table 1: Available SQM33... NEMA 4 Kit Part Numbers**

Part Number	Description
BR-N4-SQM33	NEMA 4 kit for an SQM33... actuator

---

### Components Supplied

Figure 1 shows the components supplied with a BR-N4-SQM33 NEMA 4 kit:

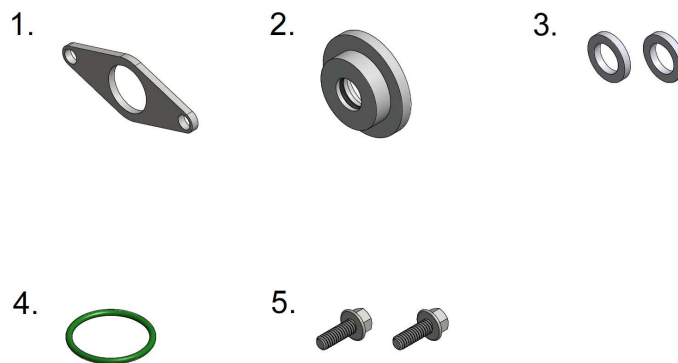

**Figure 1: Components Supplied with a BR-N4-SQM33 NEMA 4 Kit**

1. Seal retainer
  2. Shaft seal
  3. (2) #14 spacers
  4. Shaft seal O-ring
  5. (2) #14 x 3/4" thread-forming screws
-

---

## Recommended Installation Tools

The following tools are recommended for installing a BR-N4-SQM33 NEMA 4 kit:

- 3/8" nut driver or 3/8" socket with ratchet and extension

---

## Installation Procedure

1. Place the shaft seal O-ring into the annular groove on the back of the shaft seal. Then, slide the shaft seal over the actuator shaft as shown in Figure 2. Make sure that the shaft seal O-ring does not fall out of the annular groove when sliding the shaft seal over the actuator shaft.

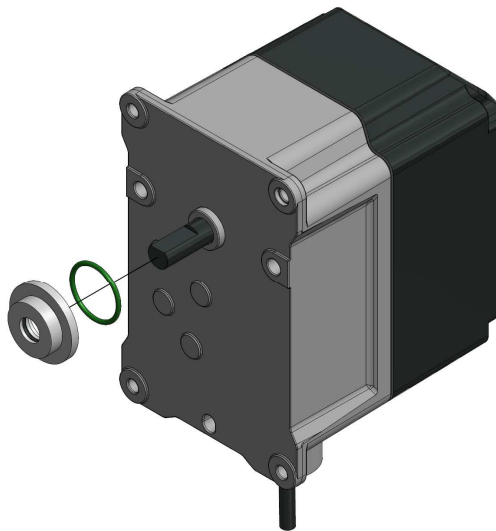
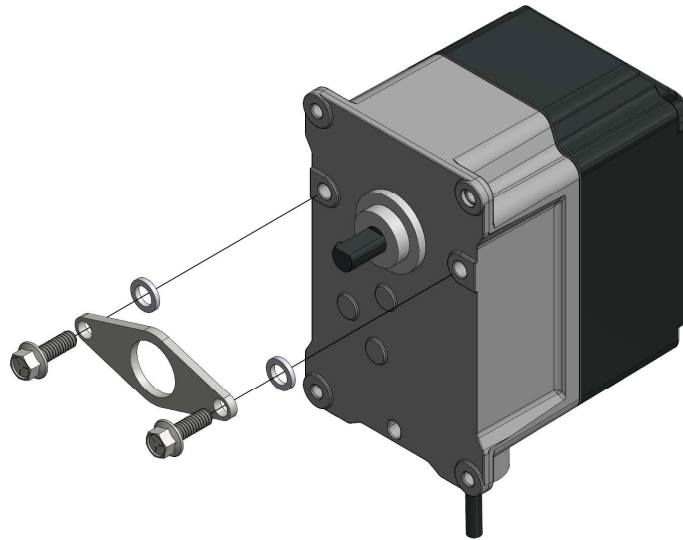

Figure 2: Shaft Seal Assembly

---

## Installation Procedure (continued)

2. Place a #14 x 3/4" thread-forming screw through each hole in the seal retainer. Slide a #14 spacer over the end of each #14 x 3/4" thread-forming screw. Slide the current assembly over the actuator shaft so that each #14 x 3/4" thread-forming screw lines up with one of the two holes in the bottom of the actuator as shown in Figure 3. The seal retainer should slide over the shoulder on the shaft seal. Using a 3/8" nut driver (or socket), tighten the two #14 x 3/4" thread-forming screws until the #14 spacers are captured between the seal retainer and the bottom of the actuator. **Do not overtighten the #14 x 3/4" thread-forming screws.**



**Figure 3: Seal Retainer Installation**

3. After the #14 x 3/4" thread-forming screws are tightened, the seal retainer will be slightly bent which is intentional in order to compress the shaft seal O-ring. At this point, the NEMA 4 kit installation is complete.

Information in this publication is based on current specifications. The company reserves the right to make changes in specifications and models as design improvements are introduced. Product or company names mentioned herein may be the trademarks of their respective owners. © 2009 SCC Inc.