

STANDARD CONFIGURATION DIMENSIONS 3 WAY DIRECT MOUNT

Instrument Mount Type	End Connection			HAM-LET Ordering Description	Dimensions											
					A		B		C		D		E		F	
	Process	Instrument	Vent / Bleed		mm	in	mm	in	mm	in	mm	in	mm	in	mm	in
Direct Mount	1/2" FNPT	*Flange	-	M-30A-15-8NF-SS-V-T	210.0	8.27	106.0	4.17	65.0	2.56	115.0	4.53	32.0	1.26	16.0	0.63
	*Flange	*Flange	-	M-30H-90-FF-SS-V-T	181.0	7.13	95.0	3.74	86.0	3.39	79.0	3.11	66.0	2.60	-	-

* Flange Standard per IEC 61518-A

M-30A-15-8NF-SS-V-T

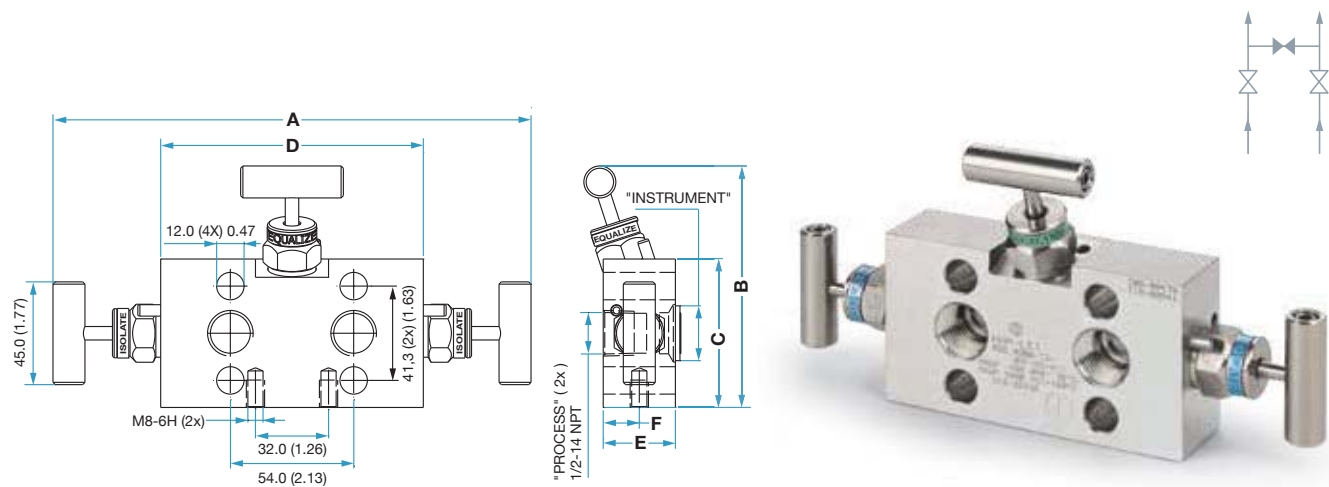

* Optimal vent / test ports

M-30H-90-FF-SS-V-T

