

Pressure Regulators

PF80-PF120



TECHNICAL MANUAL



PF80 & PF120

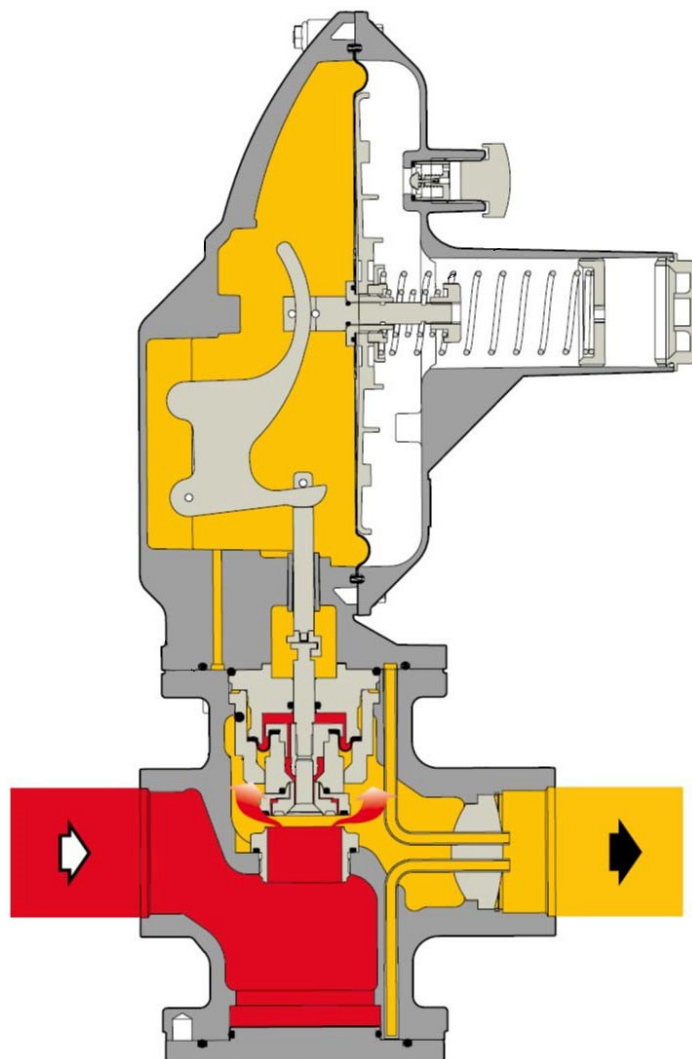

Basic version

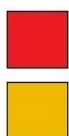

INLET PRESSURE

OUTLET PRESSURE



GENERAL WARNINGS

The regulator and accessories described in this manual are installed in systems under pressure and supply and control flammable gases (e.g. natural gas).

WARNINGS FOR THE INSTALLATION AND OPERATING PERSONNEL

Before performing the installation, start-up or maintenance, you must:

- review the safety procedures applicable to the installation site
- obtain the necessary training to operate and maintain the equipment, when required
- be equipped with the necessary personal protective equipment (helmet, goggles, etc.)
- make sure that the area where the equipment operates is equipped with the required safety equipment and has the necessary safety signs and notifications.

PACKAGING / TRANSPORT / STORAGE

The packaging materials used for transporting the equipment and the related spare parts have been designed and manufactured to avoid damages during normal transport, storage, and related handling. Therefore, the equipment and spare parts must be kept in their respective original packages until their installation in the destination site. When the packages are opened, it is necessary to verify the integrity of the materials therein contained. In case of damages, report the detected damage and please keep the original crate or box to allow the proper inspections of damages that may have occurred.

The storage of the equipment, even after its use, must occur in a moisture free environment and away from sources of light and within the temperature limits stated on the devices rating plate.

HANDLING

The handling of the regulator and its components must be performed using lifting means that are suitable for the weight to be lifted (lifting capacity and functionality) to avoid damage to the regulator such as bumps, impacts and local stresses.

When necessary, the handling of the regulator must be performed using the lifting points shipped with the equipment (lifting rings).

The use of motorized powered lift should only be operated by authorized personnel.

INSTALLATION

The installation of the pressure regulator must occur in compliance with company's codes, local codes and standards (laws or regulations) in force in the location of the installation.

Natural gas regulating stations must be designed and installed so they comply with the required laws or regulations in force in the place of installation. The installation must be in compliance with such standards minimizes the risk of fire and the formation of potentially hazardous atmospheres.

If the single regulator is not provided with built in overpressure protection devices, it must be installed making sure that the operating pressure of the installation in which it is installed does not exceed the value of the allowable maximum pressure (**PS**).

The user shall therefore, when he/she deems it necessary, provide for the installation on the assembly of suitable pressure limitation systems. Make sure you equip the station with suitable relief or bleed systems to be able to discharge the pressure and the gas contained in the station before proceeding with any inspection and maintenance.

Should the installation of the equipment require the installation on site of compression fittings and these should be installed following the instructions provided by the manufacturer of the fittings. The selection of the fittings must be compatible with the use specified for the equipment and with the plant specifications, when foreseen.

STARTUP (COMMISSIONING)

The startup must be carried out by **suitably trained personnel**.

During the startup, all personnel not required for the startup must be kept away and the area must be properly marked (signs, barriers, etc.).

Verify that the regulator and its accessory set points are the ones required and ordered from the factory. If necessary, you may need to adjust the required values as shown for later in this manual.

During the startup, there may be a risk of a discharge to the atmosphere of flammable or noxious gases must be reviewed.

For installation on natural gas distribution systems, it is necessary to consider the risk of formation of a (gas/air) explosive mix within the piping.

COMPLIANCE WITH ANSI B109.4 CERTIFIED BY CSA

The PF80 and PF120 regulators are certified according **ANSI B109.4**, regulators with size Max 1-1/4" NPT and Outlet Pressure 7" w.c. are in compliance with **CSA 6.18-02** and **ANSI B109.4**. For the other models and outlet pressure, all the tests were performed in reference to the **CSA 6.18-02** and **ANSI B109.4** standard.



1.0 INTRODUCTION

This manual is intended to supply essential information on the installation, startup, disassembly, re-assembly, and maintenance of the regulators **PF80** and **PF120**. The manual will also provide you with a brief description of the main features of the regulator and its accessories.

1.1 MAIN FEATURES

The pressure regulator **PF80** and **PF120** is a pressure regulator designed for filtered, cleaned gases. **PF80** and **PF120** are fail open regulators and will open in case of:

- Breakage of the main diaphragm, failure of the valve or seat assembly, damage to the lever mechanism
- Lack of set point pressure signal.

The main features of this regulator are:

- Design inlet pressure: up to 125 PSIG
- Ambient temperature: -20 °F to 150 °F (-28 °C to + 65 °C)
- Flowing gas operating temperature: -14 °F to 140 °F (10 °C to + 60 °C)
- Inlet pressure range: 5 to 125 PSIG
- Control head Maximum Outlet Pressure: PF80 10 PSIG, PF 120 5 PSIG
- Outlet pressure range: PF 80 7" w.c. - 10 PSIG, PF120 7" w.c. - 5 PSIG
- Accuracy class:
 - ✓ Fix Factor Billing (ANSI b109.4)
 - +2"/-1" w.c. with Set point ≤14" w.c.;
 - ±2" w.c. with 14" w.c. < Set Point < 1 PSIG
 - ±1% Abs with 1 PSIG ≤ Set Point ≤ 2 PSIG
 - ✓ General Application: ±10% Gauge

1.1.1 INTEGRAL STRAINER

All PF80 and PF120 models can be equipped with a removable built-in 300-micron strainer to prevent foreign particles, like welding slag or PE shavings, from entering the orifice and valve seat chamber and preventing lockup. The strainer also provides protection to all optional integral overpressure protection devices as well as downstream customer system. The strainer can easily be accessed without removing the regulator body from the piping, cleaned and replaced, if necessary.

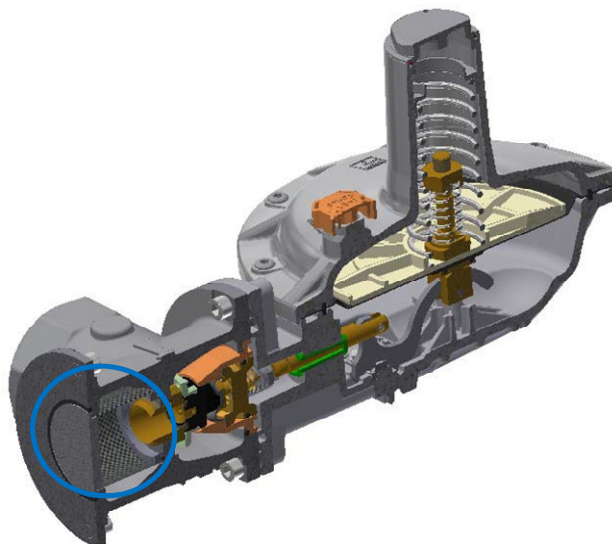

1.2 OPERATION OF THE CONTROL HEAD

Without pressure and with loaded setting spring, the valve (211) is kept in the open position by the connection of the stem (201) to the lever mechanism (305). The outlet pressure (P_d) is controlled by the comparison between the load of the spring (328) and the force that the outlet pressure exerts on the diaphragm (322).

The weight of the regulators components and inlet force acting on the valve are considered in the calculation of the balanced forces to operate the regulator. With this design as your inlet pressure changes it does not affect the balance of the valve (211), since the same - given the presence of the hole **A** - finds itself between two equal pressures acting on equal surfaces.

The movement of the diaphragm (322) controls the lever system (305) which is connected to the stem (201) and the valve (211). The valve is provided with a vulcanized rubber gasket to assure a perfect tightness with the flow rate is zero.

During operation when the outlet pressure (P_d) decreases, the force it exerts under the diaphragm (322) becomes lower than the load of the spring (328); causing the diaphragm to lower through the lever (305). The valve (211) to move away from the valve seat (102). Consequently, the gas flow rate increases until the initial set point pressure value is restored.

When the outlet pressure starts to increase, the force exerted on the diaphragm (322) exceeds the load of the spring (328). Then the valve is shifted toward the closed position, letting the outlet pressure return to the set point value. Under normal operating conditions, the valve (211) is positioned in such a way as to maintain the pressure (P_d) around the chosen set point value. The set point pressure can be adjusted by turning the internal spring adjustment nut (318) clockwise to increase the pressure and counterclockwise to decrease the pressure.

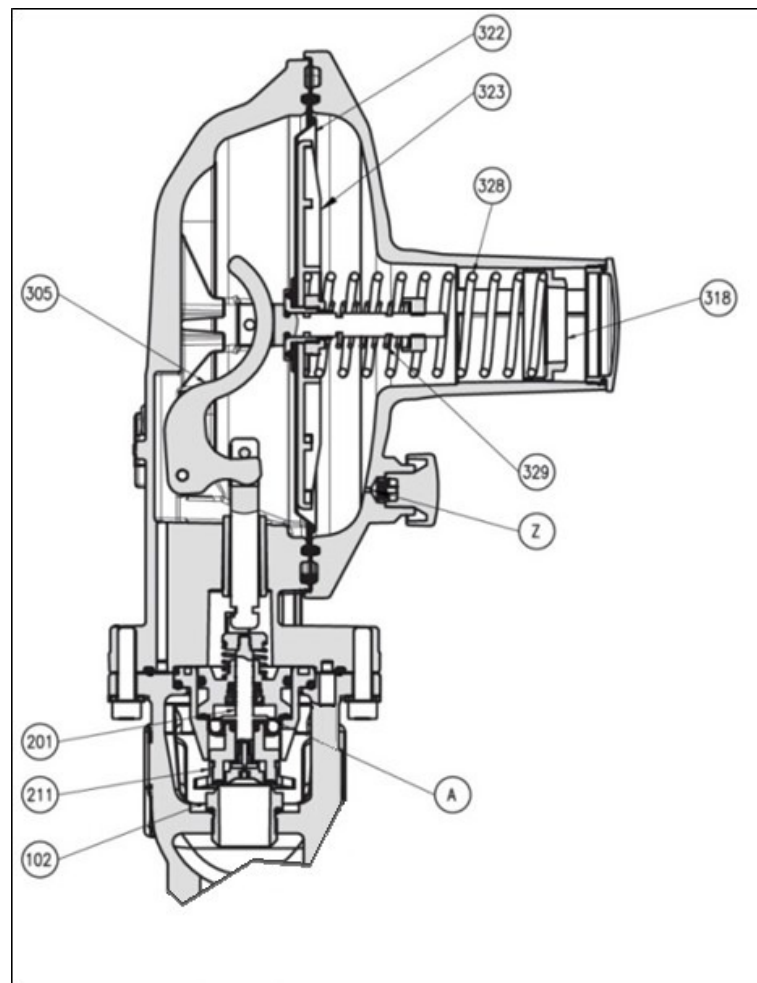

Figure 1: Control Head



TOKEN INTERNAL RELIEF VALVE (IRV)

The token IRV is shown in fig. 3. and is not a full relief device to be used as an OPP device. Its function is to protect the regulator against increases in the outlet pressure. This is used to relieve an increase in outlet pressure, such as thermal build up from sitting in the sun or from a quick acting on-off boiler, which may cause the slam shut to trip.

This token IRV diaphragm plate (323) is normally seated against the upper cover. If the set pressure increases to the set point of the IRV, it overcomes the load of the IRV spring (329), the IRV which opens the IRV valve, relieving the pressure caused by the abrupt pressure increase.

If the IRV is not needed it can be deactivated as shown in fig. 2 below. You will need to install 2 O-rings on the stem assembly to block the path of the gas deactivating the IRV.

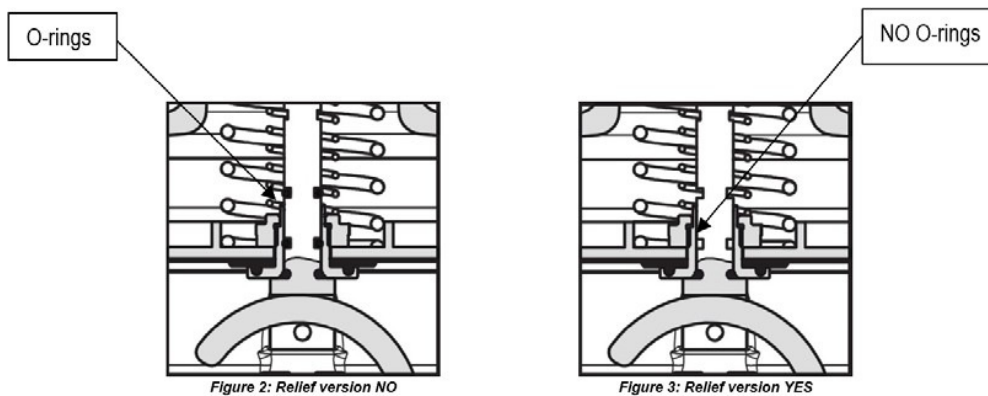

IRV setpoint above regulator set point

Worker Set point	IRV Set Point
≤ 20" W.C.	6-8" W.C.
>20" W.C.	20-24" W.C.

1.3 SET POINT SPRINGS FOR THE REGULATOR

Table 1.1 shows the set point ranges of the different available springs.

△

Control Head PF 120 Maximum Outlet Pressure = 7.25 PSIG, PF 80 head is 10 PSIG. In case of a single regulator supplied without built in overpressure Pietro Fiorentini protection device (SSV, IMD or IFM), the regulator shall be protected with a secondary means of overpressure protection per does DOT §192.740 & NFPA 54 5.9.3.1 standard. The over pressure protection must be provided per code capable of limiting the downstream pressure to the system.

SPRINGS FOR PF 120			
Code	Color	Head	Pressure Range
US64470382NE	BLACK	BP	7" – 11" w.c.
US64470301GI	YELLOW	BP	12" – 16" w.c.
US64470302VI	VIOLET	BP	0.6 – 1.2 PSIG
US64470262AR	ORANGE	MP	1.3 – 2.4 PSIG
US64470398AZ	LIGHT BLUE	MP	2.5 – 4.2 PSIG
US64470408RO	RED	MP	4.3 – 5 PSIG

SPRINGS FOR PF 80			
Code	Color	Head	Pressure Range
US64470068GI	YELLOW	BP	6.8" – 9.6" w.c.
US64470139NE	BLACK	BP	10" – 14.1" w.c.
US64470071GR	GREY	BP	0.9 – 1.5 PSIG
US64470141VE	GREEN	MP	1.5 – 2.4 PSIG
US64470329AZ	LIGHT BLUE	MP	2.5 – 5.3 PSIG
US64470144VI	VIOLET	TR	5.4 – 10.2 PSIG

2.0 INSTALLATION

2.1 GENERAL

Before installing the regulator, it is necessary to make sure that:

- the regulator can be inserted in the existing space provided and provides sufficient area for performing maintenance operations (see overall dimensions in table 2.1)
- the inlet and outlet piping is level and aligned and can support the regulator weight (see table 2.2)
- the inlet/outlet connections of the regulator are clean from any residual impurities such as welding scraps, sand, paint residues, water, etc
- the regulator itself has not been subject to any damages during transport

The recommended installations are shown in fig. 4.

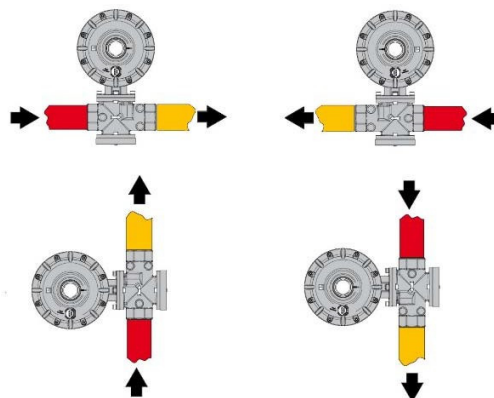

Figure 4



Table 2.1: Overall dimensions in inches (fig. 6)

Code	DN	A*	B**	C**	D	E	F	M	N
PF80 basic	1-1/4"; 1-1/2"; 2" NPT	6.6"	10.2"	2.6"	7.3"		7.0"	1/4"	
PF80 IMD	1-1/4"; 1-1/2"; 2" NPT	6.6"	10.2"	4.25"	7.3"		7.0"	1/4"	
PF80 IFM	1-1/4"; 1-1/2"; 2" NPT	6.6"	10.2"	10.3"	7.3"		7.0"	1/4"	
PF80 SSV	1-1/4"; 1-1/2"; 2" NPT	6.6"	10.2"	8.2"	7.3"	6.5"	7.0"	1/4"	1/4"
PF120 basic	2" NPT	7.6"	15.4"	3.9"	11.0"		10.1"	1/2"	
PF120 IMD	2" NPT	7.6"	15.4"	6.1"	11.0"		10.1"	1/2"	
PF120 IFM	2" NPT	7.6"	15.4"	15.5"	11.0"		10.1"	1/2"	
PF120 SSV	2" NPT	7.6"	15.4"	9.5"	11.0"		10.1"	1/2"	1/4"

* Flanged version: A dimension equal to 10"

** Disassembling requires 3" more than overall dimension on PF120 and 2" on PF80, except in case of blind flange

Table 2.2: Weights in pounds

Code	Basic	IMD	IFM	SSV
PF80 1-1/4"; 1-1/2"; 2"	13.5	18.1	18.1	14.8
PF120 2"	26.0	36.4	36.4	27.6
PF120 2" flanged	34.8	45.2	45.2	36.4

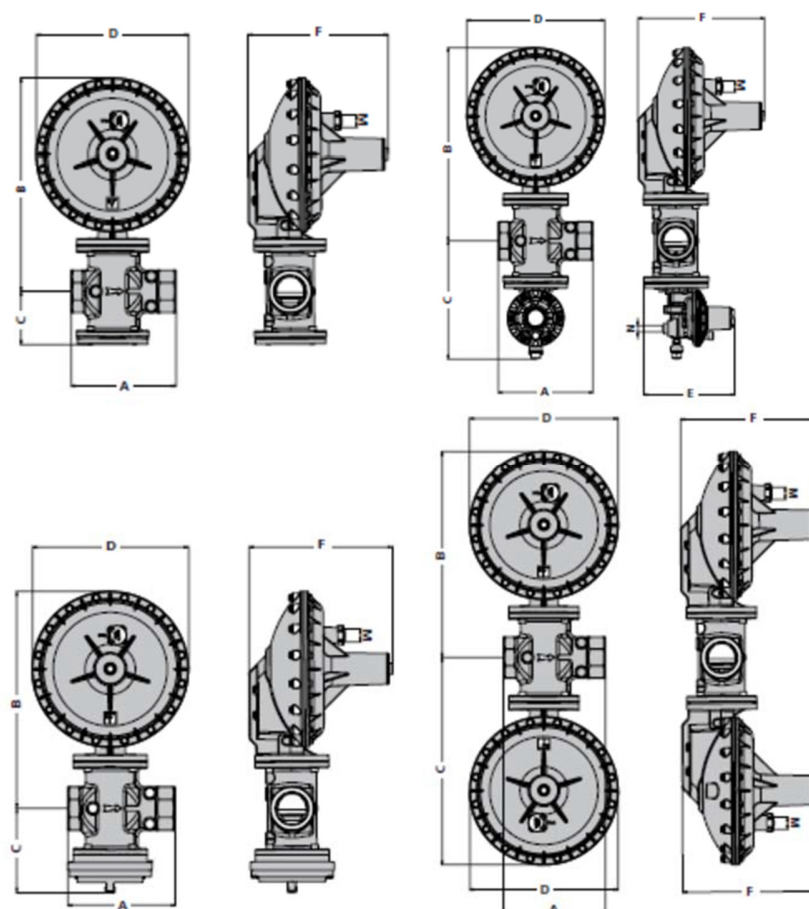

Figure 6: Overall dimension



2.2 CONNECTING THE EQUIPMENT

The Pietro Fiorentini regulators series can be equipped with:

- internal sensing line
- external sensing line
- external sensing line (monitor version)

The connections between the equipment and the piping have to be carried out using a stainless-steel tubing, having a minimum diameter of 3/8" OD.

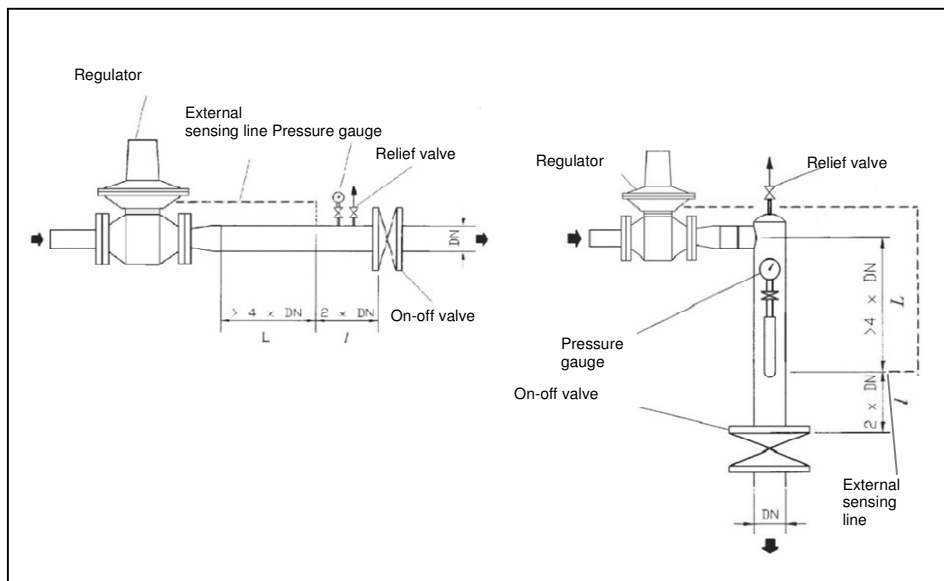

Figure 7: Installation diagram

The regulator must be installed in the line the arrow is position on the body in the direction of the gas flow. To obtain a good regulation set point, it is essential that the position of the outlet pressure sensing points and the gas speed at the sensing point meet the values given in table 2.3.

The single regulator must be protected from over pressurization with a built in or a secondary protection device.

To prevent impurities and condensation from building up in the pressure sensing tubes, please make sure of the following:

- the tubing must always be positioned on a descending slope towards the connection of the outlet piping, with a slope of about 5 - 10%;
- tubing tapped connections are always to be welded on the upper part of the piping itself and be a minimum of 1/2" and the hole on the piping shall not show any burrs or projections towards the internal side. Use full port ball valves if valves are installed in the sensing lines.

To avoid breaking the pipe or regulator, it is recommended to provide for the following:

- the equipment shall be installed with all codes in force and the good piping practices
- the equipment shall be supported properly with no external loads acting on the regulator
- the equipment shall be provided with adequate protection and grounding means to protect it against stray currents and electrostatic potential differentials
- the equipment shall be used within the pressure limitations indicated on the rating plate

FOR OPTIMAL PERFORMANCE, gas speed should not exceed the following values:
$V_{max} = 82 \text{ ft./s}$ for $21.75 < P_d < 72.50 \text{ PSIG}$
$V_{max} = 65 \text{ ft./s}$ for $7.25 < P_d < 21.74 \text{ PSIG}$
$V_{max} = 49 \text{ ft./s}$ for $P_d \leq 7.24 \text{ PSIG}$

Table 2.3



3.0 MODULARITY

The modular concept of the PF80 - PF120 series allows the possibility of installing the following optional accessories (IMD, IFM, SSV) to the same body, even after the installation of the regulator.

3.1 SLAM-SHUT VALVE (SSV)

The SSV is a device (fig. 8) that can be configured for over pressure shut off (OPSO). The SSV immediately shuts off the gas flow when a pressure failure occurs and when the outlet pressure reaches the set point for its tripping.

The PF80 - PF120 slam-shut valve is normally installed on the monitor or single regulator applications. The SSV gives the customer the possibility to have the slam-shut valve installed on both the worker regulator and on the one acting as monitor in line.

The following are the main characteristics of this slam-shut device:

- Allowable maximum inlet pressure: up to 125 PSIG
- Tripping due to pressure increase
- Accuracy up to $\pm 5\%$ on the set point value for pressure increase (depending on the set point pressure)
- Internal bypass device, which allows easy resetting of the slam shut

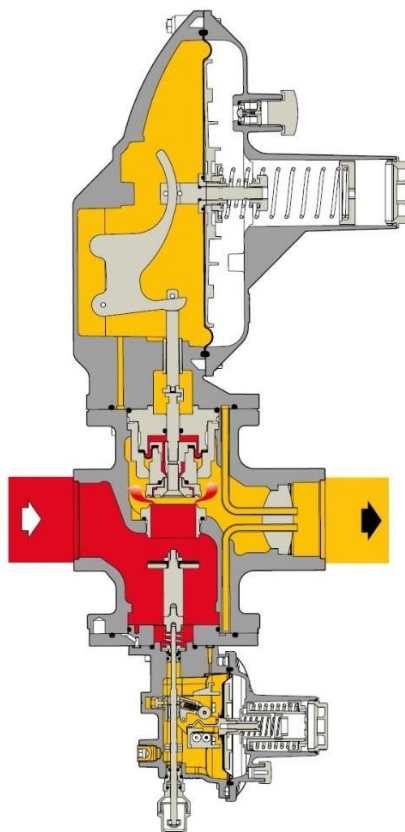

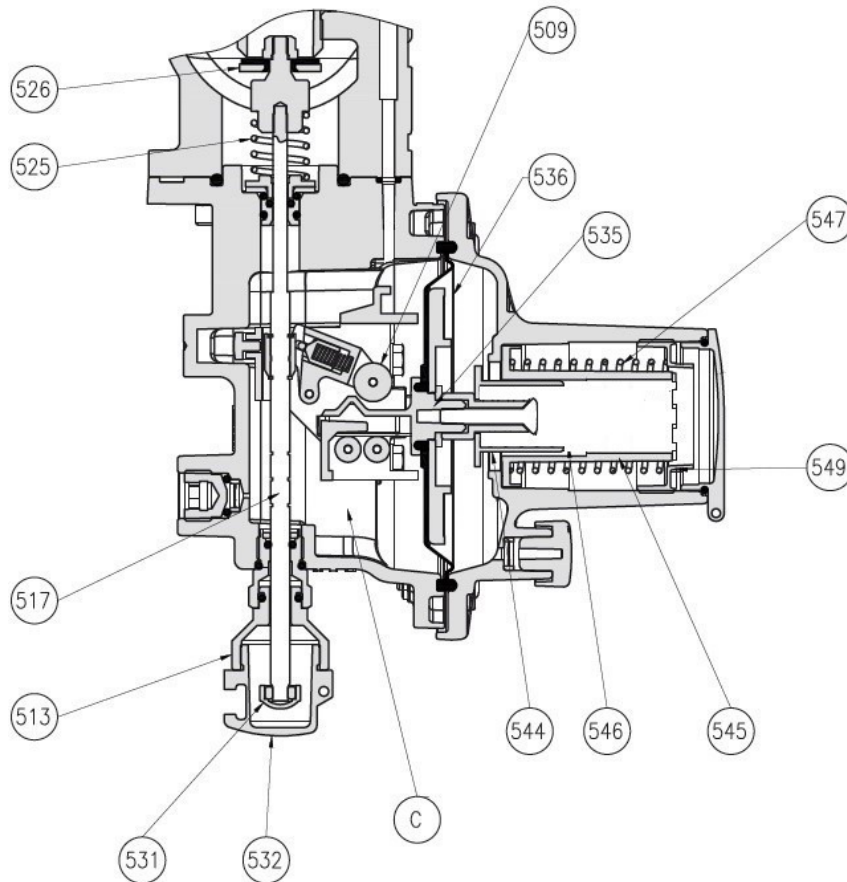

Figure 8: Slam-Shut Device LA

The slam-shut valve /LA (fig. 8), is essentially made up of a valve mounted on a stem, a release lever mechanism, a control head and a manual reset system. In chamber **C** of the control head, the set point pressure to be controlled (**P_d**) acts on the diaphragm (**536**), which is connected with the shaft with cam (**535**). The control pressure (**P_d**) on the diaphragm is opposed by the setting springs (**547**), which cause the tripping due to increase in the pressure. The set point of the device is performed by acting on the adjustment nut (**549**). A clockwise rotation of the nut results in an increase in the set point tripping value and counterclockwise rotation decreases the set point tripping value.

In the case of tripping due to pressure increase, when the set point pressure (**P_d**) exceeds the set point value, the load on the diaphragm (**536**) increases until it overcomes the resistance of the spring (**547**). This causes the movement of the shaft (**535**) cam then moves the cam roller (**509**) thus releasing the lever mechanism. In this way, the stem (**517**) is freed and the valve (**526**) is made to close by the spring (**525**).

Resetting of the switch must be done manually. To reset the slam-shut, your pressure must be between the maximum and minimum set point of the switch. Resetting occurs by pulling the reset knob (**531**) until the lever mechanism is coupled again.

It is necessary to wait until the upstream pressure passes downstream of the valve - through the internal bypass and balances it. After restoring the reset knob (**513**), it must be press-fit into its seat to make it water tight.

The opening or closing status of the slam-shut valve is detectable from outside by observing the position of the green colored cap (**531**) through the plug (**532**). If the green button is out, the slam shut is armed and if the green button is in, the slam shut is tripped.



3.1.1 SET POINT SPRINGS OF THE SLAM-SHUT DEVICE LA/... AND IFM AND SSV RECOMMENDED SETTINGS:

Table 3.1 shows the tripping ranges available for the pressure switches.

FEATURES OF THE SPRINGS FOR SSV FOR PF80 – PF120			
Code	Color	Head	Pressure Range
US64470112RO	RED	BP	14" – 20" w.c.
US64470115GR	GREY	BP	0.7 – 2.5 PSIG
US64470116GI	YELLOW	MP	2.6 – 3.9 PSIG
US64470057BL	BLUE	MP	4.0 – 7.0 PSIG
US64470051BI	WHITE	TR	7.1 – 11.9 PSIG*
US64470057BL	BLUE	TR	12.0 – 17.0 PSIG*

*only SSV PF80

Table 3.2 shows the recommended settings

PF80 SSV/IFM SETTING RULES		
Range	Min SSV Set	Min IFM Set
6.8" – 9.6" w.c.	Set Point x 2	Set Point +3" w.c.
10"– 14.1" w.c.	Set Point x 1.8	Set Point +3" w.c.
0.9 – 1.4 PSIG	Set Point x 1.5	Set Point x 1.2
1.5 – 2.4 PSIG	Set Point x 1.5	Set Point x 1.2
2.5 – 5.3 PSIG	Set Point x 1.5	Set Point x 1.2
5.4 – 10.2 PSIG	Set Point x 1.5	Set Point x 1.1

PF120 SSV/IFM SETTING RULES		
Range	Min SSV Set	Min IFM Set
7" – 11" w.c.	Set Point x 2	Set Point +3" w.c.
12"– 16" w.c.	Set Point x 1.8	Set Point +3" w.c.
0.6 – 1.2 PSIG	Set Point x 1.5	Set Point x 1.2
1.3 – 2.4 PSIG	Set Point x 1.5	Set Point x 1.2
2.5 – 4.2 PSIG	Set Point x 1.5	Set Point x 1.2
4.3 – 5.0 PSIG	Set Point x 1.4	Set Point x 1.1

3.2 INDEPENDENT MONITOR DEVICE (IMD)

The IMD (fig. 9) is an effective overpressure protection safety device designed to limit downstream pressure build-up in case of regulator seat failure or other catastrophic failure such as a cut diaphragm or lever disconnect. During normal operation, when the control head working with the outlet pressure set point (**P_d**), the valve (**51**) is kept in the open position by the setting spring (**20**) load.

In the event of a regulator failure, the IMD operates on the inlet side or the orifice to limit downstream pressure. Since the IMD is a separate and independent device from the main regulator, it can function in the event of a catastrophic failure on the main regulator. In this case, the outlet pressure (**P_d**) is controlled by the comparison between the load of the setting spring (**20**) and the force that the outlet pressure itself exerts on the diaphragm (**11**). The inlet pressure, even though it may change, does not affect setting because of the valve (**51**) is balanced by the force of the balancing piston valve (**54**). This equal force operates the valve system of the IMD.

If during IMD operation the set point pressure (**P_d**) decreases, the force it exerts on the diaphragm (**11**) becomes lower than the load of the spring (**20**); therefore, the diaphragm lowers, causing the valve (**51**) to move away from the valve seat. Then the gas flow rate increases until the initial set point pressure value is restored.

If instead the outlet pressure starts to increase, the force exerted on the diaphragm (**11**) exceeds the load of the spring (**20**) and the valve is shifted toward the closed position, letting the outlet pressure return to the preset value. We can observe during operation, that a small amount of gas will bleed to the atmosphere when the IMD is functioning or in lock-up and alert about the OPP. This is possible because, when valve (**51**) moves in working position, stem (**51**) moves together and separates from valve (**61**). Gas flows through an internal hole on stem (**51**) and then bleeds to the atmosphere through the flange (**12**) vent hole. A little orifice (**67**) guarantees that gas bleeding will be smaller than 1 cubic feet per hour with OPP ≤ 2PSIG and smaller than 2,5 scfh with OPP greater.

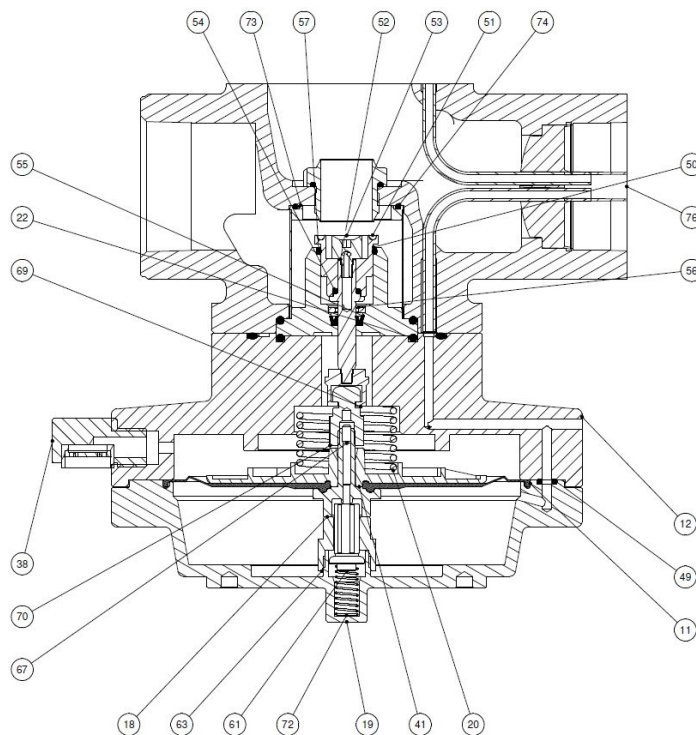

Figure 9: Independent Monitor Device IMD

FEATURES OF THE SPRINGS FOR IMD	
<i>Regulator Set-point</i>	<i>IMD Guaranteed Max Outlet Pressure</i>
7" w.c.	1 PSIG
7" w.c. - 1 PSIG	2 PSIG
7" w.c. - 2 PSIG	5 PSIG
7" w.c. - 5 PSIG	7 PSIG



3.3 PF80 & PF120 WITH MONITOR OPERATION

PIETRO FIORENTINI has a solution for installations where an in line monitor regulator is required. The monitor is an emergency regulator which will take over control of the pressure in the event that the worker regulator fails.

3.3.1 FEATURES

PF80 & PF120 with monitor has the internal control line blocked and uses an external control line to sense the operating pressure. The external control line tap is a standard feature of the regulator that comes plugged in the standard version.

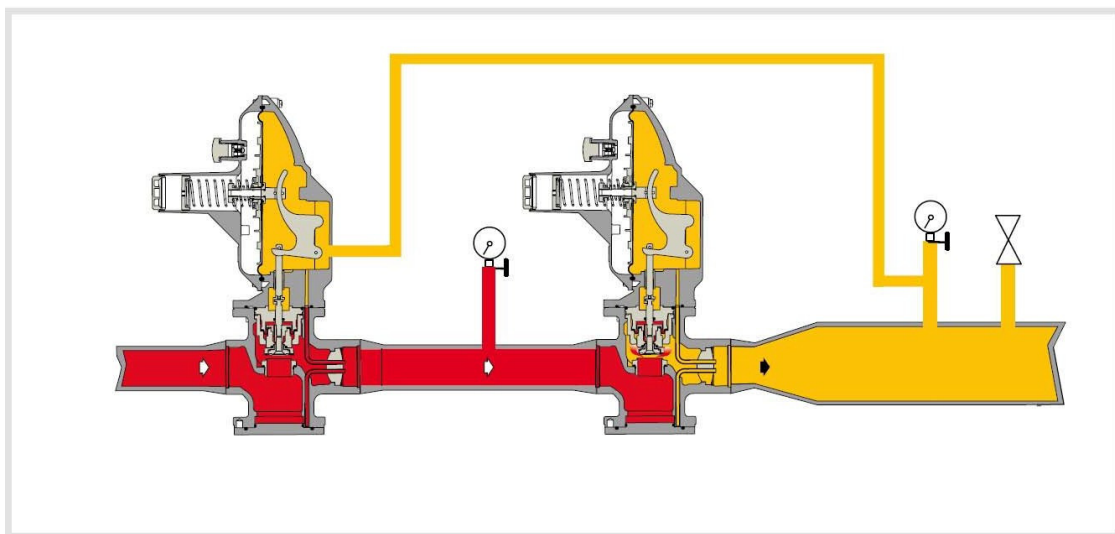

4.0 START UP

4.1 START UP

After the installation, verify that the shut off valves at inlet and outlet and any available bypass valves are closed. Before start up, it is recommended to verify that the regulator meets the ratings for the design of the station. The regulators identification plate has all the necessary information regarding the regulator (fig.10).

WARNING: You must open and close the inlet and outlet valves slowly. Opening the valves too fast may damage the regulator.

EQUIPMENT RATING PLATES



Figure 10: Equipment rating plate

5.2 PRESSURIZING, CHECKING FOR LEAKS, AND ADJUSTMENT

Pressurizing the equipment must be performed very slowly. It is highly recommended to keep the gas speed in the feed piping under a value of 15 ft./sec during the pressure feeding phase. The regulator is designed to regulate pressure from the inlet to the outlet and should always be **pressurized from the inlet** and **depressurized from the outlet**. To prevent the equipment from being damaged, the following shall be absolutely avoided:

- Pressurization through a valve on the outlet of the regulator.
- Depressurization through a bleed valve positioned on the inlet side of the regulator.

When checking for leaks, either use a portable gas detector or apply a liquid leak detector on the regulator and piping under pressure and make sure no bubbles are produced. The regulator and any accessories are normally supplied already set from the factory to the required value. Due to several reasons (e.g. vibrations during transport) the set points may be subject to slight changes. It is advisable to verify the set points according to the procedures outlined below.

In installations consisting of parallel runs, it is recommended to start up one line at a time, starting from the one with the lower set point value, i.e. the so-called "spare", "backup" or "standby" line.

Before starting the regulator, it is necessary to verify that all on-off valves (inlet, outlet, and bypass - if any) are closed and that the gas is at working temperature as not to create malfunctions.

5.3 START UP OF THE REGULATOR AND REGULATOR WITH INDEPENDENT MONITOR DEVICE (IMD)

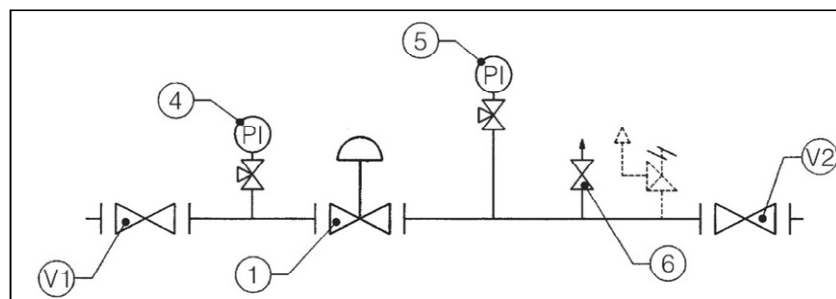

Figure 11: Diagram (internal sensing line)

1. Slightly open the bleed valve 6 located on the outlet piping;
2. Very slowly, open the inlet on-off valve V1;
3. Once the inlet and outlet pressure values have stabilized, using the pressure gauge 5, check that the outlet pressure shows the desired set point value. Should this not be the case, adjust the set point and adjust the value;
4. Close the bleed valve and check the lockup of the regulator and the value of its lockup overpressure;



5. Use a liquid leak detector, check the tightness of all the joints present between the on-off valves V1 and V2;
6. Very slowly open the outlet on/off valve V2 until reaching the complete filling of the piping.

If a relief valve is installed in the system, refer to par. 4.1 to check it.

5.4 START UP OF THE REGULATOR AND REGULATOR WITH INDEPENDENT MONITOR DEVICE (IMD) OR INDEPENDENT FULL MONITOR (IFM)

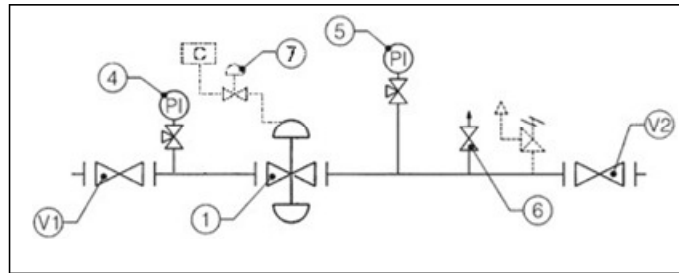

Figure 12: Diagram (internal sensing line)

5.4.1 START UP

1. Slightly open the bleed valve 6 located on the outlet piping;
2. Very slowly, open the inlet on-off valve V1;
3. Once the inlet and outlet pressure values have stabilized, using the pressure gauge 5, check that the outlet pressure shows the desired set point value. Should this not be the case, adjust the set point and adjust the value;
4. Close the bleed valve and check the lockup of the regulator and the value of its lockup overpressure;
5. Using a liquid leak detector, check the tightness of all the joints present between the on-off valves V1 and V2;
6. Very slowly open the outlet on/off valve V2 until reaching the complete filling of the piping.

5.4.2 CHECKING IMD/IFM SET POINT

IMD and IFM check point shall be carried out using one of following procedures:

Procedure A

1. Connect a pressure source C to workers vent connection.
2. Very slowly close V2, slightly open bleed valve 6.
3. Increase Pressure 7 until the IMD /IFM reaches set point adjusting the bleed 6 if necessary
4. Check monitor or IMD set point.
5. Close the bleed valve and check the lockup of the IMD/IFM regulator and the value of its lockup pressure;
6. Very slowly decrease Pressure 7 and Disconnect pressure source C and check worker pressure and lock up.
7. If the pressures are satisfactory very slowly open the outlet on/off valve V2 and put the regulator back in service.

Note: This procedure inhibiting the anti-hunting valve located on worker vent. Make sure to use a small pressure bleed 6 in order to avoid instability.

Procedure B

1. Very slowly close V2
2. Use the existing main spring if it can go above monitor set point or remove the main spring and replace the main spring with one that can go above monitor set point.
3. Slightly open bleed 6.
4. Increase the worker pressure until the IMD /IFM reaches set point adjusting the bleed 6 if necessary
5. Check monitor or IMD set point.
6. Close the bleed valve 6 and check the lockup of the IMD/IFM regulator and the value of its lockup pressure;
7. Lower the worker pressure or remove the replacement spring and install the original worker spring pressure source using 6 bleed valve and check worker pressure and lock up.
8. If the pressures are satisfactory very slowly open the outlet on/off valve V2 and put the regulator back in service.

5.5 CHECKING THE SLAM-SHUT VALVE LA AND START UP OF THE REGULATOR WITH SLAM-SHUT VALVE LA/...

Check and record the tripping of the Slam-shut device 7 as follows:

- A. For slam-shut devices with internal sensing line proceed as follows:

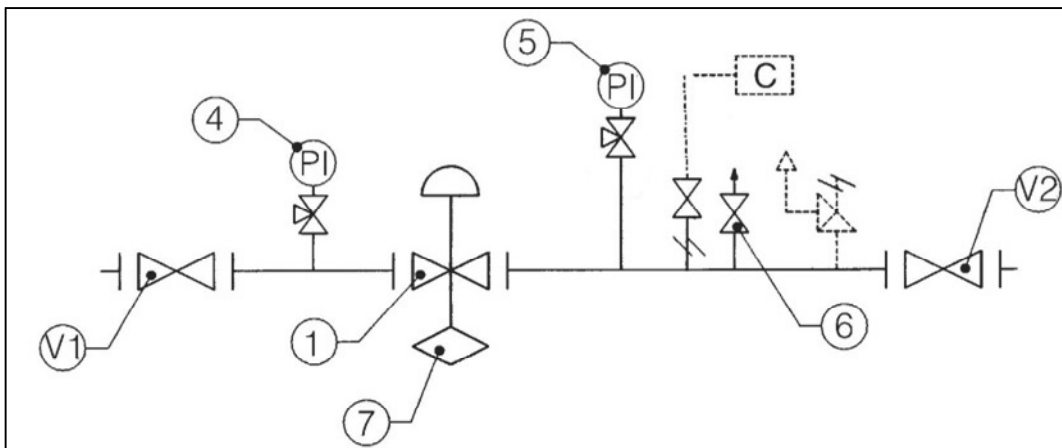

Figure 13: diagram (internal sensing line) with embedded slam-shut valve (internal sensing line)

1. Connect a controlled test pressure C downstream;
2. Stabilize this pressure at the set point value set for the regulator;
3. For safety devices that trip in case of maximum pressure: slowly increase the test pressure and verify the tripping value. If necessary, increase the tripping value by rotating clockwise the adjustment ring nut (549); rotate it counterclockwise to decrease the tripping value.



NOTE:

- If there is an external relief valve, bypass such device before checking the slam-shut device.
- If there is an internal relief valve, either bypass such device before checking the slam-shut device or connect a controlled auxiliary pressure with a flow rate greater than that of the relief device.
- It is recommended to repeat the tripping tests **during your normal inspection period.**

At the end of the slam-shut device check operations, proceed as follows:

- Make sure that the slam-shut device is in closed position
- Open the inlet on-off valve V1
- Very slowly open the slam-shut valve, by pulling the proper bushing
- Partially open the bleed valve 6 on the outlet piping
- Using the pressure gauge 5, check that the downstream pressure has the desired set point value for the regulator. Should this not be the case, adjust the set point by adjusting on the spring ring nut, turning it clockwise to increase and counterclockwise to decrease the value
- Close the bleed valve 6 and check the lockup pressure value
- Using a liquid leak detector, check the tightness of all the joints present between the on-off valves V1 and V2
- Very slowly open the outlet on-off valve V2 until reaching the complete filling of the piping



6.0 TROUBLESHOOTING

Some of the operational problems that may occur from time to time are described below. These are problems linked to gas conditions, as well as to the natural aging and wear of the regulator components.

Please note that all service on the equipment **must be performed by technically qualified personnel having suitable training on the equipment.**

The tampering and improper use of the equipment by non-qualified personnel relieves Pietro Fiorentini SpA from any liability whatsoever.

6.1 PROBLEMS WITH THE REGULATOR

Table 6.1 describes the possible anomalies that the regulator may show.

INCONVENIENCE	POSSIBLE CAUSES	INTERVENTION
Lack of lockup at Q=0	Valve seat [102] damaged	Replacement
	Valve [211] damaged	Replacement
	O-rings damaged	Replacement
	Membrane [322] damaged	Replacement
	Dirt or foreign bodies in the sealing area	Cleaning
Set point hunting (pumping)	Abnormal frictions in the stem-valve assembly [305]	Cleaning and replacement, if necessary, of the sealing and/or guide elements
	Reduced volumes downstream	Increase in the volume
Increase of set point with Q>0	Breakage of the diaphragm [322]	Replacement

6.2 PROBLEMS OF THE SLAM-SHUT DEVICE LA/...

Table 6.2 describes the possible problems that the slam-shut device may show.

INCONVENIENCE	POSSIBLE CAUSES	INTERVENTION
The Slam-shut valve does not close	Breakage of the diaphragm [536] of the measuring head	Replacement
Leak from the slam-shut valve	Valve gasket [526] deteriorated	Replacement
	Valve seat eroded or scratched	Replacement
Wrong release pressure	Wrong set point of the max. spring	Perform the set point again by acting on the ring nuts [549] and/or [549]
	Lever mechanisms subject to friction	Change the box containing the entire assembly
It is not possible to perform reset	The cause, which led to the pressure increase or decrease downstream, persists	Let downstream pressure drop or increase it
	Broken or splintered lever mechanisms	Change the standard box containing the assembly outside the regulator

NOTE. If the slam-shut valve tripped, first close the inlet and outlet valves (V1 and V2) of the line and discharge the pressure. Solve the problem, which led to the tripping before restarting the equipment.

In case of malfunctions where there are no qualified technicians available for the specific repair, contact our customer service center nearest to you.



6.3 PROBLEMS OF THE INDEPENDENT MONITOR DEVICE (IMD)

INCONVENIENCE	POSSIBLE CAUSES	INTERVENTION
Leakage at Q=0	Valve seat [102] damaged	Replacement
	Valve [211] damaged	Replacement
	O-rings damaged	Replacement
	Diaphragm [322] damaged	Replacement
	Dirt or foreign bodies in the sealing area	Cleaning
Bleeding gas without Over Pressure event	Valve [61] damaged	Replacement
	Seat of stem [18] damaged	Replacement
	Flange [12] and [19] not completely closed	Fasten screws [71]
Over Pressure event without bleeding gas	Orifice [67] blocked	Cleaning and/or Replacement
Set point hunting (pumping)	Abnormal friction in the stem-valve assembly [51]	Cleaning and replacement, if necessary, of the sealing and/or guide elements
	Reduced volumes downstream	Increase in the volume
Increase set point with Q>0	Breakage of the diaphragm [11]	Replacement



7.0 MAINTENANCE

7.1 GENERAL

Maintenance, inspection, and operation must be carried out in compliance with all company safety regulations in force at the site of the installation of the equipment. Before performing any kind of service, it is important to ensure that the slam-shut valve (if installed) has been closed, that the inlet & outlet isolating valves have been closed and that all the pressure has been discharged from the piping between the slam-shut valve and those isolating valves.

Maintenance services are dependent on the quality of the gas (impurities, humidity, gasoline, corrosive substances) and to the filtration efficiency of the system.

It is always recommended to perform preventive maintenance inspections according to the following conditions, unless specified by your company's regulations in force:

- The quality of the flowing gas;
- The condition and cleanliness of the piping upstream of the regulator as a rule, for example, after the first start of the stations. More frequent maintenance may be required due to uncertain internal cleanliness of the piping;
- The reliability level required by the regulator station.

Before disassembling the regulator, make sure:

- To have a series of original spare parts available. Spare parts shall be original spare parts provided by Pietro Fiorentini.
- To have a set of tools as shown in table 7.5.

For proper maintenance, the recommended spare parts are identified by numbered tags that match the drawing in the box:

- The parts layout drawing number of the component and where they are used;
- The position given on the parts layout drawing of the equipment. It is suggested to replace all rubber parts and use the correct spare part kit available from a Pietro Fiorentini distributor or website.

NOTE. The use of non-original parts relieves Pietro Fiorentini S.p.A. from any responsibility.

When depressurizing, pay attention to discharge the bleed gas to a safe area and avoid risks related to the formation of sparks due to impurity particles inside the discharge lines is recommended to keep gas speed lower than 16 ft./sec.

It is suggested to put reference marks on the regulator components before disassembling so those parts that can be positioned or oriented correctly during re-assembly. Finally, please make sure a thin layer of silicone grease has been applied to all O-rings and the sliding mechanical parts (stems, etc.) before reassembling.

Before start up, it is necessary to verify there are no leaks in the system at a suitable test pressure, then also check there are no leaks at full operating pressure. This includes slam-shut devices and monitors when they are used as safety devices at the maximum working pressure. These checks are essential to assure the safe use of the regulator station's equipment at the intended operating conditions and that they shall comply with the all regulations in force.

When necessary, the Internal Strainer may be cleaned without removing the regulator from the line. Proceed as follows:

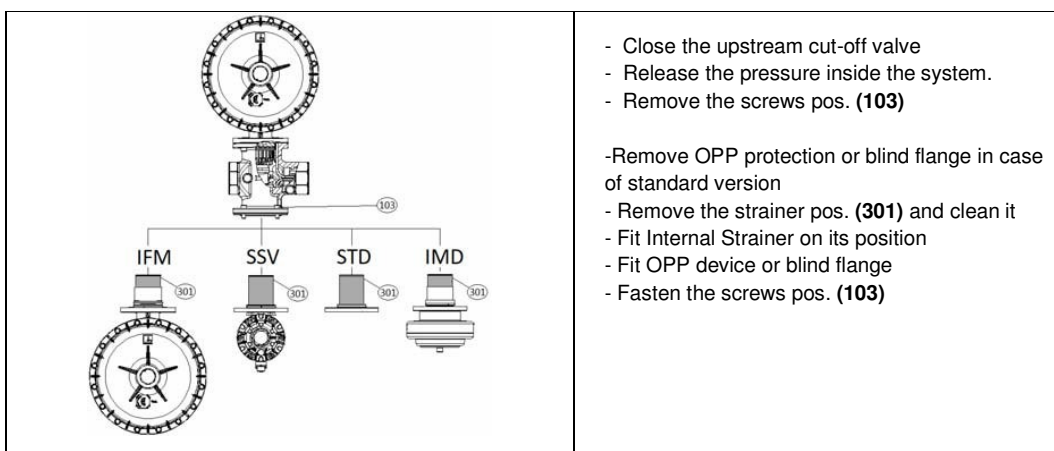



8.0 FINAL OPERATIONS







8.1 LOCK UP, LEAKAGE AND SET POINT CHECK

1. Leave the outlet valve closed
2. Very slowly, open the inlet valve at the inlet of the regulator and,
3. At regulator outlet, open a bleed valve able to create a small gas flow rate
4. Operating very slowly, pull the bushing of the slam-shut valve until opening only the internal bypass. Then when pressure has equalized, pull until the coupling is latched position
5. Check the lockup of the valve of the regulator
6. using potable gas detector or applying a liquid leak detector
 - Leakage of the regulator external surfaces
 - Leakage of the slam-shut valve
 - Leakage of the regulator internal surface
7. At regulator outlet, open a bleed valve able to create a small gas flow rate
8. Screw the spring adjustment ring nut until reaching the desired set point value
9. Close the bleed valve venting to the atmosphere
10. Check for lock up of the regulator
11. If lock up is achieved solely open the outlet valve of the station

8.2 START UP

1. Very slowly open the outlet on-off valve and if necessary, adjust spring adjustment nut, to ensure the correct outlet pressure if the regulator.
2. Tighten the spring cap

9.0 REQUIRED TOOLS

Type	Tool	Description sizes in mm	
A		Combination wrench	Ch. 8-9-10-11-12-13- 14-15-16-17-18-19-20- 21-22-23-24-25-26-27- 41
B		Adjustable wrench	L. 30
C		Socket wrench	Ch. 8-9-10-11-12-13- 14-15-16-17-18-19-20- 24-26-27-36-46
D		Allen wrench	Ch. 3-4-5-6-7-8-19
E		Philips screwdriver	Es.Ch PH 0 x 100 - PH 1x125 – PH 2x150
F		Flat head screwdriver	0.5 x 3 x 75 1.2 x 6.5 x125
G		Snap ring pliers	Cod.10÷25 19÷60

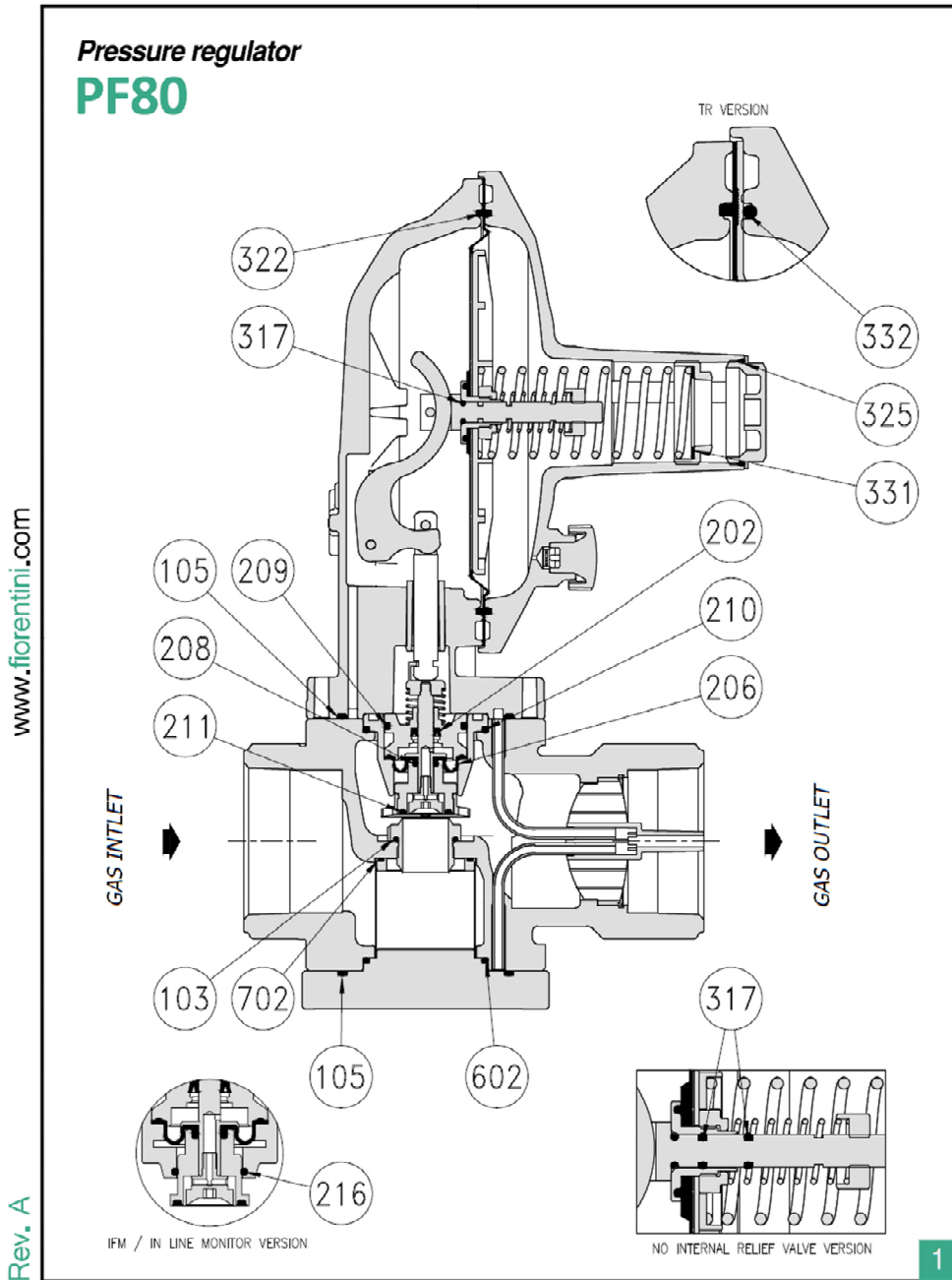



www.fiorentini.com

Rev. A

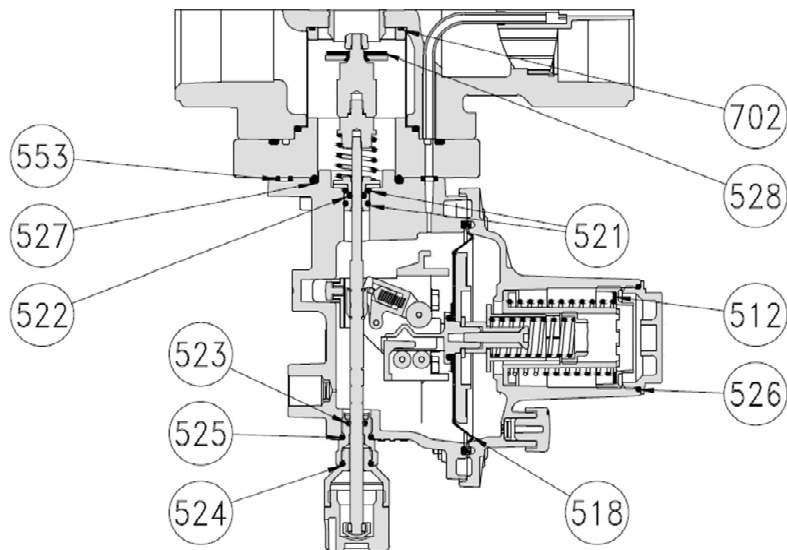

WHIT INTEGRATED SLAM-SHUT VALVE VERSION

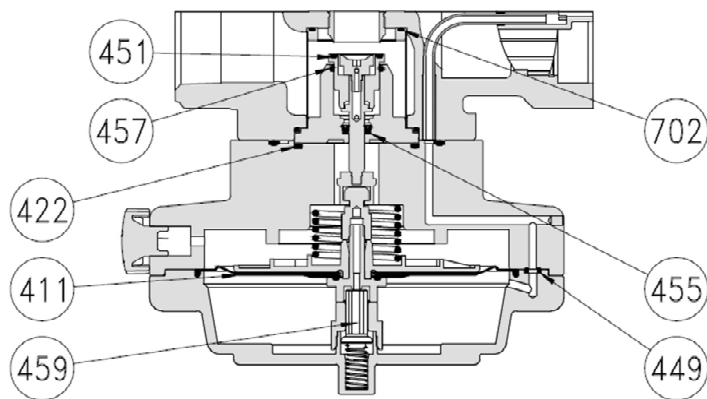

WHIT INTEGRATED INDEPENDENT MONITOR DEVICE VERSION

Pressure regulator
PF120

www.fiorentini.com

Rev. A

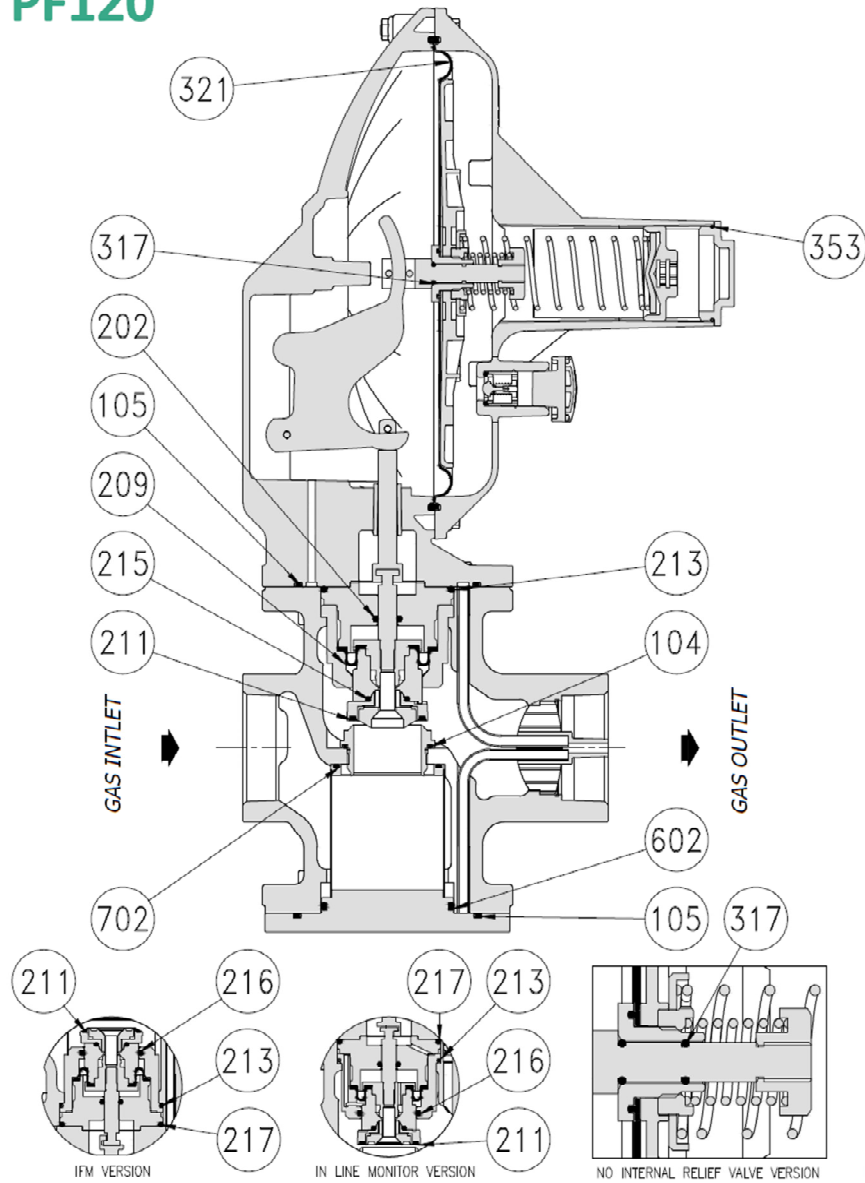

1



www.fiorentini.com

Rev. A

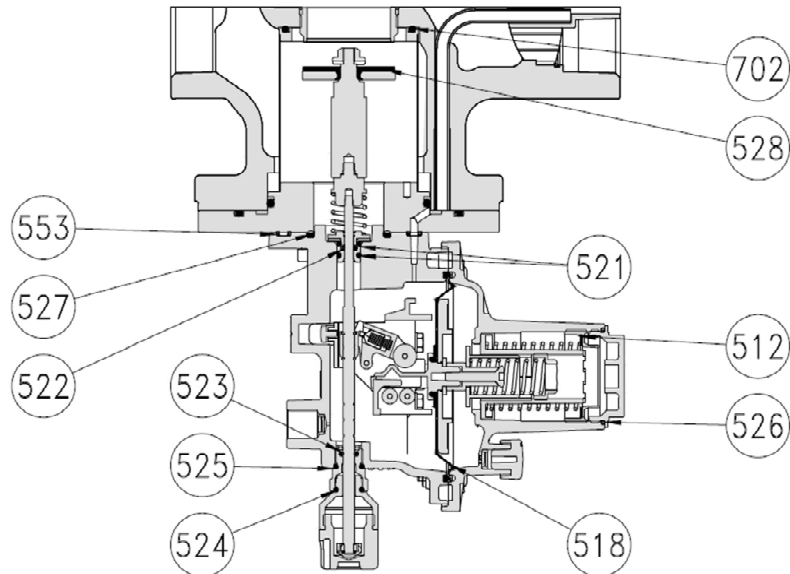

WHIT INTEGRATED SLAM-SHUT VALVE VERSION

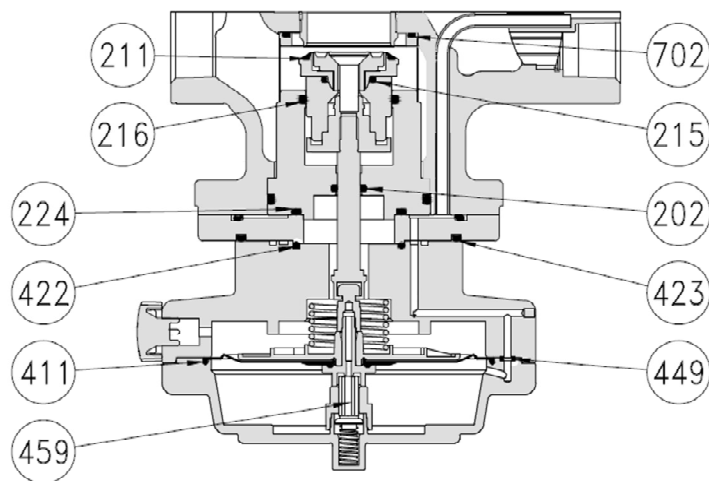

WHIT INTEGRATED INDEPENDENT MONITOR DEVICE VERSION