

72S

COFANO MOTORE

ENGINE COVER
CAPO MOTOR

COFFRE MOTEUR
MOTORHAUBE

DALLA MACCHINA
DE LA MAQUINA
DE LA MACHINE
FROM THE MACHINE
AB DER MASCHINE

★N.

737724

01

Rev.
2

01/2005

ZENNE

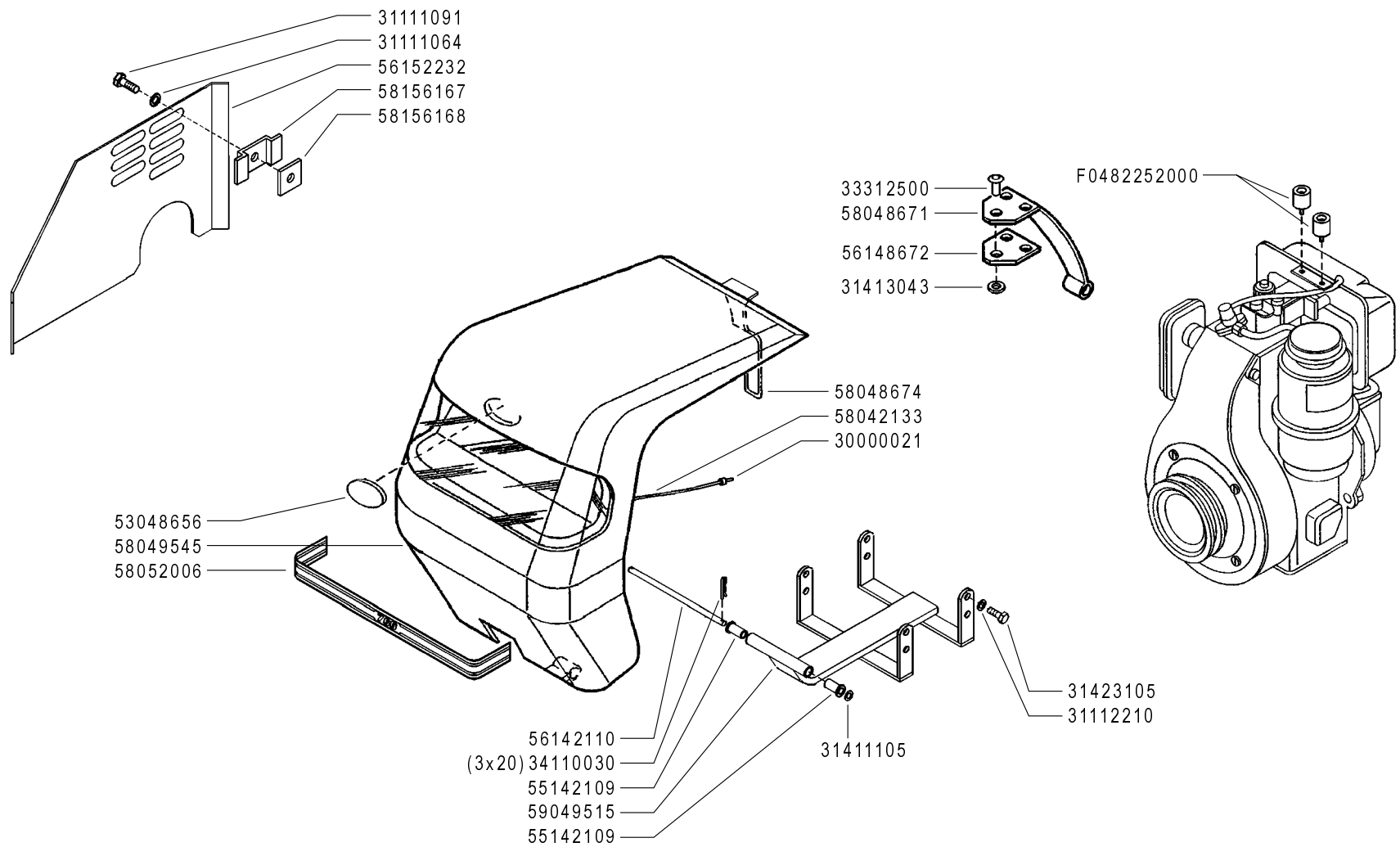

72S

COFANO MOTORE (760)

ENGINE COVER
 CAPO MOTOR

COFFRE MOTEUR
 MOTORHAUBE

DALLA MACCHINA
 DE LA MAQUINA
 DE LA MACHINE
 FROM THE MACHINE
 AB DER MASCHINE

N.

01 A 0

Rev.

01/2005

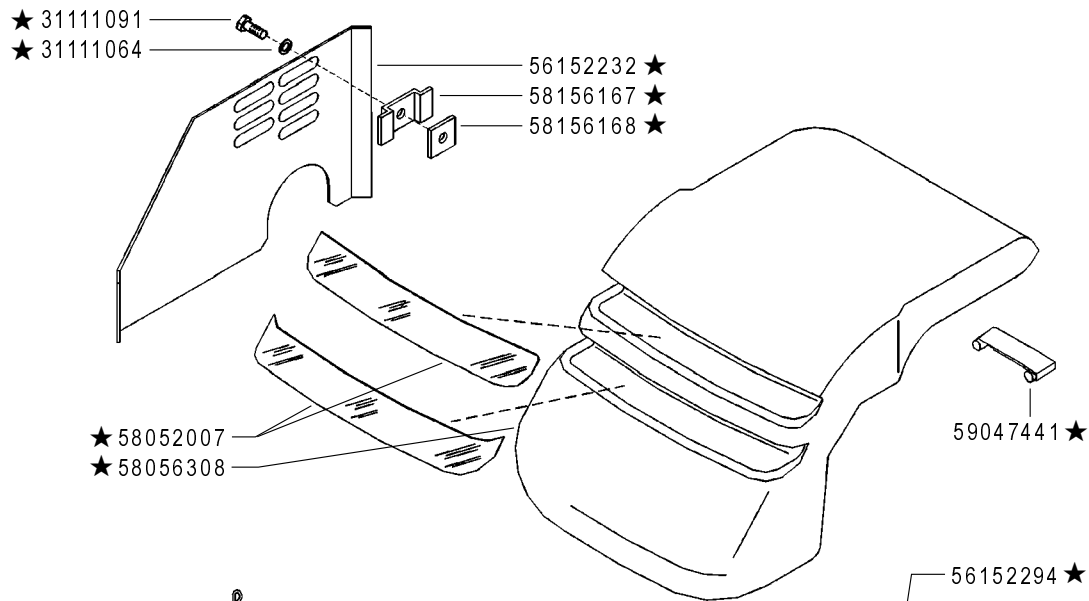

760

58057672 ★



53048656

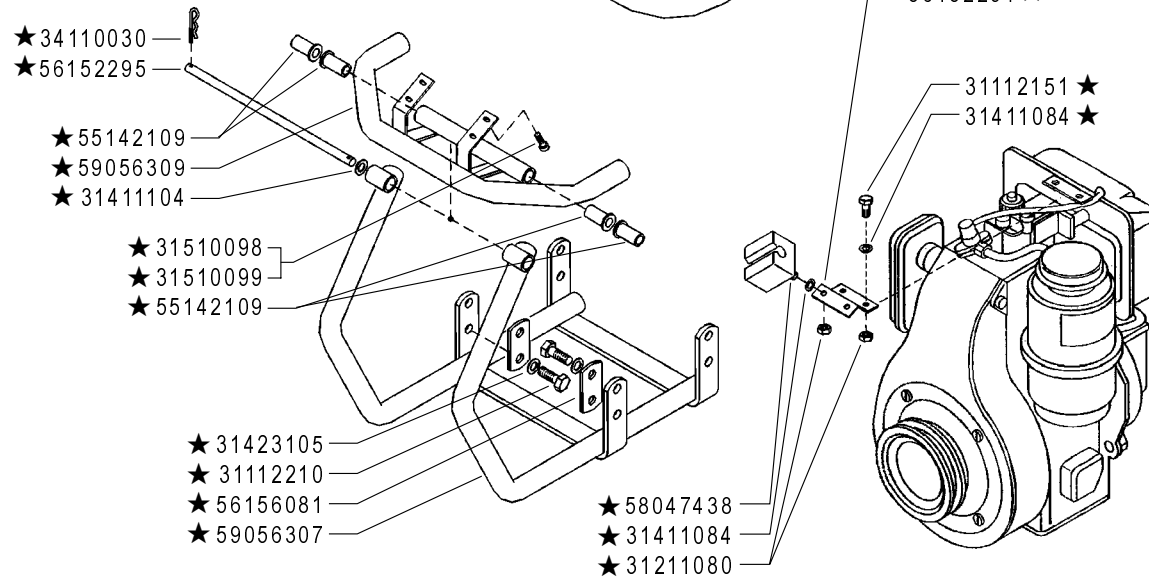

72S

COFANO MOTORE (760)

ENGINE COVER
CAPO MOTOR

COFFRE MOTEUR
MOTORHAUBE

DALLA MACCHINA
DE LA MAQUINA
DE LA MACHINE
FROM THE MACHINE
AB DER MASCHINE

★ N.

01 A 1

Rev.

01/2007

782403

ZENNE

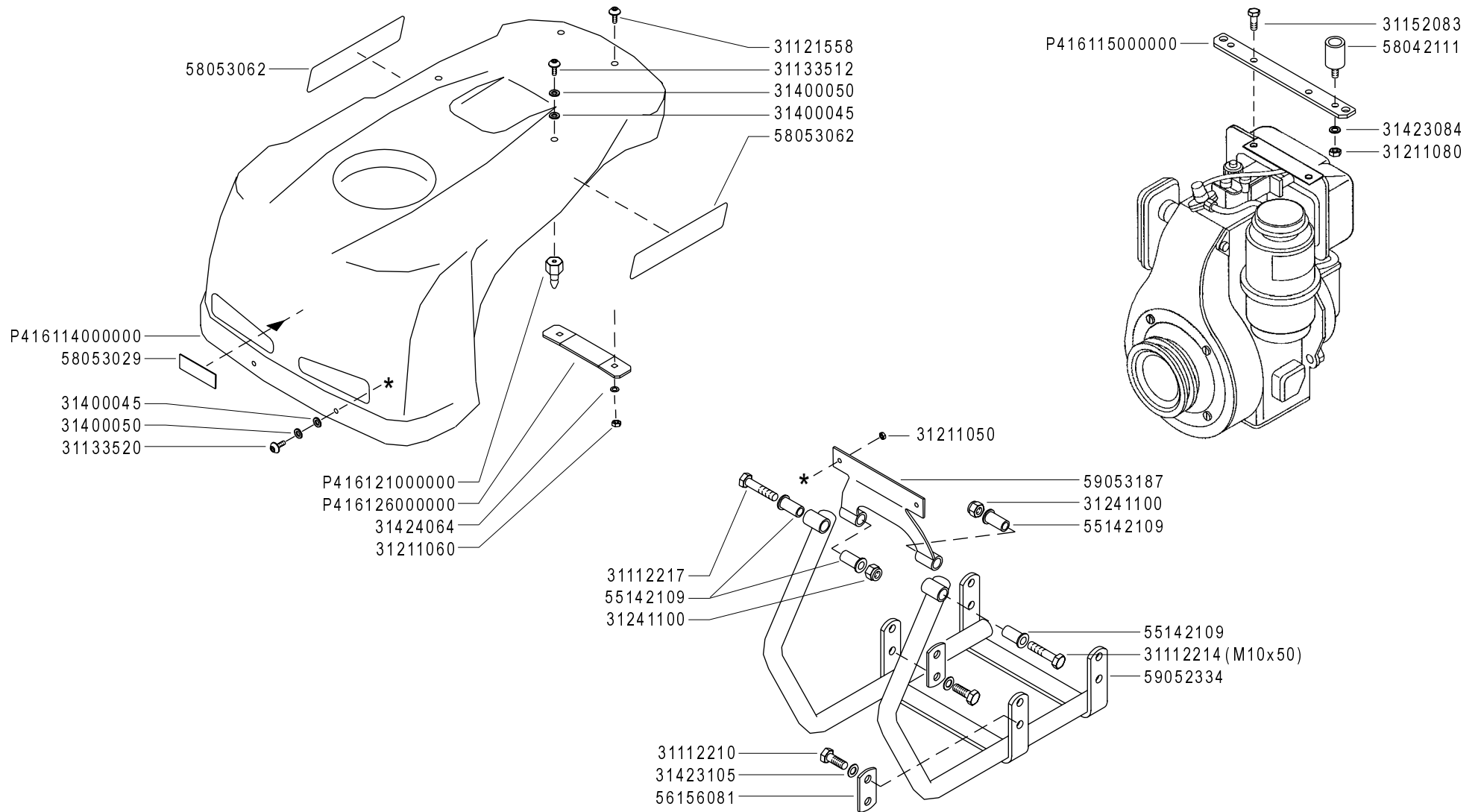

72S

COFANO MOTORE (XB 60)

ENGINE COVER
CAPO MOTOR

COFFRE MOTEUR
MOTORHAUBE

DALLA MACCHINA
DE LA MAQUINA
DE LA MACHINE
FROM THE MACHINE
AB DER MASCHINE

N.

01 B 0

01/2005

Rev.

ZENNE

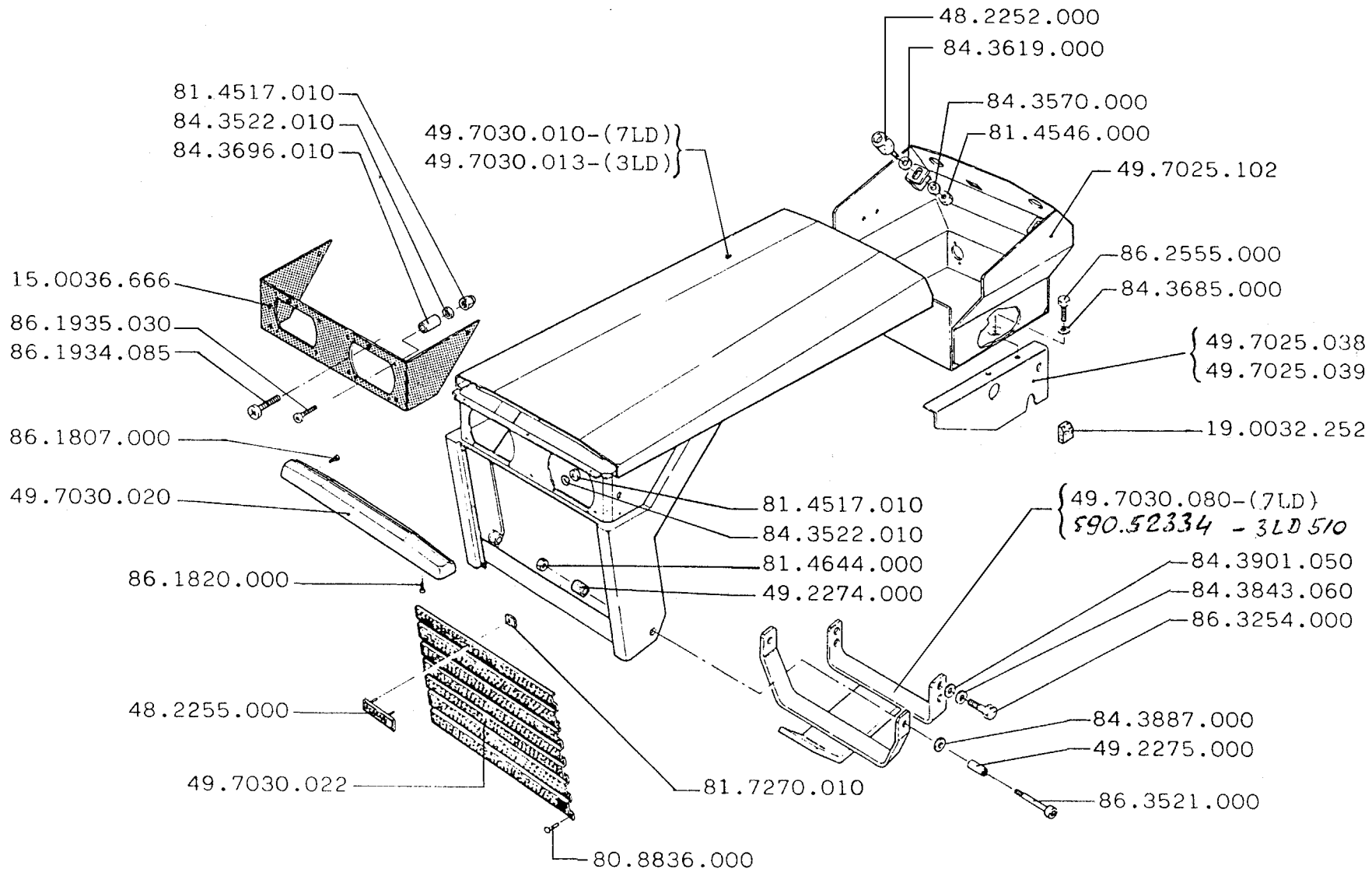

72S

COFANO MOTORE CON AVVIAM. ELETTRICO

ENGINE COVER
WITH ELECTRIC STARTER
CAPO MOTOR
CON ARRANQUE ELECTRICO

COFFRE MOTEUR
AVEC DÉMARRAGE ÉLECTRIQUE
MOTORHAUBE
MIT ELEKTROSTART

DALLA MACCHINA
DE LA MAQUINA
DE LA MACHINE
FROM THE MACHINE
AB DER MASCHINE

N.

Rev.

02 **0**

09/1991

ZENNE

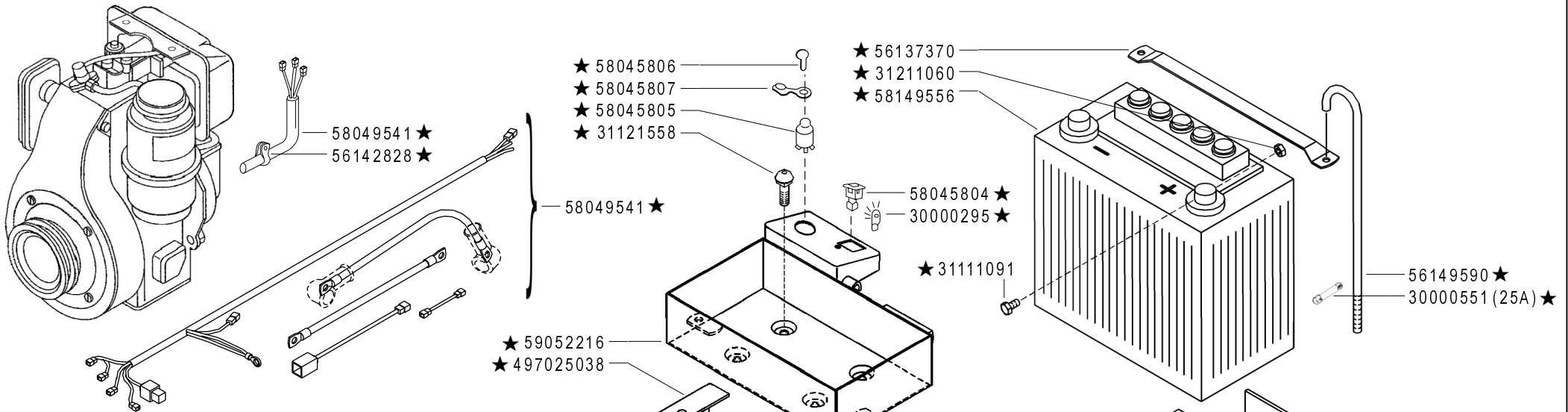

AVVIAMENTO SENZA FANALI - ELECTRIC STARTER WITHOUT LIGHTS
 DÉMARRAGE ELECTRIQUE SANS FEUX - ARRANQUE SIN FANALES
 ELEKTROSTARTER OHNE LICHTER

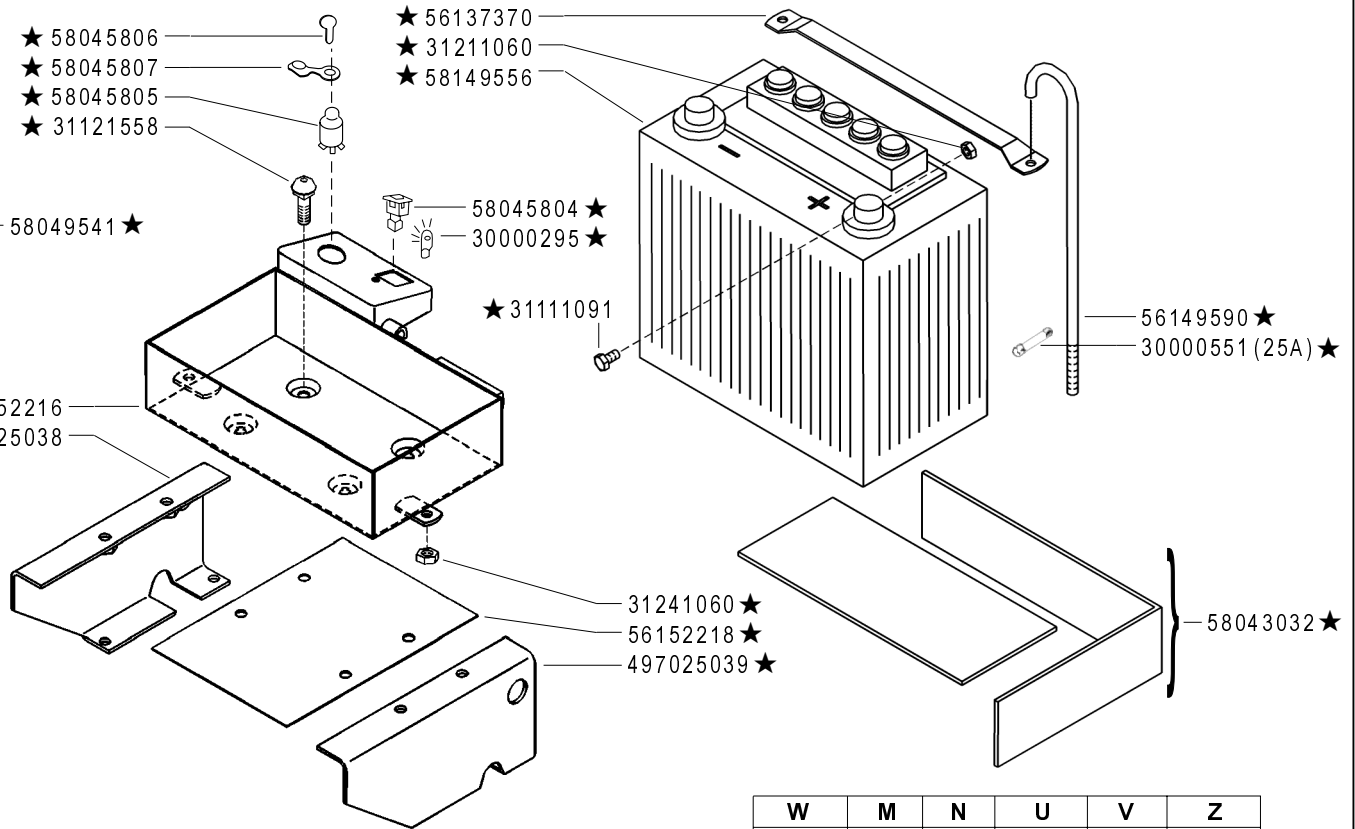
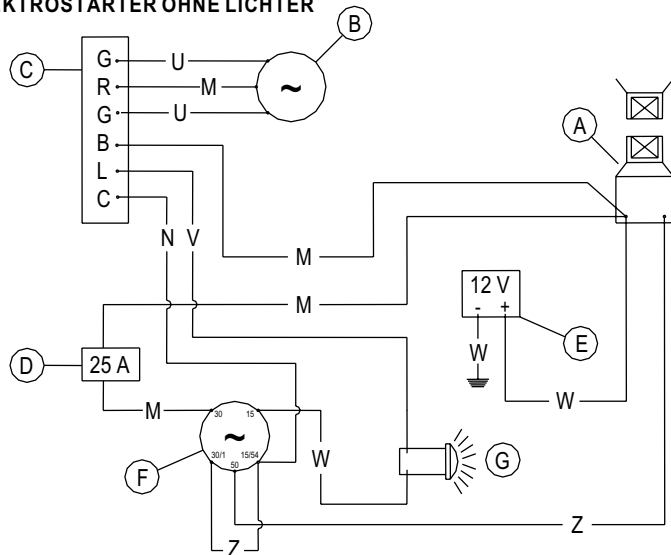

W	M	N	U	V	Z
NERO	ROSSO	VERDE	GIALLO	BIANCO	MARRONE
BLACK	RED	GREEN	YELLOW	WHITE	BROWN
NOIR	ROUGE	VERT	JAUNE	BLANC	MARRON
NEGRO	ROJO	VERDE	AMARILLO	BLANCO	CASTANO
SCHWARZ	ROT	GRÜN	GLEB	WEISS	BRAUN

A	B	C	D	E (12V 33A) 232x130xh167	F	G
MOT. D'AVVIAMENTO STARTER DÉMARREUR MOT. DE ARRANQUE ANLASSMOTOR	GENERATORE GENERATOR GÉNÉRATEUR GENERADOR GENERATOR	REGOLATORE REGULATOR RÉGULATEUR REGULADOR REGLER	FUSIBILI FUSES FUSIBLES FUSIBLES SCHMELZSICHERUNGEN	BATTERIA BATTERY BATTERIE BATERIA BATTERIE	INTERRUTTORE SWITCH INTERRUPTEUR INTERRUPTOR SCHALTER	SPIA CARICA BATTERIA BATTERY LONG WARN. LIGHT TEMOIN CHARG. BATTERIE LUZ CARGA BATERIA BATTERIELADUNG KTRL. LAMPE

72S

AVVIAMENTO ELETTRICO

ELECTRIC STARTER
 ARRANQUE ELECTRICO

DÉMARRAGE ELECTRIQUE
 ELEKTROSTART

DALLA MACCHINA
 DE LA MAQUINA
 DE LA MACHINE
 FROM THE MACHINE
 AB DER MASCHINE

★N.

737724

03

Rev.
1

01/2005

ZENNE

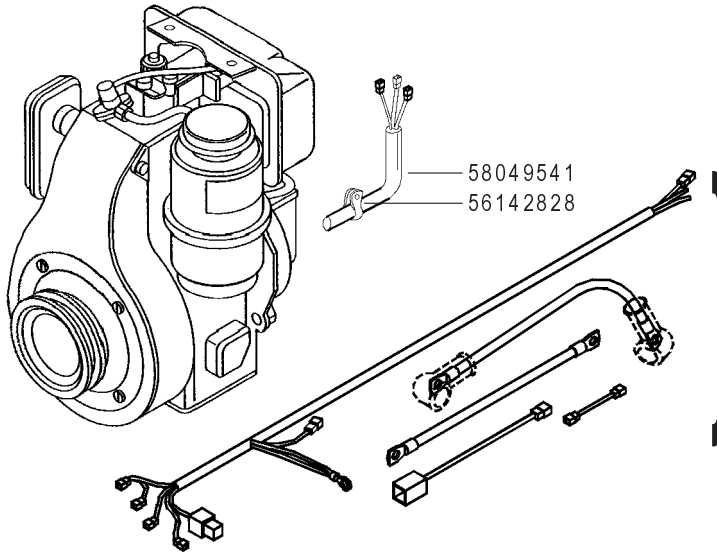

- (1) ★ F0825500220
- ★ F0825500210
- 58045807
- (2) ★ F0825500200
- 31121558

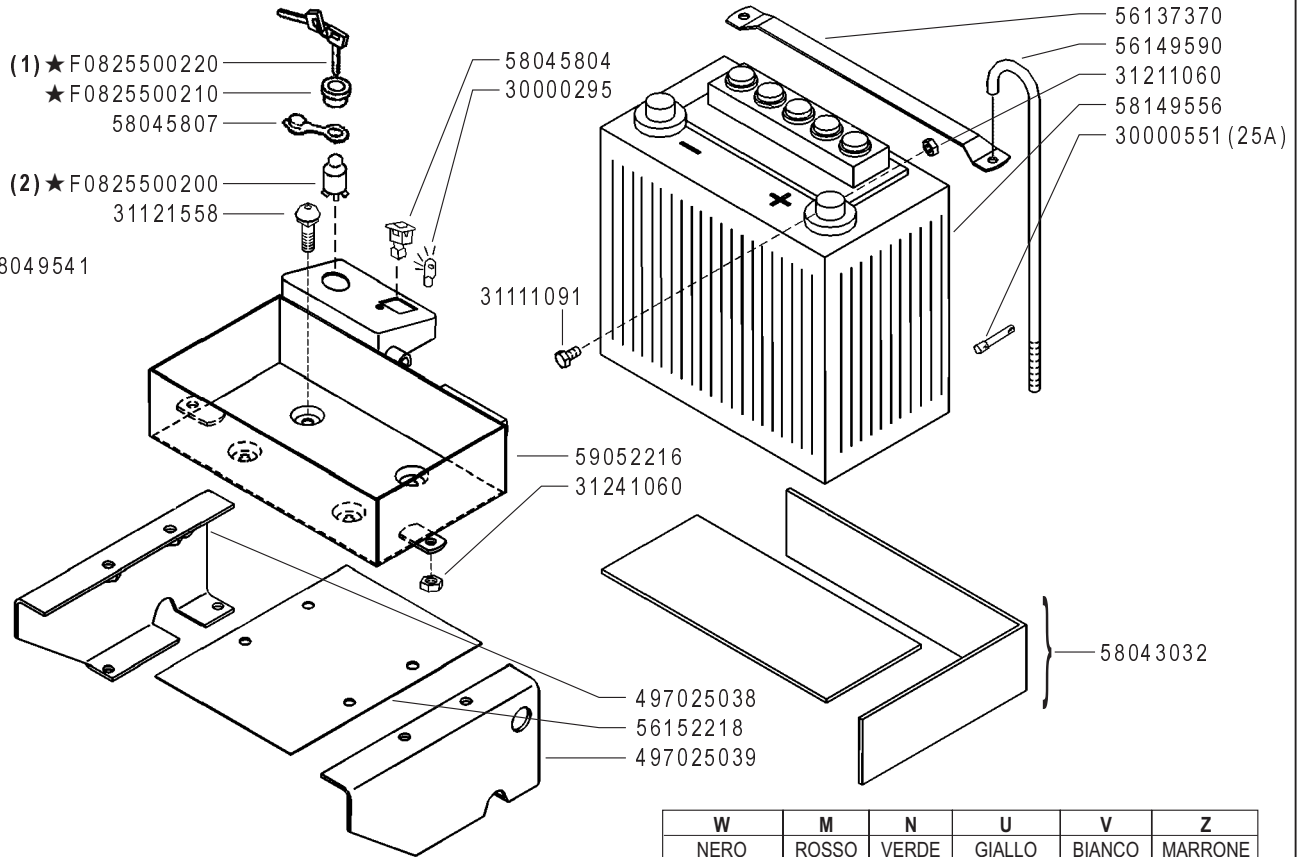

AVVIAMENTO SENZA FANALI - ELECTRIC STARTER WITHOUT LIGHTS
 DÉMARRAGE ÉLECTRIQUE SANS FEUX - ARRANQUE SIN FANALES
 ELEKTROSTARTER OHNE LICHTER

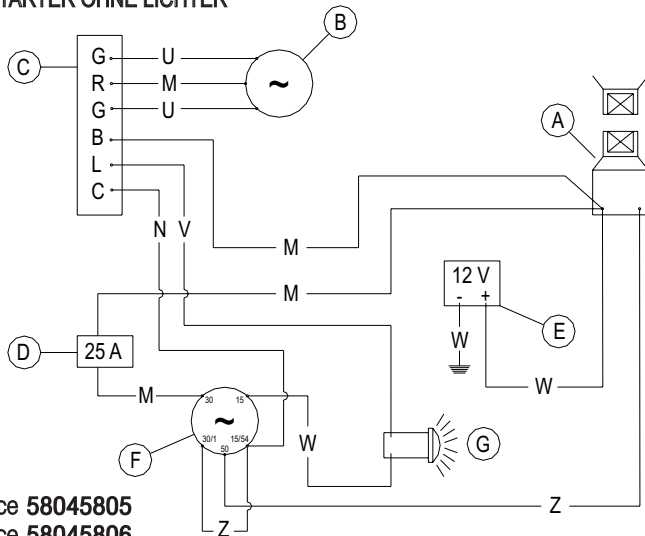

(2) sostituisce 58045805
 (1) sostituisce 58045806

W	M	N	U	V	Z
NERO	ROSSO	VERDE	GIALLO	BIANCO	MARRONE
BLACK	RED	GREEN	YELLOW	WHITE	BROWN
NOIR	ROUGE	VERT	JAUNE	BLANC	MARRON
NEGRO	ROJO	VERDE	AMARILLO	BLANCO	CASTANO
SCHWARTZ	ROT	GRÜN	GLEB	WEISS	BRAUN

A	B	C	D	E (12V 33A) 232 x 130 x 1167	F	G
MOT. D'AVVIAMENTO STARTER	GENERATORE GENERATOR	REGOLATORE REGULATOR	FUSIBILI FUSES	BATTERIA BATTERY	INTERRUTTORE SWITCH	SPIA CARICA BATTERIA BATTERY LONG WARN. LIGHT
DÉMARREUR	GÉNÉRATEUR GENERADOR	RÉGULATEUR REGULADOR	FUSIBLES FUSIBLES	BATTERIE BATERIA	INTERRUPTEUR INTERRUPTOR	TEMOIN CHARG. BATTERIE LUZ CARGA BATERIA
MOT. DE ARRANQUE ANLASSMOTOR	GENERATOR	REGLER	SCHMELZSICHERUNGEN	BATTERIE	SCHALTER	BATTERIELADUNG KTRTL. LAMPE

72S

AVVIAMENTO ELETTRICO

ELECTRIC STARTER
 ARRANQUE ELECTRICO

DÉMARRAGE ÉLECTRIQUE
 ELEKTROSTART

DALLA MACCHINA
 DE LA MAQUINA
 DE LA MACHINE
 FROM THE MACHINE
 AB DER MASCHINE

AGGIORNAMENTO
 REVISION
 MISE A JOUR
 APLAZAMIENTO I
 ANPASSUNG

★ N.

03

Rev.
2

01/2007

ZENNE

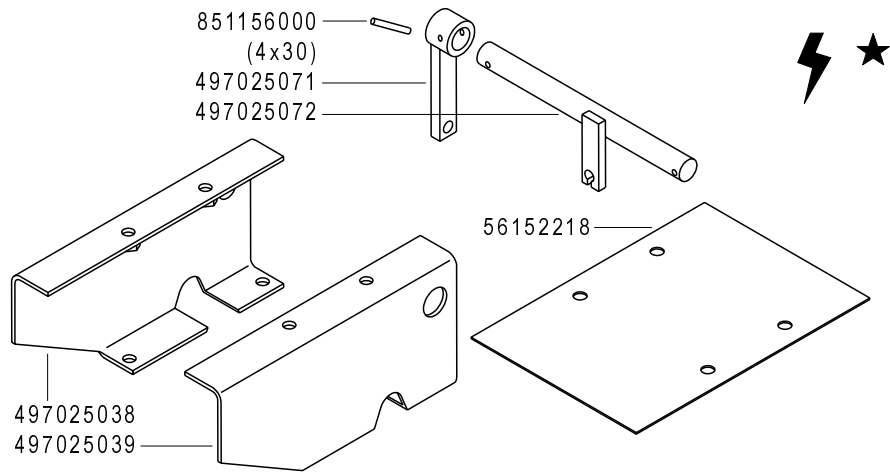

**AVVIAMENTO ELETTRICO - ELECTRIC START - DÉMARRAGE ELECTRIQUE
 ARRANQUE ELECTRICO - ELEKTROSTART**

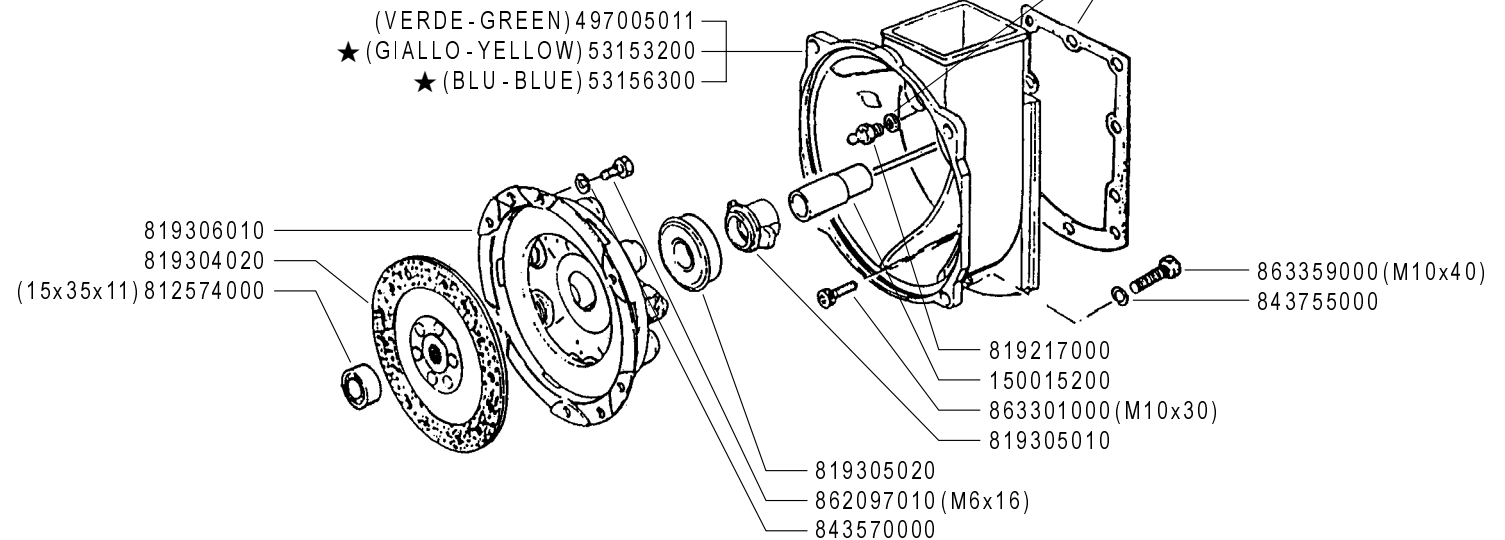
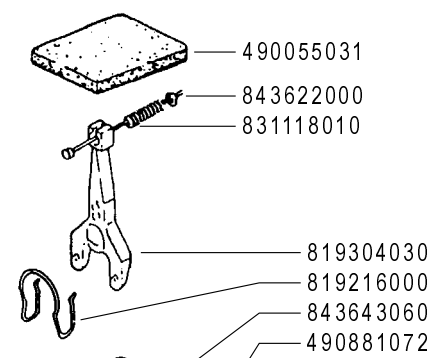

72S

FRIZIONE

CLUTCH
 EMBRAGUE

EMBRAYAGE
 KUPPLUNG

DALLA MACCHINA
 DE LA MAQUINA
 DE LA MACHINE
 FROM THE MACHINE
 AB DER MASCHINE

★N.

737724

04

Rev.
2

01/2005

ZENNE

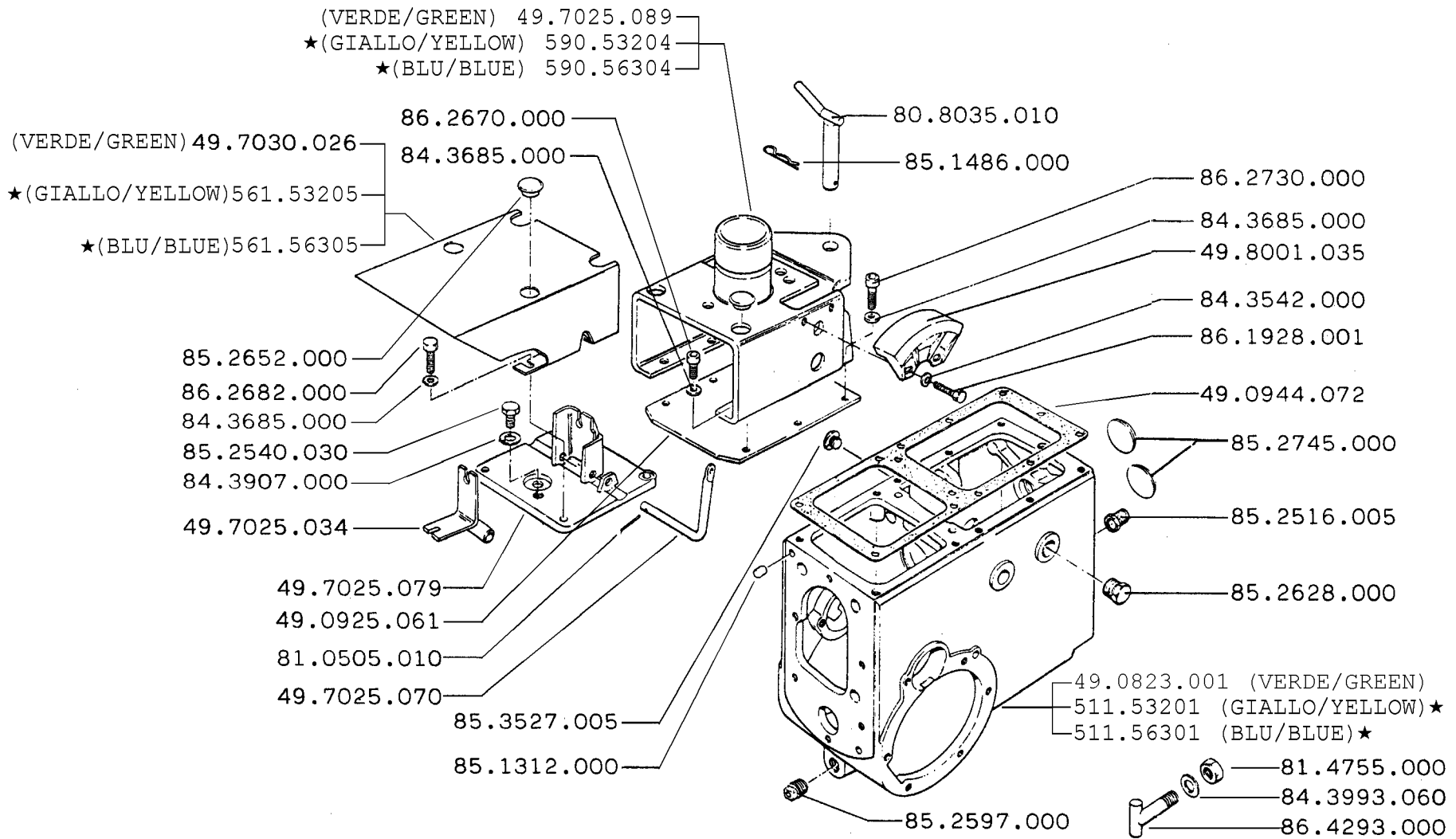

72S

SCATOLA CAMBIO

GEARBOX
CAJA DE CAMBIO

BOITE DE VITESSES
WECHSELGETRIEBE

DALLA MACCHINA
DE LA MAQUINA
DE LA MACHINE
FROM THE MACHINE
AB DER MASCHINE

AGGIORNAMENTO

APLAZAMIENTO

MISE A JOUR

REVISION

ANPASSUNG

★N.

05

Rev.

1

01/2005

ZENNE

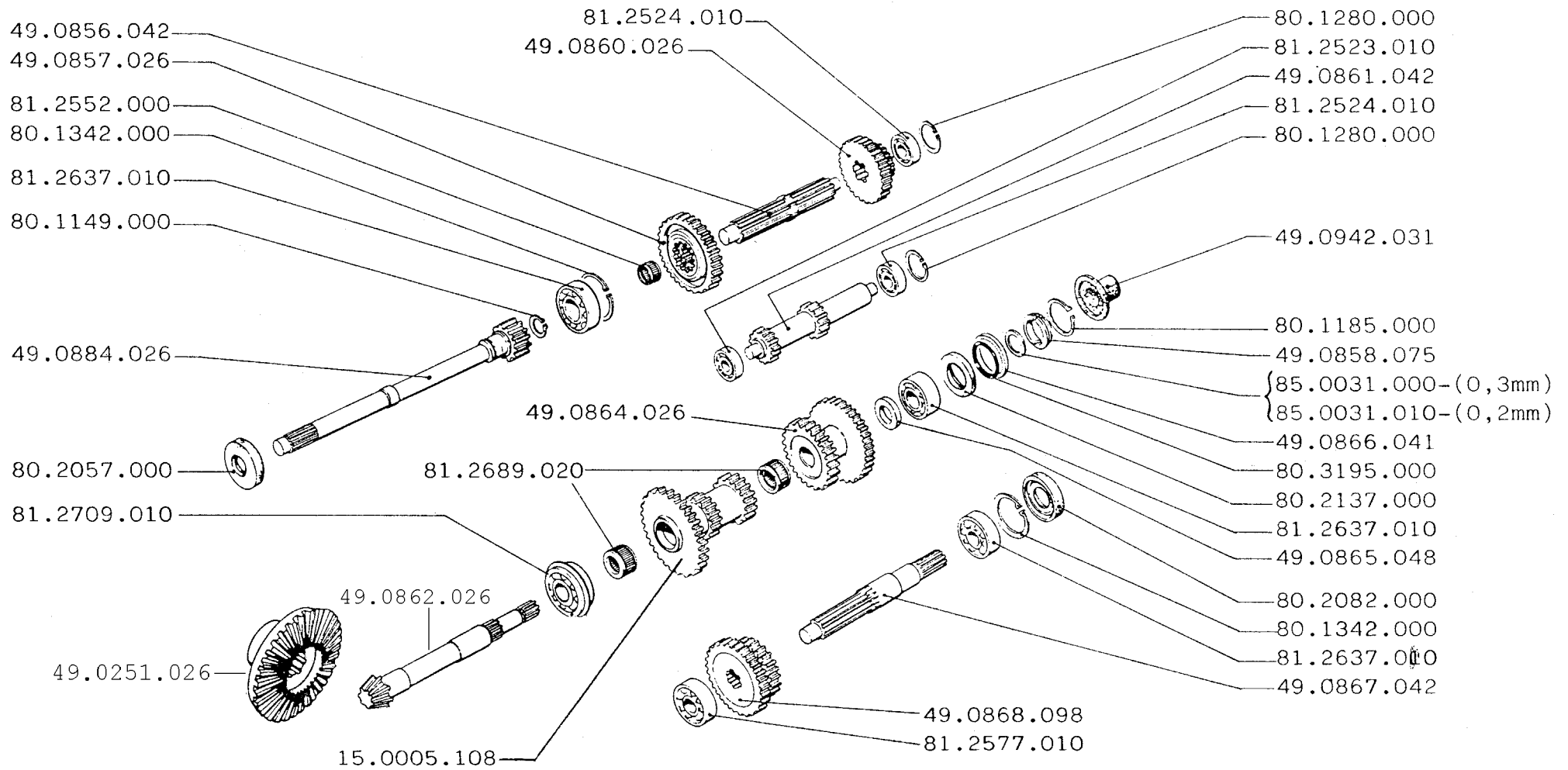

72S

INGRANAGGI

GEARS
ENGRANAJES

ENGRANAGES
ZÄHRÄDER

DALLA MACCHINA
DE LA MAQUINA
DE LA MACHINE
FROM THE MACHINE
AB DER MASCHINE

N.

06

Rev.
0

09/1991

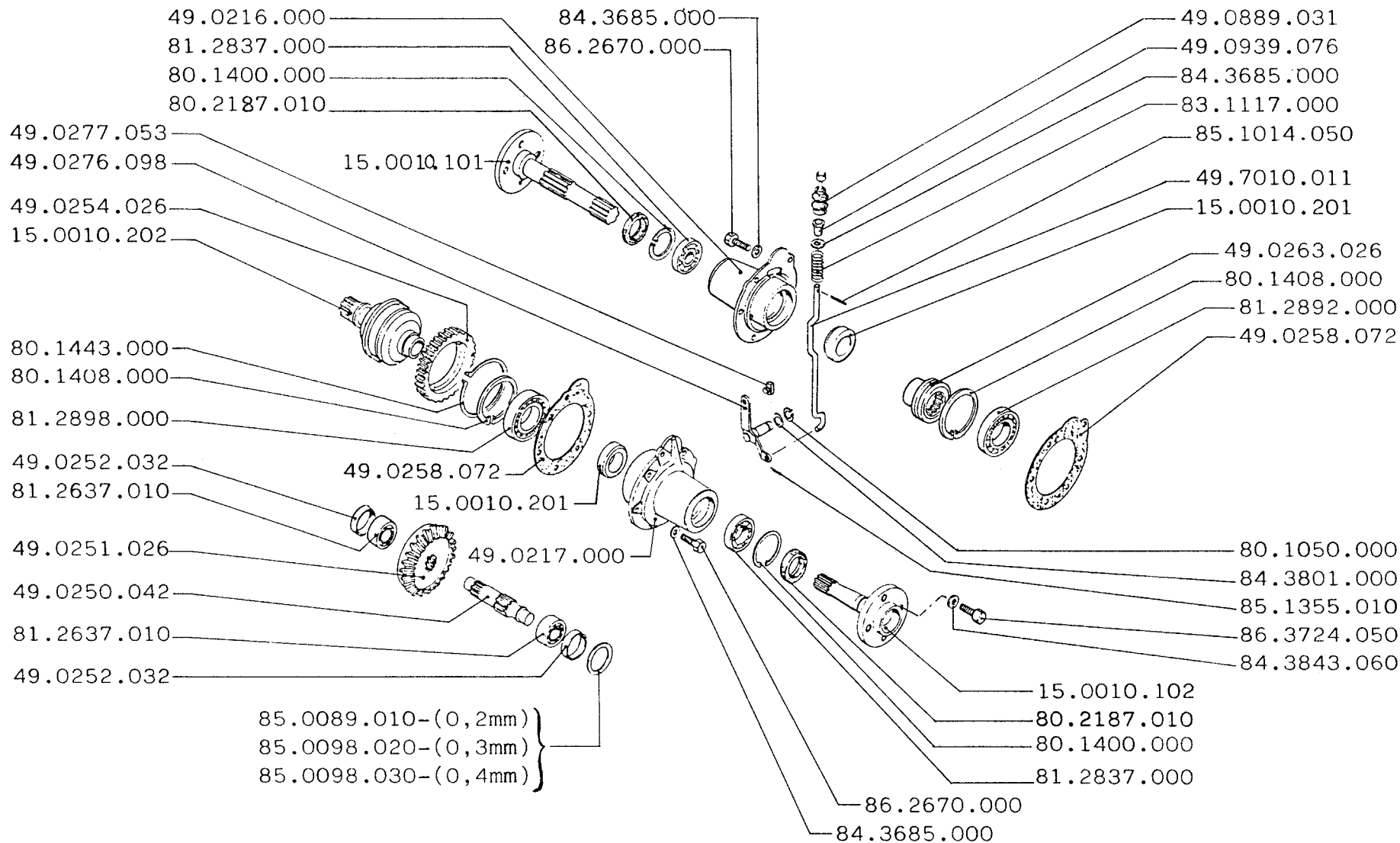

72S

DIFFERENZIALE (FRENI A TAMBURO)

DIFFERENTIAL (BRAKES DRUM)

DIFFERENCIAL (FRENOS A TAMBOR)

DIFFÉRENTIEL (FREINS A TAMBOUR)

DIFFERENTIAL (BREMSENTROMMEL)

DALLA MACCHINA
DE LA MAQUINA
DE LA MACHINE
FROM THE MACHINE
AB DER MASCHINE

N.

07

Rev.

0

09/1991

ZENNE

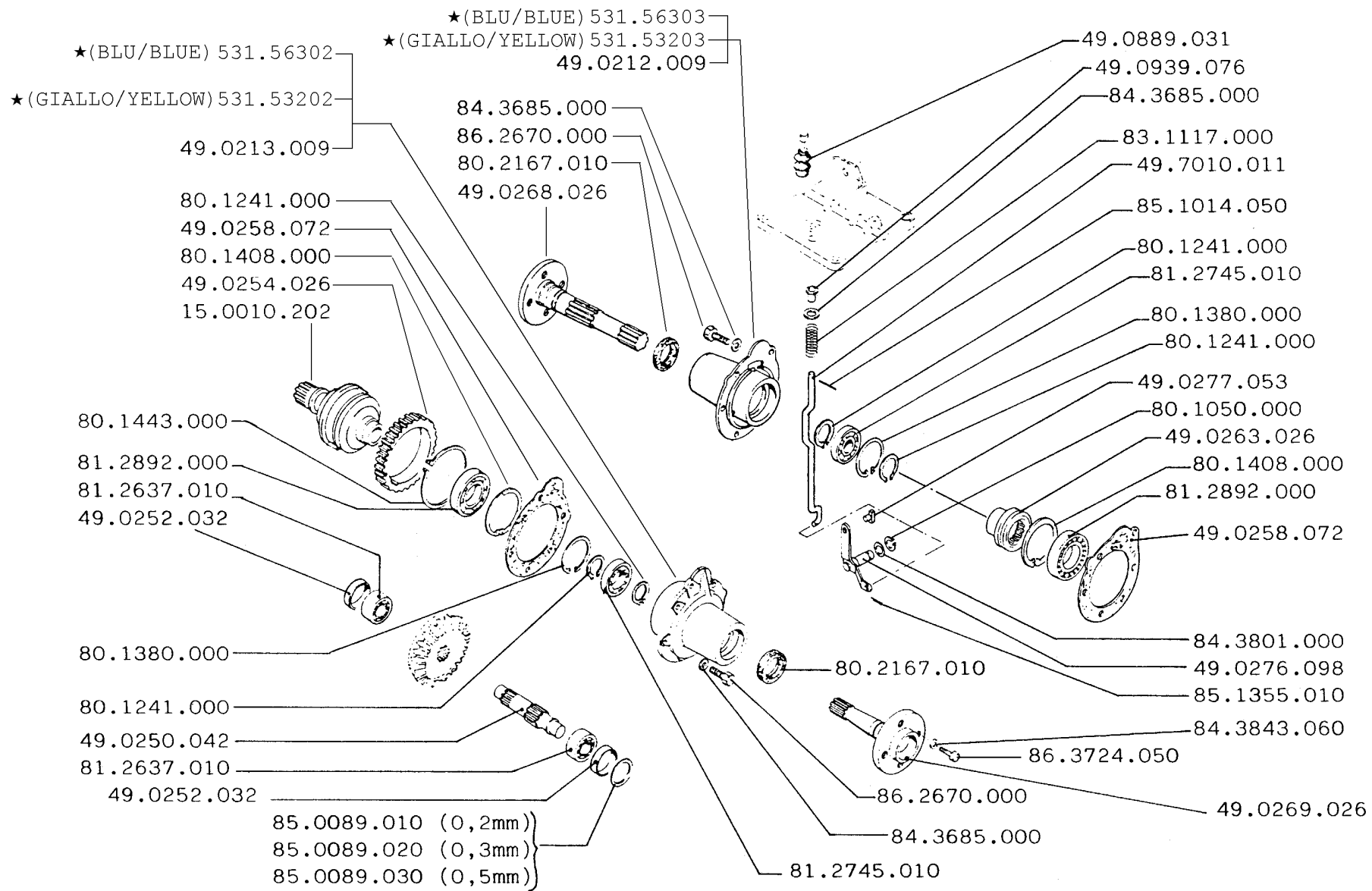

72S

DIFFERENZIALE (FRENI A NASTRO)

DIFFERENTIAL (TWO LEADING SHOE BRAKE)
DIFFERENCIAL (FRENOS DE CINTA)

DIFFERENTIEL (FREINS RUBAN)
DIFFERENTIAL (BANDBREMSEN)

DALLA MACCHINA
DE LA MAQUINA
DE LA MACHINE
FROM THE MACHINE
AB DER MASCHINE

AGGIORNAMENTO
APLAZAMIENTO
MISE A JOUR
REVISION
ANPASSUNG

★N.

08

Rev.
1

01/2005

ZENNE

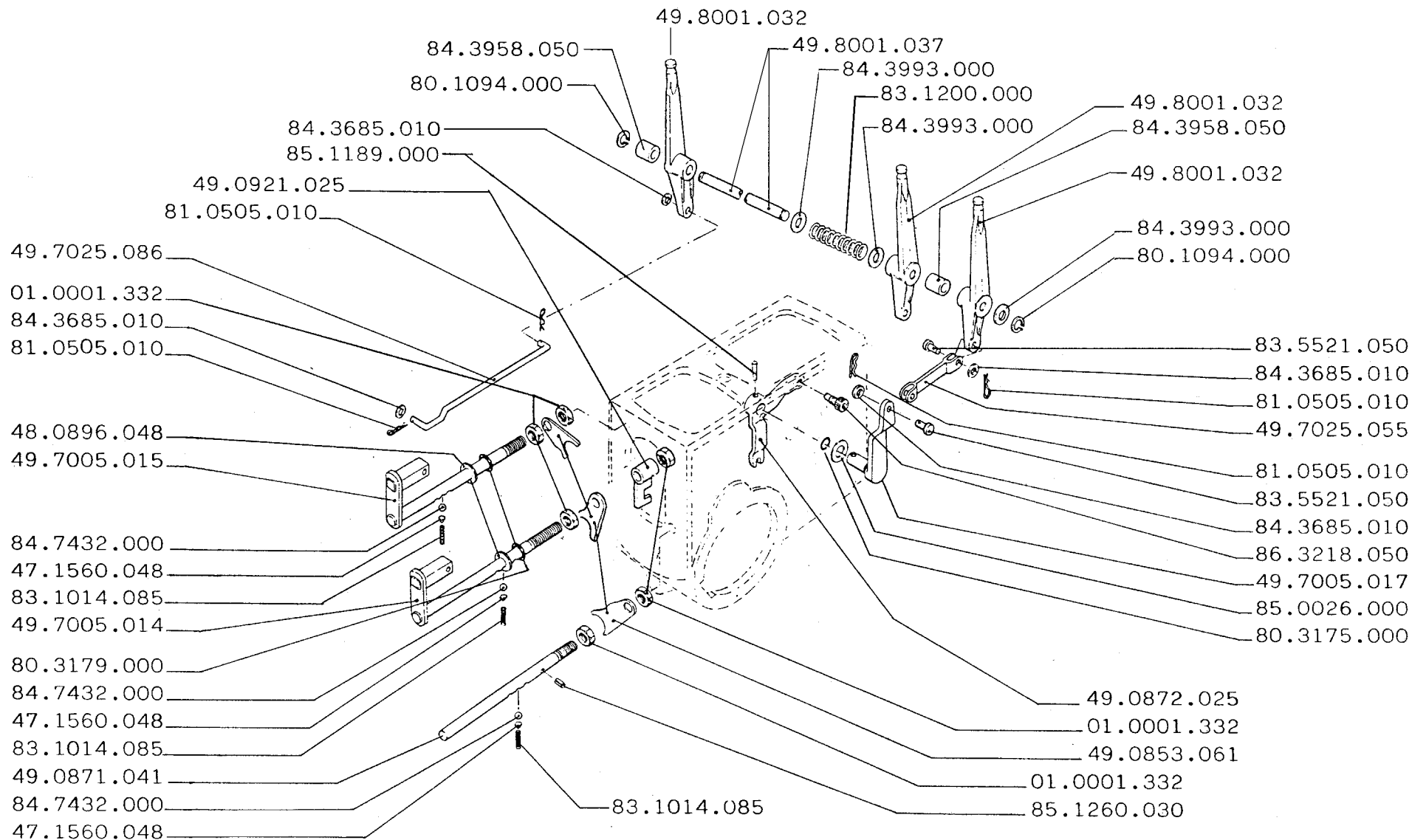

72S

COMANDI

CONTROLS
MANDOS

COMMANDES
ANTRIEBE

DALLA MACCHINA
DE LA MAQUINA
DE LA MACHINE
FROM THE MACHINE
AB DER MASCHINE

N.

09

Rev.

0

09/1991

ZENNE

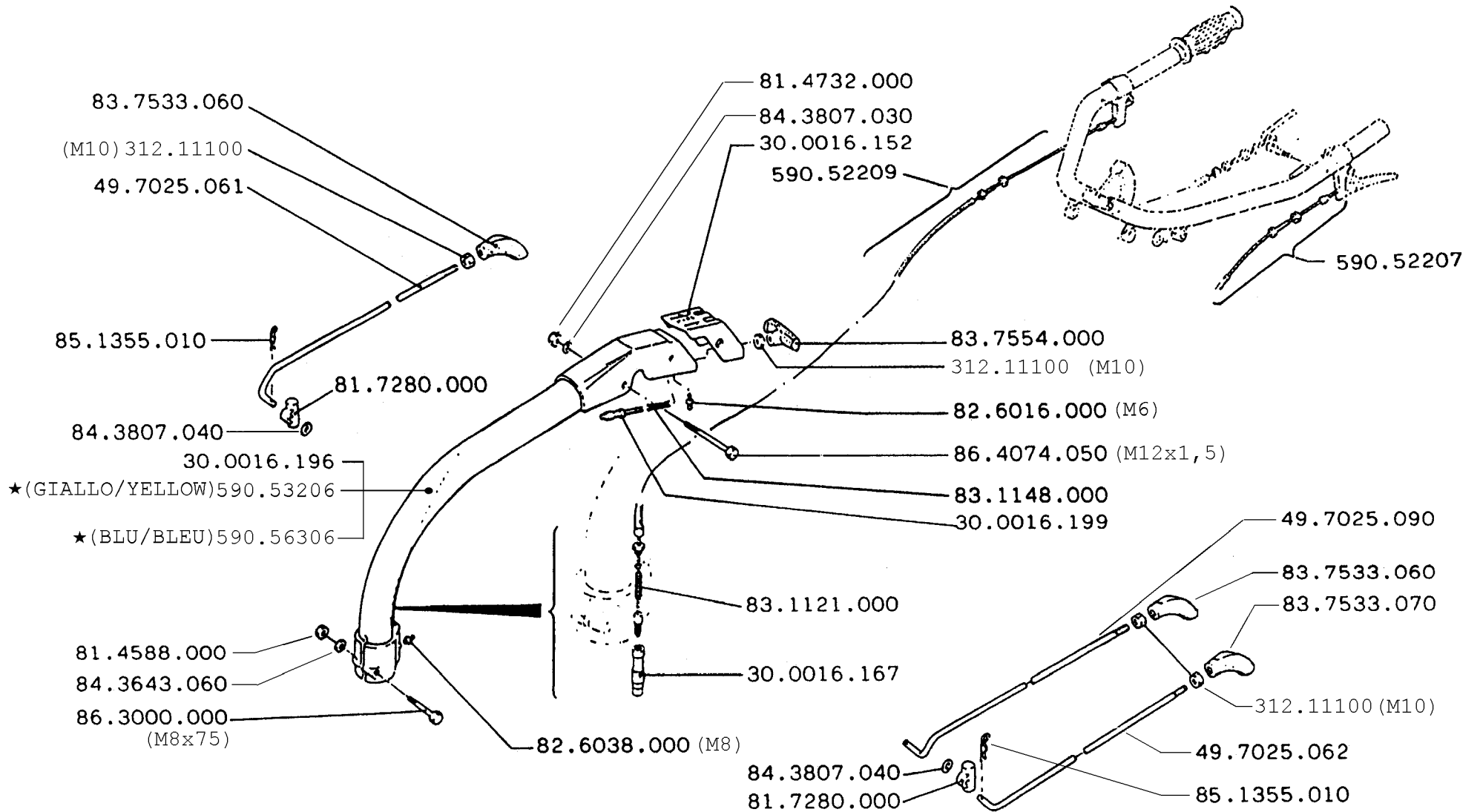

72S

STEGOLA

STEERING COLUMN
 COLUMNNA

PLANTON
 LENKSAULE

DALLA MACCHINA
 DE LA MAQUINA
 DE LA MACHINE
 FROM THE MACHINE
 AB DER MASCHINE

AGGIORNAMENTO

APLAZAMIENTO

MISE A JOUR

REVISION

ANPASSUNG

★N.

10

Rev.
 2

01/2005

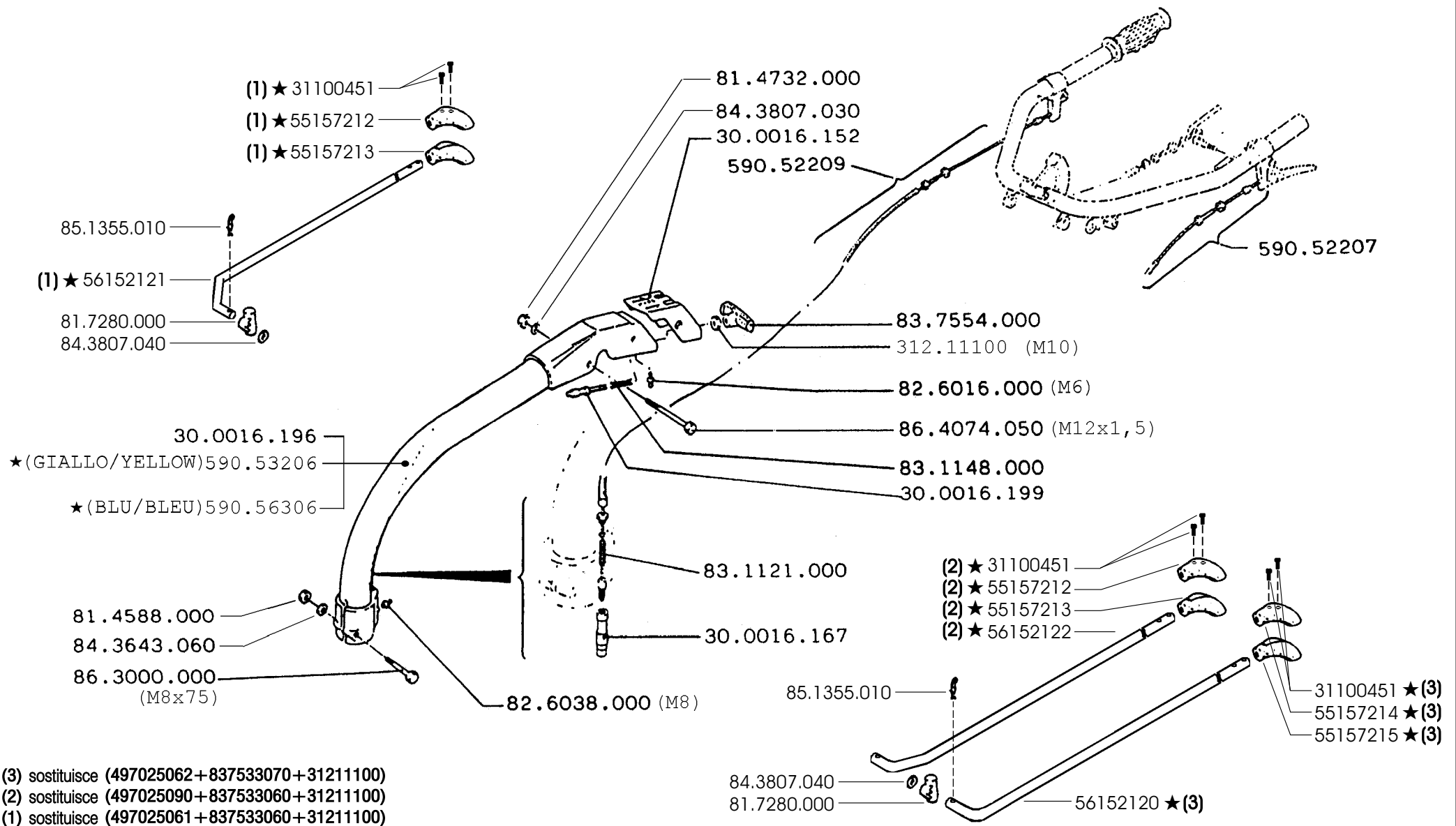

(3) sostituisce (497025062+837533070+31211100)
 (2) sostituisce (497025090+837533060+31211100)
 (1) sostituisce (497025061+837533060+31211100)

72S

STEGOLA

STEERING COLUMN
COLUMNNA

PLANTON
LENKSÄULE

DALLA MACCHINA
DE LA MAQUINA
DE LA MACHINE
FROM THE MACHINE
AB DER MASCHINE

AGGIORNAMENTO

APLAZAMIENTO

MISE A JOUR

REVISION

ANPASSUNG

★N.

10

Rev.
3

07/2006

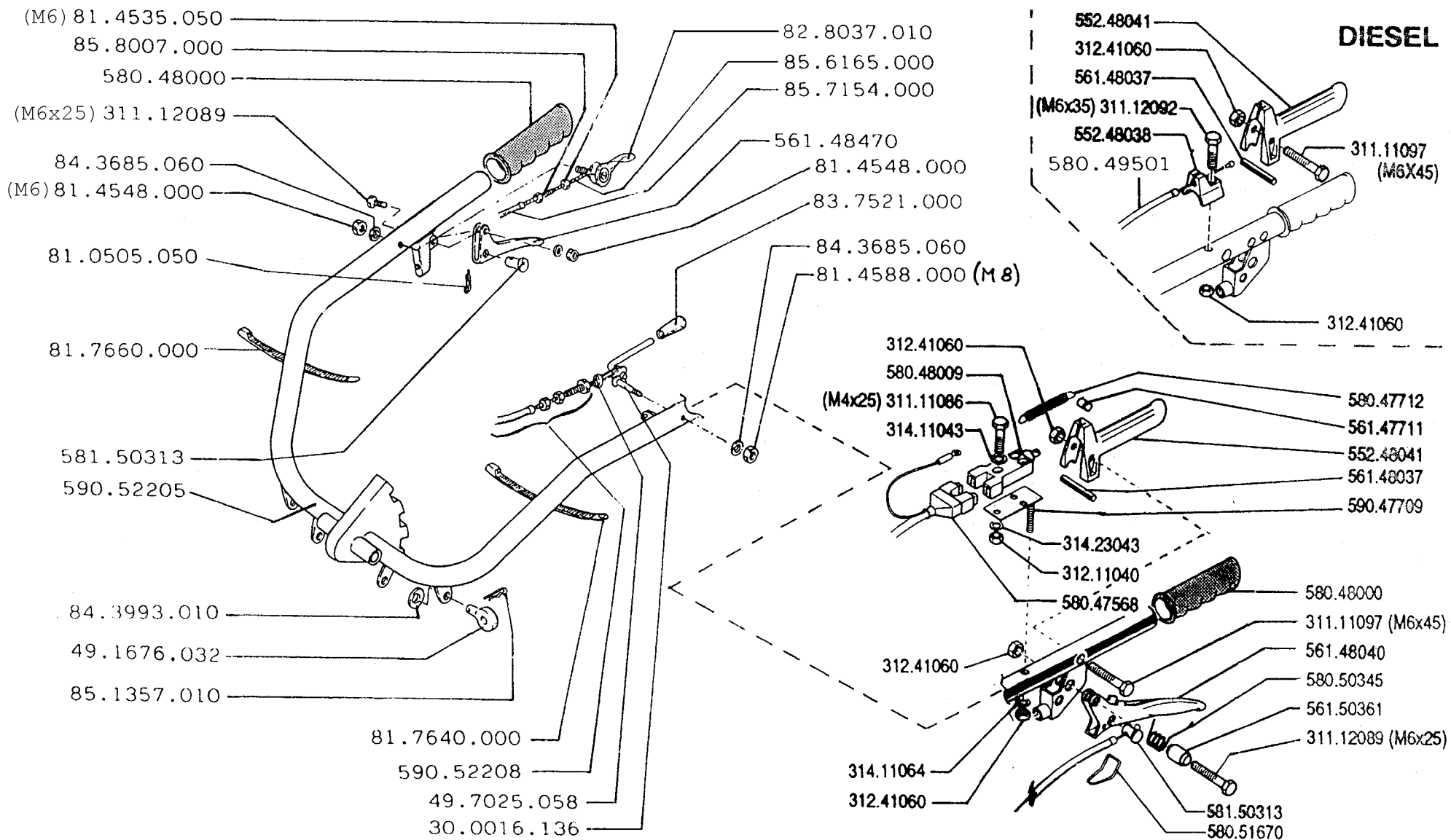

72S

MANUBRIO

HANDLEBAR
MANILLAR

MANCHERON
LENKER

DALLA MACCHINA
DE LA MAQUINA
DE LA MACHINE
FROM THE MACHINE
AB DER MASCHINE

N.

11

Rev.
1

08/1996

ZENNE

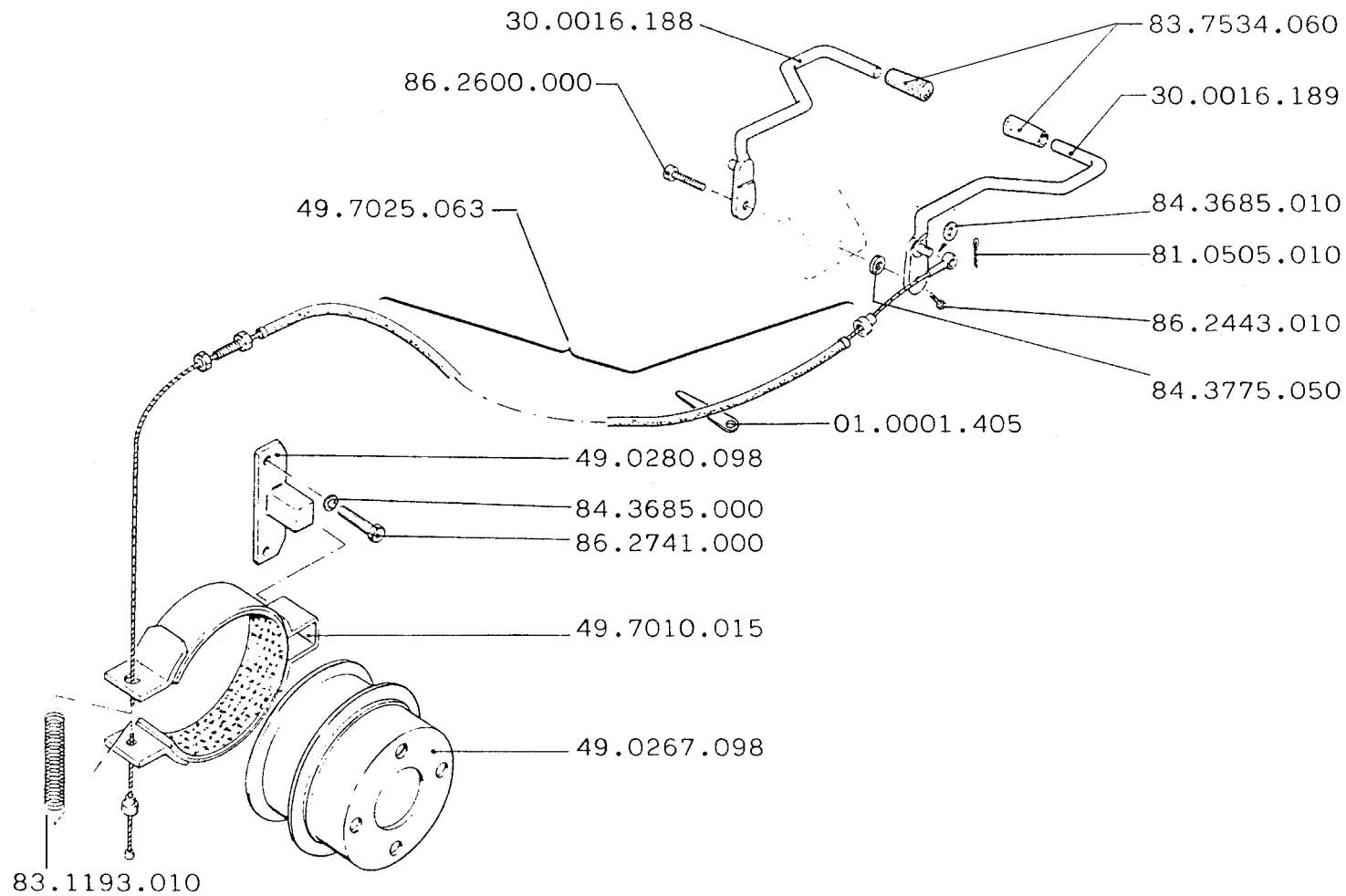

72S

FRENI A NASTRO

TWO LEADING SHOE BRAKE
FRENS DE CINTA

FREINS A RUBAN
BANDBREMSEN

DALLA MACCHINA
DE LA MAQUINA
DE LA MACHINE
FROM THE MACHINE
AB DER MASCHINE

N.

12

Rev.

0

09/1991

ZENNE

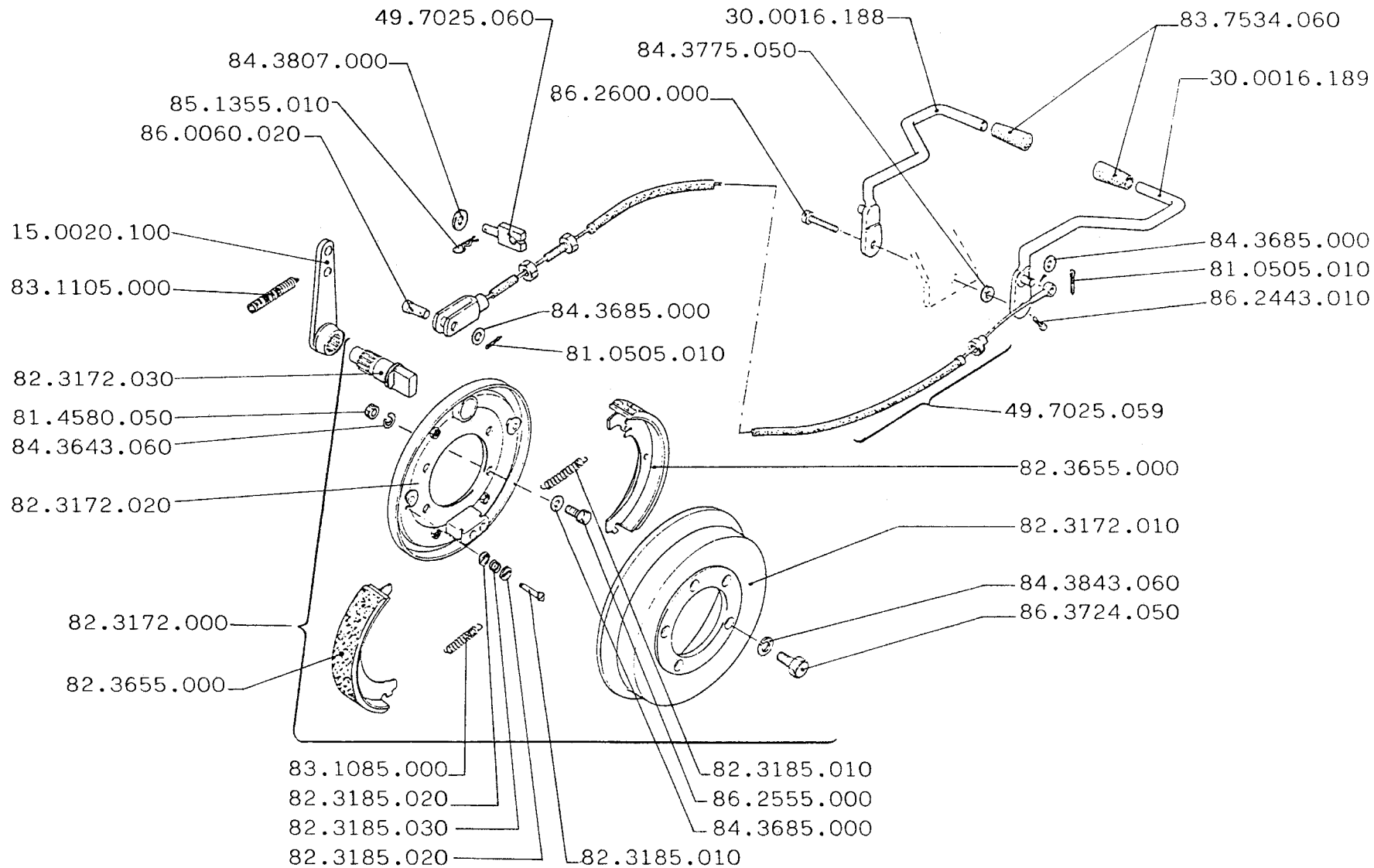

72S

FRENI A TAMBURO

DRUM BRAKE
FRENOS DE EXPANSION

FREINS A TAMBOUR
BRACKENBREMSEN

DALLA MACCHINA
DE LA MAQUINA
DE LA MACHINE
FROM THE MACHINE
AB DER MASCHINE

N.

13

Rev.
0

09/1991

ZENNE

5.00-12	84.8538.000	84.8832.000	84.9030.000	90.6016.000
6.5-80/12	84.8530.000	84.8835.000	84.9043.000	90.6016.000
6.5-80/15	84.8564.000	84.8847.000	84.9099.040	90.6016.000

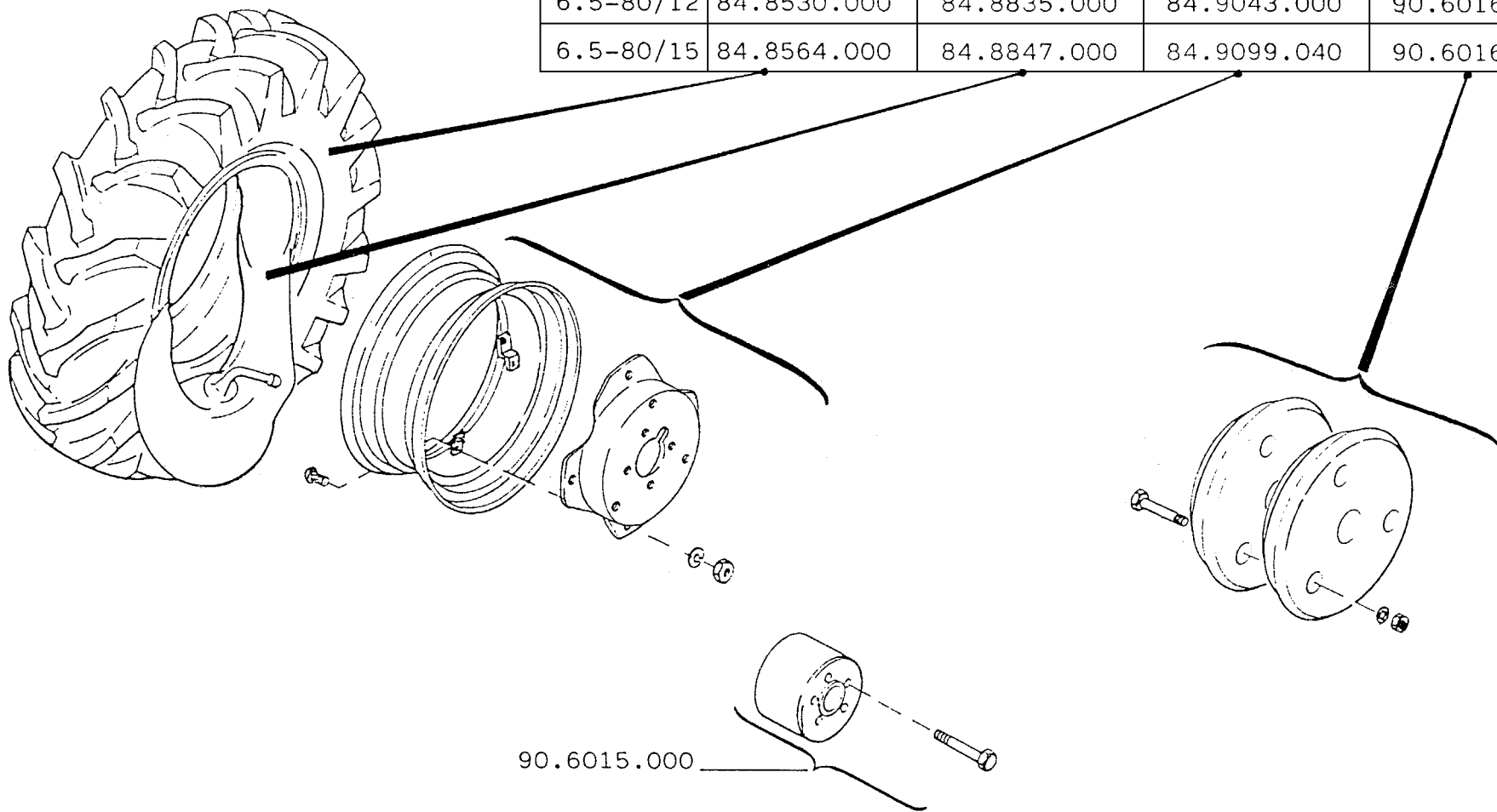

90.6015.000

72S

RUOTE E ACCESSORI

WHEELS AND TOOL KIT
RUEDAS Y ACCESORIOS

ROUES ET ACCESSOIRES
RADER UND WERKZEUGSATZ

DALLA MACCHINA
DE LA MAQUINA
DE LA MACHINE
FROM THE MACHINE
AB DER MASCHINE

N.

14

Rev.
0

09/1991

ATTENZIONE ! PRIMA DI INVERTIRE LA STEGOLA, PORTARE LE LEVE NELLA POSIZIONE INDICATA DALLO SCHEMA.

ATTENTION ! BEFORE TURNING THE HANDLEBAR, SET ALL LEVERS AS SHOWN IN THE DIAGRAM.

ATTENTION ! AVANT DE INVERSER LE MANCHERON, METTRE LES LEVIERS DANS LA POSITION INDIQUEE PAR LE SCHEMA.

ACHTUNG ! BEVOR DEN HOLMEN UMSCHALTEN, STELLEN DIE HEBEL IN DER STELLUNG AUF DEM PLAN BEZEICHNET.

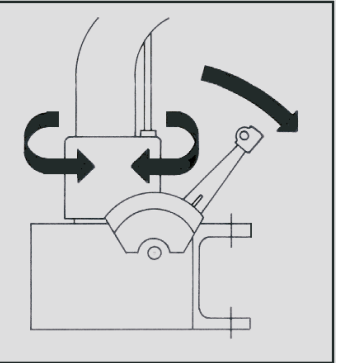

49.7030.109



49.7030.106

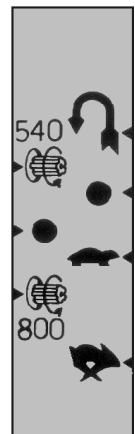

49.7030.107

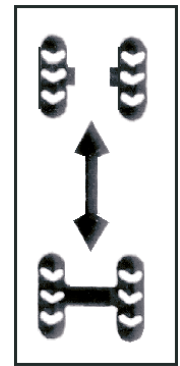

85.3811.000

72S

TARGHETTE ADESIVE

STICKERS
ADHESIVOS

AUTOCOLLANTS
AUFKLEBES

DALLA MACCHINA
DE LA MAQUINA
DE LA MACHINE
FROM THE MACHINE
AB DER MASCHINE

AGGIORNAMENTO
APLAZAMIENTO
MISE A JOUR
REVISION
ANPASSUNG

15

Rev.
1

01/2005

N.

ZENNE

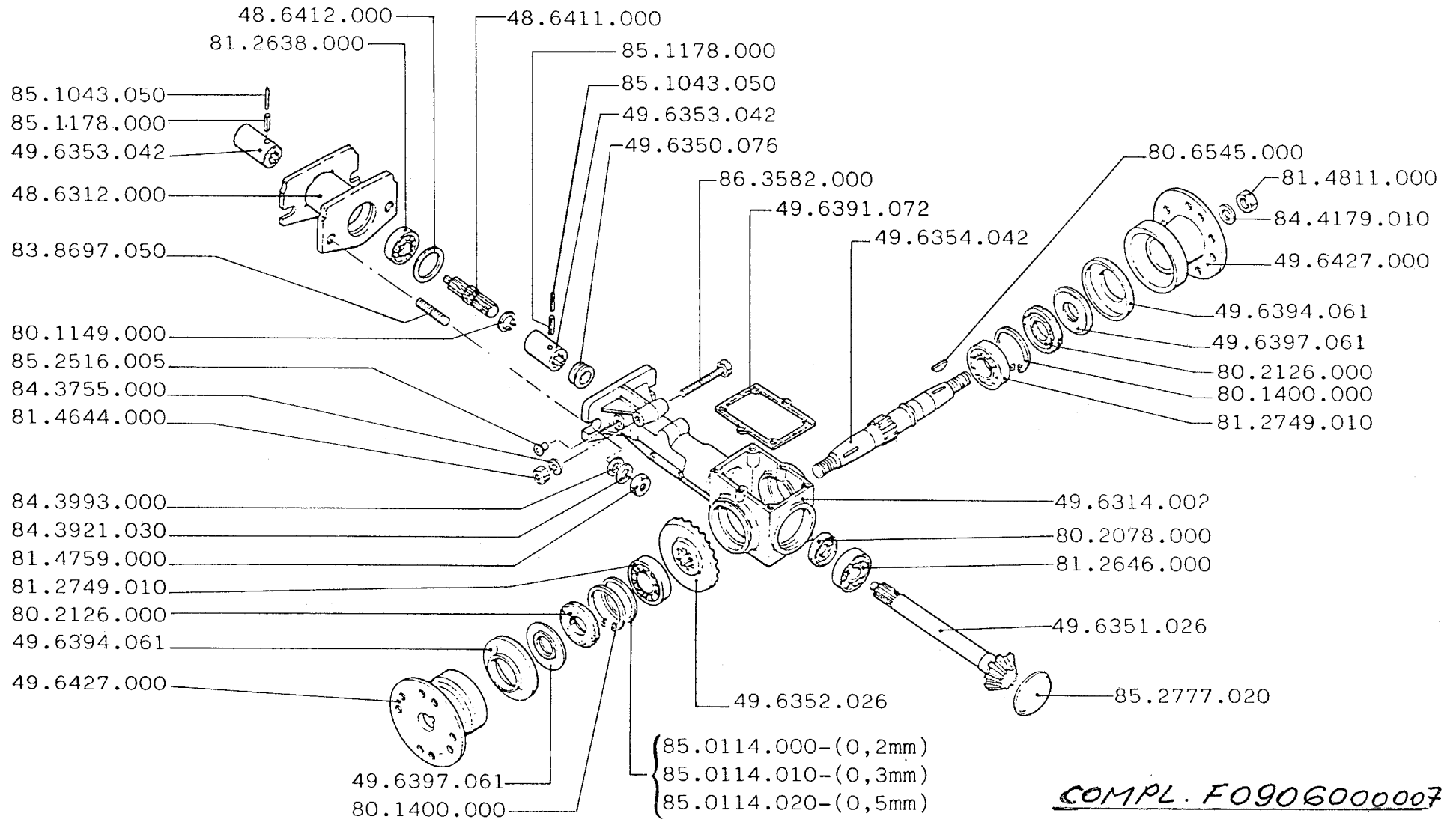

72S

COMANDO FRESA

ROTARY HOE CONTROL
MANDO FRESADORA

COMMANDE FRAISE
FRASERANTRIEB

DALLA MACCHINA
DE LA MAQUINA
DE LA MACHINE
FROM THE MACHINE
AB DER MASCHINE

N.

16 0

09/1991

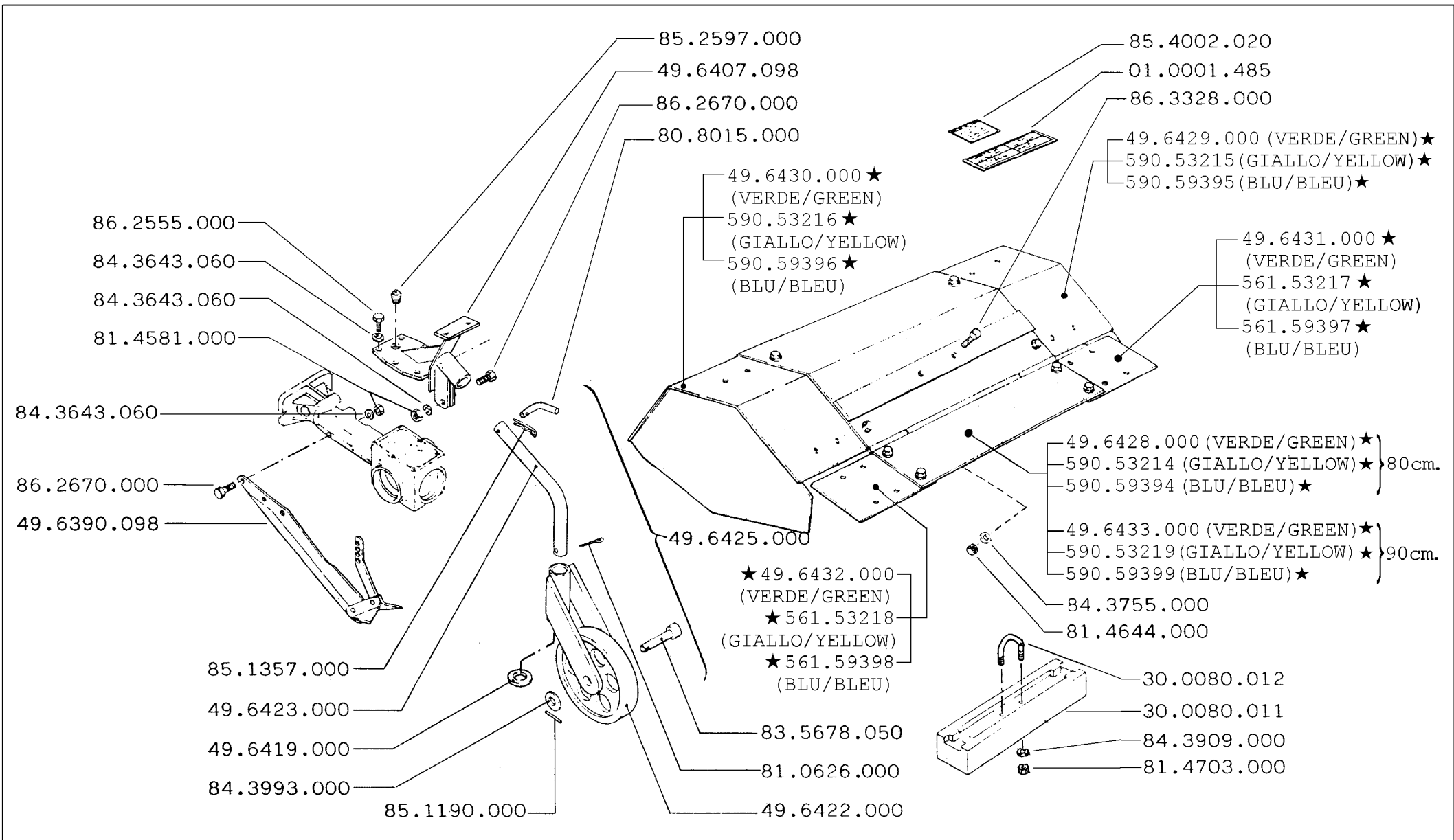

72S

COFANO FRESA E ACCESSORI

ROTARY HOE COVER AND TOOL KIT
CAPO FRESADORA Y ACCESORIOS

CAPOT FRAISE ET ACCESSOIRES
HAUBE FRAISE UND WERKZEUGSATZ

DALLA MACCHINA
DE LA MAQUINA
DE LA MACHINE
FROM THE MACHINE
AB DER MASCHINE

AGGIORNAMENTO

APLAZAMIENTO

MISE A JOUR

REVISION

ANPASSUNG

★N.

17

Rev.

1

01/2005

ZENNE

cm 80

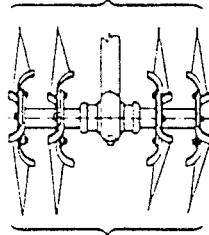

cm 90

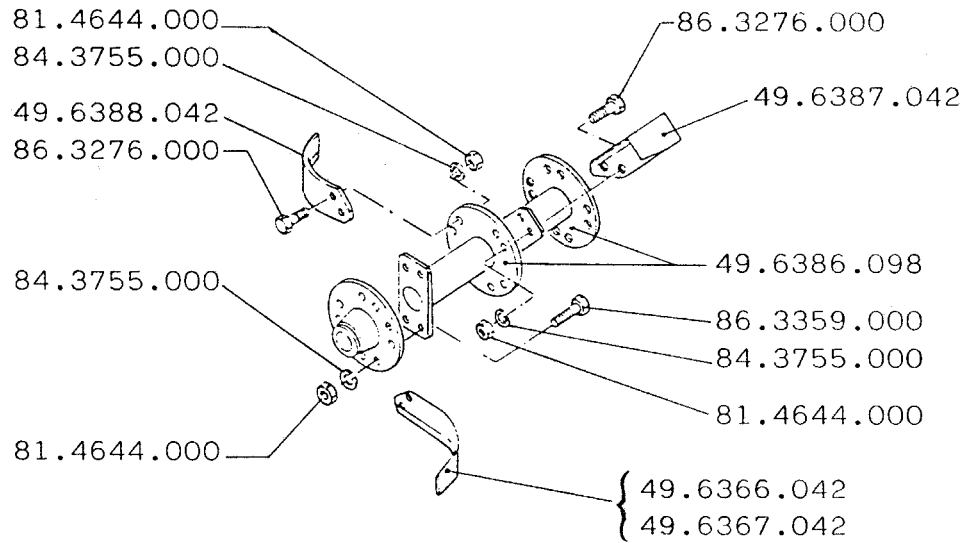
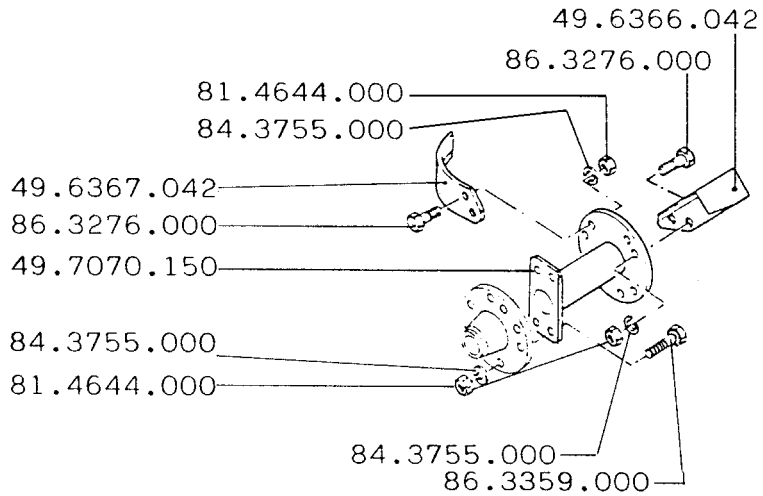
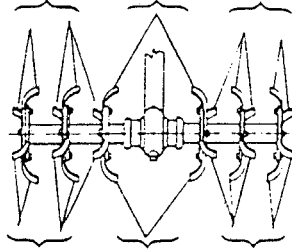

72S

COLTELLI FRESA

ROTARY HOE KNIVES
CUCHILLAS FRESADORA

COUTEAUX FRAISE
FRASERMESSER

DALLA MACCHINA
DE LA MAQUINA
DE LA MACHINE
FROM THE MACHINE
AB DER MASCHINE

N.

18 0

09/1991

ZENNE

COMPLETO
COMPLETE
COMPLET — 924.80744
ENTERO
KOMPLET

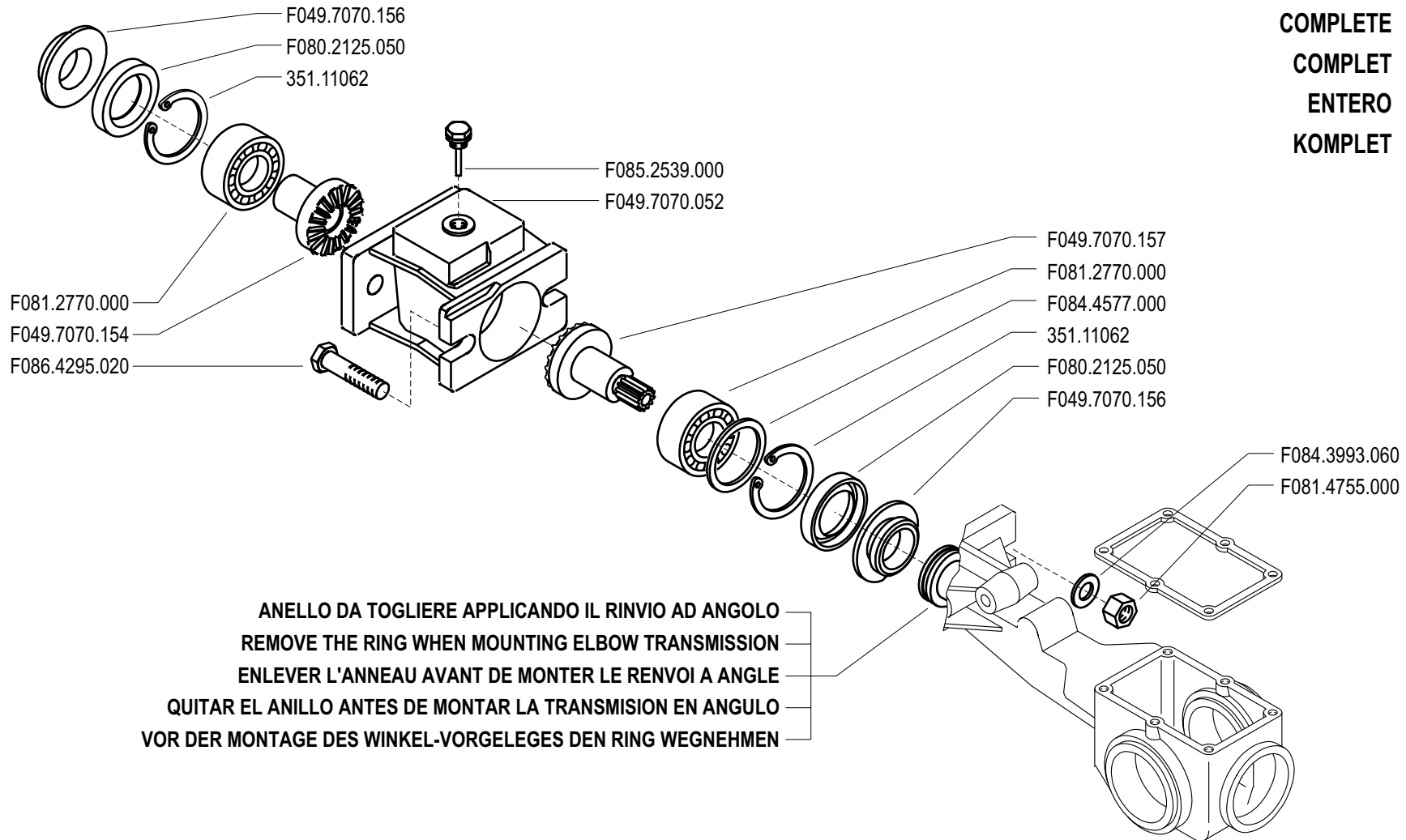

72S

RINVIO AD ANGOLO

ANGLED TRANSMISSION GEAR
 TRANSMISIÓN EN ÁNGULO

RENVOI A ANGLE
 WINKEL VORGELEGE

DALLA MACCHINA
 DE LA MAQUINA
 DE LA MACHINE
 FROM THE MACHINE
 AB DER MASCHINE

N.

19

Rev.
0

04/2003