

# QD Bushings

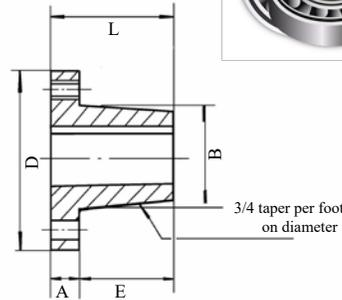

JA-N bushings are reverse mountable

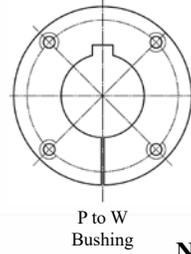
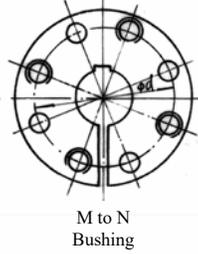
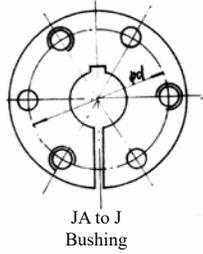

**Note: All bushings include a set screw over the keyway. Except JA.**

QD Bushings - Dimensions (inches)

Bushing	A	B	D	E	L	Ø d bolt Required	Cap Screws Grade 5		Set Screw Size
							Qty.	Size	
JA	5/16	1.375	2	11/16	1	1 21/32	3	10 x 1	-
SH	7/16	1.871	2 11/16	7/8	1 5/16	2 1/4	3	1/4 x 1 3/8	1/4
SDS	7/16	2.187	3 1/8	7/8	1 5/16	2 11/16	3	1/4 x 1 3/8	1/4
SD	7/16	2.187	3 1/8	1 3/8	1 13/16	2 11/16	3	1/4 x 1 7/8	1/4
SK	9/16	2.812	3 7/8	1 3/8	1 15/16	3 5/16	3	5/16 x 2	5/16
SF	5/8	3.125	4 5/8	1 7/16	2 1/16	3 7/8	3	3/8 x 2	3/8
E	7/8	3.834	6	1 7/8	2 3/4	5	3	1/2 x 2 3/4	3/8
F	1	4.437	6 5/8	2 3/4	3 3/4	5 5/8	3	9/16 x 3 5/8	1/2
J	1 1/8	5.148	7 1/4	3 1/2	4 5/8	6 1/4	3	5/8 x 4 1/2	5/8
M	1 1/4	6.500	9	5 1/2	6 3/4	7 7/8	4	3/4 x 6 3/4	3/4
N	1 1/2	7.000	10	6 5/8	8 1/8	8 1/2	4	7/8 x 8	3/4
P	1 3/4	8.250	11 3/4	7 5/8	9 3/8	10	4	1 x 9 1/2	3/4
W	2	10.437	15	9 3/8	11 3/8	12 3/4	4	1 1/8 x 11 1/2	3/4

Bushing	Bore Range-inch	Key Seat-inch	Wt.	Bushing	Bore Range-inch	Key Seat-inch	Wt.
JA	1/2, 9/16.....	1/8 x 1/16	.50	SF	1/2, 9/16.....	1/8 x 1/16	5.45
	5/8, 11/16, 3/4, 13/16, 7/8.....	3/16 x 3/32	.45		5/8, 3/4, 7/8.....	3/16 x 3/32	5.25
	15/16, 1.....	1/4 x 1/8	.35		15/16, 1, 1 1/16, 1 1/8, 1 3/16, 1 1/4.....	1/4 x 1/8	5.00
	1 1/16, 1 1/8, 1 3/16.....	1/4 x 1/16 *	.35		1 5/16, 1 3/8.....	5/16 x 5/32	4.80
	1 1/4.....	No Key	.30		1 3/8†, 1 7/16, 1 1/2, 1 9/16, 1 5/8,.....	3/8 x 3/16	4.50
SH	1/2, 9/16.....	1/8 x 1/16	1.20	1 11/16, 1 3/4.....	3/8 x 3/16	4.25	
	5/8, 11/16, 3/4, 13/16, 7/8.....	3/16 x 3/32	1.20	1 13/16, 1 7/8, 1 15/16, 2, 2 1/16.....	1/2 x 1/4	4.00	
	15/16, 1, 1 1/16, 1 1/8, 1 3/16, 1 1/4.....	1/4 x 1/8	.95	2 1/8, 2 3/16, 2 1/4.....	1/2 x 1/4	3.55	
	1 1/4†, 1 5/16, 1 3/8.....	5/16 x 5/32	.80	2 1/4†.....	5/8 x 5/16	3.50	
	1 7/16, 1 1/2, 1 9/16, 1 5/8.....	3/8 x 1/16 *	.75	2 5/16, 2 3/8, 2 7/16, 2 1/2.....	5/8 x 3/16 *	3.30	
1 11/16.....	No Key	.60	2 9/16, 2 5/8, 2 11/16, 2 3/4.....	5/8 x 1/16 *	2.80		
SDS	1/2, 9/16.....	1/8 x 1/16	1.70	2 13/16, 2 7/8.....	3/4 x 1/16 *	2.45	
	5/8, 11/16, 3/4, 13/16, 7/8.....	3/16 x 3/32	1.65	2 15/16.....	No Key	2.30	
	15/16, 1, 1 1/16, 1 1/8, 1 3/16, 1 1/4.....	1/4 x 1/8	1.45	E	7/8, 15/16.....	3/16 x 3/32	11.45
	1 1/4†, 1 5/16, 1 3/8.....	5/16 x 5/32	1.30		1, 1 1/8, 1 3/16, 1 1/4.....	1/4 x 1/8	11.30
	1 3/8†, 1 7/16, 1 1/2, 1 9/16, 1 5/8, 1 11/16.....	3/8 x 3/16	1.10		1 5/16, 1 3/8.....	5/16 x 5/32	11.00
1 3/4.....	3/8 x 1/8 *	1.00	1 3/8†, 1 7/16, 1 1/2, 1 9/16, 1 5/8,.....		3/8 x 3/16	10.60	
1 13/16.....	1/2 x 1/8 *	1.00	1 11/16, 1 3/4.....		3/8 x 3/16	10.30	
1 7/8, 1 15/16.....	1/2 x 1/16 *	.90	1 13/16, 1 7/8, 1 15/16, 2, 2 1/16,.....	1/2 x 1/4	9.80		
2.....	No Key	.80	2 1/8, 2 3/16, 2 1/4.....	1/2 x 1/4	9.30		
SD	1/2, 9/16.....	1/8 x 1/16	2.00	2 1/4†, 2 5/16, 2 3/8, 2 7/16, 2 1/2.....	5/8 x 5/16	8.70	
	5/8, 11/16, 3/4, 13/16, 7/8.....	3/16 x 3/32	2.00	2 9/16, 2 5/8, 2 11/16, 2 3/4.....	5/8 x 5/16	8.00	
	15/16, 1, 1 1/16, 1 1/8, 1 3/16, 1 1/4.....	1/4 x 1/8	1.80	2 13/16, 2 7/8, 2 15/16, 3, 3 1/8, 3 3/16, 3 1/4.....	3/4 x 1/8 *	7.00	
	1 1/4†, 1 5/16, 1 3/8.....	5/16 x 5/32	1.60	3 5/16, 3 3/8, 3 7/16, 3 1/2.....	7/8 x 1/16 *	5.80	
	1 3/8†, 1 7/16, 1 1/2, 1 9/16, 1 5/8, 1 11/16.....	3/8 x 3/16	1.40				
1 3/4.....	3/8 x 1/8 *	1.20					
1 13/16.....	1/2 x 1/8 *	1.20					
1 7/8, 1 15/16.....	1/2 x 1/16 *	1.00					
2.....	No Key	.80					
SK	1/2, 9/16.....	1/8 x 1/16	3.80				
	5/8, 11/16, 3/4, 13/16, 7/8.....	3/16 x 3/32	3.75				
	15/16, 1, 1 1/16, 1 1/8, 1 3/16, 1 1/4.....	1/4 x 1/8	3.50				
	1 1/4†, 1 5/16, 1 3/8.....	5/16 x 5/32	3.25				
	1 5/16†, 1 3/8†, 1 7/16, 1 1/2, 1 9/16, 1 5/8,.....	3/8 x 3/16	3.00				
1 11/16, 1 3/4.....	3/8 x 3/16	2.75					
1 3/4†, 1 13/16, 1 7/8, 1 15/16, 2, 2 1/16, 2 1/8.....	1/2 x 1/4	2.40					
2 3/16, 2 1/4.....	1/2 x 1/8 *	2.00					
2 1/4†, 2 5/16, 2 3/8, 2 7/16, 2 1/2.....	5/8 x 1/16 *	1.75					
2 9/16, 2 5/8.....	No Key	1.20					

**Note: JA, SH, SDS, SD, SK, SF, E, F, J & M Bushings are machined out of ductile iron.**

\* Shallow Keyseat - Keystock supplied with bushing

† Oversize Key

Note: A rectangular key is supplied with bushings that have shallow keyseats. This key will fit the standard depth keyseat on the shaft and the shallow keyseat on the bushing.

Ordering Example: (JA1.1/16)



**USA Bearings & Belts**  
"We get things moving!"

# QD Bushings

Bushing	Bore Range-inch	Key Seat-inch	Wt.	
<b>F</b>	1, 1 1/8, 1 3/16, 1 1/4.....	1/4 x 1/8	18.60	
	1 3/8.....	5/16 x 5/32	18.60	
	1 7/16, 1 1/2, 1 9/16, 1 5/8, 1 11/16, 1 3/4.....	3/8 x 3/16	18.00	
	1 13/16, 1 7/8, 1 15/16, 2, 2 1/16.....	1/2 x 1/4	16.80	
	2 1/8, 2 3/16, 2 1/4.....	1/2 x 1/4	16.00	
	2 1/4†, 2 5/16, 2 3/8, 2 7/16, 2 1/2, 2 9/16.....	5/8 x 5/16	15.50	
	2 5/8, 2 11/16, 2 3/4.....	5/8 x 5/16	14.20	
	2 13/16, 2 7/8, 2 15/16, 3, 3 1/8, 3 3/16, 3 1/4...	3/4 x 3/8	12.50	
	3 5/16, 3 3/8, 3 7/16, 3 1/2, 3 5/8, 3 11/16.....	7/8 x 3/16 *	10.50	
	3 3/4.....	7/8 x 3/16 *	9.80	
	3 7/8, 3 15/16.....	1 x 1/8 *	9.00	
	4.....	No Key	7.90	
	<b>J</b>	1 7/16, 1 1/2, 1 11/16, 1 3/4.....	3/8 x 3/16	28.00
		1 7/8, 1 15/16, 2, 2 1/16, 2 1/8, 2 3/16, 2 1/4....	1/2 x 1/4	26.50
2 5/16, 2 3/8, 2 7/16, 2 1/2, 2 5/8.....		5/8 x 5/16	24.50	
2 11/16, 2 3/4.....		5/8 x 5/16	23.50	
2 7/8, 2 15/16, 3, 3 1/8, 3 3/16, 3 1/4.....		3/4 x 3/8	21.50	
3 5/16, 3 3/8, 3 7/16, 3 1/2.....		7/8 x 7/16	19.50	
3 5/8, 3 11/16, 3 3/4.....		7/8 x 7/16	17.80	
3 13/16, 3 7/8, 3 15/16.....		1 x 3/8 *	17.50	
4, 4 1/8, 4 3/16, 4 1/4, 4 3/8, 4 7/16, 4 1/2.....		1 x 1/8 *	14.00	
<b>M</b>		1 15/16, 2, 2 3/16, 2 1/4.....	1/2 x 1/4	61.50
		2 3/8, 2 7/16, 2 1/2, 2 5/8, 2 11/16, 2 3/4.....	5/8 x 5/16	57.00
		2 7/8, 2 15/16, 3, 3 1/8, 3 3/16, 3 1/4.....	3/4 x 3/8	53.50
		3 3/8, 3 7/16, 3 1/2, 3 5/8, 3 11/16, 3 3/4.....	7/8 x 7/16	50.00
	3 13/16, 3 7/8, 3 15/16, 4, 4 1/8, 4 3/16, 4 1/4,..	1 x 1/2	45.00	
	4 3/8, 4 7/16, 4 1/2.....	1 x 1/2	40.00	
	4 5/8, 4 11/16, 4 3/4.....	1 1/4 x 5/8	37.00	
	4 7/8, 4 15/16, 5, 5 3/16, 5 1/4, 5 3/8, 5 7/16.....	1 1/4 x 1/4 *	34.00	
	5 1/2.....	1 1/4 x 1/4 *	28.70	
	<b>N</b>	2 15/16, 3, 3 1/4.....	3/4 x 3/8	80.00
3 3/8, 3 7/16, 3 1/2.....		7/8 x 7/16	76.50	
3 5/8, 3 3/4.....		7/8 x 7/16	73.50	
3 7/8, 3 15/16, 4, 4 3/16, 4 1/4, 4 3/8, 4 7/16.....		1 x 1/2	68.00	
4 1/2.....		1 x 1/2	63.00	
4 5/8, 4 3/4, 4 7/8, 4 15/16, 5.....		1 1/4 x 5/8	58.00	
5 3/16, 5 7/16, 5 1/2.....		1 1/4 x 1/4 *	53.00	
5 7/8.....		1 1/2 x 1/4 *	44.00	
6.....		1 1/2 x 1/8 *	44.00	
<b>P</b>	3 3/4.....	7/8 x 7/16	97.00	
	3 15/16, 4 7/16, 4 1/2.....	1 x 1/2	122.00	
	4 7/8, 4 15/16, 5, 5 7/16, 5 1/2.....	1 1/4 x 5/8	115.00	
	5 15/16.....	1 1/2 x 3/4	95.00	
	6, 6 7/16.....	1 1/2 x 1/4 *	95.00	
	6 3/4, 7.....	1 3/4 x 1/8 *	97.00	
<b>W</b>	6, 6 1/2.....	1 1/2 x 3/4	190.00	
	7, 7 1/4, 7 1/2.....	1 3/4 x 7/8	200.00	
	7 3/4, 8, 8 1/2.....	2 x 1/8 *	198.00	

Bushing	Bore Range-mm	Key Seat-mm	Wt.
<b>JA</b>	15, 16	5 x 2.3	.50
	19, 20, 22	6 x 2.8	.40
	24, 25, 28	8 x 3.3	.40
<b>SH</b>	15	5 x 2.3	1.20
	20, 22	6 x 2.8	1.15
	24, 25,	8 x 3.3	1.00
	28, 30	8 x 3.3	.95
	32, 35, 38	10 x 3.3	.80
<b>SDS</b>	15	5 x 2.3	1.50
	20	6 x 2.8	1.50
	24, 25, 28, 30	8 x 3.3	1.50
	32, 35, 38	10 x 3.3	1.30
	40, 42	12 x 3.3	1.10
<b>SD</b>	24, 25, 28, 30	8 x 3.3	1.80
	32, 35, 38	10 x 3.3	1.60
	40, 42	12 x 3.3	1.30
<b>SK</b>	14	5 x 2.3	3.80
	20	6 x 2.8	3.30
	24, 25, 28, 30	8 x 3.3	3.50
	32, 35, 38	10 x 3.3	3.20
	40, 42	12 x 3.3	3.00
	45, 48, 50	14 x 3.8	2.50
	55	16 x 4.3	2.10
	60	18 x 4.4	1.70
<b>SF</b>	28, 30	8 x 3.3	5.00
	32, 35, 38	10 x 3.3	4.70
	40, 42	12 x 3.3	4.50
	45, 48, 50	14 x 3.8	4.00
	55	16 x 4.3	3.60
<b>E</b>	60, 65	18 x 4.4	3.00
	35, 38	10 x 3.3	10.90
	40, 42	12 x 3.3	10.50
	45, 48, 50	14 x 3.8	10.00
	55	16 x 4.3	9.30
<b>F</b>	60, 65	18 x 4.4	8.60
	70, 75	20 x 4.9	7.50
	80	22 x 4.4	6.50
	42	12 x 3.3	17.80
	45, 48, 50	14 x 3.8	17.10
	55	16 x 4.3	16.40
<b>J</b>	60, 65	18 x 4.4	15.20
	70, 75	20 x 4.9	13.50
	80, 85	22 x 5.4	11.00
	90	25 x 5.4	10.30
	50	14 x 3.8	27.00
	55	16 x 4.3	26.20
<b>M</b>	60, 65	18 x 4.8	24.50
	70, 75	20 x 4.9	22.90
	80, 85	22 x 5.4	20.80
	90, 95	25 x 5.4	18.00
	100	28 x 6.4	18.20
<b>N</b>	80	22 x 5.4	54.40
	90	25 x 5.4	50.80
	100	28 x 6.4	46.00
	120	32 x 7.4	37.40
<b>P</b>	90	25 x 5.4	72.30
	100	28 x 6.4	72.30
	120	32 x 7.4	59.75
<b>P</b>	120	32 x 7.4	100.00
	150	36 x 8.4	95.80

**Note: JA, SH, SDS, SD, SK, SF, E, F, J & M Bushings are machined out of ductile iron.**

**Ordering Example: (JA15MM) or (E35MM)**

\* Shallow Keyseat - (Ductile Iron) Keystock supplied with bushing  
† Oversize Key

Note: A rectangular key is supplied with bushings that have shallow keyseats. This key will fit the standard depth keyseat on the shaft and the shallow keyseat on the bushing.

Ordering Example: (F1) or (F1.1/8) or (N5.7/8)