

Adjustable Windshield System

Honda CTX700N / NC700S / CB500F

Please read this entire manual before proceeding with installation.

What is in the box:

- (1) CTX Brackets Kit
- (1) 7/8" crossbar
- (2) M6 x 16 screws
- (2) M6 split lock washers
- (2) M6 flat washers
- (4) Aluminum spacers
- (4) M8 x 50 screws
- (8) M8 flat washers
- (1) Windshield
- (1) Plastic bottom deflector with two M5 well nuts inserted
- (2) M5 T-screws
- (2) plastic flat washers
- (4) M5 x 25 Philips screws
- (4) M5 black plastic washers
- (4) 4 rubber washers



This MadStad system attaches above your handlebar clamps using aluminum spacers and longer bolts. Your handlebars do not need to come loose as you can install these brackets one side at a time.

Bracket Installation:

STEP 1 – Pre-assemble your crossbar onto one of the MadStad bracket assemblies. Install the side of the crossbar which has the set pin as shown in the diagram here. The pin sits in the slot (on either bracket assembly, it doesn't matter) to prevent the crossbar from rotating. The finished assembly should look like the photo below.

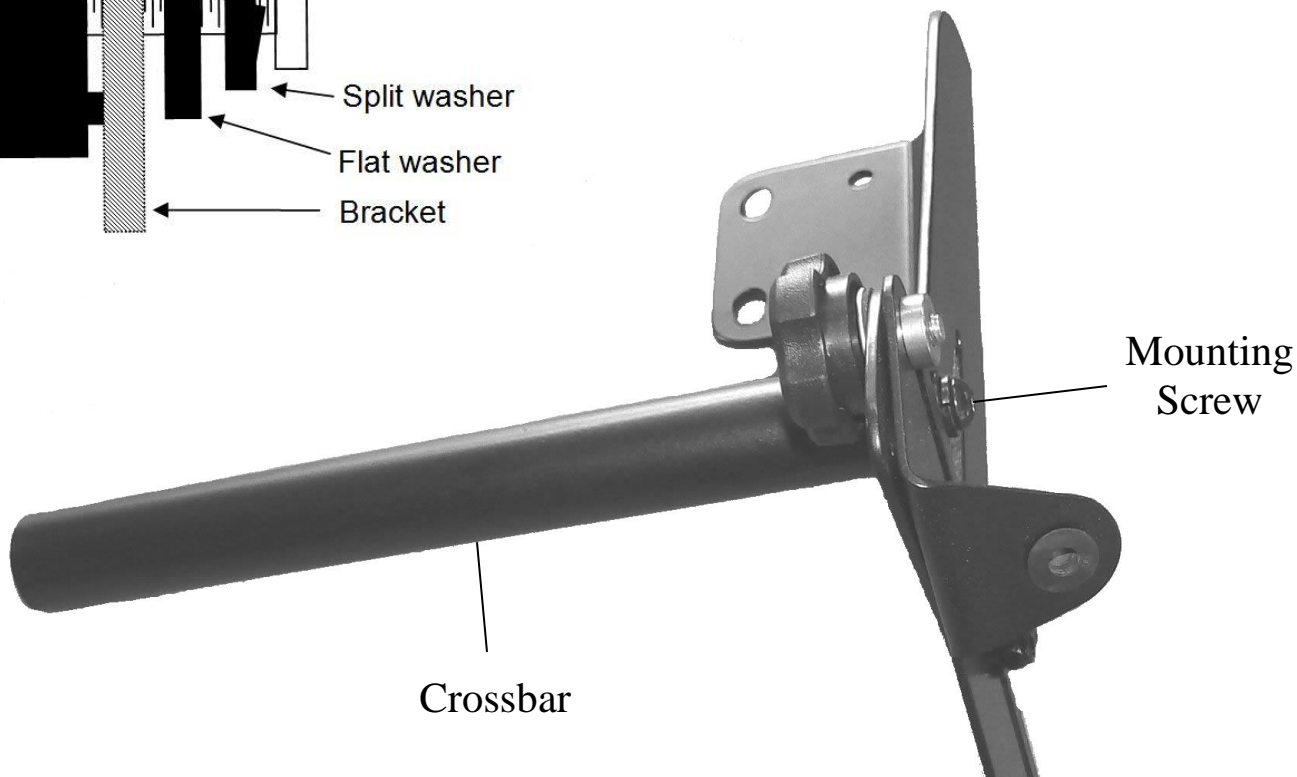
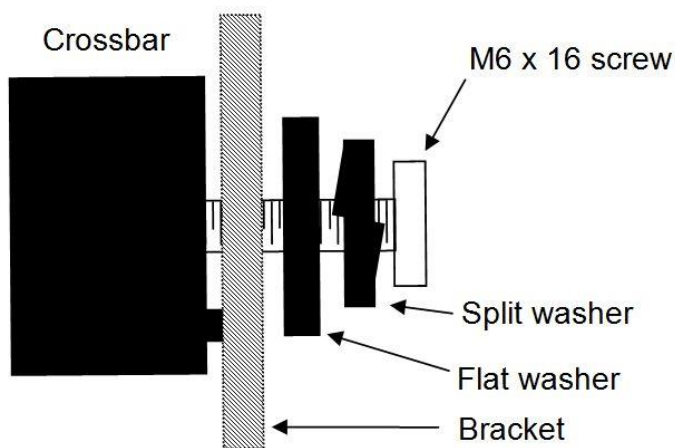
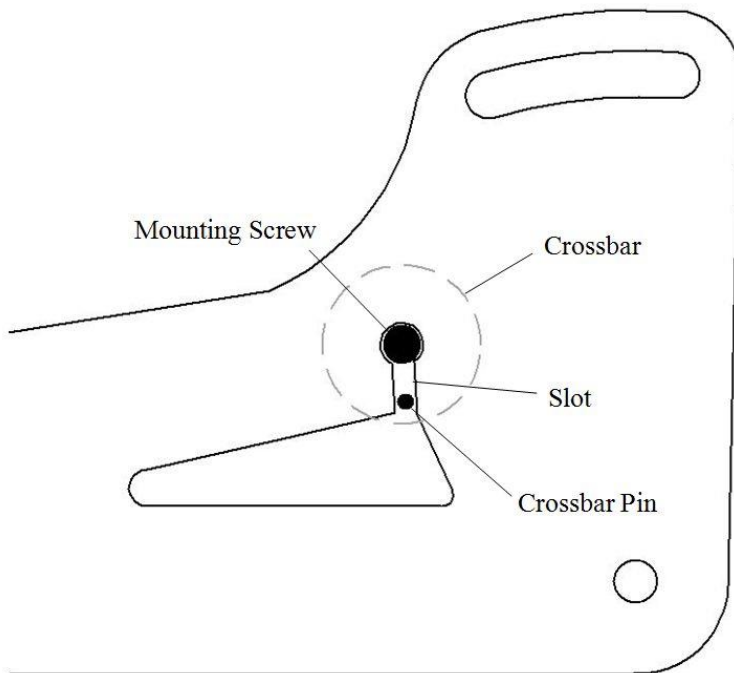

STEP 2 - Pry off all four plastic bolt caps that are on your handlebar bolts. You will not need these, but save them.

STEP 3 – Using a 6mm Allen wrench, remove the two handlebar clamp bolts ON ONE SIDE ONLY and DO NOT remove the top clamps, only the bolts. (If you remove all four handlebar clamp bolts or your bars will come loose!)

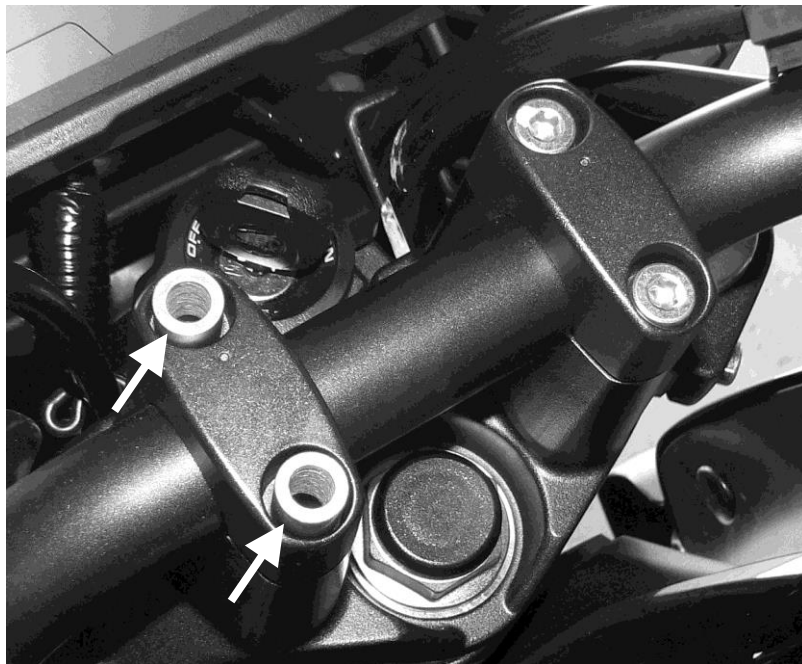

STEP 4 – Set two of the spacers provided in your kit into the two holes in the now-open top clamp, as seen in the photo above. Put one M8 flat washer on top of each spacer. To keep it from slipping off, put a dab of Vaseline or similar thick grease on top of the spacer so that the flat washer will stick to it and not slide off.

STEP 5 – Take this the bracket with crossbar and insert two of the new M8 bar clamp bolts provided, along with flat washers, into the mounting holes. Set it over the top of the spacers and washers, and bolt it down.

***NOTE:** Tighten the front bolt completely first, then tighten the back bolt to factory specifications.*



STEP 6 – Repeat steps 3, 4 and 5 for the other half of the brackets. Don't fully tighten the bar clamp bolts until you fasten the crossbar to the second side. Use the same hardware configuration for this as you did on the other side of the crossbar. Once the crossbar is installed, then finish tightening down the bar clamp bolts same as you did in Step 5.

STEP 7 – Windshield Installation

1. Pre-install the Truss screws & washers into the windshield holes as shown in the image below.
2. Once all four of the screws are in place, gently guide the screws into the Well Nuts in the brackets until all four are set.
3. Hand tighten the Truss screws until they swell up behind the bracket and are firmly holding the windshield.

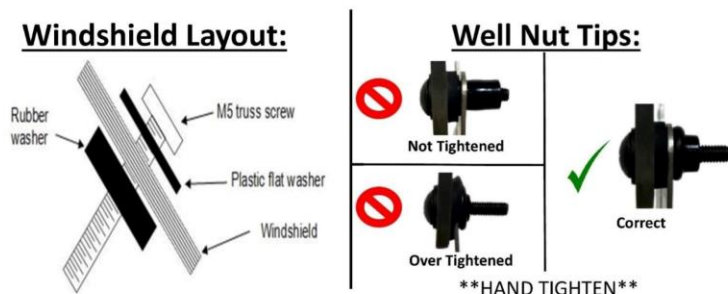

STEP 8 – Install the baffle plate. This goes underneath the MadStad brackets and is fastened with the T-screws from above, as seen in the photo below.

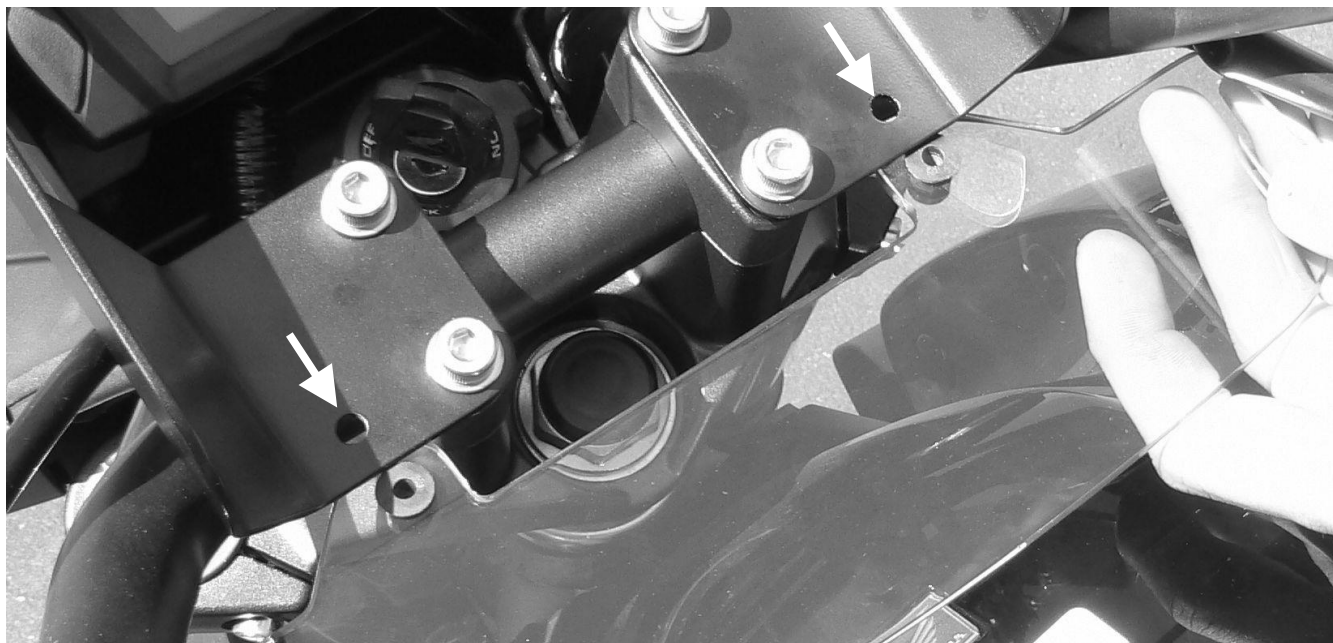

Adjusting the MadStad Knob Brackets

The knob screws release the brackets allowing the windshield to slide and tilt. These knob screws must always be tightened securely before riding. **DO NOT** attempt to adjust the brackets while riding! You must come to a complete stop before making adjustments. Also make sure that you do not set the windshield in such a way that causes your handlebars or hand guards (if installed) to hit the windshield when turning, or before reaching full lock.

To make adjustments, loosen the knobs 1-2 turns and set the windshield so the top edge is at about your chin level as you look straight ahead while seated on the bike. Set the angle at approximately 60 degrees (roughly the same angle as your forks). You can also use the angle diagram on the back page of this manual as a guide. Tighten the knobs and go for a ride to see if you now have smooth airflow over and around your helmet. Do this on a calm day if at all possible; windy days make it hard to judge the airflow. Don't ever try to adjust the brackets while in motion!

To try a different windshield position, bring the motorcycle to a complete stop and out of traffic. Loosen the two knob screws and tilt the windshield forward or back 2-3 degrees or so, and/or adjust it up or down if necessary. Re-tighten the knobs and go for another ride.

Continue experimenting with different positions at different speeds until you find a combination of height and rake angle that eliminates buffeting and gives a smoother ride. You may have more than one favorite position, for example shield tilted forward on cooler days, and shield tilted back for hot days to let more air to your body.

Bottom deflector

The bottom deflector is designed to block a jet of air that shoots up from in front of the fuel tank and hits you in your body. You do not have to use this deflector, however most likely it will give you a calmer and quieter ride, particularly at highway speeds. Using the T-screws provided you can easily remove or install it at will.

PIVOT SCREWS

The MadStad mount has a pivot screw on each set of brackets, located near the center of the bottom bracket. A nylon lock nut keeps the screw snugly in place, yet allows the brackets to slide back and forth. It is adjusted at the factory to have a minimum of play yet still allow the brackets to move.

If for some reason you wish to adjust the tightness of this pivot screw or move it to an alternate pivot position, use a 4mm Allen wrench along with a 10mm socket or crescent wrench to make the adjustment. If you tighten the lock nut completely you will not be able to slide the brackets.

Notes on Windshield Angle

Most windshields work best when set at a 55-60 degree angle. We have provided an angle guide **on the back page of this manual** so that you can check and see if your shield is set somewhere in this range.

To check your shield angle, your bike should be in an upright position either on a center stand or held up by a helper. Set the spine (folded edge) of the manual against the front of the shield. If the large arrow marked 60° is pointing straight up, then your shield is at a 60 degree angle. (See diagram on Page 5.) A little farther back and your angle would somewhere between 55 and 60 degrees. Anywhere in this range is fine for your initial test ride. On some bikes a more vertical angle works better, so don't be afraid to experiment later if tilting the shield back doesn't seem to be ideal.

Disclaimer

Neither MadStad Engineering nor its owners shall be liable for any damages, consequential or inconsequential, resulting from the use of our products. Installation of any of our products constitutes acceptance of these terms.

It is the responsibility of the user to make sure all fasteners are tightened securely, the windshield is mounted properly and the adjustment knobs are tightened snugly before putting the motorcycle in motion. MadStad systems ARE NOT intended to be adjusted while the vehicle is in motion; you must pull over out of the way of traffic and come to a complete stop before making any changes. The user must never place the windshield in such a position as to interfere with the safe and complete movement of the handlebars and controls.

Returns and Warranty

MadStad adjustable brackets carry a lifetime warranty against manufacturing defects. This does not include cosmetic issues nor any parts that inherently wear out or degrade over time such as rubber and plastic parts. Windshields, deflectors, and other similar plastic parts are warranted for 1 year against manufacturing defects, not against cosmetic issues or issues related to normal wear and tear. Please visit our website for further details.

MadStad Engineering, Inc.

1451 E. Jefferson St.
Brooksville, FL 34601
Phone: 352-848-3646

Web Site: <http://www.madstad.com>

Email: support@madstad.com

Thank you for your support, and ride safely!

