

Lodestar electric chain hoist

INTRODUCING THE NEXT GENERATION OF
LODESTAR WITH CAPACITIES OF UP TO 3 TONS.

STANDARD FEATURES

CAPACITIES: 1/8 TO 3 TONS

**FABRIC CHAIN CONTAINER
& RIGID HOOK SUSPENSION**
Standard on every Lodestar

LIFETIME WARRANTY
The industry's best warranty against
manufacturing and material defects.

METRIC RATED

CSA/US
National Recognized
Testing Laboratory (NRTL)

MADE IN THE USA



SPECIFICATIONS

	Capacity (tons)	Product Code		Model	Hoist Lifting Speed (FPM)	Motor HP	Reeving	Weight (lbs.)	
		**Rigid Hook Suspension & Chain Container						115-1-60	230/460 3-60
		115-1-60	230/460 3-60						
Single Speed 10' Lift	1/8	2702NH	2705NH	A	32.0	1/4	1	54	60
	1/8	2712NH	2715NH	AA	60.0	1/2	1	67	64
	1/4	2722NH	2725NH	B	16.0	1/4	1	53	61
	1/4	2732NH	2735NH	C	32.0	1/2	1	61	64
	1/2	2742NH	2745NH	E	8.0	1/4	2	71	69
	1/2	2752NH	2755NH	F	16.0	1/2	1	61	65
	1/2	3512NH	3515NH	J	32.0	1	1	110	110
	1/2	-	3545NH	JJ	64.0	2	1	—	117
	1	2762NH	2765NH	H	8.0	1/2	2	72	73
	1	3522NH	3525NH	L	16.0	1	1	113	110
	1	-	3555NH	LL	32.0	2	1	—	117
	2	3532NH	3535NH	R	8.0	1	2	131	130
	2	-	3565NH	RR	16.0	2	2	—	135
3	9501NH	9505NH	RT	5.5	1	3	158	158	
3	-	9508NH	RRT	11.0	2	3	—	162	
Single Speed 15' Lift	1/8	3101NH	3103NH	A	32.0	1/4	1	59	64
	1/8	3111NH	3113NH	AA	60.0	1/2	1	67	79
	1/4	3121NH	3123NH	B	16.0	1/4	1	61	64
	1/4	3131NH	3133NH	C	32.0	1/2	1	66	75
	1/2	3141NH	3143NH	E	8.0	1/4	2	70	80
	1/2	3151NH	3153NH	F	16.0	1/2	1	67	72
	1/2	4212NH	4214NH	J	32.0	1	1	118	115
	1/2	-	4244NH	JJ	64.0	2	1	—	123
	1	3161NH	3163NH	H	8.0	1/2	2	80	85
	1	4222NH	4224NH	L	16.0	1	1	120	114
	1	-	4254NH	LL	32.0	2	1	—	122
	2	4232NH	4234NH	R	8.0	1	2	140	138
	2	-	4264NH	RR	16.0	2	2	—	144
3	9502NH	9506NH	RT	5.5	1	3	174	171	
3	-	9509NH	RRT	11.0	2	3	—	176	
Single Speed 20' Lift	1/8	3102NH	3104NH	A	32.0	1/4	1	64	68
	1/8	3112NH	3114NH	AA	60.0	1/2	1	72	74
	1/4	3122NH	3124NH	B	16.0	1/4	1	64	72
	1/4	3132NH	3134NH	C	32.0	1/2	1	69	76
	1/2	3142NH	3144NH	E	8.0	1/4	2	80	88
	1/2	3152NH	3154NH	F	16.0	1/2	1	71	76
	1/2	4213NH	4215NH	J	32.0	1	1	124	124
	1/2	-	4245NH	JJ	64.0	2	1	—	128
	1	3162NH	3164NH	H	8.0	1/2	2	86	90
	1	4223NH	4225NH	L	16.0	1	1	124	119
	1	-	4255NH	LL	32.0	2	1	—	127
	2	4233NH	4235NH	R	8.0	1	2	148	148
	2	-	4265NH	RR	16.0	2	2	—	156
3	9503NH	9507NH	RT	5.5	1	3	187	184	
3	-	9510NH	RRT	11.0	2	3	—	194	

Fabric Chain Containers included on all models for up to 20 ft. Lift

*Hoist only without suspension & chain container must be ordered through the configurator.

**Rigid hook suspension & fabric chain container are standard with hoist codes listed above.

When ordering, specify code number(s), model, capacity, beam size, power supply, suspension, lift, extra control cord or power cord, (if required) and type of electrification (if required).

CSA APPROVED†

† Hook Suspension models only.

OPTIONAL FEATURES

DOUBLE DC BRAKE

Two independent acting DC Brakes for redundant braking. Field Installation Kit available.

AC ELECTRIC BRAKE

VARIABLE SPEED DRIVE (VFD) OR TRADITIONAL 2 SPEEDS AVAILABLE

PRIMARY & SECONDARY TRANSFORMER FUSING

ROTATABLE LIMIT SWITCH

Designed for quick reset of limit position

BLACK PHOSPHATE OR STAINLESS STEEL LOAD CHAIN

METAL & STAINLESS STEEL CHAIN CONTAINERS

Lodestar electric chain hoist - Specifications

SPECIFICATIONS

	Capacity (tons)	Product Code		Model	Hoist Lifting Speed (FPM)	Motor HP	Reeving	Weight (lbs.)	
		**Rigid Hook Suspension & Chain Container						230-3-60	460-3-60
		230-3-60	460-3-60						
Two Speed 10' Lift	1/8	2707NH	2708NH	A2	10/32	1/4	1	67	73
	1/8	2717NH	2718NH	AA2	20/60	1/2	1	74	75
	1/4	2727NH	2728NH	B2	5/16	1/4	1	67	73
	1/4	2737NH	2738NH	C2	10/32	1/2	1	73	74
	1/2	2747NH	2748NH	E2	2.5/8	1/4	2	76	82
	1/2	2757NH	2758NH	F2	5/16	1/2	1	74	74
	1/2	3502NH	3503NH	J2	10/32	1	1	116	117
	1/2	3549NH	3550NH	JJ2	21/64	2	1	130	130
	1	2767NH	2768NH	H2	2.5/8	1/2	2	83	84
	1	3504NH	3505NH	L2	5/16	1	1	116	117
	1	3553NH	3554NH	LL2	10/32	2	1	130	131
	2	3506NH	3507NH	R2	2.5/8	1	2	134	135
	2	3561NH	3562NH	RR2	5/16	2	2	149	149
	3	9511NH	9513NH	RT2	1.75/5.5	1	3	161	176
	3	9512NH	9514NH	RRT2	3.5/11	2	3	176	174
Variable Frequency Drive	1/8***	2709NH	2710NH	A	32.0	1/4	1	65	65
	1/4***	2726NH	2729NH	B	16.0	1/4	1	65	65
	1/4***	2734NH	2736NH	C	32.0	1/2	1	65	65
3 - Step Infinitely Variable Control	1/2***	2730NH	2731NH	F	16.0	1/2	1	65	65
	1/2***	3635NH	3636NH	J	32.0	1	1	110	110
	1/2***	3642NH	3643NH	JJ	64.0	2	1	110	110
	1***	3625NH	3626NH	L	16.0	1	1	110	110
	1***	3644NH	3645NH	LL	32.0	2	1	110	110
6 to 1 Speed Ratio	2***	3632NH	3633NH	R	8.0	1	2	110	110
	2***	3646NH	3647NH	RR	16.0	2	2	110	110
10' Lift	3***	9531NH	9534NH	RT	5.5	1	2	110	110
	3***	9539NH	9540NH	RRT	11.0	2	2	110	110

Fabric Chain Containers included on all models for up to 20 ft. Lift

** Rigid hook suspension & fabric chain container are standard with hoist codes listed above.

*** Not CSA Approved.

Control Cord drop is 4 ft. less than Lift.

VFD units are factory set for 3-Step Infinitely Variable Control and include 3-Step Control Station and 115V interface card as standard.

CSA APPROVED†

† Hook Suspension models only.

Less maintenance & easier inspection

- Heavy Duty DC Brake is designed for a long service life. Brake location allows for quick access and easy inspection.
- Lifetime grease-lubricated Gear Box means no oil change out is required. Precision gears provide better wear and longer life.
- Clutch located outside the Gear Box allows for easy access which eliminates the need for complete disassembly and reduces downtime.

Improved serviceability

- Easy access to the Clutch, Motor, Electrical Control Panel and Brake Assembly.

Longer service life

Lifetime grease-lubricated Gear Box and helical gearing ensures efficient operation. Heavy duty rated motors. Hoist workmanship backed by a lifetime warranty.

Quieter operation

80% reduction in sound pressure as compared to the classic Lodestar.

HOIST SUSPENSIONS

	Product Code	Models	Weight (lbs.)
Rigid Hook**	2788NH	A-AA-B-C-F	2
	2789NH	E-H	4
	3651NH	J-L-JJ-LL	4
	3658NH	R-RR	8
	9559NH	RT-RRT	7
Rigid Latchlok Hook	2790NH	A-AA-B-C-F	3
	3652NH	J-L-JJ-LL	5
Swivel Hook	2792NH	A-AA-B-C-F	2
	2793NH	E-H	4
	3661NH	J-L-JJ-LL	4
	3660NH	R-RR	8
	9557NH	RT-RRT	7
Swivel Latchlok Hook	2796NH	A-AA-B-C-F	3
	3662NH	J-L-JJ-LL	5
	3663NH	R-RR	9
Rigid Lug for Low Headroom Trolley	2778NH	A-AA-B-C-F	2
	2779NH	E-H	3
	3677NH	J-L-JJ-LL	4
	3668NH	R-RR	6
	9561NH	RT-RRT	5
Rigid Lug for Motor Driven Trolley	2992NH	A-AA-B-C-F	2
	2993NH	E-H	3
	3679NH	J-L-JJ-LL	4
	3668NH	R-RR	6
	9561NH	RT-RRT	5

Improved load safety

Clutch is located outside the load path which prevents slipping of the load in an overload condition when brake is not powered.

Improved chain life

5 Pocket Lift Wheel provides better chain and lift wheel engagement for smoother lifting and reduced vibration — which equates to less wear and a longer chain life. Zinc plating to protect chain from environmental conditions.

Easy access control panel

With finger-safe wiring and plug and play connectors, the Control Panel allows for quick voltage change, access to terminal strips and simple fuse installation.

Exceeds H4 requirements

Lodestar exceeds H4 requirements, engineered for high duty cycles and the toughest applications.

Eco-friendly

Lifetime grease-lubricated Gear Box means no changing and disposing of hazardous oil. Documented RoHS compliance. Shipped in boxes made of recycled material.

Lodestar electric chain hoist (2-ton, single-reeved)

THE CM® LODESTAR® IS NOW AVAILABLE AS AN ECONOMICAL 2-TON, SINGLE-REEVED UNIT THAT'S IDEAL FOR A VARIETY OF INDUSTRIAL LIFTING APPLICATIONS. AND, BECAUSE IT'S A SINGLE REEVED UNIT, THE DESIGN PREVENTS THE LOWER HOOK BLOCK FROM CAPSIZING AND DAMAGING THE HOIST.

STANDARD FEATURES

LESS MAINTENANCE & EASIER INSPECTION

- Brake location allows for quick access and easy inspection.
- Lifetime grease-lubricated Gear Box means no oil change is required.
- Clutch located outside the Gear Box allows for easy access which eliminates the need for complete disassembly and reduces downtime.

IMPROVED SERVICEABILITY

Easy access to the Clutch, Motor, Electrical Control Panel and Brake Assembly.

LONGER SERVICE LIFE

- Heavy-duty DC brake is designed for a long service life.
- Lifetime grease-lubricated Gear Box and helical gearing ensures better wear and smooth operation.
- Heavy-duty rated motors.

IMPROVED LOAD SAFETY

Clutch is located outside the load path preventing slipping of the load in an overload condition when the brake is not powered.

IMPROVED CHAIN LIFE

5-Pocket Lift Wheel provides better chain and lift wheel engagement for smoother lifting and reduced vibration equating to less wear and a longer chain life. Zinc plating protects chain from environmental conditions.

OPTIONAL FEATURES

DOUBLE DC BRAKE

Two independent acting DC Brakes for redundant braking. Field installation kit available.

VARIABLE SPEED DRIVE (VFD)

PRIMARY & SECONDARY TRANSFORMER FUSING

ROTATABLE LIMIT SWITCH

Designed for quick reset of limit position.

METAL CHAIN CONTAINERS

EASY ACCESS CONTROL PANEL

Finger-safe wiring and plug-and-play connectors on the Control Panel allow for quick voltage change, easy access to terminal strips and simple fuse installation.

ZINC PLATED LOAD CHAIN

Designed and manufactured in the USA by Columbus McKinnon. 10 millimeter, zinc plated Star Grade load chain protects against corrosion.

ADJUSTABLE LIMIT SWITCH

Easy-to-adjust screw limit switch automatically stops the hook at any predetermined point when either lifting or lowering, preventing overtravel.

OVERLOAD PROTECTOR

Helps prevent lifting of dangerous overloads.

METRIC RATED

LIFETIME WARRANTY

The industry's best warranty against manufacturing and material defects.

FABRIC CHAIN CONTAINER

Standard up to 20 ft lift.

RIGID HOOK SUSPENSION



Lodestar electric chain hoist (2-ton, single-reeved) - Specifications

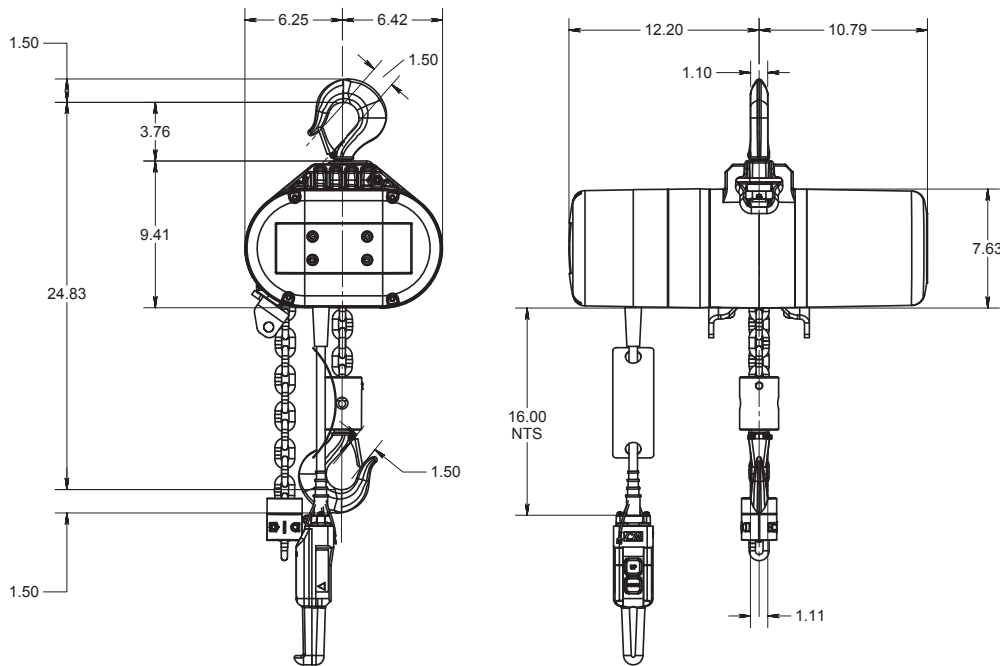

Dimensions (in inches) are RRS model CM Lodestar 2 Ton Single Reeved with Swivel Latch Type Hook Suspension.

For a complete list of dimensions for a specific model type/configuration, visit www.cmworks.com/Library/

SPECIFICATIONS

	Capacity (tons)	Voltage	Product Code**	Model	Hoist Lifting Speed (FPM)	Motor HP	Reeving	Weight (lbs.)
			**Rigid Hook Suspension & Chain Container					
Single Speed Less Chain	2 Ton	230/460-3-60	3565S1LC	RRS	16	2	1	141
Single Speed 10' Lift	2 Ton	230/460-3-60	3565S1	RRS	16	2	1	156
	2 Ton	575-3-60	9280S1	RRS	16	2	1	156
Single Speed 15' Lift	2 Ton	230/460-3-60	4264S1	RRS	16	2	1	164
Single Speed 20' Lift	2 Ton	230/460-3-60	4265S1	RRS	16	2	1	172
Variable Frequency Drive 10' Lift	2 Ton	230-3-60	3646S1	RRS	16	2	1	161
	2 Ton	460-3-60	3647S1	RRS	16	2	1	162

Fabric Chain Containers included on all models for up to 20 ft. Lift

*Hoist only without suspension & chain container must be ordered through the configurator.

**Rigid hook suspension & fabric chain container are standard with hoist codes listed above.

When ordering, specify code number(s), model, capacity, beam size, power supply, suspension, lift, extra control cord or power cord, (if required) and type of electrification (if required).

STAR GRADE LOAD CHAIN, BULK CHAIN

Product Code	Size	Finish	Feet per Drum
85960EN250	10 mm	Zinc Plated	250
85960EN500			500
85960EN1000			1000

CHAIN CONTAINERS

Fabric Chain Containers included on all New Lodestar models up to 20 ft. Lift

Product Code	+ Bucket Length (in.)	Weight (lbs.)	Maximum Length of Lift (ft.)
CANVAS			
10001562	10	4.0	20
10001568	13	4.1	30
10001569	16	4.2	40
10001570	18	4.3	50
10001571	20	4.4	60
METAL			
10001563	10	12.4	30
10001564	15	15.7	55
10001565	20	19.0	80
10001566	25	22.4	105
10001567	30	25.7	130

HOIST SUSPENSIONS

Type	Product Code	Use for Models	Weight (lbs.)
Swivel Hook	10001574	RRS	5.4
	10001573	RRS	5.6
Rigid Hook**	10001573X (cross mount)	RRS	5.6
	10001577	RRS	3.6
Rigid Lug	10001577X (cross mount)	RRS	3.6
	10001575	RRS	5.2
Rigid Latchlok Hook	10001575X (cross mount)	RRS	5.2
	10001576	RRS	5.0
Swivel Latchlok Hook	10001578	RRS	-
Universal Trolley Lug	10001578X (cross mount)	RRS	-

CSA APPROVED

Single speed hook suspended models are CSA Approved as standard. For trolley-mounted models, please contact your CMCO representative.