

Cabinet

Type	TMF Freezer
Finish	Powdercoated galvanised steel
Insulation	Type PU foam
	Thickness (mm) 50 Blowing Agent Cyclo-iso pentane (C5H10/C5H12)
Doors	Type Glass swing door (triple-glazed, heated, argon-filled)
	Height (mm) 1570 Opening Size Width (mm) 436
Shelving	Fifteen adjustable height plastic-coated wire shelves 10 × side shelf (502W × 467D), 5 × middle shelf (571W × 467D)
Lighting	Sign 1 × 24 W, 1590 mm LED strip Interior * 3 × 20 W, 1400 mm LED strip side light

Dimensions†

	External	Internal	Packaging
Width (mm)	1705	1605	TBC
Depth (mm)	745	554	TBC
Height (mm)	2210	1570	TBC
Weight (kg)	(castors) TBC		TBC
Capacity (L)	1396		
Footprint (m²)	1.27		

Ventilation (mm)

Top 300	Sides	Not required	Rear	10
----------------	--------------	--------------	-------------	----

Dimensional Tolerances

† Allow for dimensional tolerances when installing the cabinet(s).

Linear dimensions At each joint	Single cabinet		Multiple cabinets At each end wall
	Less than 1 metre	±5 mm ±5 mm	
Less than 1 metre	±5 mm ±5 mm	+15 mm	
More than 1 metre	-5 mm to +10 mm	-5 mm to +10 mm	+15 mm

Performance

Product Temperature Range (°C)	-18 to -21 (adjustable* from -12 to -26)
Maximum Ambient Temperature (°C)	40
Sound Level (dB(A))	Standard 67
	Hush Mode * 65

Greenhouse and Energy Minimum Standards (GEMS)

Star Rating	2
Product Temperature Class	L1 (less than -18°C)
Total Energy Consumption	31.35 kWh/24 h
Annual Running Costs	\$3433 (@ \$0.30/kWh)

Electrical

Supply	220-240 volts a.c., 50 Hz, single phase supply
Cord	2.3 m power cord with 3-pin, 15 amp plug
Current draw (A)	11.5

Refrigeration

Controller	SCS Connect (SKOPE-connect™ compatible)
System Type	Removable cartridge
Cartridge Weight (kg)	47.5 × 2
Refrigerant/Charge	R290/112 × 2 g
Nominal Capacity (W)	1504 (2 × 752)
Heat Rejection (W)	Average 1305 Peak 1540 Hot gas
Defrost Type	No plumbing required
Drainage	

* Accessible via the free SKOPE-connect™ app.



TMF1500N-AC
on the SKOPE website

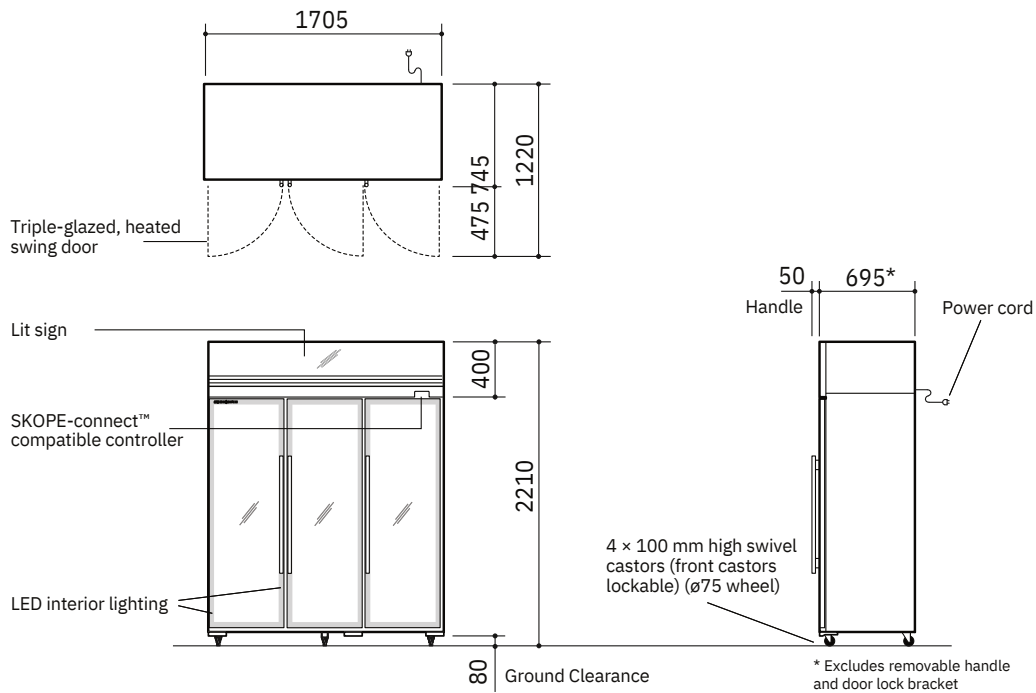

Cabinet

Type	TMF Freezer
Finish	Powdercoated galvanised steel
Insulation	Type PU foam Thickness (mm) 50 Blowing Agent Cyclo-iso pentane (C5H10/C5H12)
Doors	Type Glass swing door (triple-glazed, heated, argon-filled) Height (mm) 1570 Opening Size Width (mm) 436
Shelving	Fifteen adjustable height plastic-coated wire shelves 10 x side shelf (502W x 467D), 5 x middle shelf (571W x 467D)
Lighting	Sign 1 x 24 W, 1590 mm LED strip Interior * 3 x 20 W, 1400 mm LED strip side light

Dimensions†

	External	Interna	Packe
Width (mm)	1705	1605	d TBC
Depth (mm)	745	554	TBC
Height (mm)	2210	1570	TBC
Weight (kg)	(castors) TBC		TBC
Capacity (L)	1396		
Footprint (m²)	1.27		

Ventilation (mm)

Top	Sides	Rear
300	Not required	10

Dimensional Tolerances

† Allow for dimensional tolerances when installing the cabinet(s).

Linear dimensions At each joint	Single cabinet		Multiple cabinets At each end wall
	Less than 1 metre	±5 mm ±5 mm	
Less than 1 metre	±5 mm ±5 mm	+15 mm	
More than 1 metre	-5 mm to +10 mm	-5 mm to +10 mm	+15 mm

Performance

Product Temperature Range (°C)	-18 to -21 (adjustable* from -12 to
Maximum Ambient Temperature (°C)	-26) 40
Sound Level (dB(A))	Standard 67 Hush Mode * 65

Greenhouse and Energy Minimum Standards (GEMS)

Star Rating	2
Product Temperature Class	L1 (less than -18°C)
Total Energy Consumption	31.35 kWh/24 h
Annual Running Costs	\$3433 (@ \$0.30/kWh)

Electrical

Supply	220-240 volts a.c., 50 Hz, single phase supply
Cord	2.3 m power cord with 3-pin, 15 amp plug
Current draw (A)	11.5

Refrigeration

Controller	SCS Connect (SKOPE-connect™ compatible)
System Type	Removable cartridge
Cartridge Weight (kg)	47.5 x 2
Refrigerant/Charge	R290/112 x 2 g
Nominal Capacity (W)	1504 (2 x 752)
Heat Rejection (W)	Average 1305 Peak 1540 Hot gas
Defrost Type	No plumbing required
Drainage	

* Accessible via the free SKOPE-connect™ app.



TMF1500N-AC
on the SKOPE website