

FF5E Series

Freon Flake Ice Making Systems



FF5E

FF-E Series (Freon Flake Evaporator, no refrigeration included)

Also available in 400kg, 600kg, 1 Ton, 1.5 Ton, 2 Ton, 2.5 Ton, 3.2 Ton, 10 Ton, 15 Ton, 20 Ton, 30 Ton, 40 Ton and 50 Ton.

The FFE Series is suited to those contractors that may wish to combine a single, or multiple evaporators together, operating on a common refrigeration plant.

The FFE Series comes complete with control system, water pump, and gear motor assembly. This offers a choice for the Customer to use their preferred refrigeration equipment.

Warranty: 3 years parts and labour, 5 years on evaporator assembly.

ACCESSORIES

WATER FILTERS	
SYSTEM	REPLACEMENT
CD40B	CD2020B CD250B

ICE PRODUCTION

Model Number	Ice Production Per 24hrs
FF5E	5T



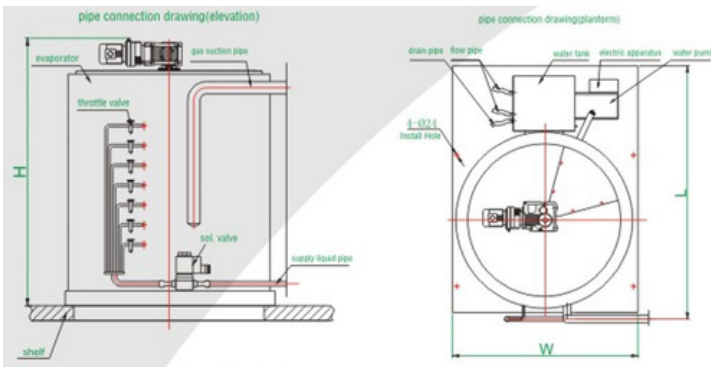

DIMENSIONS WITHOUT PACKING

Model	Ice Machine Dimensions W	Ice Machine Dimensions D	Ice Machine Dimensions H
FF5E	1850 mm	1150 mm	1250 mm

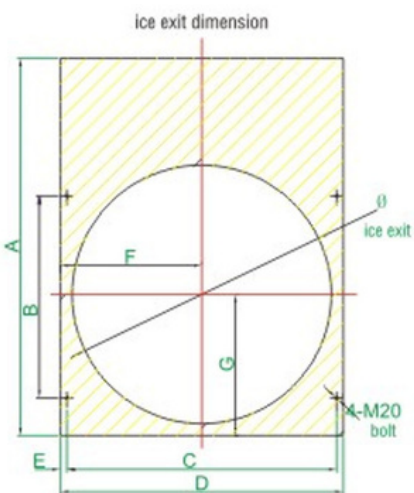

ICE OUTLET DIMENSIONS

Model	A	B	C	D	E	F	G	Ice Outlet Internal Dia.
FF5E	1850 mm	1050 ± 1 mm	1000 ± 1 mm	1150 mm	50 mm	575 mm	875 mm	∅ 900

TECHNICAL PARAMETER

Model	Refrigerating Capacity	Gear Motor Power	Water Pump Power	Water Consumption	Inlet Water Connection	Drainpipe External Diameter	Net Weight (kg)
FF5E	28 kW	370W	65W	208 L/hr	3/4" GAS	∅ 21 mm	1200 kg

Notes:

- Refrigerant Type: R22/R404A
- Standard Conditions: Ambient Air Temperature 25°C, Water Temperature 16°C • Condensing Temperature 40°C
- Evaporating Temperature -22°C
- Electrical Voltage: 380V/50Hz / 3N
- Supply Water Pressure: 1.5 BAR - 5 BAR

