

IRENE ECO 250 | Irene ECO 2505mm Island Freezer

Island Freezers

IRENE ECO 250

IRENE ECO 2505MM ISLAND FREEZER

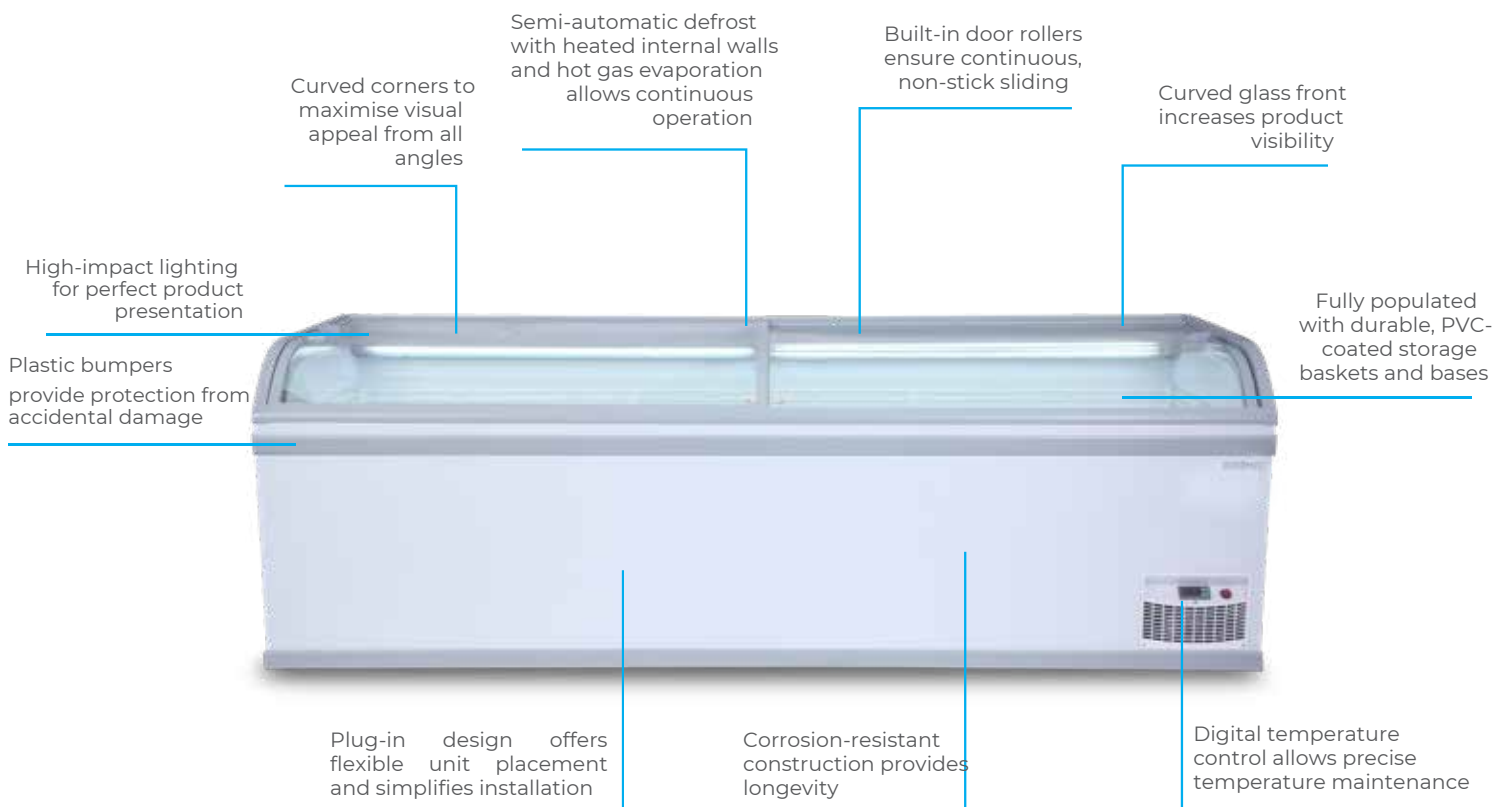

IRENE ECO 250 | Irene ECO 2505mm Island Freezer

Island Freezers

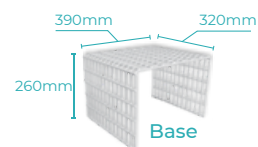
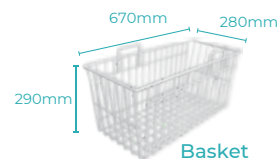
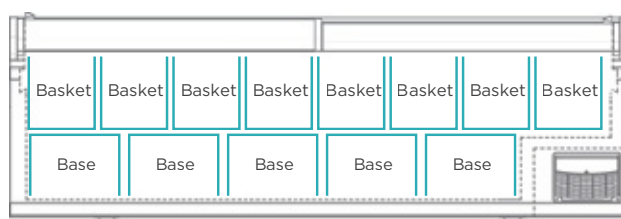
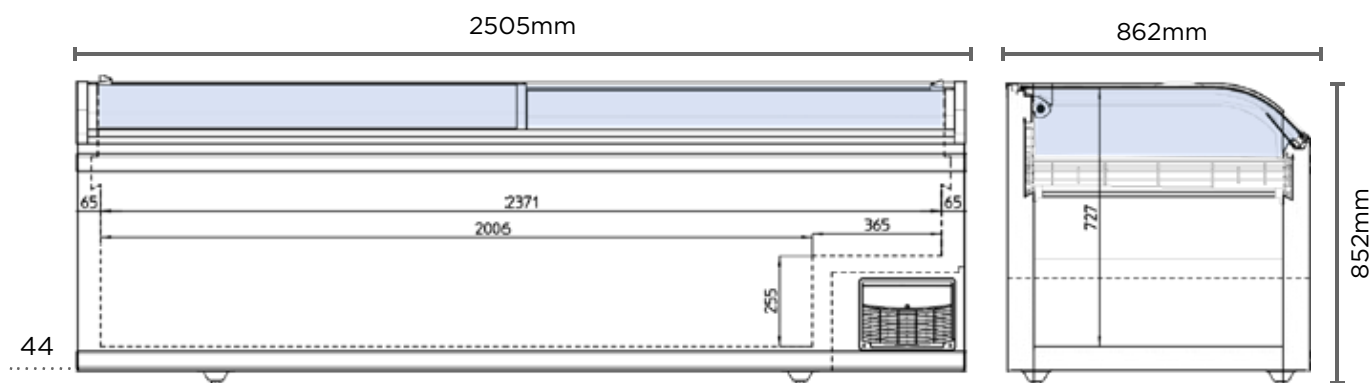

SPECIFICATIONS

Model	IRENE ECO 250	No. of Lids	2
Part Number	3735317	Lid Type	Slide
Capacity	1155/815L	Lid Shape	Curved
Temp. Range (°C)	-25 to -18°C	Glazed Safety Glass	Yes
Max. Ambient Temp. (°C)	25°C Class 5	Digital Temp. Controller	Yes
Refrigeration Capacity	740W	Feet	Yes
Energy Consumption	7.7kWh/24h	No. of Baskets Incl.	8
Current	3.5A	No. of Bases Incl.	5
Gross Weight	202kg	Defrost System	Semi-Automatic
Packaged Dimensions	1010 x 2625 x 980 mm	Colour	White
Refrigerant	R290	Warranty	1 Year, Parts &
Plug Supplied	Yes, 2 x 10A	Warranty Service	Labour Bromic Extra
Plug Location	Underneath cabinet		Care
Total Display Area	1.7m ³		
Main Light	Fluorescent		

DIMENSIONS

	External (mm)
Height	852
Width	2505
Depth	862
	Internal (mm)
Height	753
Width	2371
Depth	702