

## IRENE ECO 185 | Irene ECO 1856mm Island Freezer End Cabinet

Island Freezers

### IRENE ECO 185

### IRENE ECO 1856MM ISLAND FREEZER END CABINET

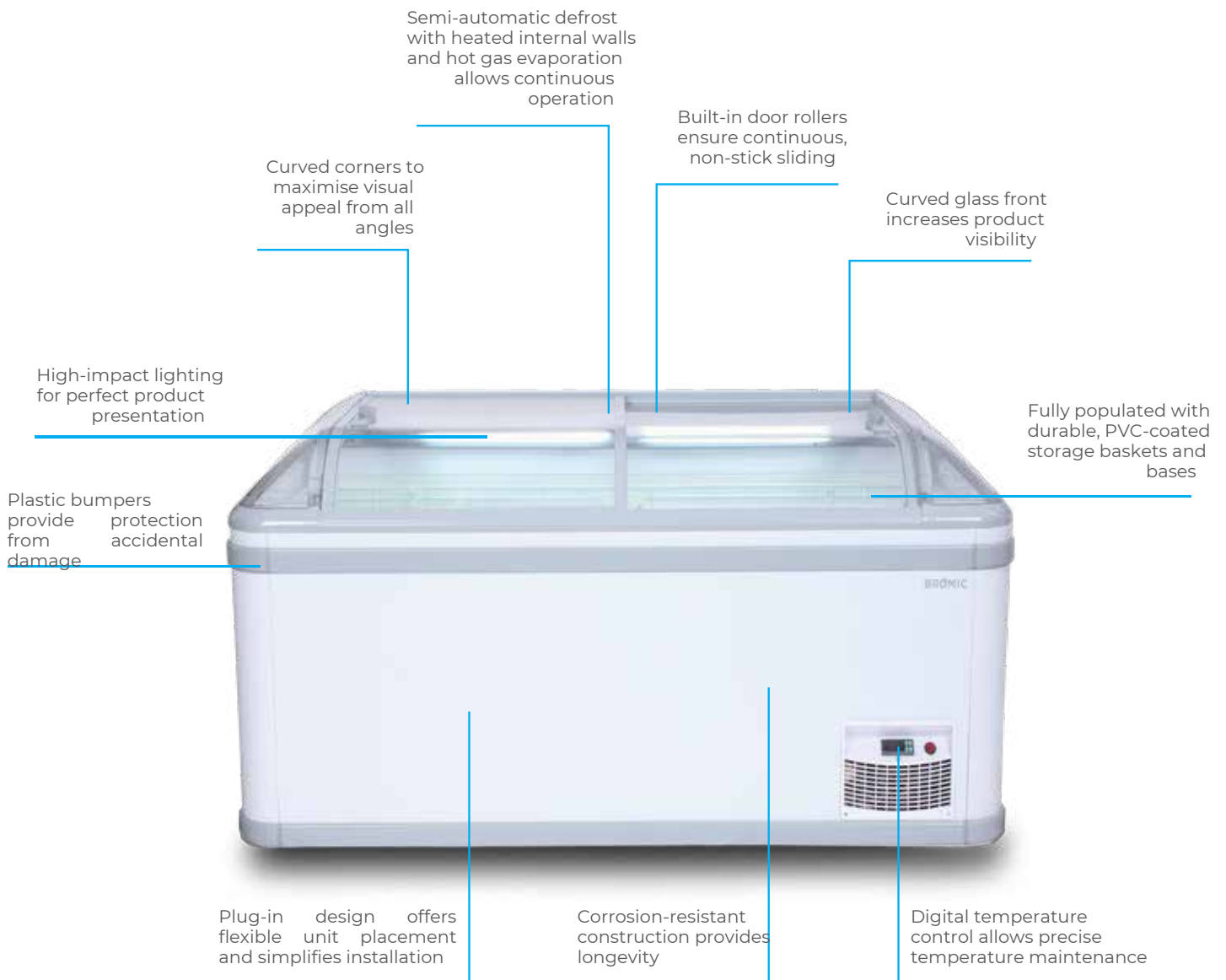

## IRENE ECO 185 | Irene ECO 1856mm Island Freezer End Cabinet

Island Freezers

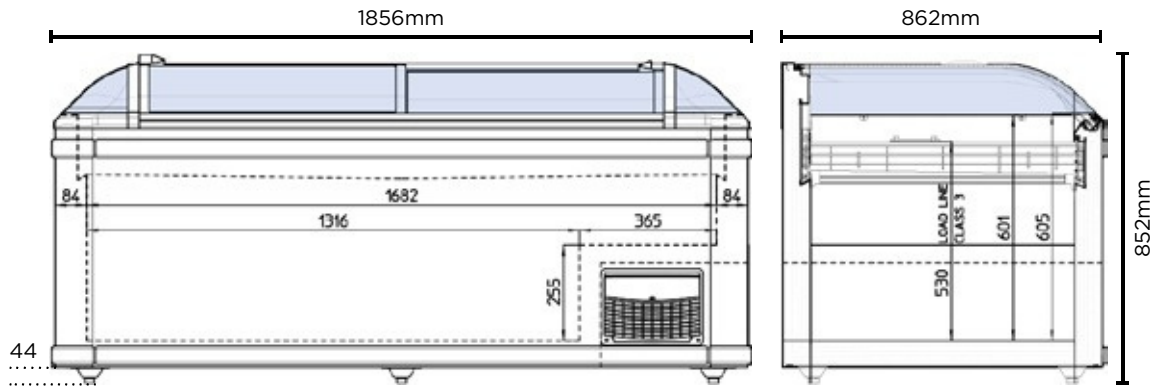

### Base & Basket Layout

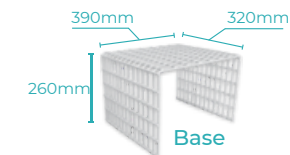
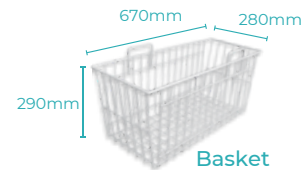
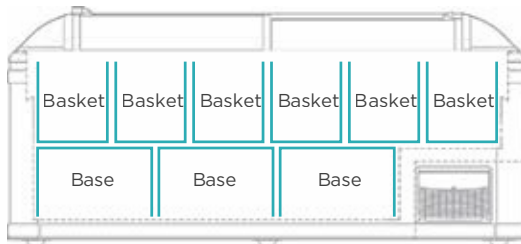

### SPECIFICATIONS

Model	IRENE ECO 185	No. of Lids	2
Part Number	3735319	Lid Type	Slide
Capacity	805/525L	Lid Shape	Curved
Temp. Range (°C)	-25 to -18°C	Glazed Safety Glass	Yes
Max. Ambient Temp. (°C)	25°C Class 3	Digital Temp. Controller	Yes
Refrigeration Capacity	780W	Feet	Yes
Energy Consumption	6.9kWh/24h	No. of Baskets Incl.	6
Current	3.5A	No. of Bases Incl.	3
Gross Weight	161kg	Defrost System	Semi-Automatic
Packaged Dimensions	1010 x 1985 x 980 mm	Colour	White
Refrigerant	R290	Warranty	1 Year, Parts &
Plug Supplied	Yes, 2 x 10A	Warranty Service	Labour Bromic Extra
Plug Location	Underneath cabinet		Care
Total Display Area	1.3m <sup>2</sup>		
Main Light	Fluorescent		

### DIMENSIONS

	External (mm)
Heig	852
ht	1856
Widt	862
h	
Dept	Internal (mm)
h	753
ht	1682
Widt	702
h	
Dept	
h	