

FD4TI500C | 4 Tier Cold Food Display 1500mm

Food Displays

FD4TI500C

4 TIER COLD
FOOD DISPLAY
1500MM



FD4TI500C | 4 Tier Cold Food Display 1500mm

Food Displays

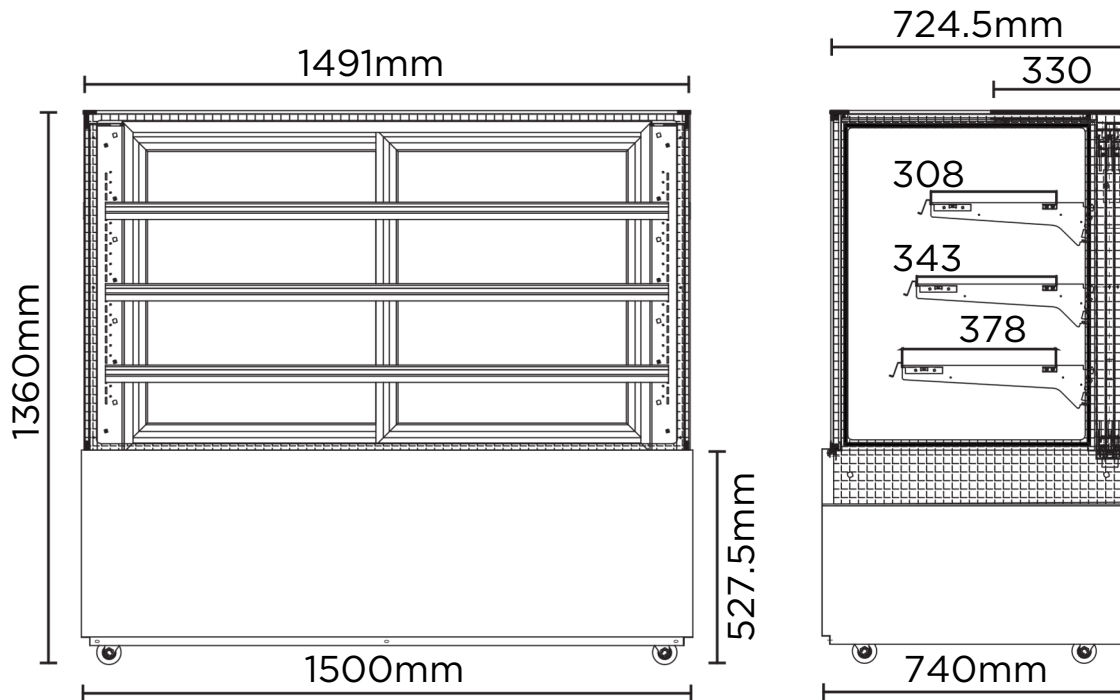

SPECIFICATIONS	Part Number	3736310
	Capacity	686L
	Temp. Range	+2 to +6°C
	Max. Ambient Temp.	32°C
	Refrigeration Power	1220W
	Energy Consumption	19.159kWh/24h
	Gross Weight	319kg
	Packaged Dimensions	1600 x 850 x 1510 mm
	Refrigerant	R404a
	Plug Supplied	Yes, 1 x 10A
	Plug Location	Rear, Right Hand Side
	Main Light	LED
	Number of Doors	2
	Door Type	Sliding
	Temp. Controller	Digital
	Castors	Yes
	No. of Shelves inc. Base	4
	Shelves Dimensions	1417(w) x 307(d), 1417(w) x 342(d), 1417(w) x 377(d) mm
Colour	Stainless Steel	
Warranty	1 Year Parts & Labour	
Warranty Service	Bromic Extra Care	

DIMENSIONS	External (mm)	
	Width	1500
	Depth	740
	Height	1360
	Internal (mm)	
	Width	1474
Depth	647	
Height	828	