

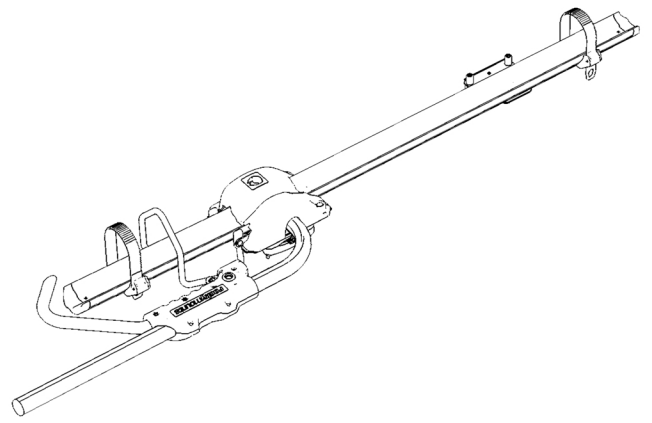

# rockymounts TomaHawk



## Guidelines

- Minimum crossbar spread: 24" (61 cm), Maximum crossbar spread: 37" (94cm)
- Bicycle weight limit: 40 lbs. (18 kg)
- 2 bicycle maximum on factory crossbars
- 20" - 29" wheels only. Fits up to 5" tires
- Remove front fenders, front racks, and panniers before use
- Install as roof rack only
- No electric bikes, kick bikes, recumbents, mopeds, scooters, pannifarthings, tandems, or bikes with 48" (122cm), wheelbase or greater.
- Not for use on trailers or towed vehicles

## Parts Included

A: Load Arm Assembly  
 B: Rear Tray  
 C: Rear mounting plate  
 D: Front mounting bracket

E: End Cap  
 F: Back Stop  
 G: Wheel Strap  
 H: Wheel Strap Extension

I: 5mm Hex Key  
 J: 4mm Hex Key  
 K: M5x10 Bolt

Note: Rack is configured for installation on the driver's side. For passenger side installation, you will need to remove the arm assembly and reverse, follow steps at "Passenger Side Configuration".

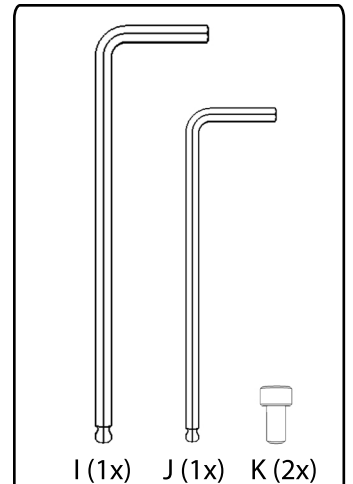
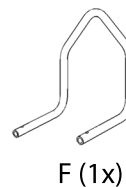
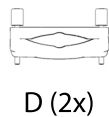
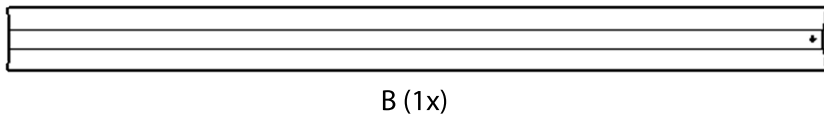
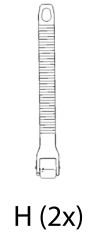
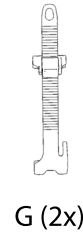
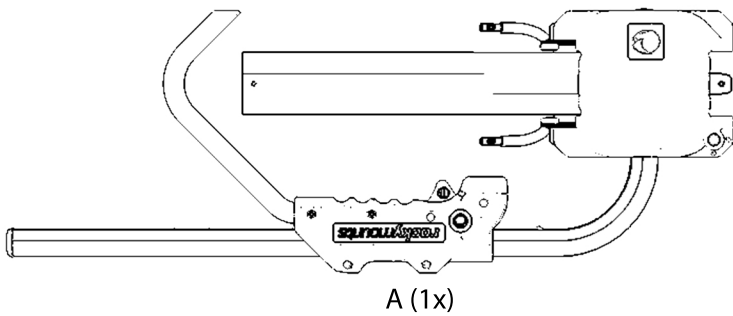

\*Locks Not Included

## Assembly Instructions

### 1 Install Rear Tray

Push on two tabs and remove cover. Slide rear tray onto load arm assembly. Tighten four M6 bolts

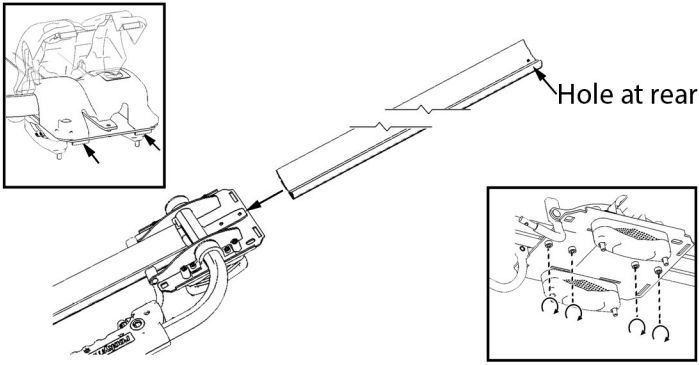

### 2 Open Mounting Brackets

Remove four M6x65 bolts on front mounting brackets. Slide rear mounting plate into T-slot with brackets facing towards vehicle. Loosen two M6x55 bolts

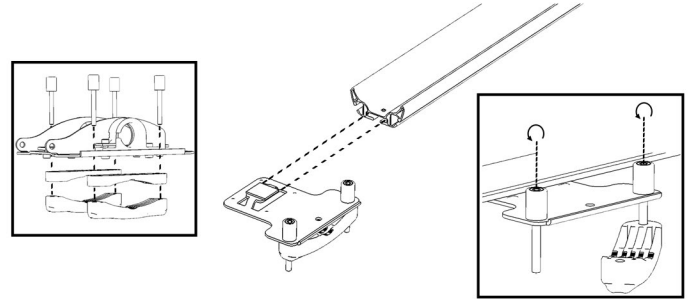

### 3 Tighten Mounting Brackets

Place head onto front crossbar. Slide rear mounting plate above rear crossbar. Tighten six bolts on brackets

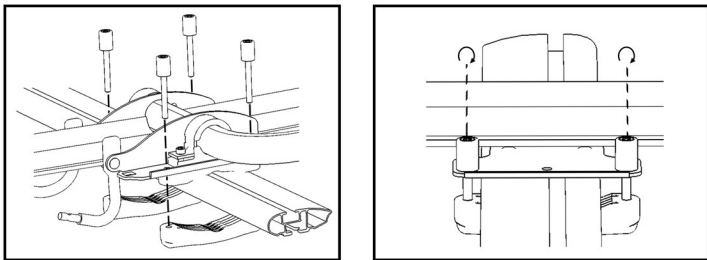

### 4 Install Wheel Straps

Slide wheel straps onto wheel tray with buckles facing out. Install end caps

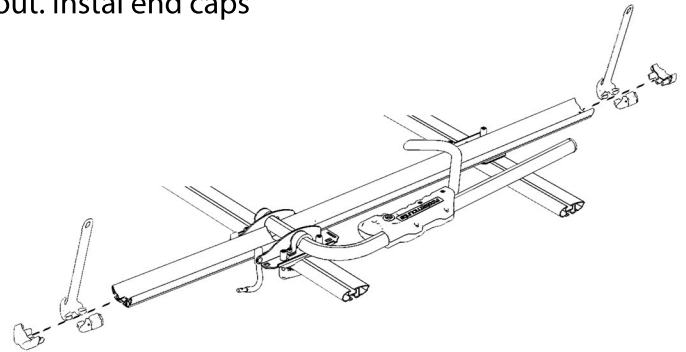

**Start here: Loading Bikes**

### 5 Install Back Stop

Install cover. Install back stop and tighten two M5x10 bolts

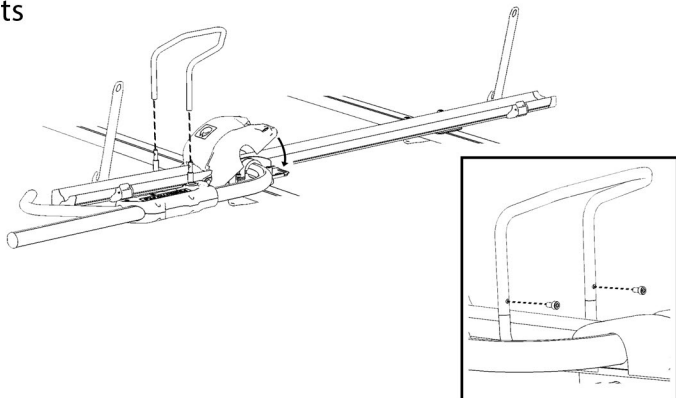

### 1 Loading Preparation

Fully extend load arm hook. Fully open back stop. Loop wheel straps back and catch on plastic tabs

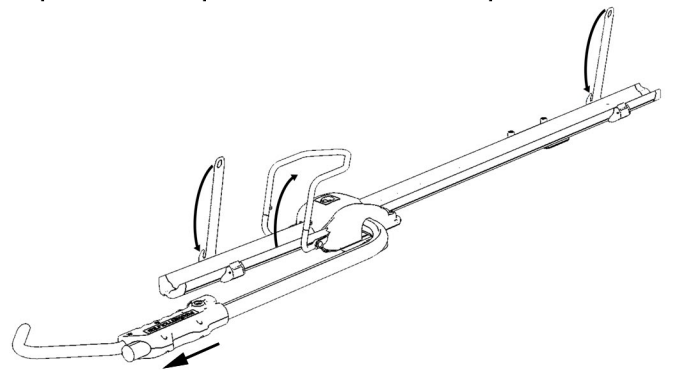

## Loading Bikes

### 2 Place Bike on Rack

Load bike on wheel tray. **FRONT WHEEL SHOULD BE SECURE AGAINST BACK STOP**

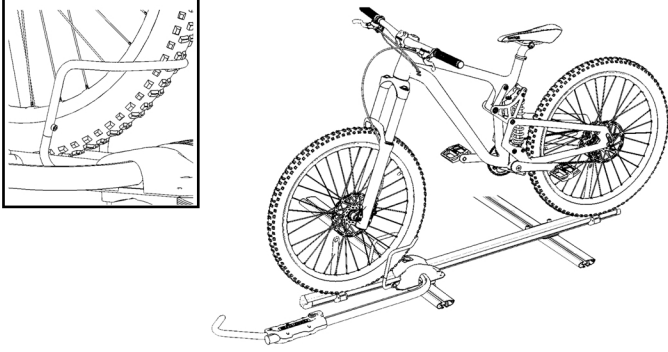

### 3 Secure Front Wheel

Rotate load arm over front wheel and tighten hook with **MINIMUM GAP** between fork

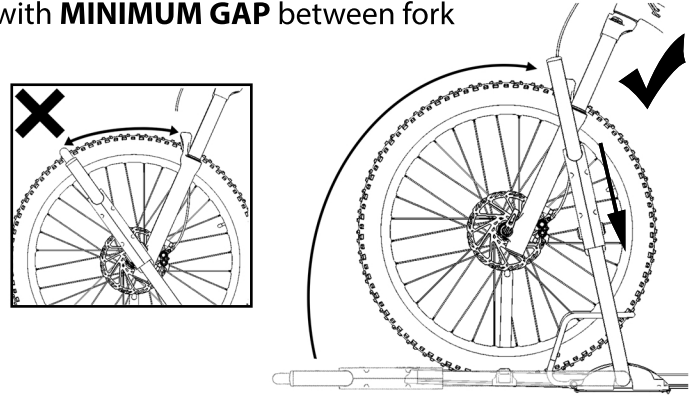

### 4 Tighten Wheel Straps

For both wheels: feed wheel strap through wheel and into buckle. Test bike by shaking

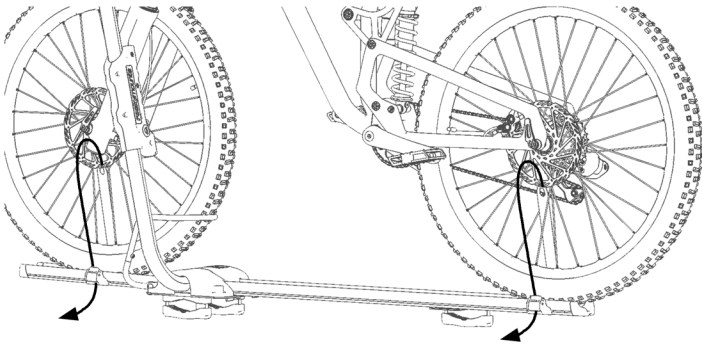

### 5 Fat Bike Installation

To mount fat bikes, add an extension to each wheel strap. For both wheels: feed wheel strap through wheel and into buckle. Test bike by shaking

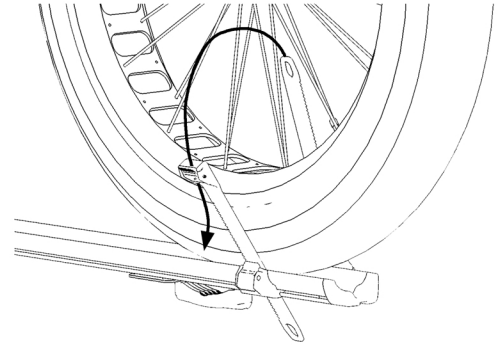

## Start Here: Lock Core Installation Instructions

### 1 Pry Off Lock Cap

Pry off plastic cap on cover using a screwdriver

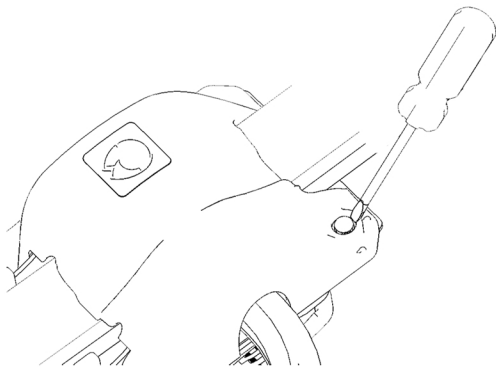

### 2 Install Lock Core

Insert key into core and line up large protruding metal wafer between tabs in housing. Install lock cores, turn key to "lock" position and pull key out

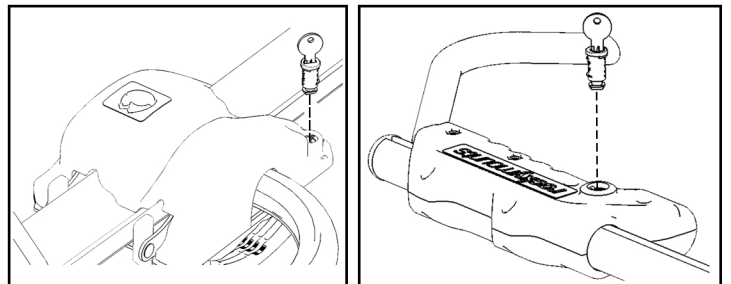

## Passenger Side Installation Instructions

### 1 Remove End Cap

Remove cover on load arm assembly. Remove M6x15 bolt and plastic stopper. Remove end cap on load arm

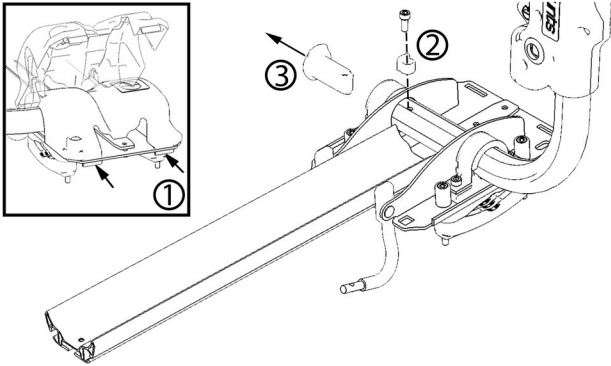

### 2 Remove Load Arm

Loosen four M6 bolts on bearings and slide load arm out

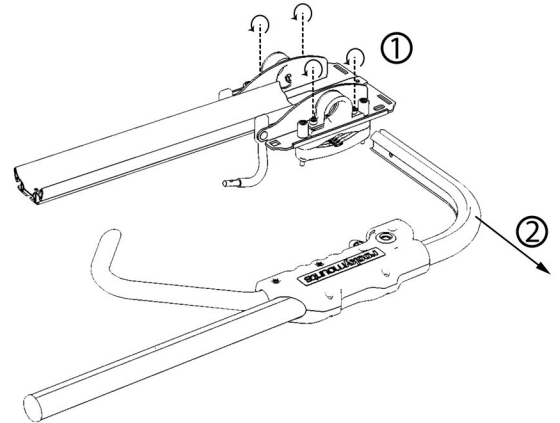

### 3 Flip Load Arm

Flip load arm and reinstall from the other direction. Install M8x15 bolt with plastic stopper

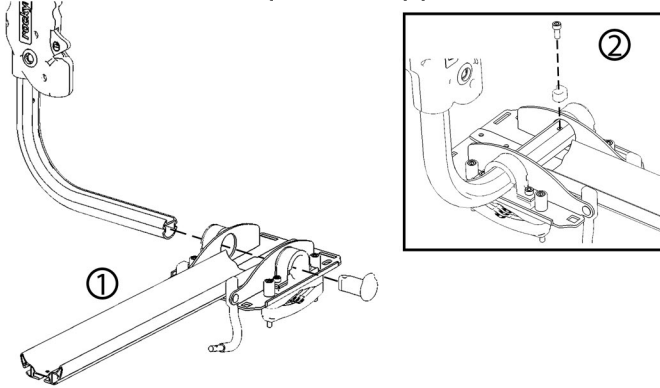

### 4 Mounting

Tighten four M6 bolts

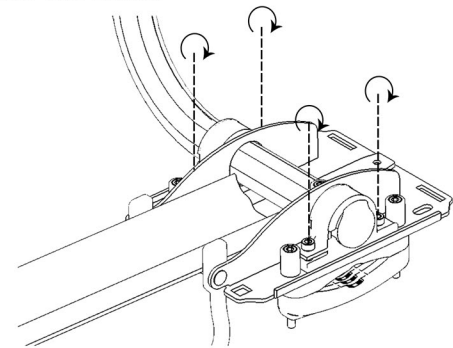

Follow Step 1 to Step 5 on Page 1 to mount rack onto vehicle

## Warnings

- Remove Baby Seats, Panniers, U-Locks, or items that could detach from the bicycle.
- Do not use bicycle covers, bicycle bras, or bikes equipped with rear disc wheel.
- Not intended for off road use. Not intended for use on trailers or towed vehicles.
- Locks are only deterrents to thieves, RockyMounts, Inc. cannot be held liable for stolen bicycles.
- Remove rack before entering a car wash.
- Check all fastenings (nuts, bolts, straps, and skewer) before each use.
- Once a year, remove rack from car. Clean and inspect for damage.
- Do not mount vertically

## Lifetime Warranty

Thank you for purchasing a RockyMounts product. We take pride in providing a great customer experience and manufacturing products that enable our customers to get their gear to their next colorful adventure.

As of January 1, 2014, RockyMounts products are covered for life to the original purchaser when used in accordance with the instruction manuals' assembly, installation and use guidelines.

If you feel something broke before it's time; please email us at [ride@rockymounts.com](mailto:ride@rockymounts.com) or call us at 800.873.1871. For the most efficient service, email a digital photo (we need this photo to verify the problem) of the product in questions, a brief description of the situation, and your purchase receipt. Our techs will respond within one business day. Most of the time we'll replace the part in question, but we may ask for more details.

RockyMounts, Inc. warranty only covers RockyMounts, Inc. products. It does not cover theft, or damage to vehicles and/or equipment. All products purchased prior to Jan 1, 2014 are covered by a one-year warranty; see your product manual for details.